

Quick page links

[title](#) [tableofcontents](#)

[L01_01](#) [L01_02](#) [L01_03](#) [L01_04](#) [L01_05](#) [L01_06](#) [L01_07](#) [L01_08](#) [L01_09](#) [L01_10](#)
[L01_11](#) [L01_12](#) [L01_13](#) [L01_14](#) [L01_15](#) [L01_16](#)

[L02_01](#) [L02_02](#) [L02_03](#) [L02_04](#) [L02_05](#) [L02_06](#) [L02_07](#) [L02_08](#) [L02_09](#) [L02_10](#)
[L02_11](#) [L02_12](#) [L02_13](#) [L02_14](#) [L02_15](#) [L02_16](#) [L02_17](#)

[L03_01](#) [L03_02](#) [L03_03](#) [L03_04](#) [L03_05](#) [L03_06](#) [L03_07](#) [L03_08](#) [L03_09](#) [L03_10](#)
[L03_11](#) [L03_12](#) [L03_13](#) [L03_14](#)

[L04_01](#) [L04_02](#) [L04_03](#) [L04_04](#) [L04_05](#) [L04_06](#) [L04_07](#) [L04_08](#) [L04_09](#) [L04_10](#)
[L04_11](#) [L04_12](#) [L04_13](#) [L04_14](#) [L04_15](#) [L04_16](#) [L04_17](#)

[L05_01](#) [L05_02](#) [L05_03](#) [L05_04](#) [L05_05](#) [L05_06](#) [L05_07](#) [L05_08](#) [L05_09](#) [L05_10](#)
[L05_11](#) [L05_12](#) [L05_13](#) [L05_14](#) [L05_15](#) [L05_16](#)

[L06_01](#) [L06_02](#) [L06_03](#) [L06_04](#) [L06_05](#) [L06_06](#) [L06_07](#) [L06_08](#) [L06_09](#) [L06_10](#)
[L06_11](#) [L06_12](#) [L06_13](#) [L06_14](#)

[L07_01](#) [L07_02](#) [L07_03](#) [L07_04](#) [L07_05](#) [L07_06](#) [L07_07](#) [L07_08](#) [L07_09](#) [L07_10](#)
[L07_11](#) [L07_12](#) [L07_13](#) [L07_14](#) [L07_15](#) [L07_16](#) [L07_17](#) [L07_18](#) [L07_19](#) [L07_20](#)
[L07_21](#) [L07_22](#)

[L08_01](#) [L08_02](#) [L08_03](#) [L08_04](#) [L08_05](#) [L08_06](#) [L08_07](#) [L08_08](#) [L08_09](#) [L08_10](#)
[L08_11](#) [L08_12](#) [L08_13](#) [L08_14](#) [L08_15](#) [L08_16](#) [L08_17](#) [L08_18](#)

[L09_01](#) [L09_02](#) [L09_03](#) [L09_04](#) [L09_05](#) [L09_06](#) [L09_07](#) [L09_08](#) [L09_09](#) [L09_10](#)
[L09_11](#) [L09_12](#) [L09_13](#) [L09_14](#)

[L10_01](#) [L10_02](#) [L10_03](#) [L10_04](#) [L10_05](#) [L10_06](#) [L10_07](#) [L10_08](#) [L10_09](#) [L10_10](#)
[L10_11](#) [L10_12](#)

[L11_01](#) [L11_02](#) [L11_03](#) [L11_04](#) [L11_05](#) [L11_06](#) [L11_07](#) [L11_08](#) [L11_09](#) [L11_10](#)
[L11_11](#) [L11_12](#) [L11_13](#) [L11_14](#) [L11_15](#) [L11_16](#) [L11_17](#)

[L12_01](#) [L12_02](#) [L12_03](#) [L12_04](#) [L12_05](#) [L12_06](#) [L12_07](#) [L12_08](#) [L12_09](#) [L12_10](#)
[L12_11](#) [L12_12](#) [L12_13](#) [L12_14](#) [L12_15](#) [L12_16](#) [L12_17](#) [L12_18](#) [L12_19](#) [L12_20](#)
[L12_21](#) [L12_22](#) [L12_23](#)

[L13_01](#) [L13_02](#) [L13_03](#) [L13_04](#) [L13_05](#) [L13_06](#) [L13_07](#) [L13_08](#) [L13_09](#) [L13_10](#)
[L13_11](#) [L13_12](#) [L13_13](#) [L13_14](#) [L13_15](#) [L13_16](#) [L13_17](#)

[L14_01](#) [L14_02](#) [L14_03](#) [L14_04](#) [L14_05](#) [L14_06](#) [L14_07](#) [L14_08](#) [L14_09](#) [L14_10](#)
[L14_11](#) [L14_12](#) [L14_13](#) [L14_14](#) [L14_15](#) [L14_16](#) [L14_17](#) [L14_18](#) [L14_19](#) [L14_20](#)

[L15_01](#) [L15_02](#) [L15_03](#) [L15_04](#) [L15_05](#) [L15_06](#) [L15_07](#) [L15_08](#) [L15_09](#) [L15_10](#)
[L15_11](#) [L15_12](#) [L15_13](#) [L15_14](#) [L15_15](#) [L15_16](#) [L15_17](#) [L15_18](#) [L15_19](#)

[L16_01](#) [L16_02](#) [L16_03](#) [L16_04](#) [L16_05](#) [L16_06](#) [L16_07](#) [L16_08](#) [L16_09](#) [L16_10](#)
[L16_11](#)

[L17_01](#) [L17_02](#) [L17_03](#) [L17_04](#) [L17_05](#) [L17_06](#) [L17_07](#) [L17_08](#) [L17_09](#)

[L18_01](#) [L18_02](#) [L18_03](#) [L18_04](#) [L18_05](#) [L18_06](#) [L18_07](#) [L18_08](#) [L18_09](#) [L18_10](#)
[L18_11](#) [L18_12](#) [L18_13](#) [L18_14](#)

[L19_01](#) [L19_02](#) [L19_03](#) [L19_04](#) [L19_05](#) [L19_06](#) [L19_07](#) [L19_08](#) [L19_09](#) [L19_10](#)
[L19_11](#) [L19_12](#) [L19_13](#) [L19_14](#) [L19_15](#)

[L20_01](#) [L20_02](#) [L20_03](#) [L20_04](#) [L20_05](#) [L20_06](#) [L20_07](#) [L20_08](#) [L20_09](#) [L20_10](#)

[L20_11](#) [L20_12](#)

[L21_01](#) [L21_02](#) [L21_03](#) [L21_04](#) [L21_05](#) [L21_06](#) [L21_07](#) [L21_08](#) [L21_09](#) [L21_10](#)
[L21_11](#) [L21_12](#) [L21_13](#) [L21_14](#)

[L22_01](#) [L22_02](#) [L22_03](#) [L22_04](#) [L22_05](#) [L22_06](#) [L22_07](#) [L22_08](#) [L22_09](#) [L22_10](#)
[L22_11](#) [L22_12](#) [L22_13](#) [L22_14](#) [L22_15](#) [L22_16](#) [L22_17](#)

[L23_01](#) [L23_02](#) [L23_03](#) [L23_04](#) [L23_05](#) [L23_06](#) [L23_07](#) [L23_08](#) [L23_09](#) [L23_10](#)
[L23_11](#) [L23_12](#) [L23_13](#) [L23_14](#) [L23_15](#) [L23_16](#) [L23_17](#) [L23_18](#) [L23_19](#) [L23_20](#)
[L23_21](#)

[L24_01](#) [L24_02](#) [L24_03](#) [L24_04](#) [L24_05](#) [L24_06](#) [L24_07](#) [L24_08](#) [L24_09](#) [L24_10](#)
[L24_11](#) [L24_12](#) [L24_13](#) [L24_14](#) [L24_15](#) [L24_16](#) [L24_17](#) [L24_18](#)

[L25_01](#) [L25_02](#) [L25_03](#) [L25_04](#) [L25_05](#) [L25_06](#) [L25_07](#) [L25_08](#) [L25_09](#) [L25_10](#)
[L25_11](#) [L25_12](#) [L25_13](#) [L25_14](#) [L25_15](#) [L25_16](#)

[L26_01](#) [L26_02](#) [L26_03](#) [L26_04](#) [L26_05](#) [L26_06](#) [L26_07](#) [L26_08](#) [L26_09](#) [L26_10](#)
[L26_11](#) [L26_12](#) [L26_13](#) [L26_14](#) [L26_15](#) [L26_16](#) [L26_17](#)

[L27_01](#) [L27_02](#) [L27_03](#) [L27_04](#) [L27_05](#) [L27_06](#) [L27_07](#) [L27_08](#) [L27_09](#) [L27_10](#)
[L27_11](#) [L27_12](#) [L27_13](#) [L27_14](#) [L27_15](#) [L27_16](#) [L27_17](#) [L27_18](#) [L27_19](#) [L27_20](#)
[L27_21](#) [L27_22](#) [L27_23](#) [L27_24](#) [L27_25](#) [L27_26](#) [L27_27](#) [L27_28](#) [L27_29](#) [L27_30](#)

[L28_01](#) [L28_02](#) [L28_03](#) [L28_04](#) [L28_05](#) [L28_06](#) [L28_07](#) [L28_08](#) [L28_09](#) [L28_10](#)
[L28_11](#) [L28_12](#) [L28_13](#) [L28_14](#) [L28_15](#) [L28_16](#) [L28_17](#) [L28_18](#) [L28_19](#) [L28_20](#)

[L29_01](#) [L29_02](#) [L29_03](#) [L29_04](#) [L29_05](#) [L29_06](#) [L29_07](#) [L29_08](#) [L29_09](#) [L29_10](#)
[L29_11](#) [L29_12](#) [L29_13](#) [L29_14](#) [L29_15](#) [L29_16](#) [L29_17](#) [L29_18](#) [L29_19](#) [L29_20](#)
[L29_21](#) [L29_22](#) [L29_23](#) [L29_24](#) [L29_25](#)

[L30_01](#) [L30_02](#) [L30_03](#) [L30_04](#) [L30_05](#) [L30_06](#) [L30_07](#) [L30_08](#) [L30_09](#) [L30_10](#)
[L30_11](#) [L30_12](#) [L30_13](#) [L30_14](#) [L30_15](#) [L30_16](#) [L30_17](#) [L30_18](#) [L30_19](#) [L30_20](#)
[L30_21](#) [L30_22](#) [L30_23](#) [L30_24](#) [L30_25](#) [L30_26](#) [L30_27](#) [L30_28](#) [L30_29](#) [L30_30](#)
[L30_31](#) [L30_32](#) [L30_33](#) [L30_34](#) [L30_35](#)

[L31_01](#) [L31_02](#) [L31_03](#) [L31_04](#) [L31_05](#) [L31_06](#) [L31_07](#) [L31_08](#) [L31_09](#) [L31_10](#)
[L31_11](#) [L31_12](#) [L31_13](#) [L31_14](#) [L31_15](#) [L31_16](#) [L31_17](#) [L31_18](#) [L31_19](#) [L31_20](#)
[L31_21](#) [L31_22](#) [L31_23](#) [L31_24](#)

[L32_01](#) [L32_02](#) [L32_03](#) [L32_04](#) [L32_05](#) [L32_06](#) [L32_07](#) [L32_08](#) [L32_09](#) [L32_10](#)
[L32_11](#) [L32_12](#) [L32_13](#) [L32_14](#) [L32_15](#) [L32_16](#) [L32_17](#) [L32_18](#) [L32_19](#) [L32_20](#)
[L32_21](#) [L32_22](#) [L32_23](#) [L32_24](#) [L32_25](#) [L32_26](#) [L32_27](#) [L32_28](#) [L32_29](#) [L32_30](#)
[L32_31](#) [L32_32](#) [L32_33](#)

[L33_01](#) [L33_02](#) [L33_03](#) [L33_04](#) [L33_05](#) [L33_06](#) [L33_07](#) [L33_08](#) [L33_09](#) [L33_10](#)
[L33_11](#) [L33_12](#) [L33_13](#) [L33_14](#) [L33_15](#) [L33_16](#) [L33_17](#) [L33_18](#) [L33_19](#) [L33_20](#)
[L33_21](#) [L33_22](#) [L33_23](#)

[L34_01](#) [L34_02](#) [L34_03](#) [L34_04](#) [L34_05](#) [L34_06](#) [L34_07](#) [L34_08](#) [L34_09](#) [L34_10](#)
[L34_11](#) [L34_12](#) [L34_13](#) [L34_14](#) [L34_15](#) [L34_16](#) [L34_17](#) [L34_18](#) [L34_19](#) [L34_20](#)
[L34_21](#) [L34_22](#)

[L35_01](#) [L35_02](#) [L35_03](#) [L35_04](#) [L35_05](#) [L35_06](#) [L35_07](#) [L35_08](#) [L35_09](#) [L35_10](#)
[L35_11](#) [L35_12](#) [L35_13](#) [L35_14](#) [L35_15](#) [L35_16](#) [L35_17](#) [L35_18](#) [L35_19](#) [L35_20](#)
[L35_21](#) [L35_22](#) [L35_23](#) [L35_24](#)

[L36_01](#) [L36_02](#) [L36_03](#) [L36_04](#) [L36_05](#) [L36_06](#) [L36_07](#) [L36_08](#) [L36_09](#) [L36_10](#)
[L36_11](#) [L36_12](#) [L36_13](#) [L36_14](#) [L36_15](#) [L36_16](#) [L36_17](#) [L36_18](#) [L36_19](#) [L36_20](#)
[L36_21](#) [L36_22](#) [L36_23](#) [L36_24](#) [L36_25](#) [L36_26](#) [L36_27](#) [L36_28](#) [L36_29](#) [L36_30](#)

[L37_01](#) [L37_02](#) [L37_03](#) [L37_04](#) [L37_05](#) [L37_06](#) [L37_07](#) [L37_08](#) [L37_09](#) [L37_10](#)
[L37_11](#) [L37_12](#) [L37_13](#) [L37_14](#) [L37_15](#) [L37_16](#) [L37_17](#) [L37_18](#) [L37_19](#) [L37_20](#)
[L37_21](#) [L37_22](#) [L37_23](#) [L37_24](#)

[L38_01](#) [L38_02](#) [L38_03](#) [L38_04](#) [L38_05](#) [L38_06](#) [L38_07](#) [L38_08](#) [L38_09](#) [L38_10](#)
[L38_11](#) [L38_12](#) [L38_13](#) [L38_14](#) [L38_15](#) [L38_16](#) [L38_17](#) [L38_18](#) [L38_19](#)

[L39_01](#) [L39_02](#) [L39_03](#) [L39_04](#) [L39_05](#) [L39_06](#) [L39_07](#) [L39_08](#) [L39_09](#) [L39_10](#)
[L39_11](#) [L39_12](#) [L39_13](#) [L39_14](#) [L39_15](#) [L39_16](#) [L39_17](#) [L39_18](#) [L39_19](#) [L39_20](#)
[L39_21](#) [L39_22](#) [L39_23](#) [L39_24](#) [L39_25](#) [L39_26](#) [L39_27](#)

[L40_01](#) [L40_02](#) [L40_03](#) [L40_04](#) [L40_05](#) [L40_06](#) [L40_07](#) [L40_08](#) [L40_09](#) [L40_10](#)
[L40_11](#) [L40_12](#) [L40_13](#) [L40_14](#) [L40_15](#) [L40_16](#) [L40_17](#) [L40_18](#) [L40_19](#) [L40_20](#)
[L40_21](#) [L40_22](#) [L40_23](#) [L40_24](#) [L40_25](#) [L40_26](#) [L40_27](#) [L40_28](#) [L40_29](#) [L40_30](#)
[L40_31](#) [L40_32](#)

[L41_01](#) [L41_02](#) [L41_03](#) [L41_04](#) [L41_05](#) [L41_06](#) [L41_07](#) [L41_08](#) [L41_09](#) [L41_10](#)
[L41_11](#) [L41_12](#) [L41_13](#) [L41_14](#) [L41_15](#) [L41_16](#) [L41_17](#) [L41_18](#) [L41_19](#) [L41_20](#)
[L41_21](#) [L41_22](#) [L41_23](#) [L41_24](#) [L41_25](#)

[L42_01](#) [L42_02](#) [L42_03](#) [L42_04](#) [L42_05](#) [L42_06](#) [L42_07](#) [L42_08](#) [L42_09](#) [L42_10](#)
[L42_11](#) [L42_12](#) [L42_13](#) [L42_14](#) [L42_15](#) [L42_16](#) [L42_17](#) [L42_18](#) [L42_19](#) [L42_20](#)
[L42_21](#) [L42_22](#) [L42_23](#)

[L43_01](#) [L43_02](#) [L43_03](#) [L43_04](#) [L43_05](#) [L43_06](#) [L43_07](#) [L43_08](#) [L43_09](#) [L43_10](#)
[L43_11](#) [L43_12](#) [L43_13](#) [L43_14](#) [L43_15](#) [L43_16](#) [L43_17](#) [L43_18](#) [L43_19](#) [L43_20](#)
[L43_21](#) [L43_22](#) [L43_23](#) [L43_24](#)

[L44_01](#) [L44_02](#) [L44_03](#) [L44_04](#) [L44_05](#) [L44_06](#) [L44_07](#) [L44_08](#) [L44_09](#) [L44_10](#)
[L44_11](#) [L44_12](#) [L44_13](#) [L44_14](#) [L44_15](#) [L44_16](#) [L44_17](#) [L44_18](#) [L44_19](#) [L44_20](#)
[L44_21](#) [L44_22](#) [L44_23](#) [L44_24](#) [L44_25](#) [L44_26](#)

[L45_01](#) [L45_02](#) [L45_03](#) [L45_04](#) [L45_05](#) [L45_06](#) [L45_07](#) [L45_08](#) [L45_09](#) [L45_10](#)
[L45_11](#) [L45_12](#) [L45_13](#) [L45_14](#) [L45_15](#) [L45_16](#) [L45_17](#) [L45_18](#) [L45_19](#) [L45_20](#)
[L45_21](#) [L45_22](#) [L45_23](#) [L45_24](#) [L45_25](#) [L45_26](#) [L45_27](#) [L45_28](#) [L45_29](#) [L45_30](#)

[L46_01](#) [L46_02](#) [L46_03](#) [L46_04](#) [L46_05](#) [L46_06](#) [L46_07](#) [L46_08](#) [L46_09](#) [L46_10](#)
[L46_11](#) [L46_12](#) [L46_13](#) [L46_14](#) [L46_15](#) [L46_16](#) [L46_17](#) [L46_18](#) [L46_19](#) [L46_20](#)

[L47_01](#) [L47_02](#) [L47_03](#) [L47_04](#) [L47_05](#) [L47_06](#) [L47_07](#) [L47_08](#) [L47_09](#) [L47_10](#)
[L47_11](#) [L47_12](#) [L47_13](#) [L47_14](#) [L47_15](#) [L47_16](#) [L47_17](#) [L47_18](#) [L47_19](#) [L47_20](#)
[L47_21](#) [L47_22](#) [L47_23](#) [L47_24](#) [L47_25](#) [L47_26](#) [L47_27](#) [L47_28](#)

[L48_01](#) [L48_02](#) [L48_03](#) [L48_04](#) [L48_05](#) [L48_06](#) [L48_07](#) [L48_08](#) [L48_09](#) [L48_10](#)
[L48_11](#) [L48_12](#) [L48_13](#) [L48_14](#) [L48_15](#) [L48_16](#) [L48_17](#) [L48_18](#) [L48_19](#) [L48_20](#)

[L49_01](#) [L49_02](#) [L49_03](#) [L49_04](#) [L49_05](#) [L49_06](#) [L49_07](#) [L49_08](#) [L49_09](#) [L49_10](#)
[L49_11](#) [L49_12](#) [L49_13](#) [L49_14](#) [L49_15](#) [L49_16](#) [L49_17](#) [L49_18](#) [L49_19](#) [L49_20](#)
[L49_21](#) [L49_22](#) [L49_23](#) [L49_24](#) [L49_25](#) [L49_26](#)

[L50_01](#) [L50_02](#) [L50_03](#) [L50_04](#) [L50_05](#) [L50_06](#) [L50_07](#) [L50_08](#) [L50_09](#) [L50_10](#)
[L50_11](#) [L50_12](#) [L50_13](#) [L50_14](#) [L50_15](#) [L50_16](#) [L50_17](#) [L50_18](#)

[L51_01](#) [L51_02](#) [L51_03](#) [L51_04](#) [L51_05](#) [L51_06](#) [L51_07](#) [L51_08](#) [L51_09](#) [L51_10](#)
[L51_11](#) [L51_12](#) [L51_13](#) [L51_14](#) [L51_15](#)

[L52_01](#) [L52_02](#) [L52_03](#) [L52_04](#) [L52_05](#) [L52_06](#) [L52_07](#) [L52_08](#) [L52_09](#) [L52_10](#)
[L52_11](#) [L52_12](#) [L52_13](#) [L52_14](#) [L52_15](#) [L52_16](#)

[L53_01](#) [L53_02](#) [L53_03](#) [L53_04](#) [L53_05](#) [L53_06](#) [L53_07](#) [L53_08](#) [L53_09](#) [L53_10](#)
[L53_11](#) [L53_12](#) [L53_13](#) [L53_14](#) [L53_15](#) [L53_16](#) [L53_17](#) [L53_18](#) [L53_19](#) [L53_20](#)

[L54_01](#) [L54_02](#) [L54_03](#) [L54_04](#) [L54_05](#) [L54_06](#) [L54_07](#) [L54_08](#) [L54_09](#) [L54_10](#)
[L54_11](#) [L54_12](#) [L54_13](#) [L54_14](#) [L54_15](#) [L54_16](#) [L54_17](#) [L54_18](#) [L54_19](#)

[L55_01](#) [L55_02](#) [L55_03](#) [L55_04](#) [L55_05](#) [L55_06](#) [L55_07](#) [L55_08](#) [L55_09](#) [L55_10](#)
[L55_11](#) [L55_12](#) [L55_13](#)

[L56_01](#) [L56_02](#) [L56_03](#) [L56_04](#) [L56_05](#) [L56_06](#) [L56_07](#) [L56_08](#) [L56_09](#) [L56_10](#)
[L56_11](#) [L56_12](#) [L56_13](#) [L56_14](#) [L56_15](#) [L56_16](#) [L56_17](#) [L56_18](#) [L56_19](#) [L56_20](#)
[L56_21](#) [L56_22](#)

[L57_01](#) [L57_02](#) [L57_03](#) [L57_04](#) [L57_05](#) [L57_06](#) [L57_07](#) [L57_08](#) [L57_09](#) [L57_10](#)
[L57_11](#) [L57_12](#) [L57_13](#) [L57_14](#) [L57_15](#) [L57_16](#) [L57_17](#)

[L58_01](#) [L58_02](#) [L58_03](#) [L58_04](#) [L58_05](#) [L58_06](#) [L58_07](#) [L58_08](#) [L58_09](#) [L58_10](#)
[L58_11](#) [L58_12](#) [L58_13](#) [L58_14](#) [L58_15](#) [L58_16](#) [L58_17](#) [L58_18](#)

[L59_01](#) [L59_02](#) [L59_03](#) [L59_04](#) [L59_05](#) [L59_06](#) [L59_07](#) [L59_08](#) [L59_09](#) [L59_10](#)
[L59_11](#) [L59_12](#) [L59_13](#) [L59_14](#) [L59_15](#) [L59_16](#) [L59_17](#) [L59_18](#) [L59_19](#) [L59_20](#)

[L60_01](#) [L60_02](#) [L60_03](#) [L60_04](#) [L60_05](#) [L60_06](#) [L60_07](#) [L60_08](#) [L60_09](#) [L60_10](#)
[L60_11](#) [L60_12](#) [L60_13](#) [L60_14](#) [L60_15](#) [L60_16](#) [L60_17](#) [L60_18](#) [L60_19](#) [L60_20](#)
[L60_21](#) [L60_22](#) [L60_23](#) [L60_24](#) [L60_25](#) [L60_26](#) [L60_27](#) [L60_28](#) [L60_29](#) [L60_30](#)
[L60_31](#) [L60_32](#) [L60_33](#) [L60_34](#) [L60_35](#) [L60_36](#) [L60_37](#)

Tarbell Course

by Harlan Tarbell

Electronic Version © 2001 Lybrary.com www.lybrary.com

Allowed Usage:

This ebook is for home use only. Renting or public viewing of this ebook is prohibited.

Crime Watch:

We reward any tips and information which lead to the conviction of illegal copying activity with 50% of the punitive damages placed to our credit. Please help us to identify criminals. At the end of the day illegal copying will increase ebook prices for you or make such products impossible altogether. Please contact us at crime@lybrary.com or any other of our email and mailing addresses. You can also fax us at (972) 509 4714.

Please send error corrections to errors@lybrary.com.

history:

1st edition, 1920, Harlan Tarbell

later reprinted

LESSON

[1](#) [2](#) [3](#) [4](#) [5](#) [6](#) [7](#) [8](#) [9](#) [10](#)
[11](#) [12](#) [13](#) [14](#) [15](#) [16](#) [17](#) [18](#) [19](#) [20](#)
[21](#) [22](#) [23](#) [24](#) [25](#) [26](#) [27](#) [28](#) [29](#) [30](#)
[31](#) [32](#) [33](#) [34](#) [35](#) [36](#) [37](#) [38](#) [39](#) [40](#)
[41](#) [42](#) [43](#) [44](#) [45](#) [46](#) [47](#) [48](#) [49](#) [50](#)
[51](#) [52](#) [53](#) [54](#) [55](#) [56](#) [57](#) [58](#) [59](#) [60](#)

INDEX

Key

T Trick
P Principle
I Illusion
E Explanation
F Flourish

Key		Page	Lesson
-----	--	------	--------

CARD MAGIC

T	A Book and a Card	10-12	19
T	A Mysterious Discovery	8-10	15
P	An Emergency Card Force	3	14
T	A Psychological Impossibility	11-14	9
P	Back Hand Palm	5-6	17
T	Bewitched Bananas	16-20	14
T	Bewitched Rising Cards and Envelope	5-7	19
T	Book and a Card, A	10-12	19
P	Bottom to Top Shifts	4	15
T	Card and Banana	10-16	14
T	Card Effects 12 Impromptu	1	34
F	Card Flourishes		
	1 - The Cascade	23	35
	2 - The One Handed Cut	23-24	35
	3 - The Ribbon Drop	22	35
T	Card Fountains	27-30	36
T	Card Levitation	25-27	36
T	Card Stab	7-11	13
T	Cardini's Rising Cards	1-5	18
P	Card Principles	1	12
T	Cards Enchanted and Envelopes	1-5	19
T	Cards, Envelopes and Hat	15-19	15
T	Cards Rising Thru Air	20-25	36
T	Cards that Pass in the Night	1-11	12
P	Cards up the Sleeve	11-19	12
P	Cards up the Sleeve (Shoulder Method)	19-22	12
T	Cascade from Boy's Nose	2	36
T	Circus Trick	6	36
E	Cloth Changing Bag (How to Make)	18	14

T	Conjurer's Touch, The	5-8	15
E	Easy Method of Forcing Cards	2-5	36
E	Emergency Card Force, A	3	14
T	Enchanted Cards and Envelope	1-5	19
P	False Counting No. 2	11-12	36
P	False Count	5	12
P	Flash Card Production	3-6	17
P	Force, The	1	14
P	Force Behind Performer's Back	5	36
P	Force by Naming Number	10	36
P	Force with Unprepared Cards	1	14
P	Force with Die	10	36
E	Forcing Cards - Easy Methods	2-5	36
E	Forcing Bottom Card	4-5	36
P	Forcing one of four cards on table	9-11	36
P	Free Choice Forcing	9	36
T	Four Ace Effects	14-16	36
T	Magnetic Knife, The	15-16	13
T	Mystic Aces	19-20	36
T	Slippery Aces	16-19	36
E	Guide to Card Positions	1-2	15
P	How to get card from middle of deck to bottom of deck	6-7	13
P	Index Finger Shift	4	15
T	"Marvello"	10-15	15
T	Mathematical Card Force	3-5	36
P	Misdirection Palming	13	12
T	Mysterious Bookmarks	7-10	19
T	Mysterious Discovery	8-10	15
T	Mystery of the Glass House	6-9	17
T	New Era Version of Card thru Hdkf.	4-7	16
P	Oblique Slip up Palm	3	15
P	Oblique Slip up Palm Shift	4	15
P	Palm False Count	13-14	36
P	Pick up False Count	13	36
P	Pivot Card Vanish	22	12
P	Pocket Concealment of Cards	13-14	12
P	Principle of Card Effects	1	9
P	Principles of Cards	1	12
P	Principles of Palming and Shifts	3-5	15
T	Producing Card from Whole Orange	4-10	14
T	Production of Cards from Mouth	1-2	36
T	Psychological Impossibility	11	14
P	Put Back False Count	12-13	36
P	Regular Pass, The	5-6	13
P	Riffle Force	7-8	36
P	Riffle Force with Unprepared Cards	8-9	36

P	Right Angle Kick in Palm	3-4	15
T	Rising thru Air Cards	20-25	36
T	Rising Card Escape	1-5	9
T	Rising Cards and Card Case	5-8	18
T	Rising Cards from Glass Tumbler	9-15	18
T	Rising Cards thru Handkerchief	10-11	16
T	Rising Cards thru Hat	12-13	19
T	Rising Cards Out of a Hat	13-14	19
T	Rising card Principles and Suggestions	13-14	18
T	Sealed Card Mystery	6-11	9
T	Self-Contained Card Vanish	16-17	12
E	Sleight of Hand with Cards	1	35
	Back and Front Hand Palming	1-4	35
	Bottom Dealing	19-20	35
	Color Changes with Cards	9-12	35
	Dealing Seconds	20	35
	Double Card Change	15-16	35
	Double Card Lift	3-5	9
	Modern Card Change	20-21	35
	Open Finger Color Change	12-15	35
	Push Up Color Change	14-15	35
	Producing a Card	4	35
	Producing Cards in a Fan	4	35
	Simplified Back and Fron Hand Palm	5-9	35
	Simplified Pass	2-3	9
	Single Hand Card Change	21-22	35
	Slip Up Color Change	16	35
	The Slip Change	9	9
	Thumb Steal Color Change	13	35
	The False Shuffle	3	9
	To Produce a Card	4	35
	To Produce Cards in a Fan	4	35
	Top Card Change (3 Methods)	16-18	35
P	Slip of Paper Force	11	36
T	Slit Corner Envelope	11	9
P	Slip of Paper Force	11	36
T	"Snap It"	1-3	17
P	Thumb and Little Finger Shift	5	15
T	Three Cards thru Handkerchief	7-10	16
T	The Slit Corner Envelope	11	9
P	Suggestions - Rising Card Principles	13-14	18
T	Twelve Impromptu Effects with Cards	1	34
	1 - A Baffling Discovery	1-3	34
	2 - Another Method for Card in Pocket	17-18	34
	3 - Birds of a Feather	5-7	34
	4 - Card Appearance at Selected Number	9-11	34

	5 - Find the Burglar	13-15	34
	6 - Location of Cards in a Hat Shuffle	20-21	34
	7 - Royal Card Discovery	3-5	34
	8 - The Thoughtful Joker	7-9	34
	9 - The Change About Card	11-13	34
	10 - The Mystic Card Clock Dial	18-19	34
	11 - Thought Location	15-16	34
	12 - Selected Cards from Spectator's Pocket	21-22	34
P	Various Card Principles of Palming and Shifts	3-5	15
	Right Angle Slip Up Palm	3	15
	Oblique Slip Up Palm	3	15
	Right Angle Kick in Palm	3-4	15
	Oblique Slip Up Palm Shift	4	15
	Index Finger Shift	4-5	15
	Thumb-Little Finger Shift	5	15
	X-Ray Cards	14-17	29
	X-Ray Knife	12-14	13

CHEMICAL AND MECHANICAL MAGIC

T	A Cooking Lesson	21-23	44
T	A Magical Transformation	18-21	44
T	A Novel Transmission of Smoke	1-3	44
T	Bottle, Bottle, Where's the Bottle?	12-18	44
E	Chemical and Mechanical Magic	1	44
T	Comedy Version of The Wandering Glass and Bottle	12-14	44
T	The Wandering Glass and Bottle	7-12	44
T	The Welch Rarebit	23-26	44
T	The Wine and Water	3-6	44

CIGARETTE MAGIC

T	An Odd Cigarette Vanish	19-20	33
T	Asbestos Palm, The	10-11	2
T	Burning Borrowed Handkerchief	12-14	2
T	Cardini's Floating Cigarette	20-22	33
T	Catching Cigarettes in the Air	17-19	33
E	Cigarette Manipulation	1-11	33
	1 - Burning Cigarette and Silk Handkerchief	10-11	33
	2 - Change Over Palm	9-10	33
	3 - Front and Back Hand Palm	3-4	33
	4 - Multiplying Cigarettes	8-9	33
	5 - Phantom Cigarette	11-12	33
	6 - Pivot Vanish	3	33
	7 - Pick Up Vanish	2-3	33
	8 - Pull Away Vanish	5-6	33
	9 - Push In Vanish	1-2	33
	10 - Throwing Vanish	4-5	33
	11 - To Produce Cigarette from Ear	6	33
	12 - To Swallow a Cigarette	6-7	33
	13 - To Vanish Cigarette up Nose	6	33

	<u>14 - Vanishes and Productions of Paul Fuchs</u>	7-8	33
T	<u>Dollar Bill in the Cigarette, The</u>	14-17	33
T	<u>Enchanted Paper, The</u>	14-17	2
T	<u>Mystery of the Burning Cigarette, The</u>	7-10	2
E	<u>Thumb Tip Manipulation</u>	11	2
T	<u>To Produce Lighted Cigarette from Box</u>	22-23	33
T	<u>Vanishing Cigarette, The</u>	13-14	33
T	<u>Vanishing Pencil, The</u>	14	33

COIN MAGIC

P	<u>Angles of Visibility</u>	12-13	1
T	<u>Coin Envelope and Handkerchief</u>	7-10	23
T	<u>Coin in the Magical Envelopes</u>	10-16	22
P	<u>Coin Vanish - Wrapped in Piece Paper</u>	10-12	23
T	<u>Dissolving Coin Trick</u>	13-16	1
P	<u>Elusive Change Over Palm</u>	12-13	21
P	<u>Finger Palming</u>	14-15	1
P	<u>Holds Used in Coin Sleights</u>	4-5	21
T	<u>Homing Coins</u>	1-6	22
T	<u>Invisible Money Transit</u>	6-10	22
P	<u>Manipulative Methods for Vanishing a Coin</u>	5-12	21
T	<u>Miser's Dream</u>	1-7	23
P	<u>Palming Used in Coin Sleights</u>	2-4	21
T	<u>Passe Coins from Hand to Hand</u>	16-19	23
T	<u>Passe Passe Coins and Glasses</u>	12-16	23
T	<u>Phantom Coins</u>	20	23
E	<u>Sleight of Hand with Coins</u>	1-2	21
P	<u>Thumb Change Over Palm</u>	13-14	21
P	<u>To Get Rid of Coin After Vanishing it in Hand</u>	12	21

EGG MAGIC - COAT AND HAT PRODUCTIONS

E	<u>Body Load</u>	8	24
T	<u>Changing Rabbit to Box of Candy</u>	19-23	43
T	<u>Chicken Produced from Gentleman's Coat</u>	18	43
T	<u>Comedy Egg Production</u>	1-7	43
T	<u>Easy Method for Rabbit from Hat Production</u>	13	43
T	<u>Egg Bag</u>	6-18	24
T	<u>Eggstraordinary-Eggsplanation</u>	16-20	32
T	<u>Unexpected Rabbit Production</u>	10-12	43
E	<u>General Hat Productions</u>	24	43
E	<u>How to Make the Egg Bag</u>	7-8	24
T	<u>Humpty Dumpty Outdone</u>	1-5	24
T	<u>Production of Bottle of Milk or Liquor from Gent's Hip Pocket</u>	19	43
T	<u>Rabbit from Hat - Novel Production</u>	12-13	43
T	<u>Rabbit Production</u>	7-9	43
T	<u>Rabbit Production from Paper Ribbon</u>	14	43
T	<u>Rabbit Production from Gent's Coat</u>	14-17	43
T	<u>Sausages from Boy's Coat</u>	23	43

T	Silks and the Rabbit	13-14	43
---	--------------------------------------	-------	----

HISTORY OF MAGIC

	Development of Superstition	1-3	4
	History of Magic	1-13	1
	History of Sleight of Hand	1-3	2
	Magic and the Science of Medicine	1-2	6
	Magic and Religion	1-3	5
	Magic as an Aid to Business	3	6
	Magic as a Hobby	3-4	6
	Magic as a Science	4-5	1
	Magic Is Educational	4-5	8
	Necromancy and Divination	1-3	3
	Relation of Magic to other Sciences	1-4	8

ILLUSIONS

I	A Daughter of the Sun	8-11	52
E	Black Art Apparatus	2-6	52
E	Black Art Illusions	2	52
E	Black Art Table	1-4	54
I	Bon Bon Paper Bag Escape, The	20	53
E	Building Illusions	1	52
I	Canvas Box Mystery, The	9-13	53
I	Chinaman, The Ghost and The Cat, The	1-15	57
I	Chinese Pigeon Production, The	9-11	54
I	Doll House Illusion, The	10-13	55
I	Egyptian Mummy, The	1-6	55
I	Elusive Hindu, The	6-8	52
E	Escape and Substitution Illusion	1	53
E	How to Operate Black Art Wells	4-7	54
I	Indestructible Girl, The	8-11	56
I	Mystery of the Dancing Girls, The	7-9	55
I	Mystery of King Tut, The	3-13	51
I	Mystery of the Girl in the Trunk, The	11-14	52
I	Mystery of the Three Ghosts, The	15-17	57
I	Packing Box Escape, The	13-18	53
I	Paper Bag Escape, The	18-20	53
I	Penetrating Steel Bars, The	6-8	56
I	Phantom of the Circus, The	2-18	58
I	Phantom Flight, The	14-16	52
I	Sawing a Woman in Half	11-22	51
I	Substitution Trunk Mystery	1-9	53
I	Sword Box, The	3-5	56
I	Sword Stabbing Illusion	1-2	56
I	Thayer's Super Vanish of Doves	11-19	54
I	Treasure Chest, The	7-8	54
E	Why Simplicity Is Essential	1-2	51

MIND READING AND SPIRITUALISTIC MAGIC

T	Blindfold Card Reading	17-20	31
---	--	-------	----

T	Cabinet Seance, The	13-18	46
T	Cabinet Seance Tie	18-19	46
T	Crystal Ball	3	31
T	Dark Circle, The	6-7	46
T	Dark Seance at the Table, The	1-6	46
T	Distant Mental Communication	15-17	31
T	Double Slate Writing	20-24	45
T	Dr. Bridges' Thought Production	9-11	46
T	Gysel's Mysterious Lights	8	46
T	Living and the Dead, The	5-14	45
E	Methods of Mind Reading	1	31
T	Mind Reading Act	8-12	29
T	Modern Crystal Gazing Act	2-6	31
E	Modern Spiritualistic Magic	4-5	45
T	Mystic Discovery, A	20-24	31
T	"One Man" Mind Reading Act	10-15	31
T	Pencil Rapping	26-27	45
E	Presenting the Mind Reading Act	17-22	31
T	Psychic Paper, The	17-21	45
T	Rapid Mental Transfer	6-10	31
T	Siberian Chain Escape, The	11-13	46
T	Single Slate Writing	24-26	45
T	Spirit Photography	14-17	45
E	Spiritualistic Magic	1-3	45
E	Spiritualism and Magic	3-4	45
T	Telepathic Messages	22-25	29
T	Throw Away Coat Tie, The	19-20	46
T	Touch of Mysterious Fingers, The	27-30	45
E	Types of General Questions in Mind Reading Act	21-22	29

MISCELLANEOUS EXPLANATIONS

	Advertising and Publicity	6-11	30
	Advertising and Publicity, Advanced	1-37	60
	Angles of Visibility	12-13	1
	Apparatus Free	6-7	1
	Arrangement of Programs	11-12	20
	Arrangement of Stage Settings	20	30
	Arranging a Program	11-14	30
	Art of Misdirection	4-6	3
	Character Analysis as Related to Magic	1-16	40
	Create Interest in Audience	5	20
	Creating of Effects	2	29
	Confidence and Enthusiasm	1-2	10
	Dignity and Appearance	2-3	10
	Divisions of Modern Magic	1	29
	Ethics at a Magic Performance	2-3	32
	Experiments of Super Mentality	3-4	29

<u>How My Course Saves You Money</u>	3-4	25
<u>How to Deal with Wiseacres</u>	9-10	10
<u>How to Get Bookings</u>	5-6	30
<u>How to Get Started Professionally</u>	3-4	30
<u>How to Please Your Audience</u>	1-2	20
<u>How to Present a Program</u>	6-7	10
<u>How to Secure the First Engagement</u>	1	20
<u>Importance of Patter</u>	11	1
<u>Importance of Practice</u>	10-11	1
<u>Individuality - Modern Times</u>	3-4	20
<u>Keeping Up with the Times</u>	2-4	20
<u>Magic Develops Personality</u>	3-4	5
<u>Maintain a Healthy Attitude Towards Magic</u>	5-6	20
<u>Making an Impression</u>	4-5	20
<u>Making Money with Magic</u>	1-16	30
<u>Making Money for Others</u>	3	30
<u>Making the Box Office Pay</u>	1-20	59
<u>Making Magic Pay</u>	2-3	60
<u>Magic as a Science</u>	4	1
<u>Naturalness in Performing</u>	9-10	1
<u>People Willing to Believe</u>	3-4	3
<u>Personality and Magnetism</u>	3	10
<u>Play Up Your Individuality</u>	5	10
<u>Power of Suggestion</u>	4-5	2
<u>Power of Suggestion Has Over You in Magic</u>	5-6	2
<u>Power of Suggestion - Its Influence</u>	6	2
<u>Presentation</u>	2	29
<u>Professional Attitude</u>	7-8	1
<u>Programs Arranged</u>	12	20
<u>Programs Outlined</u>	15-19	30
<u>Radiate Good Will and Pleasantness</u>	2	10
<u>Romance in Magic</u>	1-2	58
<u>See Other Magicians at Work</u>	10	10
<u>Showmanship</u>	3-5	10
<u>Simplicity of Tricks</u>	9	1
<u>Simplicity Is the Keynote of Tarbell Course</u>	1-2	26
<u>Specialization</u>	2	29
<u>Stage in Modern Times</u>	4	20
<u>Staging Your Program</u>	19-20	30
<u>Suggestions for Programs</u>	7-8	10
<u>The Importance of Little Tricks</u>	1	11
<u>Unlimited Opportunities in Magic</u>	1	29
<u>What the Public Wants</u>	2	20
<u>What to Charge</u>	5	30
<u>Where to Start</u>	4-5	30
<u>Why Simplicity in Illusions Is Essential</u>	1-2	51

	Why You Are Never to Repeat	12	1
	Write About Programs	11-12	10
	Your First Appearance	1	10
	Your Relation to Other Magicians	1-3	32

BILLIARD BALL AND NOVELTY MAGIC

T	Adam and Eve	2-13	41
T	A Mysterious Ball Transportation	17-19	41
P	Billiard Ball Manipulation	1-2	41
T	Cigar from Pocketbook	22-23	30
T	"Clean Cut" Color Changing Handkerchief, The	1-4	42
T	Cups and Balls	19-25	41
T	Elusive Rainbow, The	8-11	42
T	Houdini's Famous Needle Trick	1-5	27
T	King Solomon's Marriage Bands	9-11	20
T	Magic Chocolates, The	16-18	42
E	Novelty Ideas	1	42
T	Nursing Bottle from a Hat	23	42
T	Popping Corn in a Hat	19-23	42
T	Rainbow Billiard Balls	13-17	41
T	Routine with Billiard Balls, The	2	41
T	Spot the Red	11-12	42
T	Vanishing Wand, The	6-9	20
T	Vice Versa Color Changing Handkerchief, The	5-8	42
T	Wand from Card Case	23-24	30
T	Wand from Pocketbook	21-22	30
T	Watch the Lemon	12-15	42

ORIENTAL MAGIC

T	Chelafo's Knot	14-15	37
T	Chinese Burning Tapes, The	17-19	37
T	Chinese Color Changing Coins	1-6	37
T	Chinese Sticks, The	5-10	38
T	Chinese Linking Rings	1-3	47
T	Chinese Production of Doves	17-18	49
T	Chinese Production of Four Bowls of Water	11-12	49
T	Ching-a-Ling Chinese Lantern Productions	6-10	48
T	Chink-a-Chink	7-9	37
T	Ching Ling Foo's Magic Water Can	21-22	49
T	Climbing Balls, The	10-12	38
T	Disappearing Grain, The	12-13	38
T	Hindu Cut and Restored Turban	20-23	37
T	Hindu Jar of Grain	13-14	38
T	Hindu Mango Tree Growth	10-14	48
T	Jap O Tie	1-3	38
T	Kolar's Balloon and Silks	5-6	48
T	Modern Production of Bowl of Water on Table	12-14	49
T	Mysterious Self Filling Lota, The	19-21	49
T	Mysterious Japanese Thumb Tie	15-17	37

T	Mystery of the Paper Ball, Egg, Frog, and Chicken	22-25	49
T	Mystic Knots, The	11-13	37
T	Mystic Smoke, The	3-4	38
E	Oriental Magic	1	37
T	Phantom Knot, The	9-11	37
T	Production of Large Bowl of Water	2-6	49
T	Production of Stack of Four Bowls of Water	7-10	49
T	Productive Japanese Lantern, The	14-19	38
T	Vanishing Bowl of Water, The	14-16	49
T	Tarbell's Hindu Plant Growth	14-20	48
T	Tarbell's Mysterious Fire Crackers	1-4	48
T	To Untie Knots Magically	13	37
T	Weber's Emergency Routine of Chinese Linking Rings	23-28	47

PAPER MAGIC AND MAGIC WITH NUMBERS

T	Chess Knight Tour	4-8	29
T	Chinese Paper Mystery	5-8	4
T	Explanation of Japanese Torn and Restored Napkin	14-17	4
T	Hindu Paper Tearing	5-8	5
T	Japanese Torn and Restored Napkin	12-14	4
T	Milady's Parisienne Hat	8-12	5
T	Mystery of Traveling Numbers	5-9	8
T	Patriotic Paper Balls	12-16	5
T	Rapid Banking	14-18	8
T	Spirit Mathematician	9-14	8
T	Wintertime in China	8-12	4
T	The Numbers on the Arm	14	8
T	Yogi's Prediction	12-14	29

RABBIT AND OTHER ANIMAL MAGIC

T	Changing Rabbit into Box of Candy	19-23	43
T	Chicken Produced from Gentleman's Coat	18	43
E	Chinese Box Vanish for Rabbit	30-31	30
T	Easy Method for Rabbit from Hat Production	13	43
E	Effects with Rabbits	4	25
T	Milady's Hat Box Rabbit Vanish	12-14	25
T	"Modern" Rabbit Production	4-9	25
T	Production of Rabbit from Silks	29-30	30
E	Rabbit Bags - How to Make	31-32	30
E	Rabbit Bag	13	25
E	Rabbit Box and Table, How to Construct	6-10	25
T	Rabbit from Hat, Novel Production of	12-13	43
T	Rabbit Production, An Unexpected	10-12	43
T	Rabbit Production	7-9	43
T	Rabbit Production from Paper Ribbon	14	43
T	Rabbit Production from Gentleman's Coat	14-17	43
E	Rabbit Traveling Bag	27	30
E	Rabbit Bags, Other	31-32	30

T	Silks and the Rabbit	13-14	43
E	Suggestions for Handling Rabbits	9-10	43
T	"Sucker" Box Vanish	9-12	25
T	"Unique" Rabbit Box Production	15-16	25

REVIEW OF LESSONS

	Review of Principles	4	4
	Review of Lessons 1 - 12	1-4	13
	Review of Lessons 13 - 24	1-3	25
	Review of Lessons 25 - 37	23-24	37
	Review of Lessons 38 - 49	25-26	49

ROPE, TAPE AND RUBBER BAND TRICKS, TIES AND ESCAPES

T	Coats, Ropes and Rings	9-12	7
T	Coats, Tapes and Rings	1-8	7
T	Comedy Version of Germaine Cord Effect	7-10	6
T	Japanese Thumb Tie, The	10-17	11
T	Impromptu Cut and Restored Cord Effect	10-14	6
T	Jumping Rubber Band, The	4-6	11
T	Kellar's Cut and Restored Cord	4-7	6
T	Magic Orange, The	16-19	7
T	Metal Ring on String	7-9	3
T	Patriotic Rings on Strings, The	9-12	3
T	Penetrating Ring, The	1-4	11
T	Prisoner's Escape, The	13-16	7
P	Rope and Tape Principle, The	1-2	7
T	Tape Release, Another	21	7
T	Tarbell Rope Mystery, The	1-2	50
T	Tarbell Rope Mystery, Method A	1-11	50
T	Tarbell Rope Mystery, Method B	11-12	50
T	Tarbell Rope Mystery, Method C	13-14	50
T	Tarbell Rope Mystery, Method D	14-17	50
T	Tarbell Rope Mystery, Method E	17-18	50
T	Tarbell Rope Mystery, Method F	18	50
T	Thumb Tie with Rubber Bands, The	6-10	11
P	To Make Cord for Tying	16-17	11
T	Vanishing Ring on String, The	12-13	3
T	Walking Through Tapes	19-21	7

SILKS, RIBBONS AND HANDKERCHIEF MAGIC

T	Birth of Old Glory, The	25-27	39
T	Blending of Colors	18-21	40
T	Candle, the Silk and the Paper Tube, The	16-18	28
T	Card and Ribbon Mystery	5-8	26
T	"Clean Cut" Color Changing Handkerchief, The	1-5	42
E	Changing Bag - How to Handle	29-31	32
T	Chinese Box Production	25-27	30
T	Cut and Restored Ribbon, The	2-5	26
T	De Luxe Silk Production from Hat	27-28	30
T	Dying Handkerchiefs, The	16-24	39

T	Educated Knot, The	18-20	28
T	Eggs-Traordinary Eggs-Planation	16-20	32
T	Egg Glass and the Handkerchief, The	1-6	28
T	Elusive Rainbow, The	8-11	42
T	Elusive Silks	29-33	32
T	Ghostly Ribbon, The	8-10	26
T	Goldin's Double Handkerchief Color Change	14-16	39
E	Handkerchief Ball - How to Use the	1-4	39
E	Handkerchief Pull - How to Use the	13	28
T	Indestructible Handkerchief, The	27-32	40
T	Mystic Knots	4-12	32
	Chain Tie and Release with Bow Knot	12	32
	Dissolving Single Knot	5-6	32
	Fade away Double Knot	7	32
	Leg Tie and Release with Handkerchief	9-10	32
	Magical Bow Knot	10-11	32
	Pull Away Single Knot	4-5	32
	Quick Release Double Knot	8-9	32
	Speedy Single Knot	6-7	32
	The Speedy Single Knot	6-7	32
T	Mystic Ribbons, The	21-24	40
T	One Man Handkerchief Vanish	22-25	32
T	Penetrating Pocket Knife, The	24-27	40
E	Principles of Handkerchief Magic	17-18	40
T	Repeat Handkerchief Vanish	12-15	32
E	Silk Handkerchief Magic	3-4	32
T	Silk Counting Version, Another	27-29	32
T	Silks and the Flame, The	11-16	28
T	Soup Plate and Handkerchief, The	4-7	39
T	Silk Production from Hat	24-25	30
T	Silks and the Rabbit	13-14	43
T	Spirit Communication, A	10-15	26
T	Spot the Red	11-12	42
T	"Sucker" Handkerchief Vanish	20-22	32
E	Subject of Silks, The	1	28
T	Sympathetic Silks, The	25-27	32
T	Tarbell's Color Changing Handkerchief	12-14	39
T	Twentieth Century Silks, The	8-12	39
T	Two Soup Plates and Handkerchief	7-9	39
T	"Vice Versa" Color Changing Handkerchief, The	5-8	42
T	Wandering Handkerchief, The	6-11	28
T	Wandering Ribbon	15-17	26

THIMBLE MAGIC

	Preliminary Practice with Thimbles	7-12	27
	1. Back and Front Hand Palming with Thimbles	8-9	27
	2. Band and Front Hand Palming 2	18	27

	<u>3. Change Over Palm - Thimble</u>	10	27
	<u>4. Head Vanish</u>	19	27
	<u>5. Mouth Vanish</u>	19	27
	<u>6. Ear Vanish</u>	20	27
	<u>7. Outline of Thimble Act</u>	25	27
	<u>8. Production of Thimbles</u>	9-10	27
	<u>9. Production of Thimbles from Empty Left Palm</u>	13	27
	<u>10. Production of Thimbles from Thumb Palm</u>	13	27
	<u>11. Pull Away Thimble Vanish</u>	13	27
	<u>12. Second Finger Thimble Hide-Away</u>	12	27
	<u>13. Side Swing Over Jump</u>	21	27
	<u>14. Slow Thimble Vanish in Hand</u>	11-12	27
	<u>15. Thimble Hat Production</u>	24	27
	<u>16. Thimble Jump from Hand to Hand</u>	21	27
	<u>17. Thimble Trouser Leg Production</u>	24	27
	<u>18. Throw Away Vanish</u>	14	27
	<u>19. Thumb Down Vanish</u>	16	27
	<u>20. Thumb Palming a Thimble</u>	7-8	27
	<u>21. Transfer Color Change</u>	17-18	27
	<u>22. Two in one Color Change and Change Back to Original Colors</u>	14-16	27
T	<u>A Thimble Act</u>	5-23	27
T	<u>Interesting Thimble Vanishes</u>	28-29	27
T	<u>The Miser's Dream with Thimbles</u>	26-27	27

LESSON 1

THE HISTORY OF MAGIC

I want you to go with me into far away lands and into the long ago to get a glimpse of the beginnings of the Mystic Art. This Art has been practiced from time immemorial, and from the faint echoes of the ages comes here and there an intimation that with Magic are bound up the very lives of the ancients. In one remote corner of the globe we see how Magic played a vital part in religion; in another distant spot we find that Magic was a part of the daily lives of the people; and in other lands we see the family and the social relationships of the people under the powerful influence of Magic.

MAGICIANS IN THE BIBLE

The first record we have of Magic in ancient times is in the Bible. You remember the story of the Pharaoh's dream of seven full ears of corn and seven withered ears, of seven fat cows and seven lean cows. The Pharaoh was much perturbed by the dream and summoned all the magicians of the realm to come and interpret it. None of them was able to explain the dream until Joseph was called and gave the interpretation of seven years of plenty and seven years of famine for Egypt.

The second time we read of Magic in the Bible is the story of the plea of Moses and Aaron before the Egyptian King to release their people so that they might sojourn to another land. To prove that his mission was of divine origin, Moses turned his rod into a serpent. All of the magicians of the land were asked to do the same but failed.

All through the Bible, Magic is mentioned again and again, indicating that Mysticism played a tremendous part in the life of the ancients.

The Kings of the Jews, we are told, called upon the soothsayers and magicians to interpret and foretell events for them. Imagine the power of the magician! The very destinies of the people depended on their acts and ideas. For, who would dare to go contrary to these magicians?

The Egyptians then are the first people of whom we have any record who were distinguished for proficiency in Magic.

MAGI OR WISE MEN OF THE EAST

After the Old Testament stories about Magicians, we find scattered bits of information about the Magi or Wise Men of the East. These men lived in Egypt, Babylonia, Persia, and India. It seems that these men had gained more education than the masses of the people and consequently were admired for their knowledge. They were eager

for even more esteem from their inferiors and so developed the Art of mystifying the people and making it seem that they had supernatural powers. They gained great influence as a result of their Mystic Art.

In the New Testament Simon Magus is mentioned as a Magician. He is said to have bewitched the people. Some of his wonderful feats were to make himself invisible and to free himself from bonds and chains.

GREEK MYSTICS

Historians tell us something of the early Greeks in relation to Magic. They believed that supernatural powers mixed with human affairs. Their gods were half human creatures with the powers of performing supernatural acts. From the hundreds of fascinating stories of Greek Magic, let me tell you just one.

Circe was a beautiful creature who enchanted men with her charms. Whenever a Grecian beheld her, he could not resist her spell and fell into her power. She lured the bewitched men to her castle and there transformed them into hogs. This is only one of the many interesting tales of Magic in ancient Greece.

There were also the Greek Oracles, which played an important part in Greek life. The Oracle of Delphi is the one famed in story for her mystic influence over the imaginations and the very lives of the Greeks.

INFLUENCE OF MAGIC IN ROME

You remember the story of Caesar's death – how he was warned again and again by the soothsayer to beware of the Ides of March. He ignored the warning and met his death on the Ides of March.

We find that Nero also invoked the Magician's Art. He had murdered his mother, Agrippina, and sought to have her spirit conjured up by the Magicians so that he could pray her forgiveness.

NEW ERA IN MAGIC

This covers what knowledge we have of ancient Magic and brings us to a new era in the Art of Magic, about 300 A. D.

It was then that Christianity was established as the religion of the Roman Empire. The establishment of the church was supposed to stop the worship of spirits and devils. From that time the power of Magic in religion was lessened, and consequently its character changed somewhat. Magic continued, however, to be a big influence in the lives of all peoples.

BEGINNING OF RECORDS

Every land and every age had its Sorcerers and Magicians. Here and there we pick up some information. Here we find a tale about King Macbeth of Scotland, who conjured up visions

and apparitions; and somewhere else we read of the Popes of the Tenth Century, who practiced Magic and Sorcery. But these little stories are scattered and vague as no records of Magic were kept until the Dark Ages – beginning with the Eleventh Century. Then we begin to get accurate history.

MERLIN AT KING ARTHUR'S COURT

Merlin is the outstanding Magician of the Dark Ages. Though he lived in the last part of the Fifth Century, the records of his performances were not written until the Eleventh Century. He was the wizard at the Court of King Arthur.

The story of Stonehenge is Merlin's most remarkable exploit. Stonehenge is a huge stone monument to the Saxon conquest of England, which you could see today standing on Salisbury Plain in England. The monument originally stood, so the story goes, in Ireland. Merlin commanded that it be moved to England. The ponderous stones would not yield to the efforts of hundreds of men. Merlin looked on for a time and then applied his Magic powers. The stones rose high in the air and flew to Salisbury Plain, where the monument stands now.

LAND OF THE ARABIAN NIGHTS

Asia to all of us stands out as the romantic land of the Mystic. The Arabian Nights tales have held us all spellbound with their fantastic charm. Aladdin and his lamp will live forever in our memories. Though these are just stories, they reflect the thoughts and beliefs of the middle Fifteenth Century.

MODERN MAGIC

We have traveled far in this little history of Magic. I wanted you to have it as a foundation for your study. I wanted you to know how ancient this Art is and what its significance has been. I wanted you to understand the attitude of people toward it – how it has always held them in its spell and always will. You have watched with me its development through the ages up to the beginning of its present stage.

Modern Magic is a long step from the Magic of old. We no longer regard it as supernatural or "black," but we look upon it as a time-honored Art which has stood the test of centuries undiscovered and is now the most entertaining of Arts.

To me, Magic is a Science. It is based on fundamental principles – not on hit or miss methods. I have tried to trace it as a Science and find its beginnings in the latter half of the Thirteenth Century.

FIRST SCIENTIFIC MAGICIAN

Roger Bacon, who lived at that time, was the first scientific Magician. He did not have or pretend to have supernatural powers, but because he got the effects that the Magicians got, he was looked upon as a Mystic.

He was a Magician – but a Scientific one. He studied the Sciences – particularly, the Science of Optics, which plays an important part in Magic. He developed scientific explanations for the magnifying glass and the telescope. His principles governed the effects that Magicians secured then and that Modern Magicians secure, and consequently this marks the beginning of a scientific basis for Magic.

This fact is, of course, not recognized generally. Magic was not regarded then as a Science, nor is it regarded so now by the public. But I do recognize it as such, and I am bringing it forth for the first time in its history as a Science.

This history of Magic will be continued in Lesson 2.

* * *

MAGIC AS A SCIENCE

I could teach you fifty tricks and you would be happy to know them – and perhaps you would think you were a Magician when you had learned these tricks. I know, however, that you wouldn't be a Magician – you would be only a poor amateur.

Imagine going into a chemical laboratory and doing fifty experiments according to directions given you. You would be able to do the experiments in a bungling sort of way. Not knowing the why or wherefore – not knowing the fundamental principles of chemistry – you wouldn't know whether you were getting the correct results or not; unless of course, you got an explosion. Then you would be pretty sure you were wrong.

If you completed the fifty experiments without disastrous results, would you then be a chemist? No. You would have an idea as to what it was all about, but you would forget the experiments and with them you would forget all the chemistry you ever knew. Having no knowledge of the fundamentals, you could never perform other experiments except those taught you -- and even those, you couldn't do well.

So it is with Magic. Your tricks are your experiments which illustrate and fix certain principles in your mind. If I did not lay such stress on fundamentals and principles --even above the actual tricks -- you could never be a Magician. You would do the tricks blindly, not knowing why you must hold your hand at a certain angle or why you must look at a certain point to get the effect. You would have to guess as to whether you were doing it correctly or not. Then your explosion would come. Your secrets would be discovered because you performed like an amateur.

Science, on the other hand, does not permit any guesswork. Everything must be based on sound theories and proved. It does not make experiments its foundation, but builds on fundamentals. In Magic if you master the fundamentals, you have the Master Key. These fundamentals become a part of you.

(1-4)

I don't care how many tricks you forget, if you have the principles down so well that you can recall them at a moment's notice, you can do a great variety of tricks.

Another reason I give you the Science of Magic is that I want you to be able to do other tricks besides the ones I give you. I want you to be able to originate new methods and even new tricks. You can do this easily if you really know the Science of Magic.

I have studied each lesson time and again to make sure that I give you everything to contribute to your understanding of the Science of Magic. I have chosen the trick for each lesson not because I wanted to teach you a trick, but because I wanted to teach you a principle. Each trick illustrates specifically some fundamental and I want you to practice the trick to learn the principle. Do not make learning the trick your sole aim. That is unscientific and unprofessional.

Learn the principle and you will be able to do hundreds of tricks based on the same principle, not only the trick I give you. A Magician is not a Magician because he knows tricks, but because he knows Magic -- the principles, the fundamentals.

So remember you are to become a Scientist in the Realm of Magic and consequently a real Professional.

You as a Scientific Magician will stand out way above the ordinary man in the Profession -- because you have a clearly thought out, scientifically arranged course. You will have a firm foundation of Science through which you can develop and reach unbelievable success as a Magician.

* * *

MY SERVICE TO YOU

I do not think you will find one dull moment in your course. In the first place, because this is a most absorbing subject. The lessons are as interesting as fiction; more interesting, indeed, to the person who enjoys working out problems of Magic. And secondly, because we do not merely study theory, but we actually do the various tricks with the apparatus furnished you just as the expert magician does.

It is my aim to give you the best service possible, to help you in every way in making rapid progress. Before you begin your lessons I want you to have a thorough understanding of the manner in which your work is handled.

A lesson is sent to you every ten days. Study these lessons carefully. Read them over and over again until you are quite familiar with every point contained in them. Every sentence in this course was put there with a purpose. Every word of every lesson is important. You never know when you, as an expert Magician will need the help and advice given on some certain trick. You will use every scrap of information in this course when you become a real expert Magician.

You will be given a file number when your first lesson is sent to you. The rule is that you use this file number,

(1-5)

as well as your name and address on every letter you write. This file number helps me find all information concerning you in a few moments, and prevents confusion, delay, or mistakes through similarity of names. Please remember to place on all communications your name, your address, street number, R. F. D., town, state, and your file number and lesson number.

Use the small envelopes, which I furnish free, for requesting special information and for sending payments to Tarbell System, Inc. Payments should be made by Postal Money Order, Express Money Order, or Bank Draft. Make all remittances payable to Tarbell System, Inc. All personal checks should be certified to avoid delay at this end of the line.

These lessons are sent to you by mail, and I take special pains to put sufficient postage on all supplies sent you. Should you ever receive mail from me on which there is postage due, just send me the envelope with the postage due stamps on, and I will refund the amount. On the other hand, please make sure that there is the proper amount of stamps on the mail you send me. Remember that sealed envelopes are first-class mail and take 2 cents for every ounce, or fraction of an ounce, such as 2, 4, 6, or 8 cents, etc.

All of the lessons are sent out separately, and are to be placed by the student in the strongbox which I am sending you with the first lesson.

Do not hesitate to write to me and ask questions about any points that you do not understand clearly. I want to help you all I can. I want to hear from you often, to know how you like the work, how you are progressing with your studies. Bring me all your problems. I am here to help you.

You will get from this course only as much as you put into it. It is your attitude toward your work that determines your success. The more interest -- real heart and soul interest -- you put into your studies, the more value you will get out of them.

Study and practice regularly. Choose a certain time each day to devote to your lessons. Arrange a schedule for yourself and stick to it. Do not consider these lessons as work, but think of them as an absorbing and valuable recreation. Look forward with eagerness to your study hours. And study regularly.

Remember, you are starting a course of study that may bring you not only great financial success, but happiness as well. Do not let anything interfere with your progress. If you study regularly, if you put the requisite interest and zest into your work, if you try to get as much as you can from this course, you must succeed.

APPARATUS

You will be furnished all the apparatus necessary for the first thirty lessons without any extra charge whatever. This does not include cards, pins, needles, thimbles, pencils,

and other small articles found in every home. In the latter part of the course, you will be given tricks using apparatus which is not furnished free. You may purchase this apparatus from us or make it yourself. None of it is expensive. A few dollars will buy it all if you want it.

MY INSTITUTION

It is my policy to maintain close contact with every one of my students. I am interested in you, in the work you do, in the progress you make, in the jobs you get. Even after you have completed the course you are always free to write in to me and ask for any service and assistance that I can give you.

No one has ever received my certificate without actually finishing the course. This institution, the largest in the world devoted exclusively to teaching the Science of Magic, has an international reputation. It is known in every part of the world.

A certificate from this institution, therefore, is a mark of prestige. It puts the possessor in the ranks of the really Big Magicians.

A beautifully engraved diploma is furnished on graduation to each student. This is your credential as a graduate of the Tarbell System, Inc.

All we ask of you is that you live up to the tradition of this institution by studying faithfully and working with ambition and earnestness toward so splendid a future that some day we can speak your name with pride and say, "He is a graduate of Tarbell System, Inc."

Now, let's get down to the real work.

Your sincere friend,

A handwritten signature in cursive script that reads "Harlan Tarbell". The signature is fluid and elegant, with a large initial 'H' and a long, sweeping underline.

Tarbell System, Inc.

* * *

PROFESSIONAL ATTITUDE

My first word to you now is to get the PROFESSIONAL ATTITUDE. The purpose of my course is to make a Real Magician out of you. I want you to get Professional Skill even if you don't plan to go on the stage. By the end of this course you must be able to do tricks with the same skill as a magician in the profession. You must not be satisfied with less.

I don't care whether you are taking this course for just the purpose of entertaining your own family or whether you are going on the stage -- you will be a Real Magician when you are through. There is nothing half-way about it -- you are going to know Magic.

Now then, with Professional Skill ahead of you as your goal, first of all, get the PROFESSIONAL ATTITUDE. By this I mean:

(1-7)

Study in Earnest

If you had decided that you were going to become a chemist, you would begin studying for that profession. You would take the matter very seriously and would give your time and thought to it so that you would know chemistry thoroughly and could really become a member of the profession.

You must regard your Course in Magic in the same light. I am going to assume that you have chosen Magic as your Profession. Whether you have or not, as I said before, you are going to learn it as a profession.

The lessons make up your text-book. I give you the material you must know just as a chemistry book gives you a knowledge of chemistry. But I give it to you in such a fascinating way. You don't have to dig for dry facts. The lessons are written down just as I would tell these things to you and each move is clearly pictured. I want you to be as much in earnest when you study these lessons as if I were there with you.

Practice Faithfully

To continue our comparison of Magic as a Profession with Chemistry: In learning the Profession of Chemistry you must use the knowledge you get from the text-book. For this purpose you go into the laboratory and test the theories. In learning Magic, your mirror is your laboratory. In it see the results you accomplish. You see your wrong moves -- you see your right moves. So with every minute of practice you get nearer and nearer the right method of doing the different moves upon which the Art is based.

Take palming a coin for example. Palming is one of the fundamentals of Magic. Every time you practice it, you do it more like the man in the Profession does it. When you see the progress you make in each day's practice, you will be filled with enthusiasm -- not only because you will be able to do the trick, but because you will know palming which is used in hundred of tricks. You will find real Professional satisfaction and joy in practicing.

Don't Overlook the Smallest Detail

Many of the details of Magic are so simple that you may make the mistake of thinking them unimportant. That mistake is fatal. When explained, these details are ridiculously simple. Yet, how mystifying to your audience! I need not tell you this. The very tricks which have completely mystified you are based on these simple details.

The Man in the Profession knows this. He knows that the whole Science depends on these small moves and poses. So remember, give strict attention to every detail of every lesson, and regard it with the same importance that the Professional Magician does.

This leads us to a discussion of the simplicity of tricks.

Simplicity of Tricks

I want this fact to sink in: SOME OF THE GREATEST TRICKS AND ILLUSIONS ON THE STAGE ARE UNBELIEVABLY SIMPLE.

Don't forget that you were once one of the spectators and believed these tricks to be almost superhuman feats. Now, when you learn how very simple they are, remember that to those who are not "in the know," they are still deep mysteries.

Do you know that some of the greatest tricks used on the stage today are centuries old? My Linking Ring Trick, for instance, was invented by a Chinaman in 1735, almost 200 years ago. And now in 1926, I use this simple trick. In 200 years no spectator has discovered the secret of it. Yet it is based on the simplest move imaginable.

There are tricks which are so old that their history cannot be definitely traced. Some were supposedly originated by the court jesters of France way back in the Middle Ages. Others are said to have been performed before the notorious Henry VIII., who reigned in England in the first half of the Sixteenth Century, more than 300 years ago. Still others are believed to have come down from antiquity.

These very tricks are some of the simplest in the whole art. They have survived the ages and their secrets are still undiscovered. These same tricks are used today to mystify and entertain people. What further proof do you need that the simplest tricks are often the most mystifying and never lose their charm.

The amateur most often has the idea that a trick must be very elaborate. He thinks that the method of doing it must be very difficult and that there must be great deal of complicated equipment to do it with. I want you to get that idea out of your head and remember that in the simplicity of your tricks lies their great power to mystify the other fellow.

Now we come to one of the most important elements in Magic.

Naturalness in Performing

If I can put across to you right now the idea of naturalness in performing tricks, I feel that I will have accomplished a wonderful thing. If you attempt to put any bit of Magic over with stiff hands, for instance in palming a coin, it would take but a minute for your audience to expose your secret. Your audience will know

at once that you have something concealed in your hand if it is held in an unnatural position. Their attention will be drawn to the hand because of its awkward pose;

whereas, if you hold it naturally, they will not even look at the hand.

You cannot hope to mystify your audience if you don't remember this:

Your Hands Must Be Held in a Natural Position

The amateur who tries to do tricks without scientific instruction always holds his hands very stiff and finds that his secret is discovered before he is half through with the trick.

You must study your hands before your mirror. Watch the natural poses of them in different positions. Practice with NATURALNESS always in mind.

Most of your ability to mystify depends on Naturalness in the poses of your hands. Hundreds of tricks depend on Naturalness for their effect. So master it at the very beginning.

* * *

PRACTICE EVERY DAY --

I have told you that most of the tricks are very simple. So they are. Some you can start using after perhaps only 15 minutes of practice.

But there are other tricks which you must study and practice for a few days before using them. It is only the amateur who will perform a trick before he is sure of it and can perform it in a finished manner. You must not allow yourself to perform like an amateur.

You know that "practice makes perfect" in everything. Practice your fundamental moves and practice your tricks until you are confident that you can put them across in professional style. Then perform your trick and you will have your audience talking about your remarkable ability.

Designate a certain period of time each day for your practice and stick to it as closely as if you were really attending a class at that time. Go off by yourself and concentrate on the lesson.

Always practice before a mirror. Practicing without a mirror is about as effective as practicing blindfolded. It will do you no good. You must see yourself as your audience sees you.

Your mirror will show you whether you are doing a move incorrectly and in a way that will give the trick away. You can see your errors immediately and can

(1-10)

correct them immediately before you form a habit of doing the move wrong.

Do not look at your hands. Always watch your hands in the mirror. Never look at them directly. If you watch your hands when performing, your audience will watch them and you will not get your effect. If you look at your hands while practicing, you will form the habit of looking at them – a habit which you cannot have if you are to be a real Magician. So train yourself right from the beginning not to watch your hands.

Each day when you practice, pretend you are before your audience. This will make you do your moves in the best possible manner.

PATTER IS IMPORTANT --

"Patter" is an essential part of each trick. By "patter" I mean the line of talk given by the magician to his audience while performing a trick.

I give you the patter I would use, but I want you to change it or add to it to suit your own personality. Remember, too, that patter must be varied to fit the occasion. You cannot say in a parlor what you would say on the stage. A joke that would be a big laugh in a parlor would fall flat on the stage.

Every time you practice your trick, use the patter with each move as I have indicated it in each lesson. In this way the patter will become a part of the trick in your mind, and you will keep up a running fire of talk without hesitating or laboring over it as if it were a memorized speech.

Sometimes the whole effect of the trick depends on the patter. The attention of the audience is diverted from what you are doing to what you are saying, and so you are able to get your effect.

You will find great enjoyment in making up patter for yourself. As you practice clever things to say will come to you and you will have a wonderful line before long. You can make your reputation on a clever line of patter.

BE SURE OF YOUR TRICK --

You must expect to find someone in every audience who will try to belittle your ability as an entertainer and magician. If you are not sure of yourself, such a person can make your performance a farce. He may expose your secrets and make you a failure as a Magician.

Let no move of any trick remain unmastered. The less mystery there is to you in a trick -- the more mystery it will have for the audience.

BE SURE THAT YOU CAN DO YOUR TRICK before demonstrating it. With practice will come self confidence,

ease of performance, and unquestionable ability to put it across.

NEVER REPEAT A TRICK AT SAME PERFORMANCE --

Something you must adhere to absolutely is never to perform the same trick twice to the same audience during the same performance. When you have them mystified, leave them mystified. Don't lift the illusion. Don't break your effect by repeating the trick. What your audience has missed the first time, they will watch for the second time, and so may discover your secret. And then, of course, you have lost your hold on them.

So remember, never repeat the same trick by the same method during the same performance.

* * *

Principle:

ANGLE OF VISIBILITY

This principle plays one of the most important parts in Magic. You must know how much the audience can see when you are in front of them or when they surround you. By practicing before a large mirror, you will learn the various angles of visibility in relation to where you are standing in your performance.

You must study these angles so that you will be able to judge how your hands should be held to conceal things.

We will use "palming a coin" for illustration, as you will learn how to finger palm a coin in the first lesson. This is to teach you the Angles of Visibility, not how to palm a coin. I want you to learn the principle in this ease, not the move.

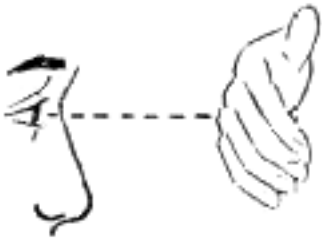
Hold your hand a few inches away from you at about the height of your waistline. Do not decide on a certain place you are going to hold your hand and then hold it there stiffly, but just let it take a natural position in front of you and that will be right.

Practice with both hands as you must become equally proficient with each.

Now comes the study of at what angle, in relation to where they are sitting or standing, your audience can see what you are doing.

Here are the three basic positions:

1--When your audience is directly in front of you:



Your hand concealing the coin must be held before you with the back of the hand toward your audience and your thumb up. Shake your hand from the wrist at your side until it is relaxed. Then hold it up before you in this position naturally. You will find that your fingers are slightly curved and are fairly close together. When your hand is in this position, the line of vision of the audience strikes the back of it.

2--When your audience is seated so that they can see down into your hand, as in the balcony; or when you have a small audience of two or three very close to you, so that they can look right down on your hand.

Shake your hand again to get it relaxed and take Position 1. Now tilt your hand from this position, thumb end toward you, so that you can see the back of your hand at an angle, with your little finger farthest away from you.

With this position of the hand, the line of vision of the audience looking down strikes the back of your hand.

3--When your audience is below you and you are on a raised platform, so that they can look up into your hand. Or, if they are seated at close range and you are standing so that they look right up under your hand.

Shake your hand again and take Position 1 naturally. Tilt your hand in the reverse direction from Position 2 --so that you can see the palm of your hand at a slant and your little finger is nearest to you. The line of vision upward of the audience will strike the back of your hand in this position.

Remember to practice with both hands, standing in different positions before the mirror. Relax your hands before taking each position so that you will hold them naturally.

When people are very near you, this Angle of Visibility is very important. You must study with the aid of your mirror the amount of slant your hands require in relation to the different places where these people are sitting or standing.

* * *

TRICK NO. 1

THE DISSOLVING COIN

This is one of the most mystifying of coin tricks. You will be able to do it after practicing it just a few times. You can do this trick at any time - at the dinner table, in a business office, or before an audience.

EFFECT:

Magician borrows a half dollar from someone in the audience and asks the loaner to mark it so that he will be able to identify it later. Then the magician borrows a handkerchief and places the coin in the center of it. The loaner is given a glass of water to hold in his left hand and the coin and handkerchief in his right hand. At a given signal he is told to drop the coin into the glass of water and then to remove the handkerchief. To his great surprise he finds the coin has disappeared. Then the performer nonchalantly takes the marked half dollar out of his purse, which has been in his pocket during the entire trick.

PARAPHERNALIA:

We are giving you FREE with this lesson the paraphernalia for performing this trick:

- 1--Glass Disk with polished edges, the size of a half dollar.
- 2--Glass with bottom the size of Glass Disk. The other articles you will need are:
 - a--An ordinary small purse with clasp at top.
 - b--A borrowed half dollar.
 - c--A borrowed handkerchief.

* * *

SECRET AND PATTERN:

Fundamental: Finger Palming

In your left hand trouser pocket you have the small purse and glass disk concealed.



Very casually while you are talking, get the glass disk (G) into your left hand, holding it at the base of the second and third fingers and curving your fingers a little over the disk. This is called Finger Palming.

NOTE: The "patter" for all tricks will be underscored and shown in quotation marks (" ").

"Now for this little experiment -- you know all tricks are experiments; sometimes they fail (sometimes) -- I must have a half dollar. I thought I had one here in my pocket but I believe I will have to borrow one."



You will find that you can work very close to your audience without their suspecting that you have something in your hand. Remember to practice with the "Angle of Visibility" in mind.

"Will someone please loan me a half dollar for a few moments? Put a good heavy mark on it -- any mark will do. Your girl's 'phone number would be great. I could then call her up in the morning."



This shows your hand as it looks to the audience. They do not suspect that you have the disk (G) concealed in it. Remember, naturalness in the pose of the hand which has the coin finger palmed.

"Or you might put my income tax on it. Any place on the coin is room enough for a zero."



You take the borrowed coin (H) with your right hand and place it in the left, holding it with the tips of the fingers and thumb of the left hand.

"Now if someone will loan me a pocket handkerchief...."



"I will cover the coin--"

Cover your left hand with the handkerchief, holding the Coin (H) with your fingers and thumb and the Glass Disk (G) palmed at the base of your second and third fingers.

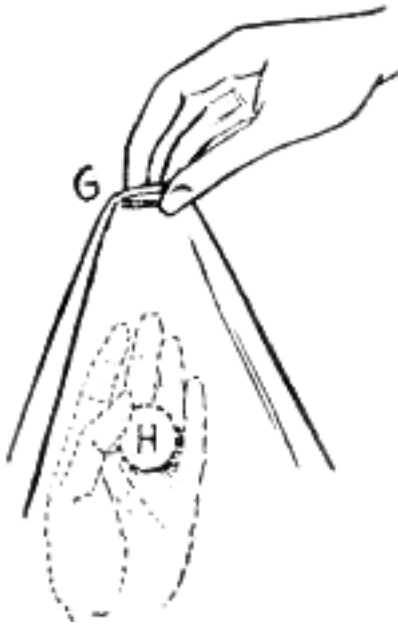
Move the Coin (H) down to your palm on a level with Disk (G) by crooking your first finger and thumb -- in preparation for its replacing the Disk (G).



"This would be a good trick to do in the City Hall where a lot of good coin tricks are done under cover each day."

Have someone fill the glass with water and ask the audience to examine it carefully to see that it is an ordinary glass.

Now, pretending to take the Coin (H), covered by the handkerchief, with your right hand, you take the Disk (G) and finger palm the Coin (H) in place of it by moving the coin into place with left thumb.



"Has the glass been examined carefully?"

You now have the Disk (G) under the handkerchief, which is held with the right hand, and the Coin (H) palmed at the base of the second and third fingers of your left hand.

Hold your left hand naturally until you are ready to dispose of the coin. Give the handkerchief to the loaner of the coin so he can hold the glass disc by its edge.



"The coin is now in the handkerchief and I would like to have you hold it over this glass of water."

Of course the coin is not really in the handkerchief. That is simply part of your "patter." The coin is really in your left hand and the glass disc is under the handkerchief.

Loaner holds handkerchief over glass of water, glass hidden completely by handkerchief, as shown.



WARNING: BE CAREFUL AS TO LIGHT. If light comes from side, and handkerchief and disc is between spectator and light it is dangerous because light coming through handkerchief and glass disc shows that half dollar is not under handkerchief. Spectator should be between light and handkerchief. At the dinner table where the light falls from above it is ideal. Study this closely. If handkerchief seems rather thin it is safer

to double it so that disc is held under two thicknesses of cloth.



"When I count 3, drop the coin into the glass of water. 1-2-3!"

Spectator drops coin.

(1-15)



You now have your opportunity to put the coin in your purse with your left hand. Your purse is in your left hand trouser's pocket. Remove your hand as soon as possible and do not look at your left hand at any time.

"What a merry clinking sound -----."

Now, tell loaner to remove handkerchief.

"Now your coin must be in the bottom of the glass.---But it seems to have faded away like a first-class bank account in stormy weather."

Pour the water out of the glass. The Disk will stay in the bottom.



Produce marked coin from your purse.

"As I have saved something for a rainy day, I will share it with you. Here is your coin, which has been in my pocket all evening."



Another finish is to drop the coin into side pocket of loaner if you can do it, and produce it from there later. Do not try this unless you are sure you can do it without detection. Or you can produce coin from behind your knee, arm or from under vest, or if sitting at table from under table itself as though coin had gone through table.

To make this trick Fool-Proof. If someone tries to examine the glass after the trick is over, drop a half dollar into the glass and tap the glass a little. The half dollar and glass disk will come out together, sticking together because of the moisture from the water. The curious then can examine the glass and find nothing out of the ordinary about it. In the meantime, under pretense of wiping coin dry with handkerchief, you can put the disk into your pocket with handkerchief.



* * *

Lesson 2

Your next lesson comprises four puzzling effects of an impromptu nature:

1--You drop a burning cigarette into a borrowed-handkerchief. Smoke issues therefrom. Cigarette vanishes and handkerchief is not burned.

2--Lighted cigarette placed in bare left hand vanishes.

3--The center is burned out of a borrowed handkerchief and handkerchief quickly restored.

4--A strip of tissue paper tucked into the left hand suddenly vanishes and appears again in a mysterious fashion.

These tricks involve an ingenious piece of apparatus which we send you FREE. It can always be carried with you. You are then prepared to do these tricks anywhere and at any time.

You will also learn more about the principles of Magic and the presentation of tricks, which will be invaluable to you.

LESSON 2

THE HISTORY OF SLEIGHT OF HAND

Before proceeding with the lesson I want to give you some further history of Magic -- this time, on the branch of Magic called Sleight of Hand.

Sleight of Hand is the art of deceiving the eye of the spectator by adroit movements of the hand so as seemingly to bring about the following effects:

- 1--Producing--making an object appear
- 2--Vanishing--making an object disappear
- 3--Transforming--changing an object

Legerdemain and prestidigitation are synonyms of the term, sleight of hand.

The term, legerdemain, is often used to cover all kinds of conjuring by means of mechanical and other contrivances, but properly applies only to tricks performed with the hand. In analyzing the word we find that it is derived from the French "leger de main," which means nimbleness of hand, or literally, "light of hand" -- "the light touch."

The word, prestidigitation, also applies to tricks depending on the hand only for execution. This word has a Latin origin and analysed means quickness of the fingers.

Two Divisions of Magic

Even in ancient times there were two distinct branches of Magic -- that of Divination and Necromancy, communication with the spirit world; and that of Jugglery and Sleight of Hand. The latter branch had no significance in the destinies of people, as the former did, but was regarded only as an entertaining art. The sleight of hand artist, however, was believed to have supernatural powers which gave him his skill.

Ancient vs. Modern Magic

Judging from the accounts which history has preserved for us of the marvels performed by the magicians of antiquity, it is evident that these men were very skillful in practicing their art. It cannot be said, however, that the ancients were more proficient in their art than modern magicians are. Robert Houdin, the greatest of the early modern conjurers, has said, "Antiquity was the cradle of magic -- but only because the art was yet in its infancy."

The explanation then, for the seemingly greater miracles that were produced in ancient times, is that people believed in the supernatural powers of the magicians. The effects these magicians produced were believed to come from inspiration from higher or lower powers and thus took on a tremendous significance for the people. The effects assumed the proportions of miracles in their minds.

Today, these effects, while still mystifying and startling, are not regarded as produced by gods or demons. Thus

has arisen the idea that something of the art of conjuring has been lost. Nothing, however, has been lost and very much has been gained in the art of sleight of hand. It is merely that the attitude of people has changed with the enlightenment of modern civilization regarding the supernatural, and now they regard Magic as an Art -- and the most entertaining of all Arts.

The Romans Versed in Conjuring

Conjuring exhibitions date way back to the Roman Empire, showing that even then the art was regarded as one for entertainment. The favorite feat at these regular events was that of the "cups and balls." The cups were called by the Latin word, acetabula, and the performers were called acetabularii. Records show that the balls that were used were round white pebbles instead of the light cork balls used today by conjurers. This, it seems, must have made the performance of the trick a great deal more difficult.

Sleight of Hand in the Middle Ages

The Fall of the Roman Empire in 476 A. D. marks the beginning of the Middle or Dark Ages, which ended with the revival of learning in the Fifteenth Century. These centuries of ignorance naturally were the time for the flourishing of the Black Art. Magic in all its phases and sleight of hand had a widespread influence in the lives of the people.

Forerunners of the Modern School

Emerging from the Dark Ages, we find that the earliest exponents of the modern school were Italians. The foremost were Jonas, Androletti, and Antonio Carlotti. We know little about them and their art however, as the secrets of legerdemain were jealously guarded.

In 1793 we get the first written word on sleight of hand. A book entitled "Testament de Jerome Sharpe, Professor de Physique Amusante," was printed in Paris. The author, M. Decremps, gives an account of some of the methods then in vogue.

In 1840 Döbler, a German physicist, devised an entertainment which is the beginning of the whole modern development of the art of sleight of hand. This was, in effect, the same as the conjuring entertainments which have since become so popular and familiar to everyone.

The names of the most eminent conjurers of a more recent school of magic should be familiar to you. They are Wiljalba Frikell, Hermann, Bautier de Kolta, and J. E. Robert-Houdin.

Modern School of Legerdemain

Robert-Houdin, a Frenchman, is regarded as the actual founder of the modern school of legerdemain. This celebrated conjurer, originally a watchmaker and mechanic, was an

inventive genius. When he was young, he turned his attention to legerdemain and bent all his energies to the development and improvement of the art. He discarded the clumsy tricks of what he called the "false-bottomed school" and the gaudy paraphernalia with which his predecessors encumbered their stages.

He produced in 1845 a number of entirely new illusions at a little theater in the Palais Royal, combining the resources of mechanical and electrical science with dexterity of the hands and effective presentation.

His entertainments were a great sensation in Paris and placed Robert-Houdin at once at the head of his profession. His skill and success were so great that the French government sent him on a roving expedition to Algeria. The purpose of this was to have him destroy, by his exhibitions of natural magic, the influence of the "marabouts"—wonder-workers who had gained a dangerous power over the Arabs by their pretended miracles.

A little later on we will begin the study of actual sleight of hand. The tricks and moves you are learning now, begin to give you some manual dexterity, that is, skill in the use of your hands. These tricks do not depend entirely on this dexterity but are the foundation for the more difficult aspect of Magic, the art of sleight of hand.

This art requires practice and study. Robert-Houdin sums it up in this way:

"To succeed as a conjurer, three things are essential; first, dexterity; second, dexterity; and third, dexterity."

This is not a mere trick of language—the hand must be trained, the eye must be trained, and the tongue must be trained.

* * *

LESSON 2

I know you must be enthusiastic over the first trick I gave you and are eager to begin on your second lesson.

I want you to go back to the first lesson from time to time and read it over carefully. Each time you study it and each time you practice the trick, the moves become more firmly fixed in your mind. Remember that to be clever at Magic you must know your tricks so well that the moves become automatic.

I gave you a great deal of the fundamentals of Magic in Lesson 1—foundation principles which apply throughout the course. To summarize, these are:

- 1—Angle of Visibility.
- 2—Naturalness in Performing.
- 3—Simplicity of Tricks.
- 4—Importance of Principles in Magic.
- 5—Importance of Patter.
- 6—Finger Palming.

(2-3)

An understanding of these must become a part of you as you will use them time and again in performing many, many tricks. Keep on practicing. Keep on studying. You will be gratified to find how fast you progress. Always with each new lesson you get, spend some time in reviewing the preceding lesson first. The new lesson may call for use of a principle in a preceding lesson in addition to the new fundamentals I give you, and you must have it well in hand.

POWER OF SUGGESTION

Today I want to give you some of the psychology of Magic so that you may have a better understanding of your powers as a Magician and just what it is in the human mind that gives you this power.

The Power of Suggestion is a tremendous force in life. Whether you have realized it or not, it has had its influence on you many times, and you are constantly using it on other people. It has a two-fold character. It works on you from within and it works outward from you on the people with whom you come in contact. Let me explain:

The Power of Suggestion as It Works on Yourself

This is nothing but the theory on which Coue, the French druggist, based his slogan, "Day by Day in Every Way I Am Getting Better and Better." You know what a sensation he caused everywhere. People flocked to see him. He was hailed as a healer. Thousands became mad devotees of the Coue fad. And why? Because he was a psychologist.

Coue merely gave the people the slogan and told them that if they said it over and over again it would make them actually feel better. And it did what Coue said it would do—not because saying a few words can make a sick man well—but because the Power of Suggestion is so great that if we suggest to ourselves often enough that we are getting better and create a vision of ourselves as well and strong, before long the mind has controlled the body to the extent that its functions are toned up. The result is that we do actually feel better.

Coue's influence started with a small group. The gripping stories of the healings were spread far and wide by the newspapers and by the people themselves. And here we find the Power of Suggestion working again. Others who read or heard the tales received the suggestion within themselves that Coueism would make them get better and better, and so Coueism spread like wild fire into every corner of the globe. And back of it is nothing but the Power of Suggestion.

Now why have I gone into the discussion of the Power of Suggestion from a medical viewpoint and in a way that hints of Christian Science? It is because I believe that the Power of Suggestion in medicine is the strongest example I can give you of how this power works within all of us.

Examples from Medical Science give you an understanding of how great this power is. But its influence in the medical field is only a small part of its wide scope. It works con-

stantly in every day life, in the business world, in the professional world—in every walk of life and with people of every age.

Actors are an outstanding example of people who must exercise this power over themselves. Al Jolson, for instance, must be under the influence of suggestion to the extent that he believes, not that he is made up with cork, but that he really has a dusky skin and is singing for his Mammy. If he felt that he were only acting a part, he would never be the success he is.

You have exercised Suggestion on yourself many times. In your business you have suggested to yourself that you were going to sell that Jones firm. You saw the order already written and signed, and you began to believe you were already shaking hands with R. A. Jones, Sr., as your customer. You believed it and you went after Jones with a bang and sold him. That's the way the Power of Suggestion will work for you. It sells you the ideas first, and you must be sold before you can sell the next fellow.

THE POWER THAT SUGGESTION HAS OVER YOU IN MAGIC

You wonder how this applies to you in learning Magic. In just this way: Tell yourself from the start that you are going to be a Real Magician. Form a picture in your mind of yourself as a Successful Magician on the stage or see yourself as Popular, Well Known, a Social Success through your knowledge of Magic. Form a definite image of what Magic will do for you. The Power of Suggestion will do the rest.

If you are in earnest and have suggested to yourself that you are going to be a Social Success or a Stage Success, you will find that "Day by Day in Every Way You Are Getting Nearer and Nearer Your Goal."

Don't minimize the value of this suggestion. The positive suggestion—YOU CAN--will actually give you greater ability because your mind will be open to learn and will be eager to learn.

Another phase of this wonderful Power over you is the use of it when you are performing before your audience. Enter heart and soul into the part you are playing. Your audience believes you have marvelous powers. Let this Suggestion coming from them exercise its power over your mind and let it make you believe that you have these powers. For instance, your audience really believes that you make the coin disappear somehow in Lesson 1 and that you must be in conspiracy with the spirits in Lesson 2 to make the burning cigarette vanish. Talk yourself into believing that you actually do this. Before long you will have yourself almost believing that you do vanish the coin and the cigarette. At first, this may sound impossible to you. But try it.

You will find that with the suggested belief that you are doing magical things, you will get greater confidence and better presentation of your tricks. This belief will show in your facial expression, which is an important element in putting your tricks across. When the handkerchief is whisked

off the glass and the half dollar is found to be "dissolved," you show a surprised expression just like the audience.

All of this makes for a belief in yourself as a Real Magician. I want you to realize this mighty tool you have in yourself for making yourself what you want to be—this tool of the Power of Suggestion.

YOU PUT YOUR AUDIENCE UNDER ITS INFLUENCE

This is the other aspect of the Power of Suggestion—that coming from you to your audience. Now then, how do the things that you are constantly suggesting in your tricks work on them?

Let us take the first trick and analyze it from this standpoint. This will give you a new angle from which to study Lesson 1 and all succeeding lessons.

You will begin to understand the great power you have in Magic and what mysterious thing gives you this power.

Take your first trick, The Dissolving Coin, before you as I have it here before me.

Look at your first paragraph of patter. You have put your hand in your pocket to get the glass disk. But you say, "I must have a half dollar. I thought I had one here in my pocket," etc. You have suggested to the audience that you put your hand in your pocket to get a half dollar. It would never occur to them that you might have taken something else from your pocket because you suggested to them that you went for a half dollar and found you did not have it. There is a bit of the working of the Power of Suggestion.

Now go on to the next paragraph of patter. You tell the spectator to put a good heavy mark on the coin—any kind of mark. This suggests to the spectator that he will be able to identify the coin because, he reasons, you cannot very well have a duplicate coin marked just as he marked his coin.

Then as you go along, you add little touches of humor to get the good will of the audience. This makes them more receptive to your suggestions.

During the rest of the trick up to the whisking off of the handkerchief, it never occurs to the spectator that he hasn't the coin under the handkerchief because you have constantly suggested that he has it—by saying that the coin is under the handkerchief and by telling him to drop it. He hears it hit the bottom. This constant suggestion produces the result that the spectator believes that he has the coin without questioning it at all. You may be sure that he believes this—such is the Power of Suggestion. Then imagine his astonishment to find when the handkerchief is removed that the coin has "dissolved." He knew he dropped the coin into that glass of water and what in the world happened to it?

What has been one of the main elements, then, in producing your effect? The Power of Suggestion, which led the spectator to believe absolutely without question that things were what they seemed because you suggested to him that they were.

LESSON 2

In this lesson I teach you four clever effects in which you utilize the Thumb Tip. Each trick can be worked at a moment's notice, and each effect is startling and very puzzling.

Basically, these four effects are one trick, dependent on one working principle and the use of the Thumb Tip. I give you the four effects to show you the value of a principle. Many, many tricks are based on this one principle of the Thumb Tip, "Vanish" and "Production." You may be able to originate other good effects and variations after you have mastered this lesson.

I do not advise your giving all four of these effects at one performance. Though there is no serious objection to performing one after another of these tricks, it is best to do only one or two tricks based on a certain mode of working at one performance.

Any one of these effects can be performed at the dinner table, at your club, in the parlor of a friend whom you are visiting, or on the stage.

* * *

MYSTERY OF THE BURNING CIGARETTE

EFFECT:

Magician borrows a handkerchief and lays it over his left hand, fist closed and thumb side up. He shows his right hand empty and with his right thumb tucks handkerchief a short way into his left fist. He next borrows a piece of lighted cigarette and drops it burning end down into the little well he made in the handkerchief with his right thumb. The smoke curls upward from the handkerchief. The audience holds its breath, thinking that the handkerchief is being burned. The Magician then sprinkles the magic "woofle dust" over the handkerchief and pulls it off his hand. The handkerchief is undamaged and the cigarette has vanished.

PARAPHERNALIA:

You have been given FREE the paraphernalia for performing this trick:

1--The Thumb Tip.

The other articles you will need are:

a--A borrowed handkerchief (man's or woman's).

b--A borrowed burning cigarette (not over half a cigarette in length).

THE THUMB TIP:

This week I introduce you to a clever piece of apparatus which you can use in performing many tricks. I sent it to you FREE with your steel box and other apparatus when you enrolled. No doubt you have been wondering just what it was for. It is called the THUMB TIP. It is a piece of metal shaped like the first joint of the thumb and painted flesh color.



The Tip is made to slip on the end of your thumb, but does not fit down tight. There is a space between your thumb and the end of the Tip to permit the concealing of a small object, such as a piece of cigarette, a strip of tissue paper, a piece of cloth, etc.



Now stand before your mirror. Put the Thumb Tip on your thumb. Hold your thumb sideways and you will see that the Tip on your thumb is noticeable. To keep the Tip concealed when the hand is in this position, hold your thumb naturally behind your four fingers.



Point your thumb towards the mirror and you will get the effect that your audience gets in looking directly at your hand. The Tip cannot be seen and your thumb looks natural. In this position the hand can be shown empty to the audience and they will never suspect that they are looking right at the apparatus.

A little farther on in this lesson I teach you Thumb Tip Manipulation, the methods of keeping the Tip concealed in other positions of the hand.

A WORD OF CAUTION:

The Thumb Tip becomes shiny when it is carried in the pocket for some time. Some shine is all right, but too much spoils the effect of natural skin.

To avoid this, paint the Tip occasionally with Japan paint (this dries quickly). Many paint stores sell this paint in small tubes or you can purchase it directly from me in exactly the correct shade. The paint can be thinned with turpentine, benzine, or gasoline. Sometimes rubbing tip with a cloth dipped in one of the three dulls the surface.

SECRET AND PATTERN:

"I would like to borrow a handkerchief for a moment—any kind, any shape, any size, any nationality. Thank you. This one will answer the purpose nicely."

Now while someone is giving you a handkerchief:

Have the Thumb Tip with the nail side nearest your body ready in your lower righthand vest pocket. Put your right hand in your pocket and slip the Tip on your right thumb.



Take handkerchief from spectator with left hand and transfer it to the right hand. By using left hand to take handkerchief, it keeps thumb tip on the right hand from being exposed. Open up handkerchief and hold by two corners. The handkerchief and the fingers of right hand screen the thumb tip.



Casually without saying anything, show left hand empty and spread handkerchief over it with right hand.

Show right hand with end of thumb to audience. This exposes the whole inside of hand. Seeing nothing concealed, the audience takes it for granted that performer is not palming or hiding anything.

And right here, let me give you a big point in Magic that you must never forget.

SHOW YOUR HANDS EMPTY AT VARIOUS TIMES BUT DO NOT CALL ATTENTION TO THE FACT. MAKE IT A NATURAL MOVEMENT. The audience can see for themselves that nothing is concealed in hand. DO NOT SAY IN WORDS, "MY HANDS ARE EMPTY." The suggestion of showing the hands is enough. An ounce of DEMONSTRATION is worth a pound of talk.

"I spread the handkerchief over my left hand and make a little well in it, so--."



Now swing right hand over towards handkerchief, the four fingers hiding the thumb tip. Push right thumb into handkerchief and left hand which has closed around tip. When tip is well concealed raise fingers of right hand high in air. This shows audience that well is being made with the right thumb. Draw thumb out (but leave thumb tip in handkerchief) and push back again. This extra tucking is done for a psychological reason. When thumb is drawn out, it shows a natural thumb, and the second tucking with a natural thumb leads people to think that the first was made in exactly the same way.

"Next I want to borrow a lighted cigarette, or rather a piece of one."

(If someone is smoking, ask for that particular cigarette. If not, ask to have one lighted. In case of emergency, have a cigarette of your own with you. After cigarette is lighted, have spectator break cigarette in half and give you lighted part.)

"That's it-give me the front half, light and all."

(Take piece of cigarette between thumb and forefinger of right hand.)

"Now watch. I'll just drop this burning cigarette into the handkerchief, burning end down."



You show well in handkerchief and drop cigarette slowly into the handkerchief. Much depends upon the fact that you CONVINCE audience that you have actually dropped the cigarette into the handkerchief. Show right hand open towards audience with fingers wide apart after cigarette has been dropped.



"Yes, there it is smoking away peacefully."

Audience can see smoke curling up from the handkerchief.

"There is a way that chemists condense smoke. They squeeze it together this way."



Push right thumb into well and into thumb tip. This shuts off air, which immediately puts the fire in cigarette out.



Bring hand away with thumb tip on right thumb, casually showing hand again to audience, and of thumb facing them.



"Sometimes I weight it down with a little Magic "Woofle Dust."



Reach into vest pocket, apparently to get a pinch of "woof le dust," but in reality to leave thumb tip there. Leave thumb tip in vest pocket. Pretend to sprinkle dust into handkerchief. Then take handkerchief by one corner and pull slowly off of left hand, so that audience can see that cigarette has disappeared and handkerchief is undamaged. Hold handkerchief again by two corners, one in each hand.

"Yes, it's magic woofle dust. It not only condenses the smoke, but it dissolves the cigarette and is a wonderful restorative for a burned handkerchief."

Return the handkerchief to the loaner.

* * *

THE ASBESTOS PALM

EFFECT:

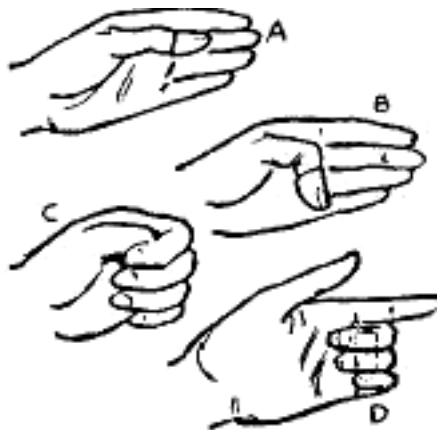
This is a similar effect to the above, but no handkerchief is used. A lighted cigarette is dropped into the left hand, and a little Magic Sand is sprinkled

on it. The left hand is opened slowly—and the cigarette has vanished.

(2-10)

THUMB TIP MANIPULATION:

This effect involves a little manipulation which you must learn right now. It is a little sleight of hand. You show your hand apparently empty and yet conceal a thumb tip. These manipulations enable you to show thumb freely at times. You will find that it is little moves like these that help to make the MASTER MAGICIAN.



Get thumb tip on your left thumb. Now study carefully illustrations at left. Hold thumb in Position A. Bend thumb to Position B. Close fingers around tip, Position C. Partially open hand, Position D, leaving thumb tip inside middle, ring and little fingers of left hand. The three fingers conceal the thumb tip in such a way that hand can be shown carelessly and the tip will not be seen.

Reverse the movements and get tip on thumb again. Practice until you can do these moves EASILY and QUICKLY with either hand.

SECRET:

Have tip in left pocket. Get tip onto left thumb and conceal as in Position A above.

Borrow a piece of lighted cigarette as in effect described before.

Manipulate thumb tip to Position D. Casually show left hand. Hold the cigarette with thumb and forefinger of right hand.

Get tip onto thumb again—Position A. Bring thumb up and point hand towards audience, end of thumb foremost. This convinces audience that hand is empty.

Close hand quickly, bending thumb and getting tip to Position D again. Withdraw thumb. To audience it looks as though empty hand was closed.



Drop cigarette into left hand, tucking it in with right thumb. This puts fire of cigarette out and allows you to remove tip on right thumb.

Show right hand empty, tip of thumb pointed toward audience. Reach into vest pocket for the Magic Sand, leaving tip in pocket. Sprinkle imaginary sand over left hand.

Open left hand slowly—the cigarette has vanished.

Study the first effect, MYSTERY OF THE BURNING CIGARETTE, and model your presentation of this second effect upon that, using the same patter where appropriate.

BURNING A BORROWED HANDKERCHIEF

EFFECT:

Performer borrows a handkerchief (man's or woman's). He sets fire to the center of it by holding it over a lighted candle or match. The flames are extinguished and handkerchief is touched with a magic ring. The handkerchief is restored.

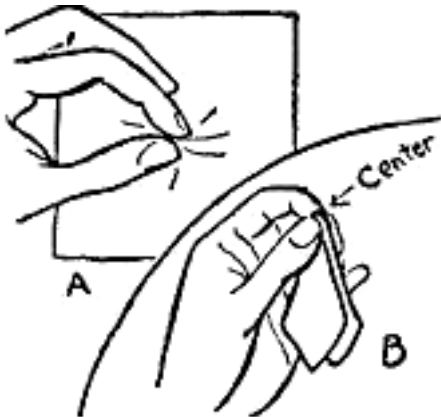
This trick goes well at a moment's notice in the parlor, the dining room, at a banquet, or on the stage. Many times I just happen to see a handkerchief in a lady's lap. I ask her for permission to use it and proceed to do the trick as though seeing the handkerchief gave me the idea of doing it.

PARAPHERNALIA:

- 1--The Thumb Tip.
- 2--A borrowed handkerchief.
- 3--A piece of white cloth about 4 inches square, similar to cloth used in a handkerchief.
- 4--A small box of matches or lighted candle.
- 5--A small nickel-plated ring or a finger ring.

SECRET AND PATTERN:

Take small square of cloth, pick up by center and allow edges to fall downward. Note A and B in illustration.



Then tuck into the thumb tip--center of cloth going in last. Center of cloth should rest on side of tip so that thumb can easily be placed on it. This is done so that when thumb is withdrawn from tip the cloth is also drawn out.

Arranged in this way, tip and cloth can be left in right-hand pocket until needed.

Place tip on right thumb, drop hand to side, thumb away from audience, and you are ready to start the trick.

If at a banquet or in a parlor you notice that a lady happens to have a handkerchief in her lap, say:

"I beg your pardon, but I just happened to notice your handkerchief and the kind of cloth it is made of. It is very seldom that one sees that cloth."

Or if you have to borrow a handkerchief, say something like this, while taking it with left hand:

"I would like to borrow a handkerchief for a few moments as I have in mind an experiment that has always been interesting. Thank you. That is just the kind." (Then happen to notice something peculiar about handkerchief.) "Well, here's something peculiar." (Feel it.) "Here is a peculiar cloth which we see very little of."

In either case, open up handkerchief and hold by two corners, the tip being concealed behind handkerchief. This position shows palms of hands empty.



Now pick up center of handkerchief with left hand and transfer to the right hand so that thumb of right hand with tip comes behind handkerchief and index finger in front. Again palm of right hand can be shown. You have thus convinced your audience that you hold nothing but the handkerchief.



Draw handkerchief up through left hand, stopping at a point shown in this illustration.



The left hand closes around the handkerchief and thumb tip, holding both securely. Leave thumb tip with false handkerchief center, in left hand. As right thumb leaves tip, it pulls up with it the little false center (piece of cloth) from the tip. If cloth does not come up with movement, do not worry. Simply pull it up with thumb and first finger. It will look as if you are pulling up handkerchief.



The effect to the audience is that the handkerchief was merely drawn partially through the hand, that the central portion sticks out above and the corners and outer part hangs below, while in reality it is the false or extra center that you have pulled up out of the thumb tip and not the borrowed handkerchief.



"This is peculiar cloth because it is fireproof. A moderate flame will not burn it."

Reach over and allow light of candle to set fire to false center (piece of cloth), which audience thinks is center of borrowed handkerchief.

If a lighted candle is not handy, have someone light a match for you.

"It does burn after all. I must have been mistaken in the cloth. (To owner.) You will pardon me, I am sure."

After cloth has burned a bit and audience has been led to believe that a fair size hole has been burned in handkerchief,

(2-13)

pinch out flame with right index finger and thumb or blow out flame. Then tuck burned part into tip with right thumb and draw tip away on right thumb. Point end of thumb toward audience, showing hand empty, and reach into right vest pocket, leaving tip there. At the same time say:

"In my pocket I have a ring." (Take ring from pocket.) A Magic Ring. If I drop it on the handkerchief, it sometimes helps me out of an embarrassing difficulty." (Place ring on top of left hand.) "The hole in the handkerchief and hole in the ring makes a sort of affinity or friendly feeling between the two."

Take ring in right hand. Grasp handkerchief at bottom and pull it out of left hand through the ring. Hold up by two corners to show handkerchief is as good as ever.

"See--just as I told you. The center is again in the middle and I thank the lady (or gentleman) for the loan of her (or his) handkerchief." (Return handkerchief.)

"And remember, that a flame on a candle (or match) is worth two in a handkerchief."

THE ENCHANTED PAPER

This trick is based on the same principle as the preceding effects and may be performed at any time. It is a good one to have at your command when the use of a cigarette would not be in good form.

EFFECT:

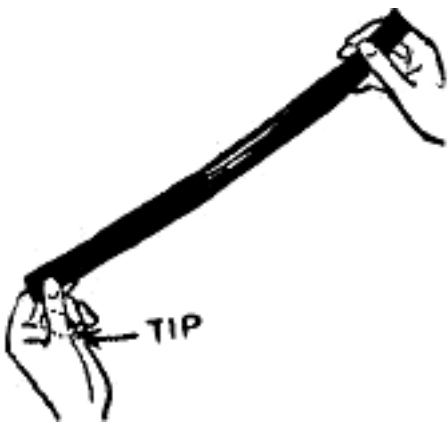
A strip of colored tissue paper is shown and tucked into the empty left hand. Upon opening hand, paper has disappeared. Performer states that it has not disappeared and is still on his hand, but it is visible only to the eye of a medium. He places imaginary ball of paper on spectator's upturned palm. Magician then borrows a handkerchief and spreads it over his left hand. With the empty right hand he makes a little well in handkerchief, pushing it a bit into the closed left fist. He then takes imaginary ball from spectator's hand and drops it into the well in the handkerchief. He reaches down and pulls out the strip of tissue paper.

PARAPHERNALIA:

1--The Thumb Tip.

2--A strip of colored tissue paper about 20 inches long and one inch wide.

3--A borrowed handkerchief.



SECRET AND PATTERN:

Have thumb tip in left pocket. Just before starting this experiment, get thumb tip onto left thumb. From pocket or off of table, take a strip of tissue paper. Casually show both hands and strip of paper. As in the preceding effects, end of thumb holding tip, is held toward audience. Then finger palm thumb tip, as explained in Thumb Tip Manipulation, and show tissue paper as in illustration.

"This is an old Chinese experiment based on an ancient teaching that everything is, even if it isn't. I can best illustrate it with this strip of colored paper. To the ordinary eye there is nothing mysterious about this paper—but to the trained eye of the psychic there is more than you have dreamed."

"To begin with let me tuck this strip of paper into my left hand."



Now slowly tuck strip of paper into left hand with the right index finger. You are really pushing the paper into the thumb tip. For the last two tucks, use the right thumb and carry thumb tip away on thumb.

Casually show right hand empty and then slowly open left hand and turn palm upwards.

"Yes, there it rests on the palm of my hand. What's that? You cannot see it? Oh, I forgot, you are not using your psychic eyes. When I placed the paper in my closed hand, the warmth of the hand caused the paper to return to its astral form—the state where a thing is, but seemingly isn't."

You turn to a gentleman nearby.

"Pardon me, sir, but you seem to have a psychic eye. Would you mind holding the paper for me? Thank you. Just hold out your left hand palm upward."

You now pretend to drop the imaginary ball of paper from your left hand into spectator's hand. Make movement as natural as though you were giving him a real ball of paper.

"Now, the paper is in your keeping. You can see it, can you not?"

If the gentleman goodnaturedly says Yes, then you say:

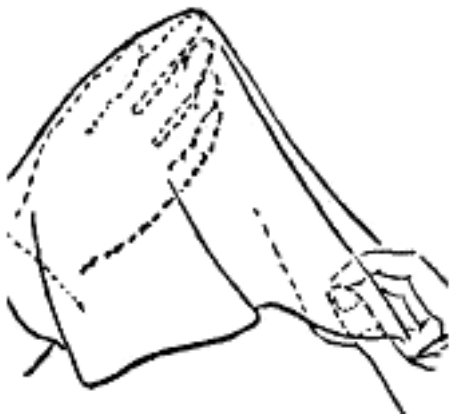
"There, didn't I tell you the gentleman was a psychic."

If the gentleman says No, then you say:

"You aren't looking very well today. Well—anyway do not drop the strip of paper."

Turn to the audience.

"I wish to borrow a handkerchief. Either a lady's or a gentleman's. That one will do nicely."



Take handkerchief with left hand. Hold handkerchief up by two corners, thumb tip concealed behind upper right hand corner of handkerchief. Allow handkerchief to drop from left hand and to be held by right. Show left hand, both sides, and spread handkerchief over it. Show right hand empty and tuck handkerchief into left fist with right thumb, leaving thumb tip gripped in left fist. The tissue paper is there ready to be produced, but to the audience the handkerchief is empty. Turn to spectator who holds imaginary paper.

"Now, sir, if you will please give me back the astral paper."

Pretend to pick the paper out of his hand with thumb and index finger of right hand and carry it over to the handkerchief and pretend to drop it into the well. In carrying imaginary paper across, keep palm exposed to audience and other fingers well up. Even though you say you have a paper in your hand, you must convince audience that you haven't.

"I use a handkerchief for this reason—the warmth created by cloth is different from the warmth of my hand. The former materializes objects, while the latter dematerializes them. In other words, one says it is, and the other says it isn't. Now you will observe that it is."



With thumb and forefinger of right hand get hold of one end of the tissue in the thumb tip and pull it out slowly. The forefinger and thumb of left hand should hold paper firmly enough to keep it from being pulled out too soon as a ball instead of a strip.

After paper has been pulled out, turn to spectator who held imaginary paper.

"There you are, sir. You can take it home as a souvenir, but be careful how you hold it or you may not have it."

HERE IS ANOTHER LITTLE MOVE WITH THE THUMB TIP THAT WILL COME IN HANDY AS IT MAKES A NATURAL GETAWAY WITH A COMEDY TOUCH. (By "get-away" I mean the disposing of an article.)



Handkerchief is on left hand and the tip is in the well in the handkerchief.

Bring right hand over to it, thumb near the well.



Throw handkerchief from left hand over onto the right, at the same time allowing thumb tip to come onto the right thumb. Illustration shows tip on thumb and handkerchief covering hand.



Call attention to handkerchief on flat hand. Raise forefinger. The thumb with tip goes into three fingers where tip is finger palmed.

Pretend to audience that you are going to make a production of some kind. Whisk handkerchief away and show forefinger upright. Then wiggle it a little. It has a funny effect. Try it. This is simply a stunt to change the thumb tip from one hand to the other or to vanish it altogether.



Return handkerchief to loaner with left hand and get rid of tip in pocket with the right. A simple ruse for disposing of Thumb Tip is to start to put handkerchief into right-hand coat pocket and then remember that handkerchief was borrowed and hand it back. The movement of putting it in pocket is enough for you to slip tip off of thumb and allow it to go into pocket.

Harlan Tarbell

TARBELL SYSTEM, INCORPORATED, Chicago.

* * *

LESSON 3

In your next lesson I give you three effects with rings -- each completely mystifying.

1--A nickeled ring, after being examined, is threaded on a string by a member of the audience. The string is held at both ends by spectators. Performer under cover of a handkerchief in a few seconds removes the ring.

2--Three cardboard rings, red, white, and blue in color, are examined and threaded on a string by the audience. The string is held at both ends as in previous effect by two spectators. Performer removes ring of any color called for without tearing it.

3--Performer ties a single knot in center of a string to make a ring. Then the two ends are tied. Spectator is asked to remove ring, but is unable to do so. Performer then removes it in a second.

Lesson 3 also will add a wealth of knowledge on Magic to that you have already learned.

NECROMANCY AND DIVINATION

I gave you in Lesson 2 some of the history of Sleight of Hand, one of the two distinct branches of magic.

The second division of the art includes Necromancy and Divination, which I shall tell you about here.

Necromancy

is the art of foretelling the future by pretending to have communication with the dead. The ghosts of the departed are called up to give oracles or discover hidden treasures; or these ghosts come, through the offices of the necromancers, to enter men's bodies and afflict them with diseases or cure them. The spells and incantations of the magicians are believed powerful enough to control the will even of such divinities as the gods who can drive the winds and give or withhold the rain.

These beliefs began in ancient times and have come down through the ages and are still prevalent. Today in civilized countries we have spiritualism, which illustrates the ability of the medium, like the necromancers of old, to call up the sprits of the dead to give oracles foretelling events. And among primitive peoples living now the belief that these ghosts can enter the human body and afflict or cure them is still a strong influence.

Among Wild Natives of Australia

The necromancers or sorcerers from ancient times to the present have wielded their tremendous power for both good and evil. History tells us of the complete belief of people in the influence of these sorcerers, and even today the wild natives of Australia live in mortal terror of sorcerers. They believe that sorcerers, armed with their mysterious power called "boyl-ya," ride through the sky, invisible except to other sorcerers. They enter the bodies of men and feed on them, not eating the bones, but consuming the flesh. The native feels pain as the "boyl-ya" enters his body like a bit of pointed quartz. Another sorcerer, then, can extract the evil with a piece of quartz in the supposed shape of the "boyl-ya."

The leg bone of a kangaroo can bewitch a man to death if a sorcerer points it at him while he sleeps, these primitive Australian tribesmen believe. And, indeed, many evil things can this sorcerer do to a man while he sleeps, according to them. The sorcerer can creep up to him and steal away his kidney fat, where they believe a man's power lies; or he can call in a demon to strike the man behind the neck with his club; or he can get a lock of hair and roast it with fat over the fire until its former owner pines away and dies.

The Australians, like other barbaric tribes, do not believe that a man can die of causes other than being slain

or being bewitched. When a native dies a natural death, it is believed that some hostile sorcerer caused it. This evil magician must be discovered by other forms of magic. This is how it is done. The corpse itself may seem to push its bearers in the direction of the murderer, or the flames of the grave-fire flicker towards where he is, or some insect is seen creeping towards his home. When the next of kin observe these magic signs, they must set off to take vengeance on the murderer.

The necromancer, however, may have kindly duties as well. He sits by a sick man and charms and charms until the stricken man recovers. He may pull the disease out of the body by means of a stone spear-head or a fish bone or may bring it out along a string. Thus the necromancer with his powers of good and evil is both respected and feared. He holds an important position in the tribe and is showered with gifts to keep the natives in his good graces.

Divination

is the art of foretelling the future by the study of omens. From Biblical times down through the ancient Greeks and Romans, the people believed in sacrifices to appease the gods and to bring them good fortune. One popular part of Divination was the examining of the entrails of the sacrificed animal to determine the future. The diviner who performed this examination, most often of the heart and liver of the slaughtered animal, was called a haruspex. Other diviners made the people believe that the cries of birds and animals at certain hours of the day and in certain seasons were omens of good or evil about to befall them. These were called augurs. With the astrologers, you are familiar. They foretold events by the stars.

Among Ancient Romans

In ancient Rome divination was given a high place even in public affairs. Every public act was done under magical guidance. Cicero, the great statesman himself, was an augur. He observed the flight of the birds and their cries and based decisions on public policy on the omens which it was believed these things signified.

Roman divination was really a religious system of consulting the gods. It was believed that the gods sent particular omens to guide the people. Jupiter, the father of the heavens, was seen in thunder and lightning. These signs of the elements had tremendous importance when observed by the diviner in a certain section of the sky. The eagle was Jove's messenger and gave high hope of victory, while the owl was the most unlucky bird when it cried dismally. Sacred chickens gave omens according to whether or not they were eager to feed and dropped crumbs on the ground. The good or bad signs from other birds depended on whether they were on the right or left of the augur.

So important a part did Divination play in Roman public affairs that foreign soothsayers thronged to Rome to practice their art among the rich Romans.

So you see Magic was then a profitable business, as it is today.

Both Necromancy and Divination form the background of modern day Superstitions. In the next lesson I will take up the development of Superstitions from their Magical origins.

* * * * *

I am sure that you are convinced by now that this course is scientific. You must realize that you are learning things about magic that you can get nowhere else - things that the average magician does not give a thought to, yet things which are vital to Magic. You must know by now that you will be a different kind of Magician -- a Scientific Magician.

Today we will continue with the Psychology of Magic. This time I will discuss the Credulity of People.

PEOPLE WILLING TO BELIEVE

In line with the Power of Suggestion, discussed in Lesson 2, is the Credulity of People, their Willingness to Believe.

Always remember that the first impulse of people is to believe. Doubting is secondary.

To make it clear to you, I will give you this example. When you read something in the newspaper not honorable about a man whom you thought highly of, for instance, your first impulse is to believe it. You probably say, "Who would have thought that Mr..... would be involved in anything of such a nature?" Then after this belief may come a reaction and the thought that perhaps you should not believe the newspaper. You have, no doubt, experienced in other ways this tendency to believe what you are told. We all know the malicious stories of the old-maid scandalmonger. Her stories are so harmful because of this willingness of people to believe what they are told. Her vicious tales sometimes sound so true that some people don't even get the reaction of doubt.

So it is in Magic. People want to believe that you make that coin disappear, that you vanish the burning cigarette. When you tell them that they have the coin under the handkerchief in Lesson 1, far be it from them to doubt you.

In Magic there is almost no tendency to the reaction of doubt.

So remember, you are betting on the safe side when you play your stakes on this impulse of people to believe.

Seeing, Hearing, Feeling with the Imagination

We can carry this further. People believe not only what you tell them or what they actually see or hear or feel, but

they believe what they imagine they see or hear or feel. Imagination plays as tremendous a part in forming ideas as the senses do.

A common example of seeing with the imagination is one that we have all, no doubt, experienced. I refer to meeting a man on the street and saying "How do you do" to him, thinking he was Mr. James. There was a similarity of features between this man and Mr. James and your imagination formed the idea that he was Mr. James. It proved not to be Mr. James at all, and if you had looked at this man with your eyes, you would have seen that he was not Mr. James. You saw him, however, not with your eyes but with your imagination.

Now this is how seeing with the imagination applies to Magic. In the Mystery of the Burning Cigarette you suggest to your audience that your hand is empty by showing it to them with the thumb tip pointed toward them. They believe that your hand is empty and consequently do not look for anything on your hand. They imagine they see nothing on it.

This applies also to the senses of hearing and feeling. In the Dissolving Coin trick, you suggest to them that the coin is under the handkerchief, and when the spectator takes the disk under the handkerchief in his hand, he imagines he feels the coin. Also you have suggested to him that he is dropping the coin and consequently he imagines he hears the clinking of the coin when he drops the disk. As a matter of fact, if he really felt with his hands and not his imagination, he would feel the disk because it does feel different from a half dollar. And if he were hearing with his ears and not his imagination, he would hear the disk because its sound is different from that of a half dollar.

You are safe, however, in counting on the willingness of your audience to believe what you tell them and on their using their imaginations instead of their senses of seeing, hearing, and feeling while you are performing. This has been true since time immemorial and holds true today. It is an infallible part of the working of the Psychology of Magic.

Magic is so bound up with this science that almost its whole basis is Psychology. Psychologists the world over are intensely interested in Magic for that reason. Magic gives them an insight into the working of people's minds such as they could get from no other profession. I give you this Psychology of Magic so that you may understand how closely Magic is interrelated with psychology. Its relation with other sciences I shall discuss with you later.

* * * * *

Principle:

Art of Misdirection

Directing the eyes of your audience is another great power you have and the principle of the Art of Misdirection plays a tremendous part in Magic.

(3-4)

The audience follows your eyes. You have a palmed coin in your left hand, for example. You hold it in a natural position and look at your audience and use your right hand while giving them the patter. Your audience will follow your eyes to your right hand and will not even glance at your left hand, which has the coin. That is why I told you in Lesson 1 not to watch your hands. Even a hasty glance will lead someone in the audience to follow your glance and suspect that you have something concealed.

You may try this little experiment to prove to yourself that people follow your eyes. Pretend you are throwing a coin up into the air and look up to an imaginary point that the coin reached – but really retain the coin in your hand. The eyes of the spectators will look upward just as you did. You can do this many times and each time the audience will look upward.

Almost every trick has some element of Misdirection in it. So remember, in performing your trick – NEVER LOOK AT THE OPPOSITE END OF YOUR EFFECT. By the opposite end, I mean the thing you are really doing -- that is, looking at your hand which is holding the coin, rather than looking upward for the effect. If you look at your hand, the audience will look at your hand—that is the opposite end. If you look upward, the audience will look upward -- that is the effect.

That is the basis of Misdirection. Whatever you direct their attention to, the audience will look at. In the Dissolving Coin trick you use the Art of Misdirection when you direct the attention of the audience to the dropping of coin (?) in glass. Every person in that audience is watching to see what will happen when handkerchief is lifted and you must look in that direction also. Meanwhile, you can put your left hand in your pocket to dispose of the coin without being detected.

One thing you must keep in mind is that it is a psychological fact that a person does not hold his attention on any one thing for more than a few seconds. Your job is to keep renewing his attention by the things you say or by varying the thing this person is to attend to -- until you get your work out of the way.

You must work fast so that you don't bore the spectator and find him watching you instead of the thing he should be watching. You must remember that his attention wanders and you must be quick so that you are through with your "opposite end" before his attention comes back to you.

To get the Art of Misdirection clearly into your mind, I want you to practice this little move:

Stand before your mirror and watch yourself.

Take a coin in your left hand. You are going to get the effect of passing it to your right hand. For a few times really pass the coin from your left to your right hand. This

is to give you Naturalness in faking the pass and also to give you an opportunity to observe how your eyes go from your left to your right hand.

After you have done this a few times, go through the same moves but retain the coin by finger palming it in your left hand. Close your right hand as if you had the coin. Your eyes must follow the pretended passing of the coin just as they did when you actually passed it. Your audience will follow your eyes to your right hand and will not even notice your left hand.

It is unbelievable until you try it yourself how easily large objects – even a rabbit – can be moved about almost under the very noses of the audience without their seeing or suspecting anything if you know the Art of Misdirection.

Nearly the whole art of Sleight of Hand depends on this Art of Misdirection. Your seemingly miraculous effects depend on speed and cleverness in directing the attention of the audience away from the opposite end of the effect -- away from what you are really doing. You will find this intensely interesting when we begin to study Sleight of Hand.

* * * * *

In training you to be a Magician, I am training you to be so well equipped with the principles of Magic and effects that you can vary your tricks to fit any occasion and to be ready to meet any emergencies when you are performing.

I give you variations of tricks based on the same principle. Sometimes it may be necessary to repeat a trick within a short period of time and some of the old audience may be in the new one. You can throw these spectators off the track by presenting the trick by a different method of working. You can add some little twist to the trick, and even those who see it for the second time will not discover how you do the trick. There are "close investigators" in some audiences. You will have no difficulty in mystifying them if you vary your effects, even just a trifle. I give you also similar effects based on different principles.

A magician often fools another magician with just this style of working. He will introduce a new twist of some kind or a new method of working and he has his fellow magician puzzled.

In this lesson I teach you String and Ring Tricks—two methods of taking rings off a string that is held at both ends, and a method of removing a ring made by tying a knot in the string itself.

You can always carry with you the apparatus for these tricks so that you are always prepared to do them. They are impromptu effects that go over big anywhere. Try them in the office of a business friend or at some friendly gathering.

METAL RING ON A STRING

EFFECT:

A metal ring about an inch in diameter is given to a spectator to examine carefully, also the same is done with a piece of string about two and a half feet long. The spectator is asked to thread the ring on the string and to hold both ends of the string securely. Performer then covers the ring on the string with a handkerchief, and in a few seconds takes handkerchief away and shows that he has removed the solid ring from the string while the spectator was holding the ends tightly.

PARAPHERNALIA:

We have given you FREE the paraphernalia for performing this trick:

1--Two metal rings, nickeled, about an inch in diameter.

The other articles you will need are:

a--A piece of string or soft cord about two and a half feet long.

b--A pocket handkerchief.

SECRET AND PATTERN:

To prepare: Place one ring with handkerchief in the right trousers pocket or coat pocket. In another pocket place the other ring and the piece of string.

Take from your pocket the ring and string (or you may borrow a piece of string).

"I am going to show you an odd experiment with a small metal ring and a piece of string. But before doing so I want someone to examine this ring very carefully to see that it is solid."

Give Ring to Spectator.

"If it were not, I certainly would not ask such an analytical person to examine it. Also look this piece of string over closely."

Give Spectator the String.

"You are quite certain, are you, that there is no hole in the ring?"

Run Finger Through the Ring Itself.

"It wouldn't be a ring without a hole, would it? Now, if you will just thread the ring on the string please!"

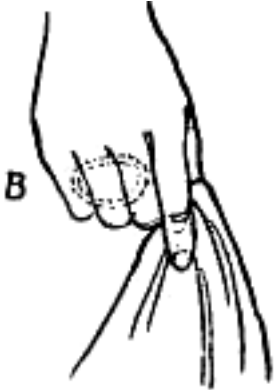
"Please hold both ends of the string securely and remember don't let them go!"



Give both ends of the string to spectator. The ring hangs on the string between his hands.

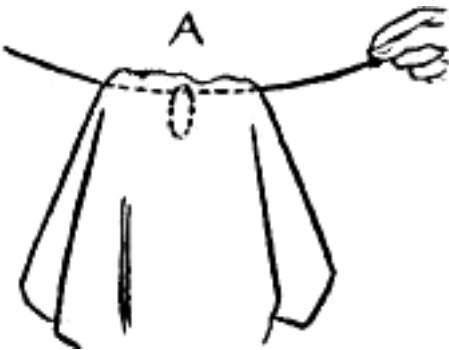
"There swings the ring on the string gaily between you."

While saying the above, reach into pocket with your right hand. Finger palm the ring in your pocket the way you finger palmed the glass disk in Lesson 1.



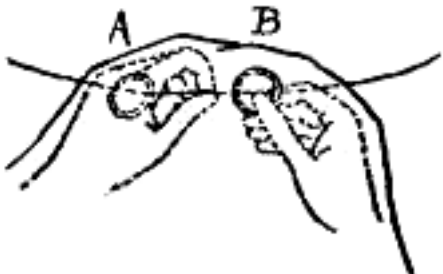
Take handkerchief from your pocket at the same time. To the audience it looks as though you had just reached into your pocket after handkerchief. They do not know that you have an extra ring and that you are concealing it in your right hand. In the illustrations I have marked the concealed ring "B" and the ring which the audience sees is marked "A". Notice however that as the trick progresses, these rings change places. That is, ring "A" becomes the concealed ring and ring "B" is seen by the audience.

"Have you ever heard of 'Trans-figure-ma-gumption'? I don't suppose you ever have. It is a process of materialization and dematerialization of solid objects under an invisible coat. This handkerchief can be the invisible coat."



Cover ring on string with handkerchief.

"Of course, the handkerchief isn't invisible, but it does make anything under it invisible, doesn't it?"



With both hands, reach under the handkerchief. The left hand covers the ring on the string (A) and pulls it away from center toward left side. The ring in right hand (B) is placed against string in its place. Turn to spectator holding string.

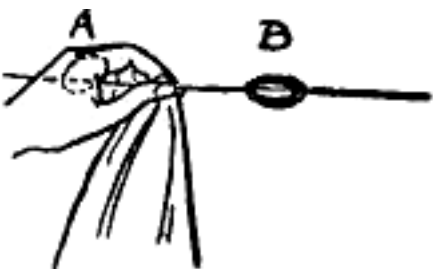
"Let me have a little slack in the string please. That's fine."



Now you place ring (B) on the string. How to do this is illustrated at left. Put ring between thumb and first finger of left hand. With right hand, bring string through ring and over the top edge. When string is drawn taut, this loop arrangement holds ring in place.

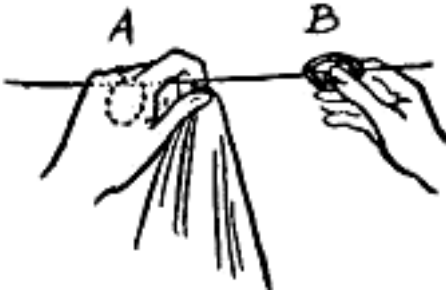


With left hand covering ring (A), hold string about four inches from ring (B) and pull string taut.



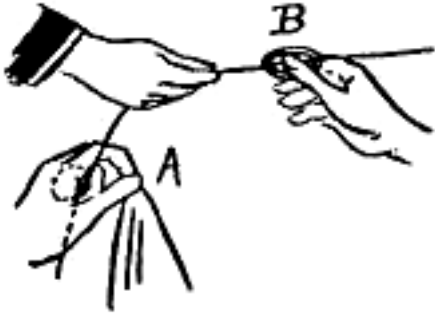
Remove handkerchief with right hand and put it between index finger and thumb of left hand. Other fingers are closed around string in order to conceal ring (A).

"I thought at first that I would show you the principle of transfigure-ma-gumption under cover of the handkerchief, but upon second thought, I believe you may understand it better if you see what has happened. The principle being, of course, that the more you see the less you know."

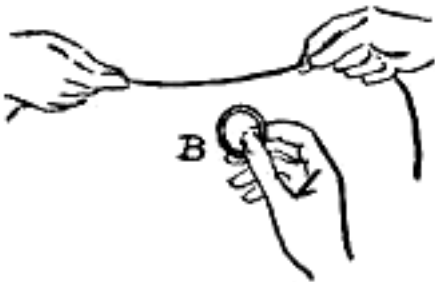


Hold ring (B) with thumb and first finger of right hand so as to prevent its slipping from string. Then to the spectator who is holding both ends of the string, you say:

"Now, sir, if you will please reach down and take hold of the little loop you will find that the ring will come right off. I will hold this end of the string for you."



As spectator lets go of left end of string and reaches down to remove ring "B," you slide your left hand with ring "A" concealed in it, to left end of string.



When he removes ring from string you put handkerchief and ring into left-hand pocket.

Hold ring up for all to see

"You can examine it again, sir."

Give ring to spectator.

"And if you will look at the string closely, you will find it hasn't been hurt in the very least. That's the beauty of transfigure-ma-gumption, it is painless."

You will find this trick to be very much easier to do when you have one spectator hold both ends of the string. You are advised not to try having one spectator hold one end and another spectator hold the other end of the string, until you have become quite proficient.

THE PATRIOTIC RINGS AND STRING

EFFECT:

Three paper rings—red, white, and blue, respectively—are examined, also a piece of string or soft cord about two and a half feet long. The rings are strung on the string, one end of string being given to some member of the audience to hold and the opposite end to another. Performer covers rings with a handkerchief, hiding them from view, and requests that someone select one of the colors of the rings. Someone, for example says, "red". Placing his hands under the handkerchief, performer removes the red ring and brings it out without tearing it. He shows that the blue and white rings remain on the string. Any color which is selected may be removed in the same way.

PARAPHERNALIA:

I sent you FREE a number of these colored paper rings. For this trick you need:

Two Red Rings.

Two White Rings.

Two Blue Rings.

Other articles you need are:

a--A piece of string or soft cord about two and a half feet long.

b--A handkerchief.

SECRET AND PATTERN:

To prepare: Have one each of red, white, and blue rings in right trousers pocket. The rings should be arranged in order. Have handkerchief in same pocket.

Place other three rings in your vest pocket. Have string with you or borrow it.

Take three rings from vest pocket. Show rings and string to audience.

"For this experiment I would like two gentlemen to help me."

Have two men come forward. One should be placed a little in front of you and to your left and the other one in a similar position to your right.

"I have three patriotic rings--red, white, and blue."

Show each ring separately. Turn to gentleman on left.

"Will you be so kind as to give them a careful looking over?"

Turn to gentleman on right.

"And will you please examine this piece of cord."

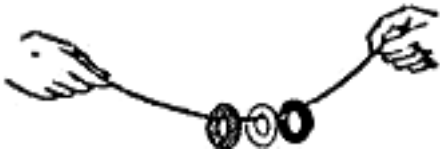
After cord has been examined--

"Now, if you will just hold one end of the string and give me the other, I will have this gentleman (at left) string the three rings on the cord. Thank you, that's fine. Now just hold the end of the string."

To Audience--

"What have we? Three rings which the gentleman has examined--red, white, and blue--on a cord and a gentleman"

holding each end of it. Be careful, sirs, and do not let go of the string at any time while the trick is in progress. Do you know, this trick reminds me of the Chinese—the rings look so much like washers."



While saying this to audience, separate the three rings so that they are about an inch and a half from each other. Then reach into right trousers pocket and finger palm the three rings. Be sure you know the order in which they lie in your hand. At same time, bring handkerchief out of pocket. As in the effect before, the audience thinks you have merely reached into pocket for the handkerchief and they are not aware of the fact that you have three extra rings in your right hand.

"For a moment I will just cover the three rings with this handkerchief."

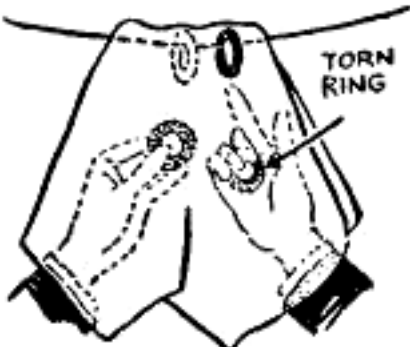


Cover rings with handkerchief, allowing right hand to rest partially under it. Hand still holds handkerchief so that palmed rings are screened by it.

"These rings are very sensitive and are very much subject to anyone's call. I have known them to run away when spoken to loudly. Will anyone call out the color of one of the rings—red, white, or blue? Take your own free choice. Red? Then red it shall be."



With both hands under handkerchief, reach up to red ring on string. TEAR it as quietly as possible and remove it from string with left hand.



Now take red ring from right hand into left and put torn ring in right hand. The red ring should be the top one in the right hand when you palm the three rings.

You now have two good rings (white and blue) and the torn red one in the right hand. You have the whole red ring in the left.

Bring left hand from under cover, holding up the red ring. At the same time, pull away the handkerchief with the right hand in which you have the three rings finger palmed.



"There, didn't I tell you that any ring was apt to run away when loudly spoken to. I did manage to catch the red ring, however, and here it is. The white and blue rings still remain on the cord."

As you say this, put handkerchief into pocket and leave rings with handkerchief.

Turn to gentleman on left. Show him red ring.

"You will observe, sir, that the ring has not been damaged at all--just a wee bit scared. And now, let me ask of you--"

Take string with white and blue rings on from gentlemen and hold in your right and left hands, rings hanging between them.

"Please don't tell anyone how the red ring escaped from the string without being injured."

If anyone had called for the white or blue ring, the method of working would have been the same except that you would have torn off the white or blue ring instead of the red one and would have transferred from the right to the left hand the ring of corresponding color.

Compare closely the method of working the first effect with the metal ring and the second effect with the paper rings to impress upon your mind the difference in working.

THE VANISHING RING OR STRING

This is a good effect with which to follow either of the above tricks. You use only the string.

EFFECT:

Performer ties a single knot in the center of the piece of string, single knot forming a ring. He ties the two ends of the string together four or five times so as to make a rather long knot. Then he tells someone to try to take the ring off the string without untying the ends. After the spectator has failed, magician takes string in hands and asks spectator to take out his own handkerchief and cover performer's hands.

In a moment performer withdraws his hands and shows that ring has vanished from string.

PARAPHERNALIA:

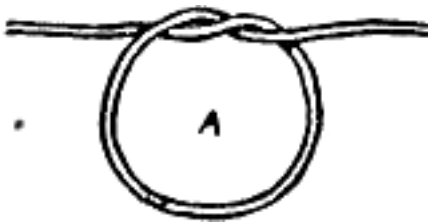
a--A piece of string--the one you used for either of the other effects in this lesson.

b--A borrowed handkerchief.

SECRET AND PATTERN:

Have string in your hand.

"You saw the ease with which a solid ring escaped from a piece of cord. Now let me show you a similar effect. First, I will make a ring by tying one in the string itself."



Take string and make a single knot to represent ring.

"Now instead of having two gentlemen hold the ends of the string, I will, for convenience sake, just tie them together in this manner."



Tie ends of string together, making five or six knots.

"It would take Houdini himself to escape that tie. Now will someone just try to take the ring off the string without untying the string?"

Give string to spectator, and after he fails to take ring out of string, take string back from him.

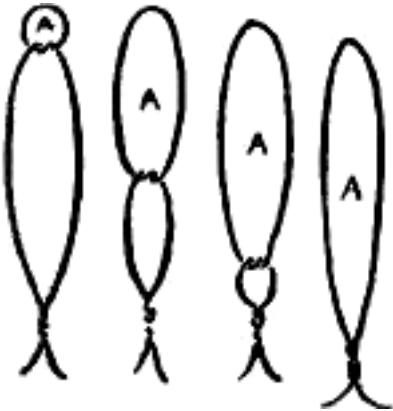
"Just as I said, it would take Houdini himself to get away from those ties. Will you, sir, kindly let me have your handkerchief? Throw it over the string and my hands so that they are both covered. Hold it there just a moment."



Spectator should be at side of you so that he does not screen you or the handkerchief from the audience.



As soon as your hands are covered, simply slip fingers into small ring; enlarge it and keep on enlarging it until the knot disappears into the other knots.



All you have really done in disappearing the ring is to tie another knot from the end opposite to the other knots in the string.



SIMPLE! Of course, that is the beauty of it. Ring has disappeared. Bring string out from under handkerchief and show to spectator and audience. Hold string by one end so that audience may have no doubt that ring has gone.

"There, you see the ring has disappeared. A strange thing this magic business."

LESSON 4

Your next lesson includes three effective paper tearing tricks:

1--A piece of colored tissue paper is torn into a number of pieces and then rolled into a small ball. The paper never leaves the sight of the audience, yet when magician blows upon it, the ball is unrolled and the tissue is found to be restored.

2--Magician tears same paper into number of pieces again and puts them into glass half filled with water. He removes wet pieces and squeezes water out of them. Then he fans them and they turn into dry confetti, which falls from his hand.

3--Magician tears paper napkin into small pieces and rolls them up into ball. He opens the ball and napkin is restored. He then offers to show how it is done and repeats the experiment. The mystery when he finishes, however, is as great as ever.

A handwritten signature in cursive script that reads "Harlan Tarbell". The signature is written in black ink on a white background. The letters are fluid and connected, with a prominent flourish at the end of the word "Tarbell".

TARBELL SYSTEM, INCORPORATED, Chicago.

(3-14)

DEVELOPMENT OF SUPERSTITIONS

In this History of Magic I aim to give you an insight into the development of magic from the earliest times down through centuries to the present. No one has ever adequately covered this tremendous subject. It would take many volumes to write a complete history of magic. And yet I want to give you a fairly complete picture of the progress of magic down the ages.

It is a huge task to put together the knowledge the world has on magic. We have some information on magic in ancient times and some information on magic during the middle ages; but these records are scattered and incomplete, and were they all to be assembled they would fill ponderous volumes. What history has been recorded I have collected and I am giving to you the high spots in a concise form. I am tracing for you the various phases of magic to give you the background and importance of magic so that you may the better understand modern-day scientific magic.

Today I take up the subject of superstitions. I know you will be very much interested in this subject because it is one which we are all familiar with in every-day life. You know many people who still believe in these old superstitions -- and perhaps you, like so many others of us poor mortals, are just a little superstitious too.

Our modern day superstitions, of course, had their origin in ancient magic. From the beginning of things almost, down -- down the long dim avenues of time have come these magical beliefs, closely intertwined with religion, with medicine, with social life.

Divination Foundation for Superstitions

The Art of Divination furnishes almost the complete background for the superstitions people believe in today. With primitive people these magical beliefs of divination are, of course, the very foundation of their lives. I told you in a previous lesson of the belief of some barbaric tribes in charms and incantations -- and the belief of even civilized peoples like the Romans in augury and other forms of divination.

Magic in Savage Lands -- Superstitions in Civilized

Strangely enough, these same beliefs are found today among savage tribes still as magical beliefs, and among civilized peoples as superstitions.

Shooting stars and comets are to the natives of barbaric tribes omens of disaster -- and to the superstitious of our country, they signify death. The hawk's cry in the night portends the death of a child in far-away Australia; and the barking of a dog at night in front of a home to some of our people indicates death in that home.

Incantations – Modern Curse

Incantations to bring about certain acts are common among primitive peoples. Repeated utterance of a blessing or a curse was believed to bring about the desired good fortune for the person blessed or disaster to the accursed one. The modern curse is an outgrowth of this, and while it is no longer regarded as a means of vengeance and is really only an expression of anger, back of it still lies some of the element of the incantation from which the curse originated.

Charms – Mainstay of Sorcery

Charms, you know, are one of the mainstays of sorcery. There are two kinds of charms – one, amulets and talismans, which are gems or stones or other objects which are said to guard from harm the person who carries them about with him; the other, casts spells by pronouncing certain words with the use of some object.

Barbaric tribes still retain these beliefs in charms. There are sacred gems and stones which, according to these people, can bring sight to blind eyes, can give strength to the weak. When the sorcerer chants certain words with the aid of a stone or other object, he can overcome the influence of the "evil eye" and can make the sick well.

Charms Among Moderns

Today we find these same beliefs, though somewhat modified, among people of our own country. The superstition that the opal is an unlucky gem and that pearls signify tears is nothing but an outgrowth of the ancient belief in magic gems. You have known men to carry about with them charms of some kind – a coin that was found, a bit of quartz or flint, a rabbit's foot. These men may not really believe or may not admit that they believe in the working of these charms – nevertheless, they carry them to be "on the safe side." They want to be sure, in case there is something to these charms, that they won't be "caught unaware" if there is any evil floating around their vicinity, or that they won't be unprepared to attract good fortune. So firmly have these beliefs been imbedded in our minds that, even against our better judgment, we still halfway believe them.

The old magical belief that a loadstone or magnet, because it draws steel, will also draw out pain still exists. Many a peasant in Europe carries a magnet in his trousers' pocket to ease the pain of his rheumatism. And even more enlightened people will wear, with as great confidence in its effectiveness against rheumatism, a "galvanic belt," though any electrician will tell them that it has not the power to hurt or cure a fly.

Spells to Overcome Evil Influences

Spells cast over anyone work miraculous effects, according to the beliefs of the natives of uncivilized

regions. The same spells that were cast over men thousands of years ago, no doubt, are still being exercised today. The use of sticks or strings or stones and the muttered chanting of the sorcerer to overcome evil influences has been passed on from generation to generation to the present.

I remember witnessing the casting of a spell about fifteen years ago. The child of a family I knew was ill and was believed by her mother to have come under the "evil eye." The child's grandmother took a number of broom straws, crossed them in her hands in a certain way, and pronounced some words. It was believed that this made the child well. Another time this same child became ill again and it was believed that the child had been frightened by something and that caused the illness. The grandmother, this time, melted a small quantity of lead in a pan and poured it into cold water. The lead solidified into a shape that resembled a dog and the conclusion was drawn that the child had been frightened by a dog. The grandmother, of course, was not regarded as having supernatural powers, but was believed by the superstitious neighbors to "know how" to cast the spells.

Some Common Superstitions

The derivation of many of our present-day superstitions has been lost. One generation learned them from another, and so they have been passed down through the centuries. It is small wonder that some of them have changed somewhat from their original forms and the explanation for many has been completely lost. The superstitions still live in spite of the fact that their association with the things they are believed to influence is very vague.

Take spilling salt, for example. This is a sign of a quarrel when it is done at the table. The connection of salt with a quarrel has been lost, but the superstition still lives; and you have, no doubt, seen many people throw salt over their left shoulders to break the evil influence of spilling salt.

The origin of the misfortune connected with the number 13 and its heightened ill effects when it is Friday the 13th is no longer known to us, yet this superstition holds the belief of many people.

Why the horseshoe is a charm which brings good luck is unknown. The use of the horseshoe as a charm is evidently of more recent beginning than some of the other superstitions as, of course, horses were not shod in primitive times.

There are many, many other beliefs which I could discuss with you, but space will not permit and I must wait until the next lesson to continue with my absorbing work of delving into the dark recesses of magic's past.

REVIEW OF PRINCIPLES

Lessons 1, 2, 3

The History of Magic, I know, must have been very interesting to you. It gives you a bird's-eye view of the development of Magic from ancient to modern times, it gives you an understanding of the two branches of Magic – Sleight of Hand and Necromancy and Divination.

Now read over again my section on Magic as a Science in Lesson 1. You can't read this too many times. I want you to get the spirit of it and the big idea back of it into your mind so well that it becomes a part of you.

I hope you are maintaining the Professional Attitude in your studying. Don't ever let down on your studies and be satisfied with amateur ability, but keep your determination that you will gain professional skill.

Remember to concentrate on every detail, for as I told you, the simplest details are often the most important.

You must by this time have the ability to hold your hands in a natural position. Don't let it go at that. Keep this constantly in mind and watch for any awkwardness.

To summarize the three lessons, I will list for you the fundamental things, which we studied, upon which the whole Art of Magic and every trick depend. Review my discussion of these principles. Do not be satisfied with any less than a complete understanding of them for they are vital. Then go through the tricks of the three lessons again with the following in mind:

- 1 - Naturalness of Hands
- 2 - Angle of Visibility
- 3 - Good Presentation of Patter
- 4 - Power of Suggestion
- 5 - Credulity of People
- 6 - Art of Misdirection
- 7 - Finger Palming
- 8 - Thumb Tip Manipulation

Now just think of these eight important elements in the presentation of your tricks. The ordinary magician does not give some of these things a thought. He probably uses them unconsciously, but not with the understanding which comes from conscious knowledge of the scientific aspect of magic. He would not know what you were talking about if you asked him what part the Power of Suggestion plays in magic. Therein lies the difference between the ordinary magician and the kind of magician you will be when you have completed this course. Therein lies the difference between the ordinary magician and you as the scientific magician you will become because you are studying this magic course, which has been written from the scientific standpoint.

LESSON 4

This week we take up another branch of conjuring in which you work with TORN AND RESTORED PAPER effects. It enables you apparently to destroy a piece of paper and then to restore it to its original condition.

Practice every move carefully before the mirror and do not try to perform the tricks until you have mastered them.

These are beautiful effects and will help make a reputation for you. They are excellent for performance at a club or on the stage.

* * * * *

CHINESE PAPER MYSTERY

Many years ago a famous Chinese magician, Ching Ling Foo, came to this country. His oriental mysteries were so cleverly performed that even magicians were baffled at the methods he used to obtain his effects. Prominent on his program was an effect in which he showed a piece of tissue paper, tore it up, and restored it again. When I was a boy, I heard of the wonderful mysteries of this clever mystifier and was particularly impressed with the torn and restored paper effect. I set about to find a method by which the effect could be duplicated. The result was the one I am giving you first in this lesson.

This effect has puzzled many, many audiences, and with it I have fooled many magicians too. I have since learned that what was an original method to me was very similar to that used by Ching Ling Foo.

EFFECT:

A sheet of colored tissue paper, about 3 1/2 inches by 15 inches, is shown on both sides. Performer rolls sleeves to elbows and shows hands empty. The paper is now torn into a number of pieces, which in turn are rolled into a ball. Attention is called to the fact THAT THE BALL OF PAPER NEVER LEAVES THE SIGHT OF THE AUDIENCE. The performer opens the ball of paper, however, and it is found to be fully restored. It is again shown on both sides and hands are shown empty, fingers wide apart.

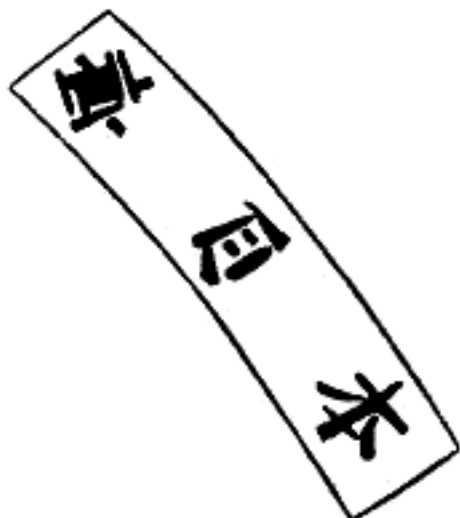
PARAPHERNALIA:

Two pieces of heavy dark-colored tissue paper, about 3 1/2 inches by 15 inches in size. Pieces of paper must be exactly the same size.

The more nearly opaque the paper is, the better. A purple or dark green paper is safest. A few years ago good tissue paper was easy to get, but since the war, the quality has been poor. For this reason the effect has had to be modified sometimes by painting Chinese figures on the tissue to be used. Experimenting will soon tell you whether it is necessary to daub figures on the tissue or not.

CAUTION:

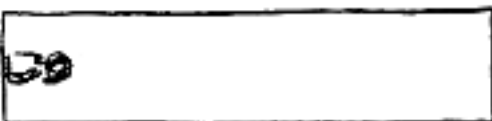
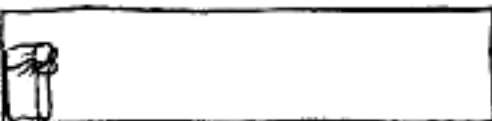
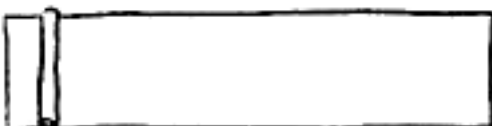
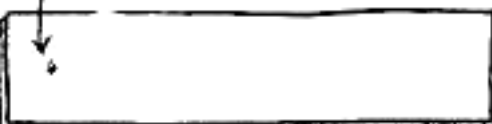
In trying a tissue that is new to you, examine it carefully when you have ball in place (as explained later). Can you see ball from other side because of transparency of paper? Does it give a black shadow effect? If it is noticeable at all, you will have to remedy it by painting Chinese figures on paper (as in illustration).



Use three Chinese characters or letters as shown, one coming in front of place where ball will be. If black paint or water color is used, you will find that the design will readily shield a ball behind it. The designs, of course, are painted on the opposite side of the paper from where the ball is. The two papers must be painted alike so that the first piece will look like the second. The audience thinks you use only ONE piece of paper.

BEWARE OF ANY LIGHT BEHIND YOU. LIGHT MUST STRIKE FRONT OF PAPER. If you cannot avoid rear lighting, then be sure your Chinese figures are big and heavy enough to conceal ball when light comes through paper.

DROP OF GLUE BETWEEN PAPERS TO HOLD THEM TOGETHER



SECRET AND PATTEN:

To prepare: Lay one strip of paper on a table. About 1 3-8 inches from the left end, place a drop of glue. Place the other strip on top of the first and press paper at glue area so that the two strips will stick together. Let glue dry.

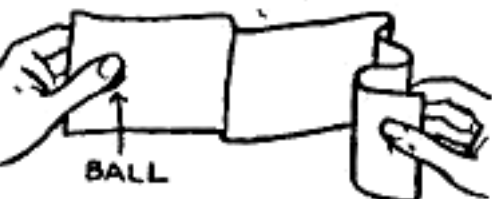
Starting at the right end, fold top strip in one-inch folds up to glue. Double the fold. Fold over top, then bottom to center, then left end of strip to form a tight ball. It must be folded tight so that the ball will not undo itself.

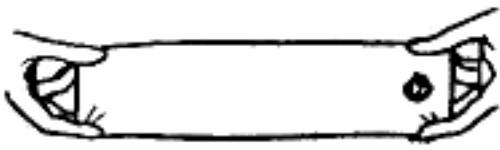
The result is a strip of paper with a ball of paper glued onto it. Fold up strip and place in your pocket. You are ready to begin effect.

"Some time ago a great Chinese magician came to this country -- Ching Ling Foo. He was a master mystifier. Even magicians were baffled by his cleverness. I shall never forget the first time I saw him back in the year 1849 (or you can give any other year before you were born). I remember how after he rolled up his sleeves (roll sleeves up), he reached into his pocket and took out a piece of tissue paper about this size (reach into pocket and take out prepared tissue), which he would unfold."

Unfold tissue so that ball comes to rear and is concealed from the audience. At no time should audience get a glance at ball.

Hold paper so that audience can get a good view of hands and see most of the unprepared side of paper.





They can see all of paper if you shift your fingers slightly.

(4-6)

"He said this was Chinese paper, and so that you might see the point, he had a Chinese character placed on each corner. (Call attention to the corners). Then he would say, 'You see my right hand'."



Hold paper with left hand and show right hand slowly and carefully, fingers wide apart.

"And you see my left hand..."



Transfer paper to right hand and show left hand, fingers wide apart.

"And the paper -- peculiar paper, because it has a side on this side and a side on the other side."

Hold paper in left hand, thumb covering ball. In calling attention to side of paper which left fingers are on, give paper a quick downward stroke with tips of right fingers, front of hand towards audience.



Then turn paper over, thumb of left hand concealing ball. Again give quick stroke with back of right hand. This quick movement tends to overcome close scrutiny of upper part of paper where ball is concealed with left thumb. Turn paper back to original position, ball at rear. Hold paper up again by tips of fingers and thumbs of both hands so that audience can see insides of hands and almost all of paper. ALL OF THIS IS DONE TO CONVINCe AUDIENCE THE YOU USE ONLY ONE SHEET OF TISSUE PAPER AND THAT YOU HAVE NOTHING ELSE IN YOUR HANDS.

"Then he would tear the paper into a number of small pieces."



Hold paper with left hand and tear with right right hand, placing each piece as torn in front of the piece with ball on it.

After you have torn the paper to the end, tear through the pieces all together, taking care not to disturb paper within a half inch of ball. One tear with all the pieces is enough.





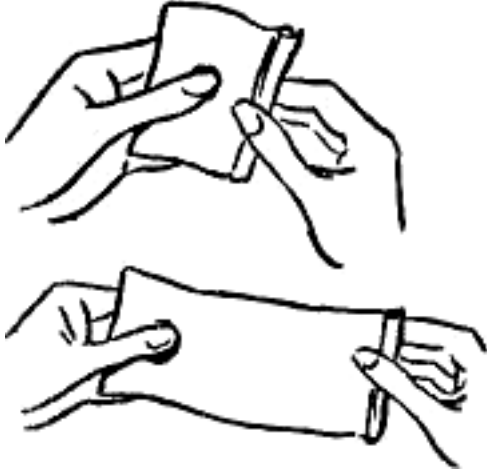
"Which he would roll into a small ball, his idea being that the smaller he rolled it, the littler it would become."

Push the paper forward and work into a ball. The piece on which ball is attached acts as a wrapper for the other pieces. You now hold two balls of paper, held together with the bit of glue.

(4-7)

To the audience it looks as if you hold ONLY ONE BALL. Balls should be held one in front of the other. Hold ball so that hands can be freely shown empty and ball ALWAYS IN FULL VIEW. Never wholly cover it.

"He also called particular attention to the fact that the ball of paper never leaves one's sight. You can see the paper at all times. Then came those mysterious words, 'Al - de - be - ron - ti - co - fos - fic - a - form - i - o - van - der - spink - en - toot - le - heimer - chee - lee - bal - e - wong - wa', and then he blew on the paper twice. (Blow twice on paper). That was enough to make it happen. He opened the ball and unrolled it."



During this talk. turn balls around in hand so that ball of torn pieces comes to rear. Open up the ball of whole paper. This will conceal the torn pieces. Holding paper securely with left hand, thumb over ball, unroll paper with right hand. You will have no trouble doing this if you will open ball so that it brings paper to position as shown in first illustration at left. Unroll until paper can be shown in its entirety. Then hold it with tips of fingers and thumbs at each end, so that hands are shown empty and paper can be seen.

"And the paper came out just as it was in the first place. Again he would say. 'My right hand - my left hand - and the paper - a side on this side and a side on the other side'."

In saying this, show paper and hands as you did at beginning of the trick - always careful to conceal ball with thumb of left hand. As a finish, roll up paper and place in pocket, or else hold in readiness for next effect.

"There is one regret, however, about this experiment - and that is, I have never been able to find out how he did it."

* * * * *

WINTERTIME IN CHINA

This may be performed as a continuation of the effect just described, or it may be worked as a separate effect.

EFFECT:

After performer has done the torn and restored paper experiment, he again tears the paper into a number of pieces and places same in an empty glass tumbler. From another tumbler or pitcher he pours enough water into the glass to cover the torn pieces of paper. When the paper is well saturated, he reaches into glass, takes out the paper, and squeezes it tightly in his right hand to allow much of the water to run out. Performer then reaches for a fan and fans the wet paper. The paper then suddenly becomes dry and flies from the fingers like falling snow flakes.

(4-8)

PARAPHERNALIA:

1--A strip of tissue about 3 1/2 inches by 15 inches -- this may be tissue left over from Chinese torn and restored paper effect.

2--Another duplicate strip which has been torn or cut into small confetti-like pieces.

3--A tissue paper envelope same color as strip. Size, 1 3/8 inches by 1 3/4 inches.

4--A small Japanese or Chinese fan.

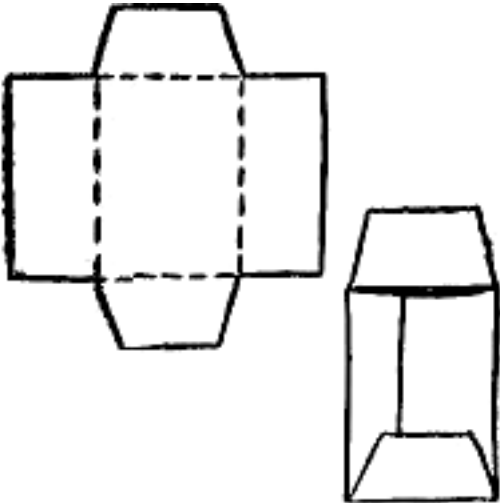
5--A hat.

6--Two glass tumblers. One empty, one three-quarters full of water.

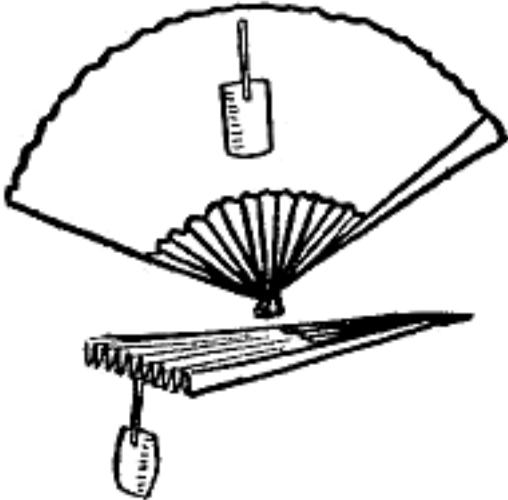
SECRET AND PATTERN:

To prepare: Make an envelope of tissue paper in this way: Cut a 3 1/4 inch square piece of tissue into a pattern like the illustration. Then fold over and paste to make envelope, bottom closed and top open.

Take a sheet of tissue paper 3 1/2 inches by 15 inches and tear or cut into small confetti-like pieces. Stuff these pieces into the little envelope and paste top flap down.



Open fan. On the back, paste the end of a small strip of tissue paper, about 2 1/2 inches long by 1/8 to 1/4 inch wide. On the other end of strip, paste the bag or envelope containing torn tissue.



Now lay the fan on a hat so that envelope hangs down into hat.

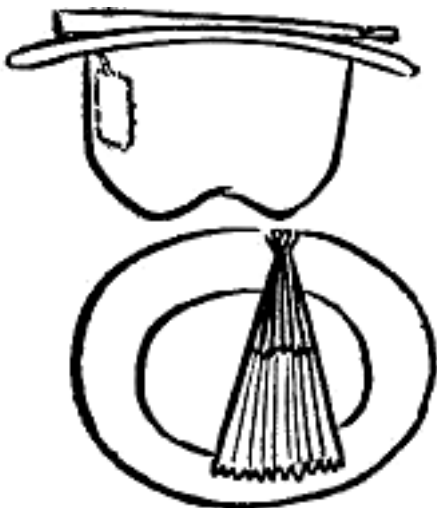
Leave fan slightly open so that it screens envelope from audience.

Of course, audience is not aware that such a prepared envelope exists.

Have hat with fan so arranged ready on a table at your left. Near it have two glasses -- one empty and one containing water. You are now ready.

Let us assume that you have just finished the torn and restored paper effect and have paper in your hand. You can begin something like this:

"Next I want to present a little play in one act, entitled 'Wintertime in China.' It is a very sad play and a tear drop may walk down your cheeks. It revolves around a little Chinese girl named Chee-Woo. Chee-Woo was very pretty. We will let this piece of paper represent Chee-Woo, all rigged out in her beautiful purple dress (providing you are using purple paper). Well. Chee-Woo fell in love,



but her father objected to her lover and the shock literally tore her to pieces."

Tear paper into a number of pieces, placing one piece in front of the other.

"So she left home and went out into the cruel cold world."

Put pieces of paper into the empty tumbler.

"And then it rained – oh, my, how it rained! Regular Chinese rain."



As you say this, hold glass with paper in it in your left hand, and with the right hand pick up the glass of water and pour water into other glass so that paper will be soaked.

"Which reminds me of a very subtle joke told about the Prince of Wales. You see, the Prince was standing on a corner talking to a friend. They were both standing under an umbrella. So the Prince says, 'It certainly is raining.' To which his friend replies, 'So's your old man'. It's quite subtle -- that job about the king reigning."

Now stir up paper in glass with first and second fingers of right hand.

"Anyway, Chee-Woo got very wet – in fact, she was sopping wet. And she said, 'I must get out of this dampness and find sunshine'."

Take wet pieces of paper out of glass and squeeze in right hand so water will run out. In the meantime, place glass of water on the table at left.

"She couldn't have been wetter if she had been swimming. 'But let me get into the sunshine,' said she."



Apparently place wet paper into left hand. THE AUDIENCE THINKS YOU PUT PAPER INTO YOUR LEFT HAND, but you don't. Let me show you how to do it as you will use the same or a similar "sleight" with other small objects later on.



After you have squeezed water from paper, it is natural for you to hold ball of paper between your thumb and fingers of right hand. Show ball. Now turn slightly to the left so that palm of left hand faces audience and back of right hand is to audience, ball concealed.



Apparently place ball in left hand, closing fingers slightly around the right hand.



Right hand now draws away, bringing ball with it, still held between thumb and fingers. Left hand closes quickly at same moment. The effect is that you have PLACED THE BALL OF PAPER IN YOUR LEFT HAND.



Try this before the mirror. Actually put ball into left hand at first, then try to get same effect but leave ball palmed in right hand.



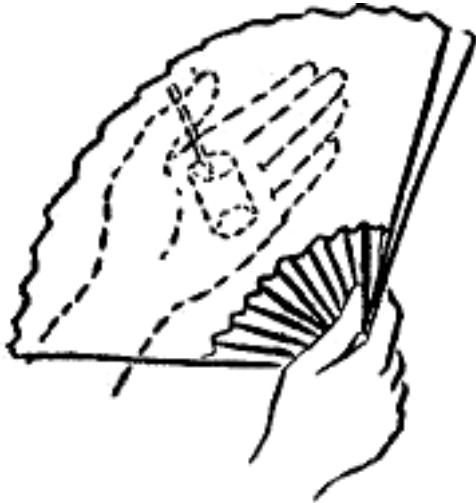
Reach for fan on hat with right hand, letting ball come a little beyond fan. Dip fingers slightly into hat and let ball drop into hat. Then pick up fan, allowing edge nearest to you, to come up first so that envelope attached to fan will pull up out of hat but will be hidden by fan.



As you pick up fan, spread it apart.

Hold fan in front of left hand. As soon as left hand is covered, open it and grasp envelope of torn pieces, tearing it from the strip. Then begin fanning.

"Then came the gentle winds. The winds of the four seasons came to soothe her."



As you fan, squeeze envelope, thus tearing it and releasing the pieces of paper so that they fall from hand like snow flakes. The fanning helps to spread them.

When the envelope is broken in hand in order to let the torn pieces out, it is naturally torn apart in the fingers in the process of moving fingers and thumb back and forth in scattering the paper flakes. The torn pieces of envelope fall with the flakes in small pieces.

"And swept her away to the heavens where she changed to snow - beautiful purple Chinese snow."



After all of the flakes have fallen and left hand is shown empty, say,

"And ever after – they have had winter in China."

The above effect may be done without patter, simply doing PANTOMIME. If doing pantomime, music helps put across the effect and you should use it when possible. Chinese or waltz music is most effective.

(4-11)



Instead of a hat on the table you may use a nice Chinese bowl of some sort; or if you have an assistant, he or she may hold your properties on a tray. This would permit you to dispense with using a table for the effect. If assistant is dressed in Chinese costume, so much the better.

* * * * *

JAPANESE TORN AND RESTORED NAPKINS

This is the usual method of doing the torn and restored paper napkin effect, and because of the finish in which the method is apparently exposed, this trick is very popular.

EFFECT:

A paper napkin is shown and torn into a number of strips. Magician rolls them into a ball, then opens ball and whole napkin is found to be restored. He then explains to the audience how it is done. He tells them that you use two napkins, one of which you palm in your left hand. You roll napkin into a ball and place in left palm. You take another napkin, tear it, roll it into a ball, and then exchange it for the ball in left palm. The ball when opened is, of course, the whole napkin. But what to do with the torn pieces now palmed in left hand? In case someone should see them, just unwrap them - and they are found to be a whole napkin as in the beginning. The audience is no wiser as to the "modus operandi" (method of working) than they were at first.

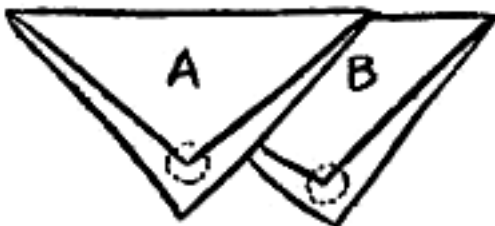
PARAPHERNALIA:

1--Four paper napkins, just ordinary thin paper napkins which are about 14 inches square.

2--A hat.

3--A pencil (full length).

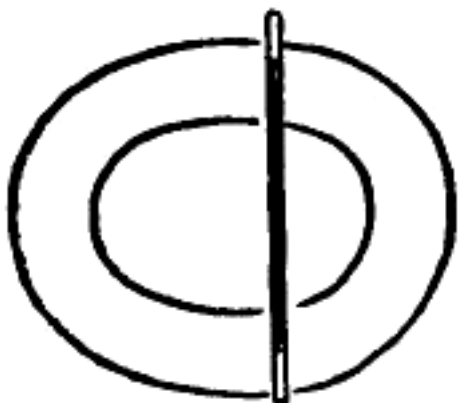
AUDIENCE HERE



SECRET AND PATTERN:

To prepare: Arrange two paper napkins on right side of table. Between corners of each napkin place a paper napkin rolled tightly into a ball, as shown in illustration. Note that napkins are folded over, concealing balls.

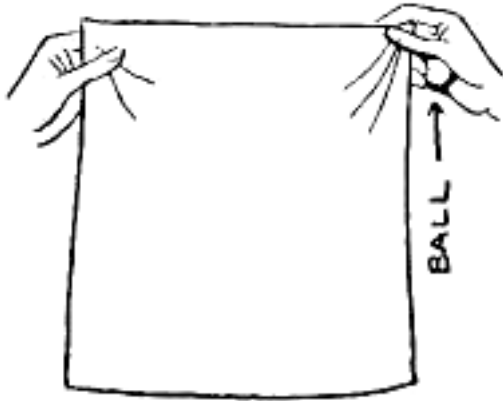
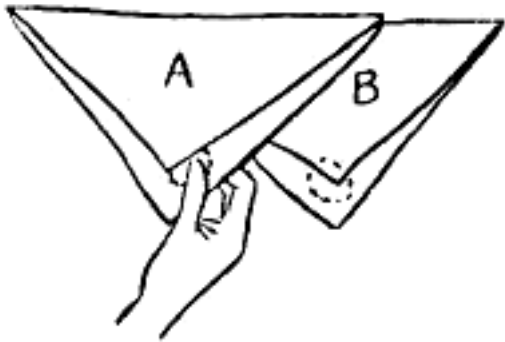
AUDIENCE HERE



At your left have another table or on the left side of same table, put a hat with brim up. Place your pencil over hat, end of pencil pointing toward audience.

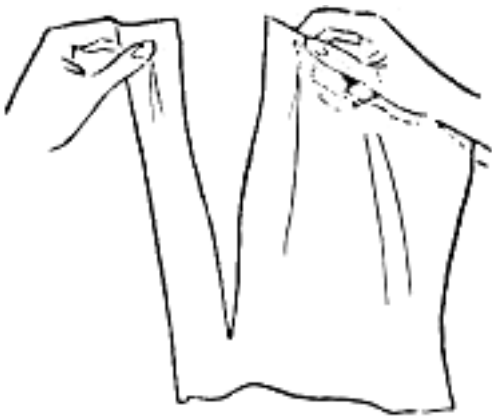
AUDIENCE HERE

Pick up napkin A with right hand, also picking up the concealed ball, which you finger palm in right hand with third and fourth fingers. The audience must never know that you have this concealed ball or that you use more than one napkin in doing the experiment.



Hold napkin with both hands and show it on both sides. The ball is meanwhile finger palmed in right hand.

"This is a Japanese experiment, an effect that has comb down from the Japanese conjurers of centuries ago. It is done with a square of Japanese paper or a napkin. An Englishman once said, 'It's a ripping good trick, Bah Jove' because I rip or tear the napkin into a number of strips or bits."

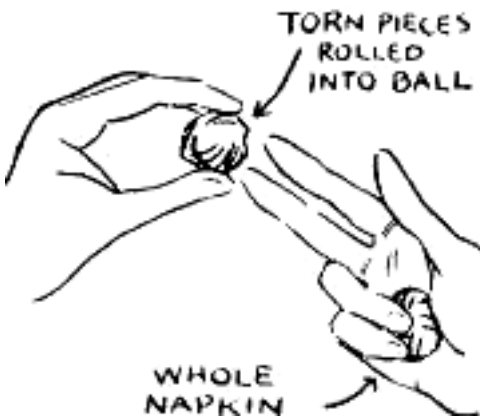


Proceed to tear napkin (cross grain is best) into a number of strips, holding each strip as torn in the left hand. As you tear each strip, continue the patter as follows:

"Two bits, three bits, four bits, five and six bits."

Then tear strips crosswise --

"And some small change which I will ball up or roll into a ball, as that would be better than balling up this experiment."

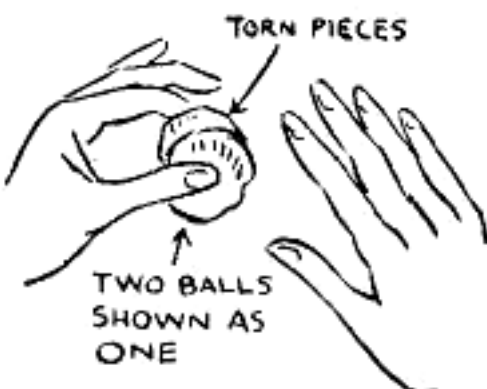


Roll pieces into small firm ball. Now comes a move that I want you to study closely as it is used to convince audience that you have only ONE napkin in your hands, when in reality you have two.

Hold ball of torn pieces between first and second fingers and thumb of left hand and ball of whole napkin in right palm.

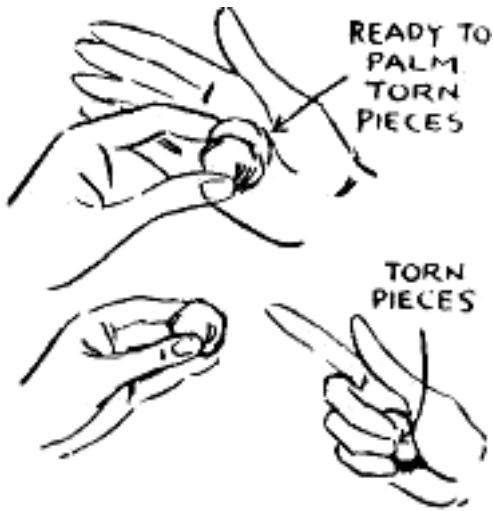


Bring the ball in left hand up to right and place it in front of ball there. Now pick up both balls with first finger and thumb of left hand so that ball of torn pieces is in front of other ball.

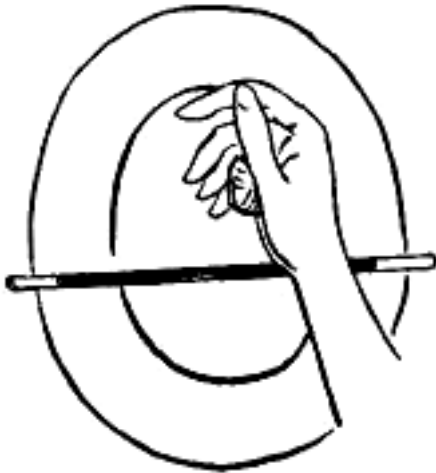


Show the two balls as one ball. When pressed together this way they do look like one ball and the audience is no wiser. Hold hands with palms toward audience so that they can see your empty palms.

"There, I have a nice tissue paper sphere with a circumference all around and a diameter through the middle."



As you say this, place right hand carelessly over balls and palm away the ball of torn pieces, which is on top. You will find this very easy to do, for as you begin to close fingers of right hand, ball automatically becomes finger palmed. When right hand is drawn away a few inches, the ball which is the whole napkin is seen by the audience. They thought you held only ONE ball in the first place and so are not aware of any change. To make the move even more natural, just after ball of torn pieces is palmed, I start pressing ball in left hand to make it a bit rounder.



Now reach over to table on your left to take pencil from hat with right hand; but JUST BEFORE DOING SO, let hand extend over pencil and a little way into hat. As you do this, drop the palmed paper ball. To the audience it looks as though you just reached for your pencil.

Take pencil. Hold end in right hand and touch other end to ball in left hand.

"It is remarkable what just the touch of a magic pencil will do."

Place pencil back over hat again.

In all these movements keep ball in left hand far enough away from body so that it is never out of sight of audience.

"I tore this Japanese napkin into strips and yet, strange as it may seem, on unrolling it (unroll napkin) we find the napkin wholly restored."

Spread napkin out and hold it so that audience can see both sides. Hands should be shown empty one at a time in holding napkin.

AN EXPLANATION (?) TO AUDIENCE OF HOW THE NAPKIN TRICK IS DONE

This is an explanation of the above effect, in which you tell your audience how you have accomplished the effect, and yet when you have finished, they find your explanation all wrong and are as much puzzled as ever.

On the table at your right you still have a napkin with a concealed ball under one corner. In your left hand you have the napkin that you have just been performing with.

"I will admit that that was a rather easy experiment. Nothing to it in reality. And if you would like to know how to do it, I will show you how so that you can fool your family, friends, enemies, relatives, or mother-in-law. First of all, the napkin is very ordinary."

Show napkin you have in left hand.

"It is just an ordinary paper napkin that you find at picnics or Sunday night supper. I really tore it up and rolled it up into a ball, but here is where the trick part comes in. Unbeknownst to you, I had another napkin rolled up and concealed here between my fingers."

Roll up napkin into ball and place in palm of left hand so that all can see it.



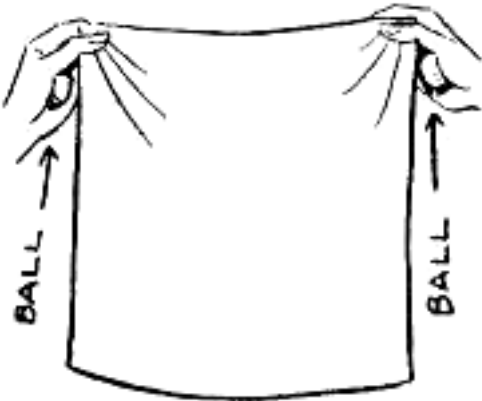
"This is how to palm an object":

Tighten up palm muscles around object which you have placed in center of palm.

You will have no difficulty in holding ball in palm. You may cover it a little with thumb if you choose.

"Or rather I should say it is concealed in my palm. I kept the back of my hand toward you, and so you thought my hand was empty."

Turn left hand so that back is toward audience and ball is concealed.



Then reach over to table on right and pick up napkin with ball of paper concealed under the corner.

Hold napkin in both hands and finger palm the ball in right hand just as you did the first time you did the trick. Audience must not know, however, that you have a ball concealed in right hand.

The trick is really now just the same as the original version except that you do it with the extra ball in palm of left hand.

"I will use this napkin on the table. Now remember, I have this napkin and the one palmed in my left hand. I tear the napkin into a number of strips -- and then crosswise again."

Tear napkin and then roll into a ball.

"Then I roll the pieces into a ball."

Do the same move here that I described to you in the preceding effect as to how to show the two balls as one.

This time hold ball from RIGHT hand and torn pieces as one in LEFT hand as in preceding effect, but remember to keep ball which you have palmed in left hand concealed from audience. Then palm off the torn pieces in right hand and reach for pencil, dropping torn napkin into hat as before.





Bring up pencil and point at the balls in left hand. The audience thinks ball between the first two fingers and thumb is the, torn napkin. Your torn pieces, however, have been disposed of. Your trick from now on is easy to do and there is nothing to detect. The audience, however, thinks the main part is yet to come.

"Using a pencil with this trick is all bunk, but it looks professional. I could have waved my handkerchief with just as much power. However in reaching for my pencil, I did something. It was to exchange the whole napkin in my palm for the torn pieces at the ends of my fingers."

As you say this slip one ball above the other by rolling the ball in back over the front one with the thumb and fingers. You may put wand under arm and show how exchange is made by using both hands.

"The single hand move shows how you do it with one hand while reaching for pencil."

"Then all I have to do is to tap the ball which is now the whole napkin, the torn pieces being in my palm, unroll the ball..."

Place pencil under right arm and unroll ball.

"And show that the napkin has been fully restored. Then you can bow as you have successfully performed the experiment."

Drop napkin on table.

"Now, the torn pieces in the left hand you can get rid of in any way that you desire. Of course, if the audience is watching you too closely, then the best way I have found is to take the torn pieces and blow gently thereon twice and pronounce the words, 'Chow Mein Chop Suey.' Surprising as it might seem, if you slowly unroll the ball of pieces..."

Unroll the ball.

"You will find that they have all joined themselves together, making a complete napkin as in the beginning. Then your audience will never know what became of the torn pieces. Don't tell them."

As a rule, it is never safe to EXPOSE a method. The less an audience knows about your method of working, the better. But in a case of this kind where you apparently expose and yet do not. you have led your audience to think that perhaps palming and using two pieces of paper is all wrong.

SUGGESTIONS:

If you prefer, you may have two napkins rolled into balls and placed in right coat pocket, together

with the two napkins which should be folded. You will find that you have no difficulty when reaching into pocket for napkin to bring out a ball concealed in palm of right hand. This method is very handy when you have to work without preparation or are so situated that you cannot arrange napkins on table without being detected.

You may also dispense with hat and pencil and use a pocket knife instead, which you can have in right trousers' pocket. In reaching for pocket knife, leave ball of torn pieces behind in pocket. You will find that this way of working makes the effect entirely impromptu.

This is a good banquet trick where paper napkins are used. During the course of the banquet, get two extra napkins. Roll them into balls and place in right coat pocket. Get knife into right trousers' pocket. Instead of a knife, a half dollar can be used. If half dollar is used, you can explain "the power of money." Merely touch ball with money. "Cross your palm with fifty cents," as the gypsy fortune teller would say.

When you start to perform, simply reach over and pick up a paper napkin from the table.

A handwritten signature in cursive script that reads "Harlan Tarbell". The signature is written in black ink on a white background.

TARBELL SYSTEM, INCORPORATED, Chicago.

LESSON 5

In your next lesson I give you three more interesting tricks with tissue paper, based on different principles.

1--A long strip of paper is torn into a number of pieces. placed in a saucer and burned to ashes. Performer shows both hands empty; then he picks up a bit of the ashes, rubs them a little, and they change to the original strip of paper again.

2--Two squares of tissue about 14 inches across are shown. One is black and the other is green. Performer tears them into a number of pieces, blows on them, and they are seen to have changed into a fancy French paper hat for milady.

3--Three bowls are shown empty. In front of each are placed three tissue paper balls -- red, white, and blue, respectively. In one bowl the three red balls are dropped one at a time, in the second bowl the three white balls are placed, while in the third bowl the three blue balls are dropped one at a time. Attention is called to the patriotic nature of the colors and to the fact that they do not remain apart very long. The bowls are turned over and instead of each containing three balls of the same color, each bowl holds a red, white, and blue ball of paper.

MAGIC AND RELIGION

"Magic was the cradle of the twin giants -- History and Science," as someone has so aptly put it. I would make it more explicit, however, and say that Magic was the cradle of History, Religion, Medicine, Pharmacy and Chemistry, and other Sciences. It was the beginning of all that we have now in the way of Science.

It seems almost incredible to us that Magic, now that we regard it only as an entertaining art, should have led the way to an understanding of nature and thus to the development of sciences. But just such was its effect. Magic, of course, you know came down hand in hand with History. In our earliest records, in Biblical times, during the Golden Age of Art in Greece, in the Dark Ages, during the Renaissance, down to the present day, we see the influence of Magic. I have already given you a glimpse of the history of its widespread influence in every age and in every land.

Now we come to the development of religion and of the sciences in relation to Magic.

Earliest Religion

Today we will take up the importance of Magic in Religion.

The earliest religion, of course, was the worship of the elements. Primitive man gazed in wonder at the sun, marveled at the rain, and was awed by day and night. In his bewilderment he conceived the idea that invisible powers were embodied in these mysterious things--the sun, the rain, the winds, etc. Because he could not understand them and because they were beyond his control, he reasoned that they were supernatural beings who ruled the world. He feared the unknown and so he feared these gods of the elements, who, he believed, caused the sun to shine when they were pleased and brought the storm when they were angered.

Origin of Magic in Religion

To these people, only self-preservation was paramount to their worship--their religion. They bent every energy to appease their gods and to keep them mollified, since even in prehistoric times there was a leader of some kind in every group or tribe of people. This leader, naturally, guided the thought and actions of the people in their religion. His suggestions, his actions--his mutterings and the waving of his arms began to signify to the people that he had some communion with the powers above. The ability to sway the will of the gods then began to be definitely associated with the leader. The people began to believe that he was an agent of the gods and thus had supernatural powers.

This marks the beginning of the relationship of Magic with Religion.

Even the cultured nations of antiquity--the ancient Greeks and Romans--believed in many gods who must be

appeased with magical practices—such as sacrificing animals and giving offerings of various kinds. The practices were performed under the leadership of the sorcerers. The Jews also, who recognized only one Creator and Ruler of the Universe, believed in powers intermediate between God and man. These powers were angels and demons who could be influenced by magical practices of humans.

The ancient priests, then, were really Magicians, and the first Magic was that which was closely related with religion.

"White" and "Black" Magic

The functions of the priest and the sorcerer were blended at first. Then as established religions were formed among nations of a higher grade, sorcerers began to practice magic and a separation became distinct between the official rites of the priests and those practiced by the sorcerers.

Here began the distinction between "White Magic" and "Black Magic." The miracles worked by the divinities under official sanction were classed as "White Magic" and were always for good. The bewitchings and administering of potions for evil by the sorcerers were classed as "Black Magic."

As religion rose to a higher level it released itself somewhat from the belief in "White Magic," and "Black Magic" grew independently of religion. Strangely enough, however, in spite of enlightenment and a philosophy of religion which developed, magic beliefs in connection with religion maintained an unbelievably strong hold—so strong, in fact, that their influence was not diminished much all through the centuries to modern times. And "Black Magic" has gained such a tremendously strong hold on peoples' imaginations that, as I have pointed out, it still exerts its influence in the form of superstitions.

Origin of Necromancy

Among the ancients, ancestor worship was a major part of religion. You can readily understand, then, how this worship of the dead and the belief that their spirits manifested themselves to the living would bring Necromancy into being. Someone had to be able to conjure up these spirits and to understand them—and, of course, this person would be the one who had supernatural powers and had communion with the deities. Thus arose the class of magicians called necromancers, which I discussed with you in Lesson 3. These necromancers aided the people in pursuing their religion through their supposed magical powers of communication with the spirit world.

Greek Oracles

The religion of the ancient Greeks was founded largely on Necromancy. Their many shrines where the oracle-gods

and the departed souls were consulted for prophecies, indicating how closely magic was bound up with their religion. The Oracle of Delphi, which was the shrine of the god Apollo, is the one especially famed in history.

And so we find that in every land, in every corner of the globe, Magic was inseparably bound up with the early religions. Today, too, in civilized countries as well as in primitive lands, these magical beliefs, though somewhat modified, are still a part of religion.

Thus we see how tremendously strong was the hold that Magic had--so strong a hold that thousands of years have failed to destroy it, and though its influence has diminished and it has been modified, Magic is still with us.

In your next lesson I will take up the subject of Magic and the Science of Medicine.

* * * * *

MAGIC DEVELOPS YOUR PERSONALITY

Personality plays an important part in Magic. It has a reciprocal relation to the Art--that is, to use a common phrase, it works both ways: Personality is developed by learning Magic and becoming a Magician, and success as a Magician depends a great deal on personality.

How Magic Develops Your Personality

Magic gives you confidence. That is a big factor in developing a strong personality -- confidence. First you must study and practice faithfully so that the presentation of your tricks may be excellent. Then you will gain confidence in your ability to present your tricks with skill and effectiveness. This confidence will be apparent to the audience and it will convey to them the impression that you have a strong, positive personality. And, indeed, this confidence will develop your personality and will enable you to make a strong impression in performing.

You know how confidence works in a social way. At a party or at a club gathering, it is always the fellow with confidence in himself who is the popular one. He is the man with "personality plus." Very often this man has developed his personality through some talent -- he may sing or play the piano, or he may be a good storyteller. Now, just think what an advantage you have over even this established favorite.

You are learning an Art which is more entertaining than any other and one which is different. If you were until now just an unnoticed member of the crowd, you can become the

popular one who is invited to every party and is well known. And all because you will have a wonderful art with which to come before any crowd. And this art gives you a distinctive personality that is always remembered.

The patter, which I give you with each trick, also helps to develop your personality. If you have been a little shy of speaking before a group, here is your opportunity to overcome any such weakness. You have something to say and you have something to do when you come before a group as a Magician. You have an opportunity to be funny, and when you see that you can make people laugh and that you can arouse their wonder and their admiration, your personality will respond and will become strong and positive.

Thus Magic brings you one of the essentials of success -- a forceful personality. You will find Magic an invaluable aid to you in developing personality in your social life, in your business or your profession, and if you plan to go on the stage the value to you of your personality in Magic will actually be measured in dollars and cents.

How Your Success as a Magician Depends on Your Personality

First impressions can make or break you. The first few moments that you are before your audience are the crucial moments. In a flash your audience decides whether they like you or not, and whether you are a Magician or not. It is vitally important that in those first few moments you sell yourself to your audience. You must get their good will right at the start.

This first impression depends on your personality and you must study the essentials which will gain for you the good will of your audience.

A person may have ability but if his personality is weak, he can never be really successful. The impression he makes on his audience is negative and he is either forgotten as soon as his performance is over or else he is remembered as a poor performer. So remember these things:

- 1 - Know your tricks perfectly.
- 2 - Be confident in your ability to present them.
- 3 - Give your patter in a strong, forceful manner.
- 4 - Try to maintain always a natural manner.

To sum it all up --

You must have a strong personality to be a success at Magic.

Magic helps you to develop the personality which success at Magic requires.

LESSON 5

In the last lesson you were initiated into paper tearing effects. Effects of this kind are very useful on any program. I hope that you have mastered the moves for I want you to feel perfectly familiar with them.

In this lesson we will continue with tissue paper effects.

HINDOO PAPER TEARING

This is another variation of the torn and restored paper effect with a different way of handling the thumb tip and of getting rid of the extra piece of paper.

EFFECT:

A strip of colored tissue paper about 30 inches long and 1 inch wide is carefully shown, then torn into a number of small pieces, which are placed in a saucer and burned. The performer shows hands empty, then reaches into the ashes and with the tip of his first finger and thumb of right hand takes a pinch of the ashes. A few magic words and the bits of ashes change to the strip of paper, which is unfolded and shown to be restored.

PARAPHERNALIA:

1--Two strips of colored tissue paper, preferably bright colored, about 30 inches long and 1 inch wide.

2--Thumb Tip.

3--A saucer or little brass dish.

4--Small box of matches.

SECRET AND PATTERN:

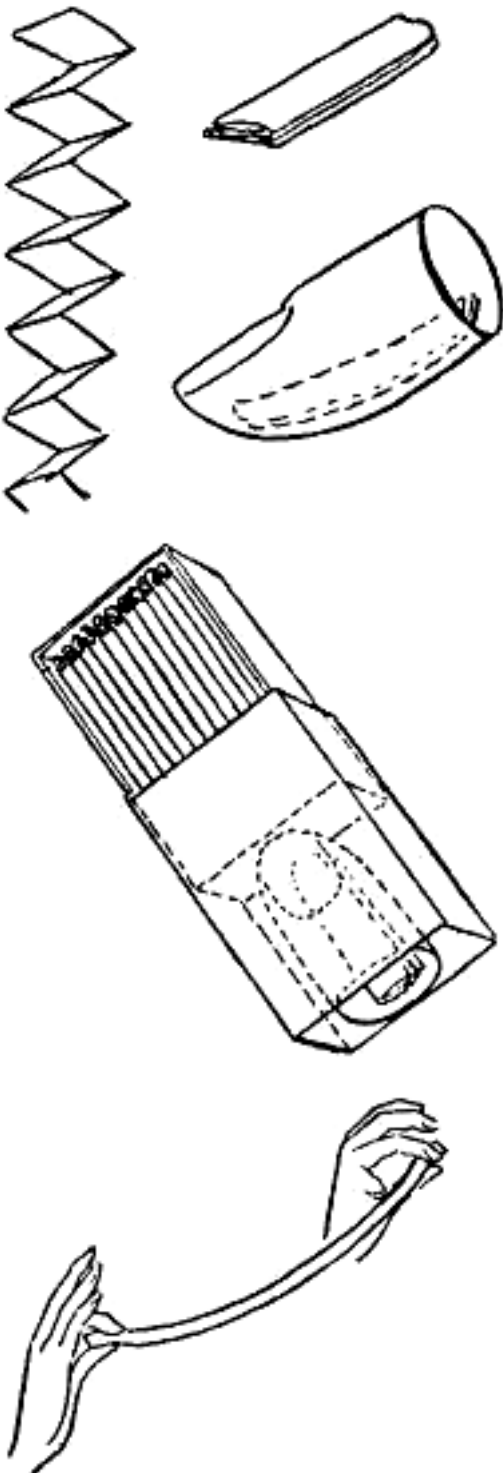
To Prepare:

Fold or rather pleat the strip of paper down small and place in thumb tip. Push thumb tip, containing paper, into match box cover. This forces the box of matches out a little over half way. Tip should be completely hidden in cover so that a spectator looking directly down on box could not see it.

Have box prepared with thumb tip and paper on a table, end of box with tip away from audience. Have a strip of paper and a saucer or little brass dish near box.

Pick up strip of paper from table. Hold one end with left hand and other with right hand, letting audience see palms of hands. Show paper freely on both sides.

"You have no doubt, heard some very interesting stories about the Hindoo Yogis. For ages these Yogis have been known



for their philosophies and occult teachings. I remember one Hindoo teacher who used to teach philosophy with some interesting material illustrations. He would, for instance, take a strip of paper such I have here and tear it into many small pieces, . . . "

Tear strip into a number of pieces.

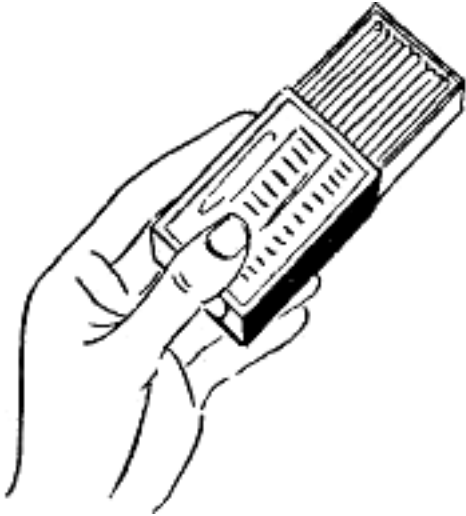
"Which he would place in a small dish."

Show saucer to be empty and unprepared.

"Would you, sir, kindly examine this little dish and hold it for me?"

Give dish to spectator to hold.

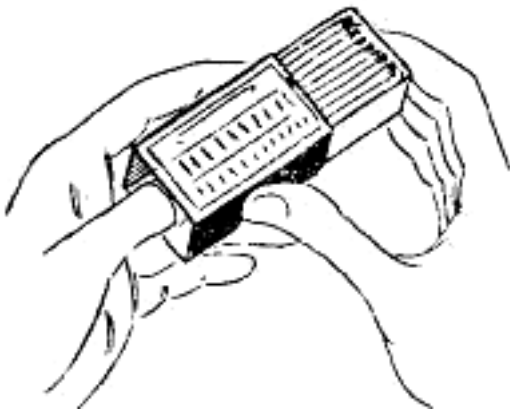
"Now, let me just place these many torn pieces into the saucer. Are you quite certain that the paper has been torn and that the pieces are really in the little dish? You are certain."



Pick up match-box from table with right hand and transfer it to left hand in position shown in illustration.

Take out a match with right hand, strike it on side of box, and light torn pieces of paper.

"How frail life is - a beautiful thing at one moment and ashes the next. There! The tissue pieces have turned to ashes."



PLACE LEFT THUMB INTO TIP.



Close box of matches with right hand. This automatically forces tip out of cover. You now have Tip on thumb, end of it facing audience. Drop match-box on table with right hand.

"But here is where the Hindoo teacher taught his philosophy of life. He would show his left hand containing nothing."

Show left hand for a second, thumb tip towards audience. Then drop hand a bit, concealing tip behind fingers.

"And with his empty right hand he would take up a pinch of ashes."

Show right hand so that all are convinced that it contains nothing. Then with first finger and thumb reach into saucer and take a pinch of ashes.

"See -- one needs but a pinch of ashes."

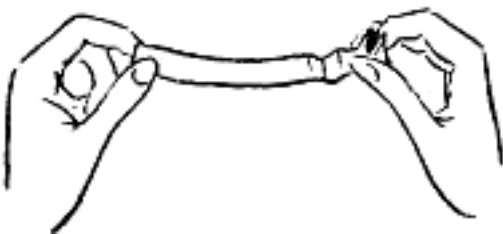
As you show ashes, hold up both hands for a second with thumbs pointing toward audience. Look at ashes and as you do so, close left fist around thumb tip. Finger palm tip and allow thumb to come out.

"Then one rubs them a moment with both hands."



Bring hands together, and with right index finger take strip of paper from thumb tip.

"And under the warmth of human touch we find the ashes materializing into the paper strip again."

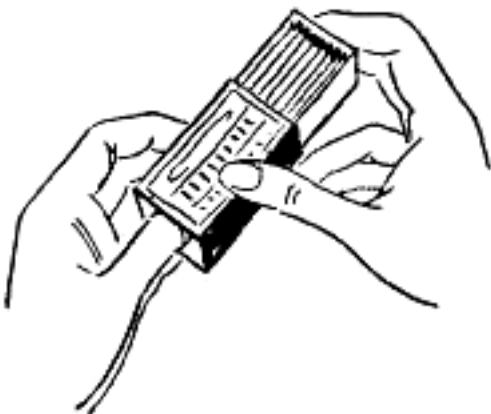


Unfold paper. Then hold it at each end and show both sides.

"According to the Hindoo philosopher, nothing can be destroyed. Every deed we do is registered in the great scheme of things. Life is constantly changing. Form transfers itself into other forms, but matter is never destroyed. The tissue that was turned to ashes has changed back to tissue again, proving that the Hindoo was right and that in the final analysis nothing can be destroyed."

Let paper fall on table. As paper falls, bring thumb into tip again. Show both hands for a moment and drop them again.

Get rid of tip by placing box of matches or strip of paper into pocket or by reaching into pocket for some article for next effect.



NOTE:

You will find that in some experiments the match-box is valuable for getting rid of the thumb tip as well as for producing it.

Tip is on left thumb. Pick up match-box with right hand, transfer to left, push drawer out with left thumb. Tip goes into box and forces box open. Leave tip in cover and remove thumb. Take match from box and use it for some purpose -- to light a candle or cigarette. Tip fits snugly into matchbox cover so that box can be placed on table, keeping end with tip away from audience.

ANOTHER METHOD OF PERFORMING HINDOO PAPER TEARING EFFECT:

This effect looks the same to the audience, but the method of handling thumb tip is somewhat different.

Have box of matches, strip of paper and saucer on table. Thumb tip with duplicate strip of paper is on left thumb.

Show hands empty. Pick up strip of paper with right hand. Finger palm tip in left hand. Show strip freely and tear it into small pieces. Hold torn pieces with first finger and thumb of left hand. Pick up dish with right hand and give it to spectator. Transfer torn pieces to right hand and place them in saucer.

Pick up match-box. Light paper or have spectator light it. Pick up pinch of ashes with right hand. Manipulate tip back onto left thumb, showing palms of hands empty.

Finger palm tip again, bring hands together, pretending to rub ashes. Take strip from tip with first finger of right hand and show paper freely. Roll paper up into ball and place in pocket, leaving tip with it.

You can begin to see now why it is so necessary to learn a principle and the way of handling a piece of apparatus well.

I explained to you in Lesson 2 the Thumb Tip Manipulation Principle and gave you four effects with the tip. Today I gave you another effect using the tip, and as we go along, you will find more and more use for it.

Keep your tip in good condition. If it shines too much, a good temporary duller is to rub it with a soft pencil eraser. It will have to be painted with dull drying Japan paint occasionally, according to directions given you in Lesson 2. Be careful to paint the tip as near your skin color as possible. You will have to experiment to get the right shade for your skin. It is well worth the trouble for it will make your thumb tip as nearly indetectable as possible.

MILADY'S PARISIENNE HAT

In this effect you have a chance to show your ability as a milliner. It is another version of the Torn and Restored Paper Effect and is an excellent trick for an audience which has women in it.

Every magician must know how to construct his own paraphernalia. He must know how to do this for several reasons: First, the paraphernalia he needs may not be available at the time he needs it and if he knows how to make his

own, he need not depend on anyone else; Second, because of the secrecy of methods, he is able to keep his secret to himself by making his own paraphernalia; and Third, making his own paraphernalia leads to originality and inventiveness on the part of the magician. And I hope some day to see you making original effects of your own.

With this effect I teach you a little constructive work to start you in the fascinating work of making your own paraphernalia.

EFFECT:

Magician shows two sheets of tissue paper on both sides. He places them together and tears them into a number of pieces. Then he folds the pieces into a small wad. The paper is opened and is found to have been transformed into a French tissue paper hat, which Magician places on his head or on the head of a lady in the audience.

SECRET AND PATTERN:

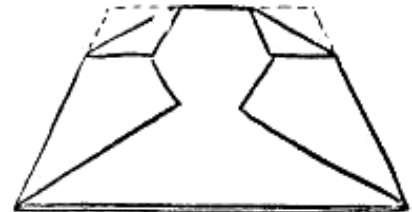
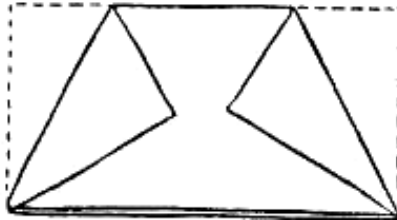
To Prepare:

Here I will teach you how to construct the paper hat.

Materials you will need are:

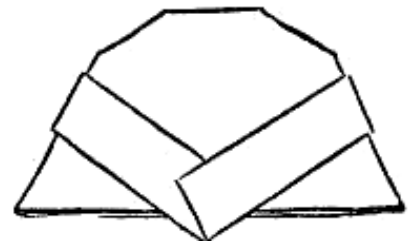
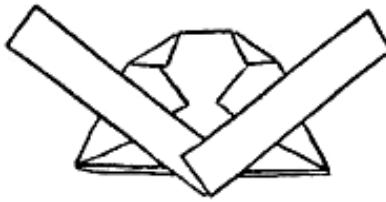
Tube of glue or good paste, pair of scissors, piece of black tissue paper, 15 inches square, two strips of green tissue, each 2 3/4 inches wide and 14 inches long.

Take the square of black tissue paper.



Fold paper over in half. Fold both sides over and paste down. Fold over top corners and paste down.

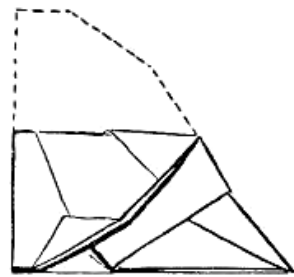
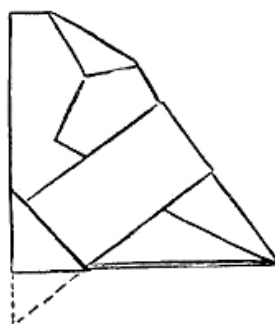
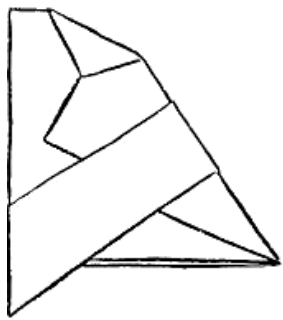
Take strip of green tissue.



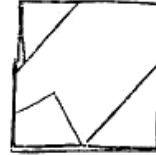
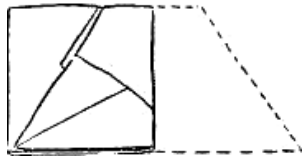
Paste strip on black tissue as shown above.

Paste other strip on opposite side. Turn hat over. Fold both strips over to this side and paste down.

When dry, hat is ready to be folded for trick.



Fold in half. Fold green flap up at bottom. Fold top down.

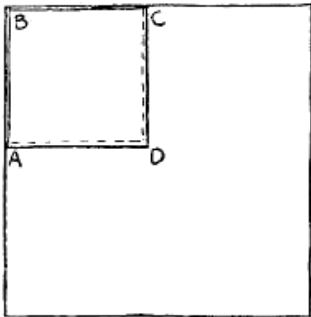


Fold over right to left side Turn paper over.

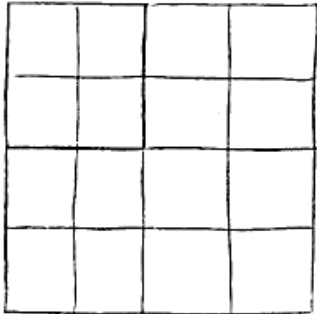
You now have the hat folded into a square about 3 5/8 inches each way.

We proceed now with the rest of the preparation for the trick:

Take a piece of black tissue paper, 15 inches square, and a piece of black tissue 6 1/2 inches square.



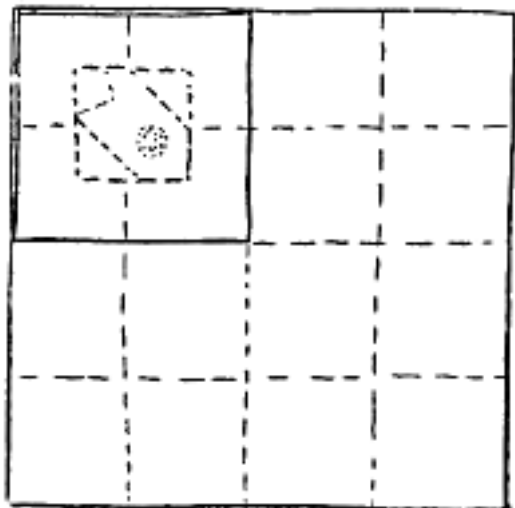
Put some paste on the inside two edges of the small square -- AD and CD. Then place small square carefully on large square and press down pasted edges. This makes a large square of tissue with a pocket. The sides AB and BC are open.



When all pasted parts have dried, fold square of paper into small squares. This is done to keep the edges of the pocket from being noticeable.



Take the hat, which you have folded into a small square, and put a spot of paste, about an inch, at point indicated in illustration.



Open up pocket on large square of tissue and slip in folded hat as shown in illustration. Press down on pocket and hold until paste holds well. Set aside until dry.

Hold paper up by outer corner of pocket. Be careful to hold outer edges of pocket and those of large square together. You can show both sides of square quickly. It looks just like an unprepared black paper napkin.

Take a sheet of green tissue, same color as band used in making hat. Cut a sheet 15 inches square (same size as black sheet).

Place green and black sheets together and fold green in squares as you did with black sheet.

Put sheets on table, green on top. You are now ready to perform.

Pick up the two sheets of paper. Hold them up with the green sheet in front of the black one. Hold them at the corner in which the hat is concealed.

"Have you ever heard of French tissue paper millinery? It seems to be very popular in Paris. I was visiting some friends there and I was surprised at the number of new hats my hostess wore - green ones, pink ones, black, blue, lavender ones. 'Your hat bill must be very high,' I said to her one day. 'What makes you think that?' she asked. 'Well,' I replied, 'I am judging from the number of new hats you have.' She laughed and said it was evident that I did not understand the Parisienne art of tissue paper millinery. 'You see,' she said, 'We ladies make our own hats and thus make use of our artistic sense. For instance, here are two sheets of tissue paper - black and green'"

Show papers -- first the green sheet, then the black one for a second, then back to the green one.



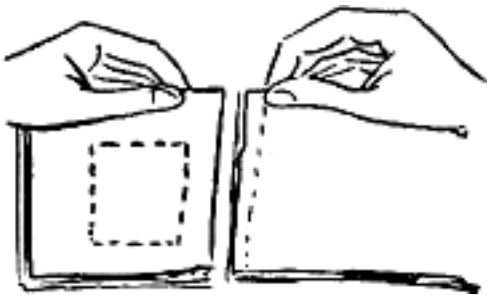
Now separate papers and hold black in right hand by corner with pocket and green in left hand. Turn hands quickly and show papers both sides. Then bring papers together again with green sheet in front.

The audience think they have seen just two plain sheets of paper. You must try to keep the edges of the pocket together. However, with the quick turns of the paper, the pocket will not be noticeable to the audience anyway.

"Now watch me tear the papers into a number of pieces. Instead of cutting patterns with scissors, I tear them."

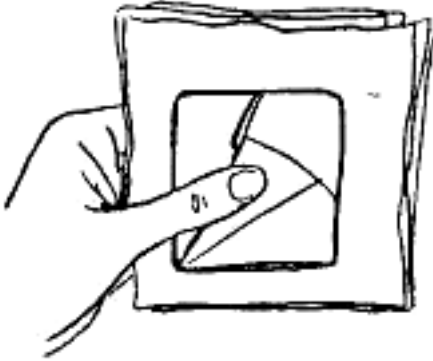


Hold Pocket Corner with left hand. Tear through green and black paper tearing about half an inch off pocket. Then tear one more strip through both sheets.



Now turn paper sideways. Tear through, tearing about half an inch off pocket, then tear once again. In tearing, each time place the torn pieces in front of each other. You now have a bunch of square pieces of tissue, all in front of the back pocket concealing hat.

These pieces can be shown on both sides as rear piece of black pocket prevents audience from seeing folded hat.



Then place rear black piece in front. The folded hat is now behind the torn pieces, just as the ball of paper was in the Chinese Paper Trick in Lesson 4.



Fold and crumple torn pieces into a loose ball or flower effect.

"Then I fold them over and give them a tuck here and there and open some of the pieces up."

Begin opening up the folded hat.

"Until I find a beautiful Parisienne hat."



Open hat out in full and place on your head or on the head of a lady assistant or lady spectator.

You will see that the ball of torn pieces forms the pom-pom or flower on front side of hat.

"And Hubby certainly could never kick about the expense of such a millinery bill."

THE PATRIOTIC PAPER BALLS

A very pretty experiment that is easy to perform. It gives you one or two moves in sleight of hand.

EFFECT:

Three bowls are shown empty and placed in a row about six inches apart on the table. In front of each bowl Magician places three tissue paper balls—red balls in front of one bowl, white balls in front of second bowl, and blue balls in front of third bowl. He drops the three red balls one by one into the first bowl; then the white balls in the same

manner into the middle bowl; and finally the blue balls into the third bowl. Magician calls attention to the patriotic nature of the colors—this being the reason that the balls cannot be kept apart. He turns the bowls over and instead of three balls of the same color in each bowl, we see red, white, and blue balls in each bowl.

PARAPHERNALIA:

1--Three bowls, preferably deep like soup bowls.

2--Three red tissue paper balls. Three white tissue paper balls. Three blue tissue paper balls.

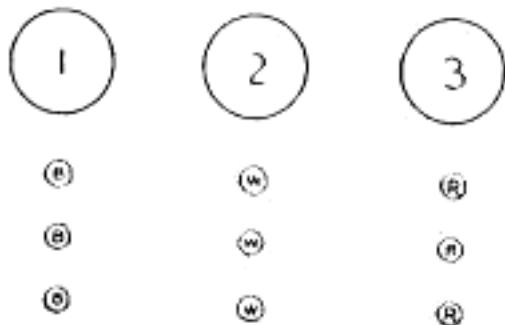
Balls should be made in this way:

For each ball take a piece of tissue six or seven inches square.

Fold all four corners of the paper in a little beyond center of sheet. Then keep on folding in corners until you have a ball tightly pressed together so that it will not spring open very much. Ball should be about 3/4 inch in diameter.

SECRET AND PATTERN:

TO PREPARE: Have the three bowls stacked inside of each other. In the top one have the nine balls of paper. These bowls may be all ready on the table or may be brought in and placed there for the experiment.



Separate the bowls and throw balls on table. Show bowls empty, one at a time, and place them in a row on the table, about six inches apart. In front of the bowl on the left side (1) place the three blue balls in a row about 2 1/2 inches apart. In front of the middle bowl (2) place the three white balls. In front of the bowl on right side (3) place the red balls. Study illustration carefully for arrangement of bowls and paper.

"When you have looked at our American flag, I wonder whether you have ever thought why the colors, red, white and blue, were used instead of green, black and pink, or purple orange and lavender. It is because of the patriotic nature of red, white and blue and the inseparable bond of harmony between them. I can perhaps explain it better with a few objects which I have here—three bowls and three red, three white and three blue tissue paper balls. Bowl 1 is empty and I will set it here. Bowl 2 is empty and I will place it nearby. Bowl 3 is also empty and I place it here."

Show the bowls one at a time as you say this, and place them in their positions.

"In front of each bowl I shall place three balls. In front of Bowl 3—these three red balls."

Place three red balls in a row in front of Bowl 3.

"In front of Bowl 2--three white balls."

Place three white balls in row in front of Bowl 2.

"In front of Bowl 1--three blue ones."

Place three blue balls in front of Bowl 1.

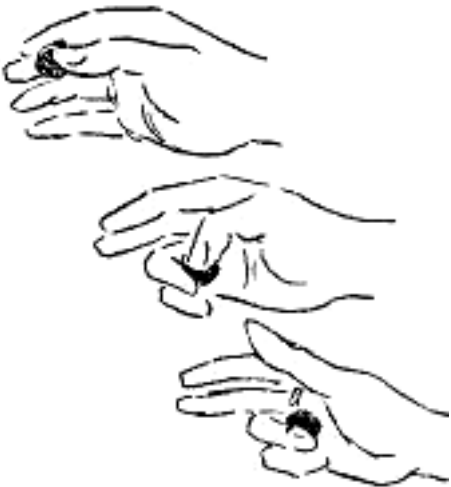
"I will place each color, one at a time, in their respective bowls. In Bowl 3, this red ball."



Show right hand empty and pick up red ball between first and second fingers and thumb. Pretend to put it into Bowl 3. Audience thinks you do put it in, but this is what you really do--move ball down from first and second finger with thumb to middle of third finger and curve third and fourth fingers inward to FINGER PALM the ball. You will find the movement easy with a little practice. Back of hand is toward audience throughout most of experiment.

Then pick up white ball and hold with thumb and index finger of right hand, while red ball is still finger palmed.

"In Bowl 2, this white ball."



You pretend to put white ball into Bowl 2, but this is what you really do. You drop RED ball into Bowl 2. Then you bring White ball down with the thumb of right hand from first and second finger tips to middle of third finger and finger palm the White ball as you did the Red one originally. You now have your first and second fingers and thumb free to pick up another ball.

Through most of the experiment these moves are the same:

PICK UP BALL

FINGER PALM

DROP

"In Bowl 1, a blue one."

Pick up blue ball and drop white.

"I'll place this red ball in with the other red one..."

Pick up red ball, drop blue.

"This blue ball with the other blue one..."

Pick up blue, drop red.

You will note that I jumped the white ball, but it was done with a purpose.

"This white ball with the other white one..."

Pick up white ball and drop blue.

"Let the remaining red ball keep company with the other two red ones..."

Pick up red ball and DROP BOTH RED AND WHITE BALLS into Bowl 3.

"The white ball with his other white friends..."

NOTE THIS MOVE. As you pick up white ball, turn right hand over casually so that audience can see palm of hand. Instead of placing hand into bowl as you did with other balls, drop this white ball from a height about three inches above Bowl 2, so that audience sees it go in.

WHY DO WE DO THIS? It is such moves which make Magic. When we get a chance to accent a point to convey a certain impression to the audience, we stress that point.

We wanted the audience to believe that we had placed the balls one by one in their respective bowls so that three of each color were in each bowl, respectively. We did not do this with seven of the balls, but now with the last two-- a white one and a blue one--we have a chance to show that we are actually dropping the white ball into Bowl 2 and the blue ball into Bowl 1. The fact that we show the audience that we actually drop these balls into their respective bowls, accents the fact that the others were fairly done.

"And last, but not least, the blue one we shall place with the Blue Brothers."

Put blue one in with a toss, which makes a good finish.

"Let us summarize the situation. What have we? In Bowl 3, three red balls; in Bowl 2, three white balls, and in Bowl 1, three blue balls. But if you were standing where I am, you would see something peculiar happening. They are moving about in a mysterious manner. Well--look at that little red fellow go."

You are looking into bowls and pretending to see this.

"Now I will show you what I mean by patriotic colors and why we use red, white and blue in the flag. I turn over Bowl 3. Look! A red, a white and a blue ball. In Bowl 2--a red, a white and a blue ball. In Bowl 1--a red, a white and a blue ball."

As you say this, turn over each bowl, one at a time, and show the three balls. Pour them out into right hand, then let them drop on table.

"Patriotic? I'll say they're patriotic. You can't keep them apart."

* * * * *



In order to impress on your mind the ROUTINE of dropping the balls, study this chart and keep diagram well in mind.



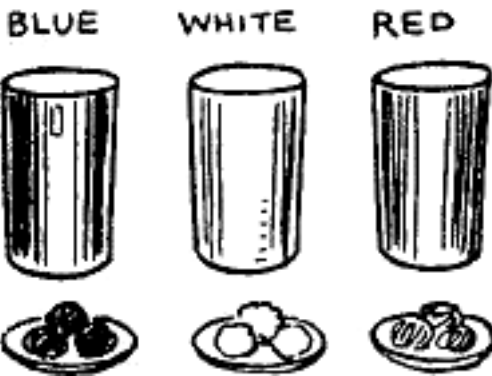
SUGGESTIONS:

For performing on the stage or in club work, I vary the presentation of the experiment. Instead of placing the balls in a row in front of the bowls, I place the balls of each color in a saucer so that they can be seen. They cannot be seen when lying in a row flat on table.



If you will use a red bowl, a white bowl, and a blue bowl and in front of each have a similar colored saucer, and then place the balls of like color on each saucer, you will have a very effective means of presentation.

Be careful that during progress of trick no one can see into bowls to discover colors of balls in each.



I find it very handy to use opaque glasses, such as are used in bathrooms. They are deep and hard to see into. They are exceptionally satisfactory for close work. Sometimes I take ordinary tumblers and cover them with paper-- one red, one white, and the third blue.

To vary the effect, instead of using paper balls, use three onions, three small potatoes, and three radishes. Invent patter to fit the combination.

LESSON 6

In your next lesson I am going to give you some very interesting effects with a piece of string or cord.

1--Kellar's famous cut and restored cord trick, with which this famous illusionist baffled many magicians. A piece of wrapping cord is cut in half by a spectator and the two pieces of string held apart. Two ends of the cord are tied together and lo! the knot disappears and the string is in one piece again.

2--Another version of the Kellar Cord Effect, introducing you to Comedy Magic. Excellent comedy patter.

3--An impromptu cut and restored cord effect. This is an astonishing effect done without any preparation. A piece of string or cord is cut by spectator and then restored by magician.

MAGIC AND THE SCIENCE OF MEDICINE

I have given you in previous lessons some of the History of Magic and Magic's Relation to Religion. Now I shall trace for you Magic's relation to the great science of Medicine.

The Art of Medicine today with its profound studies of human ills is a far cry from the elementary medicine practiced by Magicians of old and still practiced by barbaric tribes. Yet this great and highly developed art had its origin in the crude practices of ancient magicians.

Origin of the Art of Healing

The most primitive method of treating disease was the use of spells and incantations by the magician. Then came the use of stones, sticks, and strings to draw out diseases. And later began the use of some practical remedies in combination with magical remedies. Essences and elixirs and ointments made from herbs and barks were administered by the magician. But with these remedies were still required the magical formulae which dealt with the demon-cause of the ailment. These herbs, though many are now used by Pharmaceutical and Medical Science, in ancient times were chosen for magical rather than for medicinal reasons.

Inseparably Bound Up With Magic

Among the Chinese, the head of a plant was used to cure the head of the patient, the middle of the plant was used to cure the body of the patient, and the roots were used to cure the patient's legs. In the same way European doctors practiced what is known as "doctrines of signatures." This was, in fact, mere magic. They prescribed "eye-bright," a flower with the likeness of an eye in it, for complaints of the eyes. They treated small-pox with mulberries because their color made them proper for diseases of the blood. Thus magic and medicine were equally important in the infancy of the treatment of disease. These magical practices clung to the Science of Medicine just as Magic maintained its strong hold on Religion.

Magic Influence of Planets

A definite system of relationship between the planets and medical art was devised by the ancients and this system was one of the main foundation stones in the development of the Art of Medicine. The influence of this system was apparent up to modern times, and in many foreign lands it still holds sway to some extent. By this system the human body was divided into sections which were under the power of certain planets.

Each planet was designated as capable of causing or curing certain diseases. These beliefs, of course, began with the art of divination and then became amalgamated with the primitive art of healing.

A table was worked out in which was stated the plants and herbs that were connected with each planet and the hour during which these should be prepared. The time which was auspicious for administering medicines and for performing operations was also recorded. Thus the "doctor" or sorcerer could consult his table and therein find the treatment for his patient. If the results of the treatment were harmful or even fatal, the sorcerer was absolved from blame because the people believed that the planets were at fault, not the doctor. Even in more modern times, in the 17th and 18th centuries, a doctor might lose case after case and yet he was not condemned for it was believed, not that he did not know his art, but that the planets were inauspicious.

Methods of Earliest Doctors

This is the system of diagnosis and treatment used by the sorcerers, who were the first doctors. When a man became ill, the first thing to do was to discover the nature of his disease by means of the planets. If the moon was in a certain relation to Saturn at the time, for instance, it indicated that the man had a headache and cough. This was the diagnosis. Then the herbs which would be effective under these conditions of the moon and Saturn and the ailment of the man were studied. With this determined, the hour at which the medicine must be administered was found according to the planetary system. And thus the treatment of the ailment was arrived at. So we see that the art of the earliest doctors was much magic and a little medicine.

Mystic Charms and Signs Used

Talismans and charms with pictures and insignia of the planets on them were used also by the sorcerers in addition to the herbs and plants and minerals which the planets governed. Mystic characters and signs were an inseparable part of early medical practices. A circle was believed to have great influence in curing disease. The origin of this seems to have been in primitive sun worship. Certain numbers had great significance also in effecting cures. A combination of the numbers and signs sometimes was the whole treatment for some diseases. Consumption, for instance, was treated by passing the patient through a circular wreath of woodbine three times. This woodbine had to be cut during the increase of the March moon.

Some sorcerers cured their patients in this manner: They took a garland of green woodbine and caused the patient to pass through it three times. The garland was then cut into nine pieces and cast into the fire. This was a sure cure. Whooping cough was believed to be cured by giving the patient a certain draught to drink from the horn of a living ox, nine times repeated. All draughts and ointments, of course, had to be prepared according to the hour when certain planets were ruling.

These magical practices in connection with the Art of Healing were used for centuries up to modern times. With the enlightenment of the ages, medicine has been gradually releasing itself little by little from the influence of magic.

Magic a Great Aid in Business

I have told you how Magic will develop your personality socially. The importance of personality in the social world is great because being well known and well liked means so much in your happiness. Think, however, of the tremendous significance of personality in business. You know that it's the man with personality who gets ahead every time.

You Make Lasting Impression

As Magic develops your personality you find that you are progressing in your business. With the training in Magic which you have, you are better able to meet people. You have a little trick with which to break the ice when you call on a customer. In this way you can get the interest and attention of the man you are after. And you leave with him a lasting impression for he will remember you as the man who is clever at tricks. This business man becomes your friend because you arouse his interest in you as a personality. Your Magic has helped you win this man as a business friend and through him you meet other men either in a business or a social way. However, magic, like everything else, has its proper place and should be used with intelligence.

Invaluable to Traveling Salesmen

Magic has been proved to be invaluable to traveling salesmen. If he knows the Mystery of the Burning Cigarette, for instance, he has right there in that trick a powerful means of getting the prospective customer's interest. He calls on his man and starts talking business. At a proper moment he asks the man to loan him his lighted cigarette as seeing the man smoke reminds him of a little trick which he would like to show him. He performs this wonderfully puzzling little trick and he has his prospect smiling and good natured and interested. Then when he gets back to business, he has the good will of his prospect and can very probably make the sale.

I have heard that one of the salesmen for Maytag Washing Machines is using Magic to aid him in his sales with remarkable results.

Magic a Wonderful Hobby

If you aim to go on the stage or if you plan to become a semi-professional magician to make money on the side, you will have to study and practice principles and fundamentals and

moves and tricks for a while yet before you will be proficient and will have a wide enough repertoire to accomplish your aim.

All of you, however--those who have ambitions of making money with their magic, those who want magic to bring them social popularity, and those who want magic to help them in their business--can start now with Magic as your Hobby. I am sure you realize by now what a wonderful means for relaxation from your daily work you have in Magic and what a fascinating additional interest in life you gain in studying the art.

Men in every field of business and professions--doctors, lawyers, salesmen, artists, men in every kind of business-- have taken up Magic as a Hobby and found rich rewards in having a fascinating and distinctive art.

LESSON 6

In this lesson we study cut and restored cord effects. I give you THREE good methods for this part of Magic. I could give you just one way of getting these effects, but let me say again, I want you to be prepared for emergencies so that when it is not convenient to use one method, you may use another. Remember that what I am training you in is the foundation of magic--the underlying principles. From these principles I hope that some day you will build original combinations and make a name for yourself through your Individuality. First, however, you must be well grounded. I cannot teach you your individuality--that you must develop for yourself--but I do want to give you tools to work with.

KELLAR'S CUT AND RESTORED CORD

Harry Kellar was a great magician. He ranked among the world's best. A masterpiece in his hands was a cut and restored cord trick that baffled even magicians. Kellar died some time ago, but his cord effect lives on. I give it to you here.

EFFECT:

A piece of wrapping cord about 30 inches long is shown and cut in half by a member of the audience. Performer holds the two pieces far apart to show that the cord has been actually cut into two pieces. Magician then takes two ends, ties them together, and in a moment the cord is restored into one piece again.

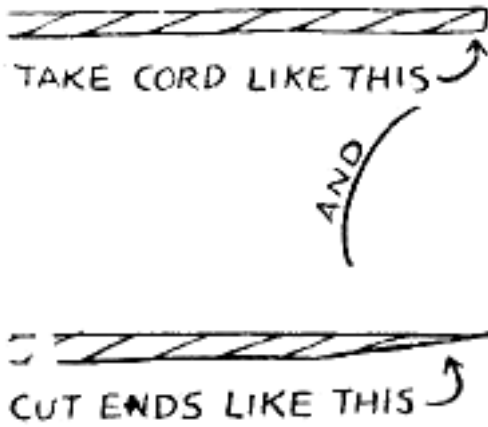
PARAPHERNALIA:

1--A piece of ordinary tightly wound wrapping cord, a sample of which we sent you with your box of apparatus. This cord may be purchased at any hardware or department store.

2--A piece of magician's wax, a box of which we have also sent you.

3--A pair of sharp scissors. I usually carry a pair of blunt end scissors in my pocket.

SECRET AND PATTERN:



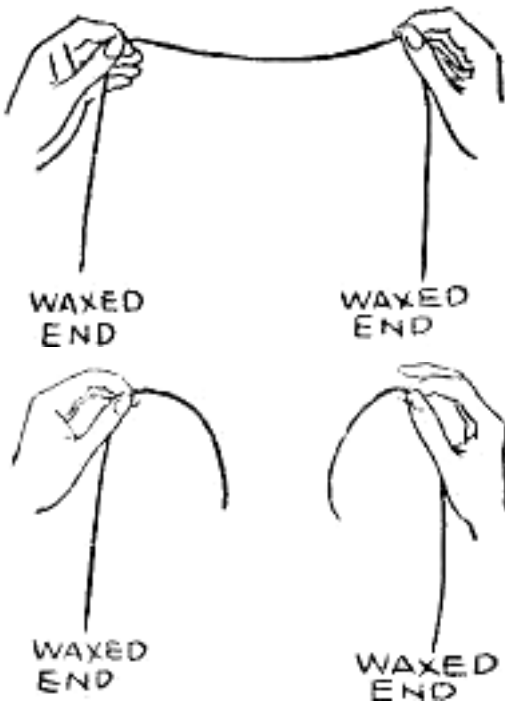
To Prepare:

Take the piece of cord. With a sharp knife or scissors taper the ends of the cord off into a point. Now take a little of the wax out of the box with your finger nail, and wax ends well. To see whether you have done this properly, take the two ends and hold them together. Roll them and press them until they stick together and string looks like one piece. If this has been done right, the keenest eye at a short distance away cannot see where the joining was made. Pull ends apart, smooth them down to a perfect taper on each one, and you are ready to perform.

Like many other GOOD effects, this one has a SIMPLE modus operandi.

Show cord freely. Take scissors and hand them to a spectator.

"For this experiment I want to show you a masterpiece formerly performed by a great magician--Harry Kellar. Kellar, as you no doubt all know, was one of the greatest magicians of his time. Some people say that Kellar got the idea for this experiment when he saw a Hindu magician, sitting in the street somewhere in India and performing to a crowd of tourists, do mysterious and bewildering things with a piece of string. But however that was, I have been very lucky to obtain Kellar's great effect and now take pleasure in showing it to you."



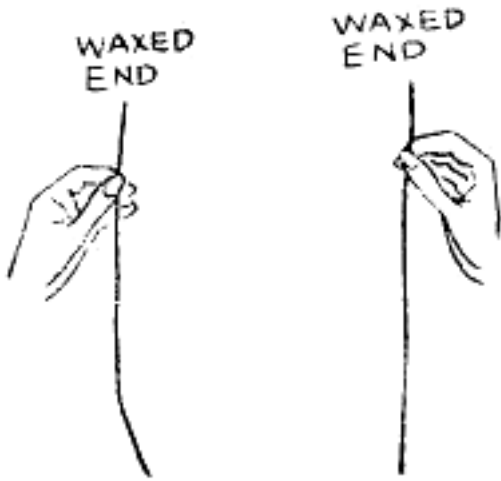
Hold cord up between your hands.

"Kellar used just an ordinary piece of wrapping cord such as I have here. Sometimes he would just cut a piece of cord from a package at hand. Now, sir, will you please take the scissors and cut this cord through the middle?"

Spectator cuts cord in half. Bring your hands farther apart to show that cord was cut.

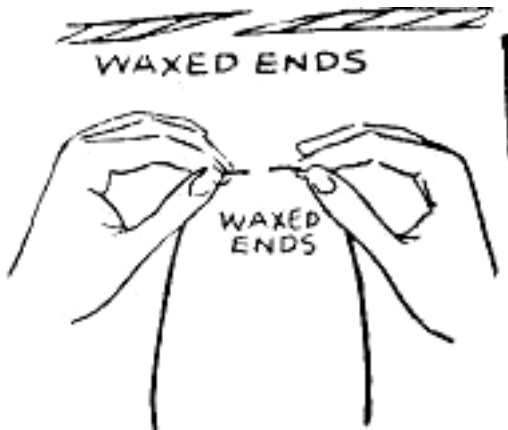
"You are quite certain, sir, that you cut the cord in two and that it is now in two pieces?"

(6-5)

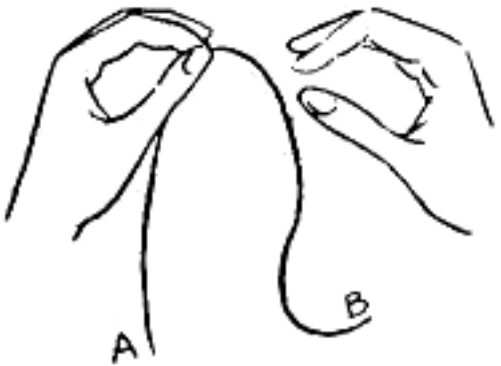


Turn to audience, and as you do so, reverse cords so that waxed ends, which have before been hanging down, are now at the top.

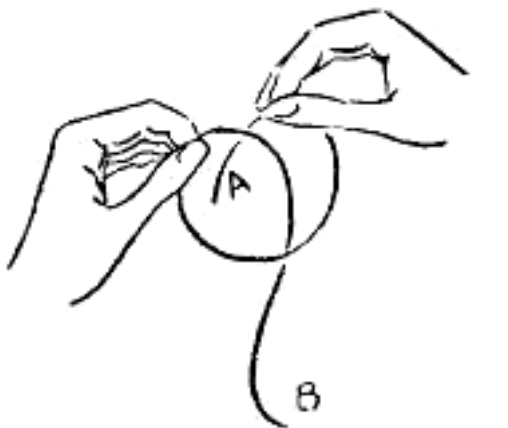
"And you are also quite certain, are you, that the cord has been cut in two? All right then, watch."



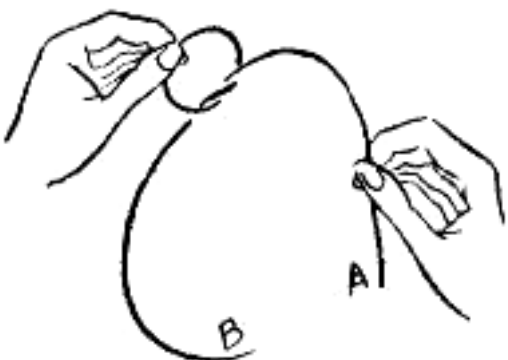
Bring the two waxed ends together, overlap them, and hold both ends between thumb and first and second fingers of left hand.



Press waxed ends together and roll them a little between fingers and thumb of left hand so as to make the joining the same diameter as the rest of the cord.

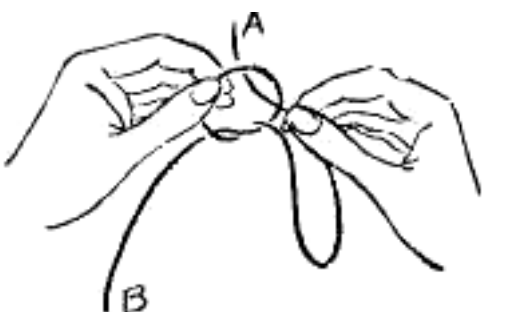


While doing this, to help distract attention from the left hand, take End A of cord, loop it through near middle of cord.

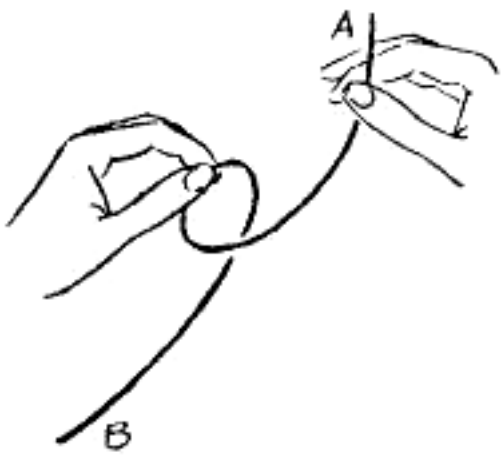


Pull End A through and tie a single loop knot in cord.

"Kellar would take an end of the cord, bring it up and pass it under and through this way to make a loop. Then he would take the end and push it through the loop again with the result that the knot became untied."



Take End A with right hand and push it back through the loop. This, of course, unties the knot.



Hold End A up with right hand as shown in illustration.

(6-6)

"This movement, of course, caused the cord to come back again into one piece."



Drop cord from left hand and let it hang from right hand. Show palms freely as well as restored cord. It looks as though the cord were actually restored if the joining has been done properly, and it will fool the closest watchers.

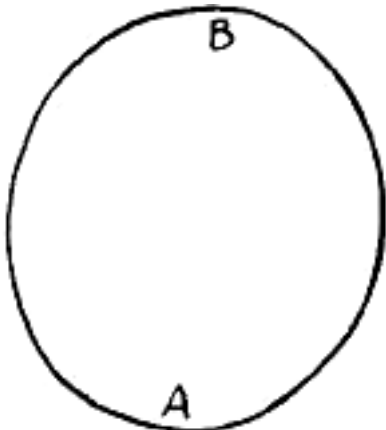
"And there it is just as good as new and ready to tie a package with again."

Roll cord up loosely and place in pocket. Sometimes I have a duplicate cord in my pocket. As I put my hand in my pocket to leave cord, I exchange cords. Then I bring out the new cord to start a new trick with, such as the ring off the string, etc. The audience thinks I use the same cord which I had just restored. Or sometimes I take the whole cord out of my pocket later and toss it carelessly away, where some inquisitive one is sure to find it later. When he finds an ordinary piece of cord undamaged in any way, he is thoroughly puzzled.

COMEDY VERSION OF GERMAINE CORD EFFECT

EFFECT:

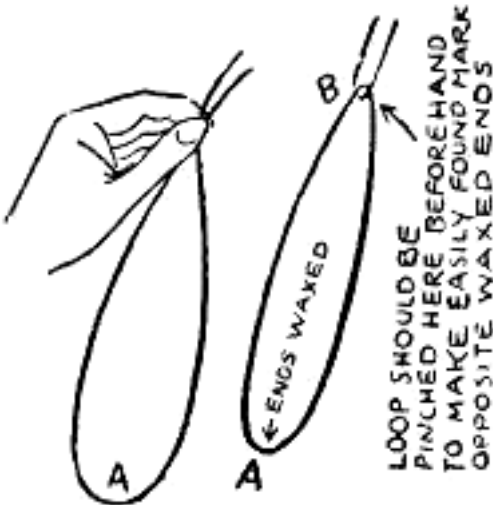
This is a popular method of Karl Germaine's and is similar to the Kellar effect except that cord is tied together at first to form a loop. Center of looped string is cut, tied together and restored in a mysterious manner.



CORD WAXED TOGETHER HERE

To Prepare:

Take a piece of cord as in the first effect. Taper the ends and wax them. Then bring these ends together and press and roll them together until they make an unnoticeable joining. You now have a loop of string.

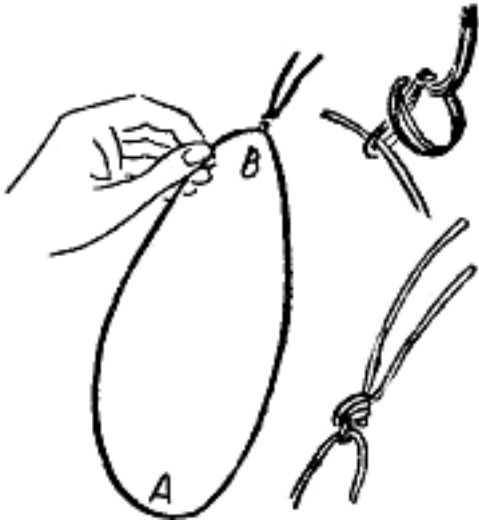


Now take a piece of same kind of cord about 5 or 6 inches long. Pinch large loop of cord at point B so that you can easily find point opposite from waxed ends. At point B loop this small piece of cord through large loop. When loop and small cord are held together with thumb and fingers, the effect is that of a piece of cord with cut ends sticking up from between fingers. This arranged loop with small cord may be placed behind some object in readiness for the trick. Get it and hold in left hand as shown in illustration.

SECRET AND PATTERN:

"Is there anyone here who understands the ecclesiastics of geometry? No one? Are you sure? If so, then I shall ex-

plain it with confidence. To begin with we have to have a circle. Has anyone a circle in his pocket? No? Such being the case, I will make a circle by tying the two ends of this cord together.



Tie ends of cord together. Illustration shows easiest way to do this. This method will prove very useful later on in the course also.

After ends are tied, show loop to audience. To them it looks as though you had made a loop from an ordinary piece of cord.

"Here's our circle."

Hold up cord with fingers and try to make it circular in shape.

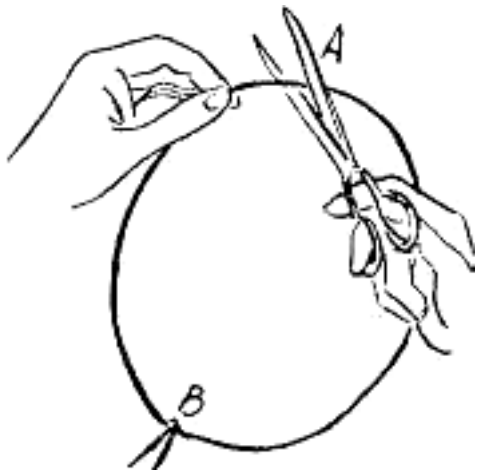
"Not such a good circle, but that is because of the hole we built it around. Of course, you understand that a circle is merely a straight line built around a round hole, and then the ears are chopped off."

Point to ends of cord to show ears.

"Anyway that's my story and I'm going to stick to it."

Pick up scissors.

"I cut a hole in the circle."



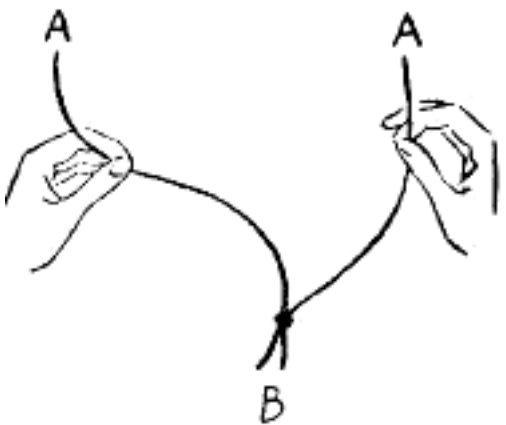
Hold up cord and cut through the place WHERE ENDS WERE WAXED TOGETHER. One end, of course, falls downward.

"And behold, the circle has gone."

Bring both ends together, but hold one about half an inch higher than the other.

"Just look, how uneven I cut those ends!"

Trim off upper end a little, then lower end a little, and then cut both ends even.



To the audience this looks like by-play, but to you it means destroying evidence. You are cutting the waxed telltale ends away.

Hold ends about a foot apart.

(6-8)

"There, they look a lot evener now."

Pull cord out straight.

"We have a straight line again—that is, it would be straight if it wasn't for those ears."

Nod your head to knot in center of cord.

"Now, we'll tie the ends together again."

Tie ends together.

"And there we have a circle again."



Show loop with knot on each side.

"That is, it would be a circle if it were! round and if it weren't for the ears. We now have two pairs of them."

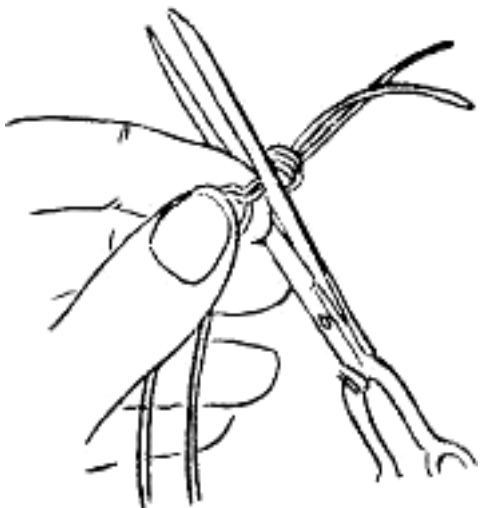


Hold the loop as shown in illustration. It gives a rabbit-like effect.

"Ah—there's a rabbit—body, head, and ears. I shall now show you the vanishing rabbit."

Let cord fall back into original large loop again.

"I think I'll cut the ears off."



Pick up scissors. Hold End B of cord, as shown, in left hand. This is the end with the short piece of cord tied around it. Cut the knot off. This does away with the short piece of cord. You may, if you desire, cut the ends two or three times before cutting the knot off. Start with the ends and work toward the knot.



Hold cord together in left fingers so that it looks as though you are holding two ends. The audience thinks that cord is cut and that two ends are covered by your finger tips.

"That's a good idea, only when you cut the ears off you still have two ends left, and we are just where we were before"

with our straight line. If I tie the ends together, we have ears again. But ah-ha-I have an idea."

Point at knot hanging downward.

"The knot is made up of two ends--this makes the other two ends in the middle. Well--well, why didn't I think of that before? That changes everything all around. With the two ends in the middle, I have but to say, 'Papa loves mama, mama loves papa,' and unite them as one."

Open up loop and show that cord is united.

"And they lived happy or unhappy ever after."

Hold up loop to look like a circle.

"Which, of course, brings us back to the problem of the circle. But why worry about a circle? We unknot the knot here. This gives us two ends, so we pull the string out into a straight line, and there I have proved that a straight line is the nearest distance between two ends."

Hold cord out by its ends so that it is pulled taut. Show palms empty while holding cord. Then give cord to a spectator.

"There sir (or madam, or miss), take this cord home and work on your lesson for tomorrow."

AN IMPROMPTU CUT AND RESTORED CORD EFFECT

This method of doing the cut and restored cord effect is commoner than the two methods which I have already given you. The reason for this is that this method requires no preparation. It can be done anywhere at a moment's notice. You can use this method on occasions when you cannot prepare your cord and have to work with what you have at hand.

EFFECT:

Spectator cuts a piece of string or cord, held by Magician, through the center with a knife or pair of scissors. Magician then ties ends into a knot. In a moment string is shown to be completely restored.

PARAPHERNALIA:

- 1--A piece of string or wrapping cord about 30 inches long.
- 2--Sharp knife or pair of scissors.

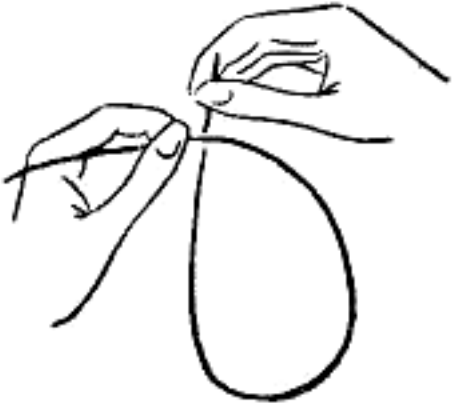


Show cord and hands freely.

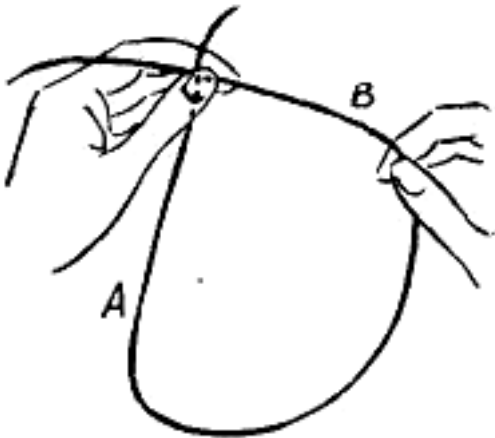


Hold cord in both hands as shown in illustration.

"I see by the papers that some inventor has brought forth a non-destructible wrapping cord. So much goods has been damaged because the string around packages breaks when express men throw the packages at each other. Something had to be done to prevent such losses. Let me show you how this newly-invented string works."



Bring end of string held in right hand around into position shown in illustration.



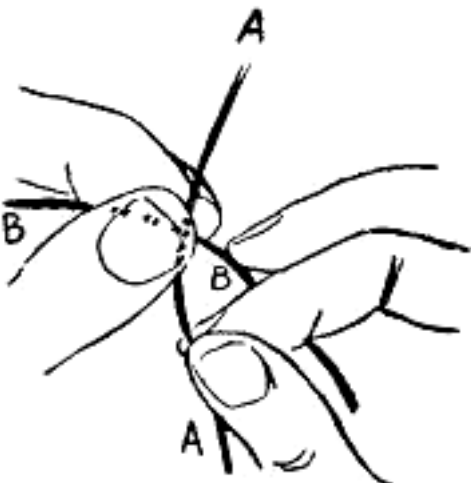
Grasp it between tip of first finger and thumb of left hand. Turn hand around so that palm faces audience. Spread fingers so that audience can see how string is held.

"Cord usually breaks in the middle--very seldom at the ends, so we must find the middle, which must be about in the center."

Look at part B of cord, extending between hands. As you see above, let go of end A of cord and let it drop. Audience can plainly see now that B is the middle of the cord.

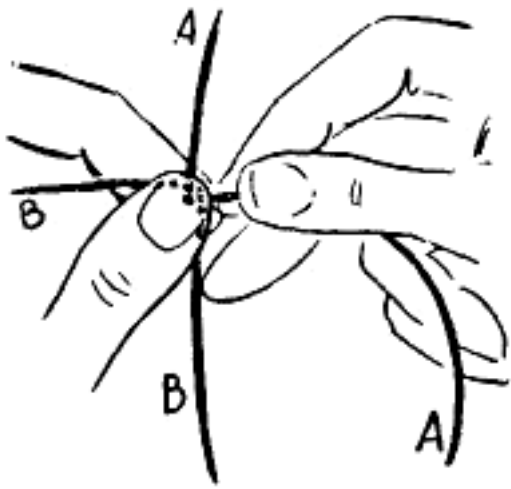
REPEAT PROCESS OF BRINGING END "A" UP in between finger and thumb of right hand. This repetition helps to convince spectators that the middle of the cord is really between your hands.

"There, that is good enough without measuring. Now, sir. if you will please take your pocket knife and cut the string through the middle"

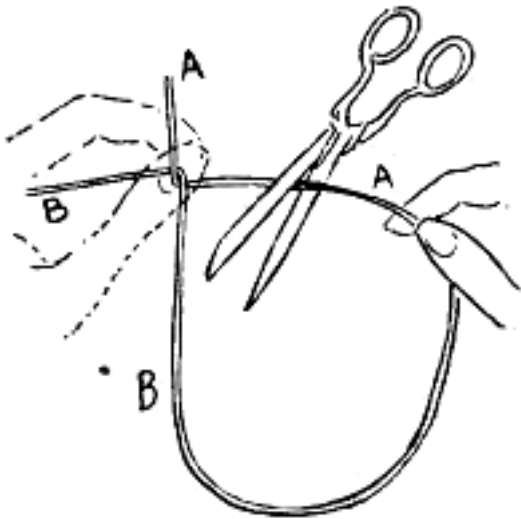


Or if you have a pair of scissors handy, ask spectator to use those. As you make the request, you make a movement that is very IMPORTANT in working the trick. Hold cord about six inches from you. Study illustration carefully.

Tip of first finger and thumb of right hand hold A. Second finger of right hand is used to push B downwards in front (towards audience), and A is brought upwards. In other words, just reverse the position of A and B. Note that while doing this, the fingers of both hands are close together.

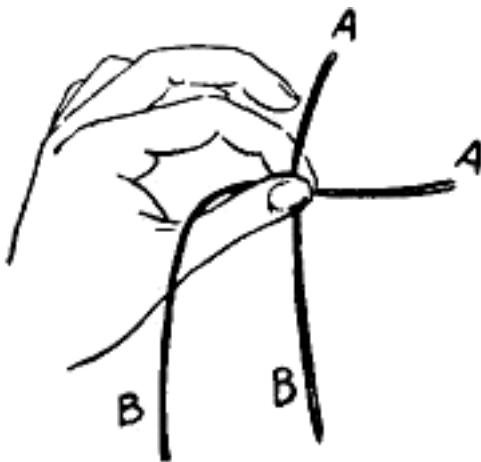


This movement leaves a twist in the cord between first finger and thumb of left hand. As soon as A and B are exchanged, move right hand along cord A to a distance about four inches away from left hand. Bring hands forward while doing this. To the audience it looks as though you had right hand near left and then as you brought cord forward, you merely slid right hand away from left.

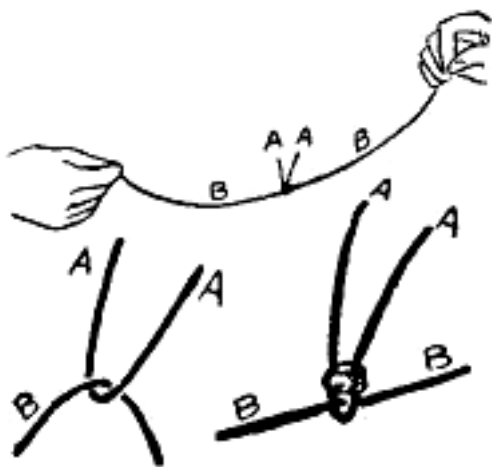


Movement of bringing hands forward appears to the audience to be a gesture in asking spectators to cut cord.

"Now just cut the cord here at the middle, that's near enough."



Spectator cuts cord. Allow cord held by right hand to drop. To audience it appears that cord has been cut in middle as two short ends extend upwards from fingers of left hand and the other two ends hang down.

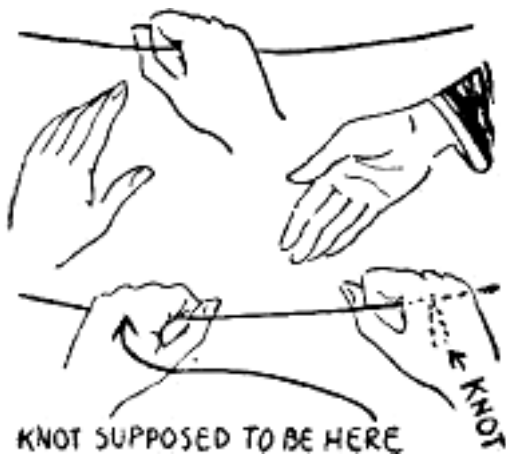


The audience thinks that you have had cord cut in half, but in reality cord has been cut only four or five inches from the end. The ends extending above your left fingers are the ends of the short piece of cord which spectator has cut off for you. Tie a double knot with the ends AA.

"Please, sir, hold this end of the cord, and you, sir, please hold this end."

Give each end of cord to a spectator to hold. The knot is in the middle of the cord. Even to the closest observer it looks as though the cord had been actually cut and the ends tied together.

"I had the cord cut by the gentleman here to represent the cord around a package breaking. Now, expressmen do not always bother to tie up the cord again as I have done here— besides the cord may be too tight to allow tying."



Cover knot with right hand and close hand over it. Then place left hand over right hand. Slip knot along cord under right hand by moving hand towards the right. Left hand is closed around cord WHERE KNOT WAS. The effect is that you covered knot with right hand, then changed your mind and covered it with left hand. Address gentleman holding cord at right.

"Please, sir, take hold of the cord a little nearer the middle."

(6-12)

Your right hand keeps the cord from dropping as spectator lets go of it and then takes hold of it nearer the middle. This gives you an opportunity to slip knot off of cord under cover of your right hand. Let right hand fall to side for a moment after slipping knot off.

"Now, will both of you gentlemen please hold the cord tight, and I will take my handkerchief"

Reach into right coat pocket with right hand and drop knot therein. Bring hand out suddenly and then reach into trousers' pocket and out again, as though you were looking for a handkerchief but couldn't find one.

"Never mind, I thought I had a handkerchief that I could cover the knot with. But I suppose the audience wants to see what happens anyway, and it is so much harder to see things when they are covered. However, to get back to this wonderful new indestructible cord. The point is that this cord, if it breaks while on a package, will not stay broken but will automatically come together again. It will restore itself as good as new."

Lift left hand from cord. Of course, the knot is gone as you placed it in your pocket.

"Pull the cord, gentlemen, and see whether it is not as strong as ever. Quite an invention, I assure you."

NOTE:

Another way of getting rid of small piece of string is simply to take string in hand and cut off piece by piece as you did in the Germaine version, until it is entirely gone.

After you tell your audience about expressmen not bothering to tie up the cord and that besides the cord may be too tight to allow tying, you may continue the patter in this way:

"So, if we cannot have a knot we must not. I'll cut off a piece for you and a piece for me. A great big piece for you and a little tiny piece for me and an extra souvenir for the lady over there."

As you say the last sentence of the above, cut the knot from the cord.

"We have no knot, but we do have a couple of good ends left. After all, what's a couple of ends between friends when we have inventors. What I wanted to tell you about this new indestructible cord is that when the cord on a package breaks, it will not stay broken. Each end seeks out its mate, comes together with the other end and sticks stronger together than true lovers at first sight."

Lift hand from cord.

"Pull the cord hard, gentlemen, and see whether it isn't just as strong as ever if not stronger. This shows the wonderful power behind inventions."

In performing this impromptu method of cutting and restoring a cord, you may do the trick with rope, string, or ribbon.

You may take a clothes line, for instance, unroll three or four yards of it, and perform the trick. Using a clothes line makes a good stage effect. Your patter could be based on a wash day experience.

Later on in the course, I will show you how this principle is applied to some pretty stage effects.

A handwritten signature in cursive script that reads "Harlan Tarbell". The signature is fluid and elegant, with a large, sweeping initial 'H' and a long, horizontal flourish at the end.

TARBELL SYSTEM, INCORPORATED, Chicago.

LESSON 7

In this lesson I give you five effects in rope and tape tricks. In these effects you learn an important magic principle.

1--A boy's coat is threaded on two pieces of tape, a knot tied, then two rings are threaded on tapes and another knot tied. Still another coat is threaded on tapes and a knot tied. The ends of the tapes are given to two boys to hold. Yet in a few moments performer succeeds in removing coats and rings from tapes without cutting or hurting tapes in any way.

2--Two pieces of soft white clothes line are threaded through a number of rings and rings are tied securely at middle of ropes. Two ends of the ropes are threaded through the sleeve of a borrowed coat, and the other two ends through the other sleeve. The coat is placed over a chair and, though rope is held at each end by spectators, performer removes the rings and the coat from the ropes.

3--Performer hangs himself with ropes. He ties two pieces of cord around his neck, yet in a moment he jerks ropes from his neck and shows that loop is not big enough to slip over his head.

4--An apple is threaded onto two pieces of tape. Two ends of tape are held in one hand and the other two ends in the other hand with the apple suspended between them. At a desired moment the apple falls from the tape undamaged and the tapes still remain extended from hand to hand.

5--Walking through ropes. Two ropes are placed in back of a gentleman and ends held on each side by two spectators. Upon command the gentleman walks backwards and the ropes apparently pass through him and are found stretched in front.

LESSON 7

This lesson, which we are about to study, is long and detailed. It is not difficult but it requires careful study and attention to each minute description. You learn a wonderful tape and rope principle and five excellent effects based on this principle.

Because of the length of the lesson and the time required to study it thoroughly, I will dispense with any preliminary discussion and lead you right into your actual work.

In your next lesson I will complete for you the History of Magic by tracing Magic's Relation to other Sciences which I have not covered in previous lessons.

THE ROPE AND TAPE PRINCIPLE

The rope and tape principle, which I teach you in this lesson, is one of the oldest principles in the realm of Magic. We have evidence that this principle was in use over 350 years ago, and for how many centuries before that time this principle was employed by magicians we can only guess. It is probable that this principle was handed down from the ancient Hindu magicians for the Hindu fakirs today do similar effects with two small ropes and one, two, or three wooden balls.

The first modern version of this secret we find in a pocket effect known as "Grandmother's Necklace," in which three wooden beads are threaded on two strings, the strings knotted, and the beads finally removed from these strings held by two spectators, without doing anything to the string.

Then some genius thought of working this principle on a bigger scale. David Devant, the great English magician, says about the modern effect with the rope and tape principle, "No one knows the name of the genius who first thought of doing this trick on a bigger scale, but there can be no doubt that the magician, whoever he was, was certainly a genius."

The five effects which I give you, based on this one important principle, are:

Coats, Tapes, and Rings—in which you use two boys from the audience.

Coat, Ropes, and Rings—a simpler version of the first effect.

The Prisoner's Escape or Hanging Oneself with Ropes— which is in the repertoire of almost every street salesman, side-show man, and medicine show trooper from the South Sea Islands to Alaska.

The Magic Orange—which is a modification of the Hindu Ball and Rope effect.

Walking Through Tapes—another interesting use of the double tape principle.

COATS, TAPES, AND RINGS

EFFECT:

Two boys are asked to come up on the stage to assist with the experiment. Each boy is given a piece of tape about sixteen feet long to examine. One boy is asked to remove his coat. The performer passes the two pieces of tape through the sleeves and then ties the tapes in a single knot. Two examined rings are then slid down on the tape to the single knot and another knot is tied over the rings. The other boy is asked to take off his coat and performer passes the two pieces of tape through the sleeves of the second coat and ties another knot in the tapes. The ends of the tapes are given to the boys to hold. Then in a few moments performer removes the first coat, then the rings, and finally the second coat, leaving the tapes intact stretched between the two boys.

PARAPHERNALIA:

1--Two pieces of black tape, about 16 to 18 feet long and 3/4 inch wide. (You can buy rolls of tape or braid in any drygoods or department store.)

2--A small black pin.

3--Two rings. You may use wooden curtain rings, napkin rings, harness rings, or the nickeled rings sent you with your other paraphernalia—or you may borrow two finger rings from someone in the audience.

I have in an emergency used two tea cups and threaded the tapes through the handles.

4--A table, on which to lay coats.

5--Two coats, which you borrow from boys who assist you.

SECRET AND PATTERN:

To Prepare:

Have pin stuck in lower edge of right hand side of vest, head pointing downwards so that it may be removed easily, as in Figure 1.

Table is in center of stage and thereon lie the two pieces of tape rolled up. The two rings may be on table or in pocket or anywhere within easy reach.

To Perform:

"For my next experiment I need the assistance of two boys."



Figure 1

As you say this, pick up the rolls of tape from the table.

"Two of the best or two of the worst boys in the audience. There, you are just fine. And that boy over there makes the other."

Two boys come up. Have one stand at the left of you and the other at the right.

Shake hands with the boy on the left.

"And may I ask what your name is?"

Whatever he says, call him by his first name.

In this instance, suppose he says, "John."

"I'm mighty glad to meet you, John."

Turn to boy on right.

"And your name?"

In this instance, suppose he says, "Robert."

"Robert? That's fine. Have you two boys met?"

If they say, "No" you introduce them.

"John meet Robert. Robert meet John."

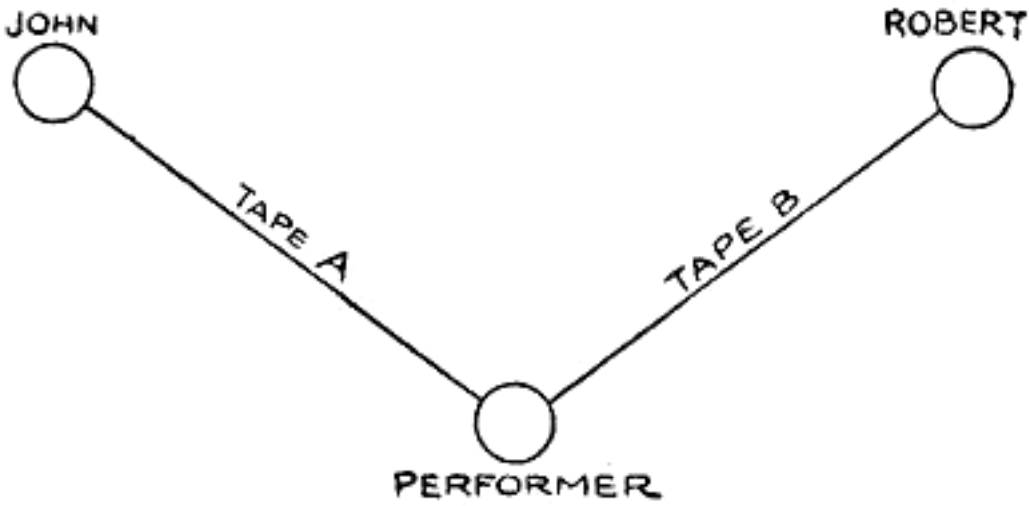
If they say, "Yes," omit the introduction. This opening is given for use when you are performing before strangers or on the stage. If at a friendly gathering, it is not necessary to use this beginning as you already know the names of the boys.

"By the way, are you the best or the worst boys? Both? Most boys are. First of all, I want you to examine two pieces of tape, each about four yards long. Look at them closely, pull on them to see that they do not break apart in some mysterious manner. John, you look at this piece and, Robert, you inspect this one."

Give an end of one tape to John and an end of the other tape to Robert.

"So that everyone will be

convinced that these are just two ordinary pieces of tape, each of you walk away toward the audience with your ends and I will hold the other two ends. We'll hold the tape up so that all can see."



This brings you and the two boys into a triangular position, holding the tapes (see Figure 2). Hold tapes high so that all can see them.

(7-3)

Figure 2

"This tape also acts as a measuring tape. You can readily see that it is just as far from John or Robert to me as it is from me to John or Robert. And John, as Royal Inspector, will you give your official O.K. to the tape? Now, both of you bring the ends of the tape to me. The exercise will do you good."

Take both ends of tape and place them evenly with the two ends in your hands. Hold all four ends in left hand while right hand picks up two rings.

"You might also like to inspect these two rings. If there is a trap door in one, you tell the audience immediately—or if fire should fly out, you give the alarm at once."



Figure 3

After rings have been given to boys, run your right hand along the tapes until you reach the middle of them. Hold tapes at that point in left hand, and while talking, take pin from vest with right hand (see Figure 3).

"Let Robert hold the ring and, John, if the ladies don't mind, let me have your coat. May I borrow it and do anything I want with it?"

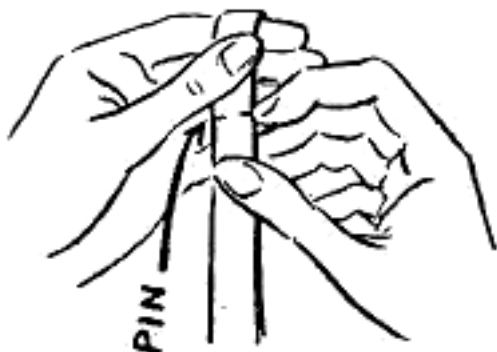


Figure 4

While you are talking and John is removing coat, slip pin into tapes, fastening the two pieces together, as in Figure 4.



Figure 5

Then place first finger of left hand on one side of pin BETWEEN THE TAPES and thumb of left hand on the other side of pin BETWEEN TAPES, as illustrated in Figures 5 and 6. You may help your left hand get into position with the right hand if necessary. Boy is taking off coat while you are doing this, and attention of audience is drawn to him.

"John, you are going to be a big help to me."



Figure 6



Figure 7

After boy has removed his coat, go towards him and reach for coat. In the meantime, your left hand drops to your side, you turn slightly to the left, and under cover of your left leg, throw Tape A forward by BRINGING LEFT THUMB UP OVER FIRST FINGER. Then remove other fingers from between tapes.

The two tapes are now doubled back, each upon itself. The joining of the tapes by the pin is covered by thumb and first finger of left hand, as in Figure 7.

THIS IS A VERY IMPORTANT MOVE. The success of the trick hinges on this move. I want you to practice this move until you can do it speedily, easily, and smoothly so that you will not be noticed. At no time

must your eyes be on the

(7-4)

tape while you are pinning it or while you are performing the above move.

"Hold your coat front towards me and back towards yourself, and I will put the tapes through the sleeves."

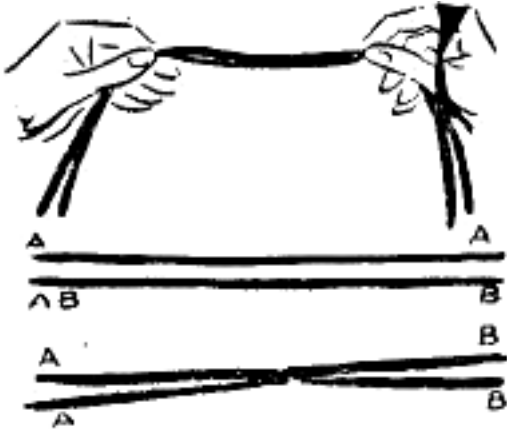


Figure 8
Figure 9
Figure 10

As you say this, place right hand up in front of left hand and spread tapes apart, as illustrated in Figure 8. To audience it looks just as though you held the two tapes by the middle. They suspect nothing unusual. In reality, this is what you have. You started with two tapes AA and BB, as shown in Figure 9. You pinned them together at the middle and performed a move which brought AA together and BB together, as in Figure 10. Thus instead of having one end of each tape together, you have two ends of one tape together.

"I will thread these two ends into and through the right sleeve. Reach up the sleeve, Robert, and pull down the two ends."



Figure 11

Thread the two ends of tape on right side into the right coat sleeve and pull all the way through. Figure 11 shows threading of tape into sleeve. Then cover left hand with right hand and take joining of tapes in right hand. Audience will not see joining as it is covered by right hand.

"And these two ends through the left sleeve. Reach up and get these two ends too, Robert."



Figure 12

Then thread other two ends of tapes through the left sleeve of coat. Figure 12 shows tape threaded into sleeves.

Progress so far with effect is shown in illustration.

Then take coat from boy with left hand, grasping coat by the collar. Turn back of coat to audience and then release hold on tapes. To the spectators it looks as though coat is threaded securely on two tapes.

"You are convinced, Robert, are you not, that John's coat is well threaded on the tapes? I will just lay the coat on the table so that I can tie the coat on."



Figure 13

Lay coat on table, open side down. Pick up the four ends of tapes and tie a single knot, bringing ends of sleeves close together, as illustrated in Figure 13.

"I had to muss the coat up a bit but I couldn't very well tie a knot without doing that. I know, however, that your tailor will not mind, and you certainly don't, do you, John? I always ask permission to do it afterwards as it is much safer. Now, Robert, give John a ring and you take one,"

and each of you thread a ring on two ends of the tape and have a race to the winning-post. Just slide them down. The knot is the winning-post."



Figure 14

Boys slip rings onto tape and push them down to knot. See Figure 14.

"Now I will tie another half knot, making a complete knot. And, Robert, by the way, may I borrow your coat? I guess you haven't anything breakable in your pockets, have you?"

Take coat from Robert and hold it for a moment.

"I was doing this trick the other night and a boy had a bottle of sticky medicine in his pocket. The cork came out of the bottle and so did most of the medicine—and a good time was had by all. The boy got well. He thought he'd take his medicine with the party instead of afterwards all alone. Only last night a gentleman was helping me and he had a bottle in his pocket that he said was medicine."

Thread coat onto tapes in the same way that you did the first coat—two ends of tape through left sleeve and two ends through right sleeve.

"There the second coat is on the tapes. John, you hold two ends."

Have John stand at your left and give him tapes coming out of coat sleeve nearest him.

"Robert, you hold the other two ends."

Have Robert stand at right and give him the other two tapes coming from the other sleeve. Boys should be several feet apart so that audience can readily see performer and coats. Turn to John.

"Please give me one of your ends. Either one will do."

Take one of the ends from John.

"And, Robert, give me either one of your pieces of tape."

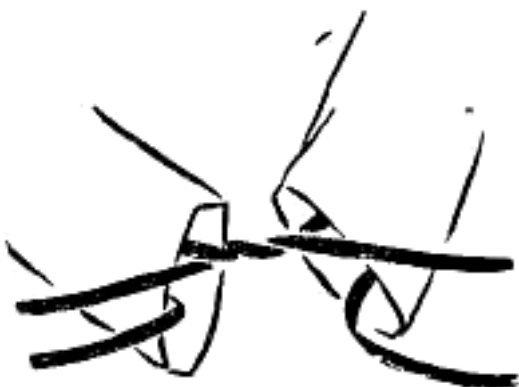


Figure 15

Take one of the ends from Robert. Tie a single knot with these two ends, as in Figure 15. Thus far you have the tapes threaded through one coat, a single knot tied, two rings threaded on the tapes, another single knot tied, a second coat threaded on, and a third single knot tied.

"I'm going to tie one more knot and this I will leave in full view of everyone. See, Robert, your coat is now all mussed up like John's. May I muss your coat, Robert? Thank you. Robert, hold an end of the tape again."

Give an end of tape to Robert.

"John, hold this end together with your other end."

Give other end to John.

The reason for tying the last single knot is to exchange ends of the tapes and give Robert the end that John held, and John the end that Robert held.

Now each boy is holding A and B ends of tapes instead of AA and BB as formerly.

"Now to test your powers of observation. Tell me confidentially which went on the tapes first, the coat or the rings."

As you say this, reach under John's coat, which is the one underneath, and take out the pin which holds the tapes together. Stick the pin into your left coat sleeve under cover of John's coat.

"Rings? Did I hear someone say rings? I generally find rings are mentioned by the ladies. Most of them are much interested in rings. Don't laugh, Robert, you'll find it is a very serious matter some day. Well, John's coat went on first, then the rings, then Robert's coat—so if John's coat went on first, we will take it off first. You are holding your two ends, aren't you? And you are holding your two ends, aren't you? Now then, one-two—Don't look so serious, John. It may come out all right. One-two-three—there's the coat."

Take coat off tapes. This, of course, is very easy to do. Coats should be raised off of table, holding bundle with left hand and John's coat with right hand. After you have removed bottom coat, give it to John, who can hold it over his arm.

"Just have a look at it, John, and see that I have not torn it to pieces and then sewed it together again. All right? Now for the rings. Robert, would you know your ring if you saw it again? You wouldn't. I had you look at it in the first place so you would know it again. Well, here it is. It must be yours because it has a hole in the middle and, John, the other one must be yours."

In removing rings you may let coat fall on table if you desire. Be careful that ends of tape under coat are never visible to audience. When rings are removed, give one to each boy to examine.



Figure 16

EXERCISE GREAT CARE AT THIS STAGE. There is danger of the boys suddenly pulling on ends of tape and bringing the trick to a premature conclusion. To prevent such a catastrophe, after rings have been removed and all knots have been untied, insert your first or second finger of left hand in one loop of tape and thumb of left hand in the other loop and hold them tight together, as illustrated in Figure 16. Ask boys to pull a little if there is unnecessary slack in tapes.

"We still have Robert's coat on the tapes. I should like to have both of you boys pull hard on the tapes when I say, Three. Don't pull until I say, Three. If you do, you may pull the whole back of the coat out. Robert wouldn't like to have the back of his coat so removed. Are you ready? You can all see the knot in the middle? Now, one-two—"

Hesitate a moment here. The boys will probably pull hard even though you haven't said "Three," because they expected you to say it.

"No, I didn't say three. Something happened anyway. Just a few stitches in the arm. But what's a few stitches between friends, eh, Robert? There's the knot still there and you are still holding the ends of the tape. One-two—THREE!"

Illustration 17 shows effect at this stage. You are holding coat with right hand. (Your left hand is holding loops of both tapes behind coat.) There is a knot in the tapes between the sleeves. A boy at each end of tapes is holding AB and AB.



Figure 17

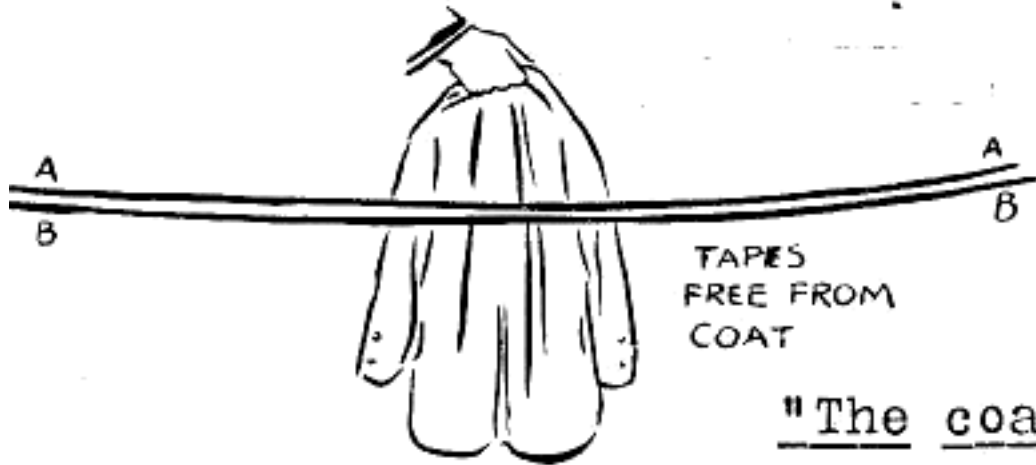


Figure 18

At your count of Three, boys pull and you release tapes. This move frees the coat and leaves it hanging from your right hand. The two tapes are left stretched straight between the two boys. See illustration 18.

"The coat is off and the knot has vanished and you, boys, are still here. Robert, here is your coat. Oh, the torn seam. Hocus Pocus—there, everything is all right."

Take tapes from boys and shake hands with them, if you are on a stage and boys are going back to audience. In a parlor this is not necessary.

"Good-bye, Robert. Good-bye, John. When you get married and you help your wife do the washing, you will not have to use clothes pins. You can thread the clothes on the line. Then hocus pocus, and they are off again."

When you have left stage, don't forget to replace pin in edge of vest.

NOTE: If you use men for assistants, merely vary the patter a bit to suit the occasion.

* * * * *

COAT, ROPES AND RINGS

This is a modification of the effect just described. It is worked on the same principle but is done with a number of rings, two ropes and one coat. I give you these two ways of working so that you have two methods at your command and may use the one best adapted to conditions under which you are working.

EFFECT:

Performer asks two gentlemen to come forward and assist him. He gives them six rings to examine and thread onto two pieces of rope, about four yards long each. Performer ties rings onto center of ropes with single knot. One man is asked to remove his coat. Two ends of the rope are threaded through one sleeve, and the other two ends through the other sleeve. Coat and rings are then placed over the back of a chair. Another single knot is tied with one of the ropes outside of the coat, and each gentleman is asked to hold two ends of the ropes. In a moment magician removes all six rings and the coat, leaving the ropes stretched straight between the two men.

PARAPHERNALIA:

- 1--Two pieces of soft white clothes line, each about four yards long.
- 2--A small piece of white thread.
- 3--Six wooden curtain rings or harness rings. These rings should be large.
- 4--A chair with a straight back. A dining room chair will do.
- 5--A borrowed coat.

SECRET AND PATTTER:

To Prepare:

Place the two pieces of rope with each two ends together. Find middle of the two ropes and wrap a piece of thread (No. 50 or 60) around both ropes twice. Tie thread securely. See A in illustration 19.

Now fold ropes, each back on itself, as you did the tapes in the first effect. See B and C in illustration 19.

Coil up ropes in a way that will enable you to get at the joining and one set of ends easily. Have ropes thus prepared and rings on your table ready for your performance.

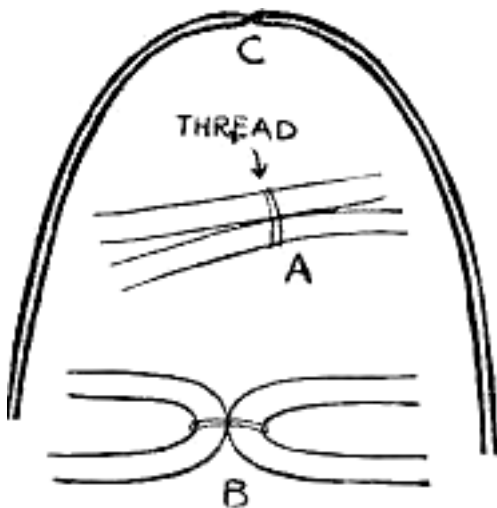


Figure 19

To Perform:

Pick up the six rings and come forward.

"Before beginning a peculiar Hindu experiment in magic, I would like to have two gentlemen help me."

Get two gentlemen to come up from audience. If they are strangers to you, shake hands with them to make them feel comfortable. Have one stand at the right of you and the other at the left, and both a little in front of you. For convenience we will call the man at the left L and the man at the right R.

"I have six rings—six solid rings. Would you kindly examine them?"

Give rings to R.

Then go over to table and pick up ropes. Cover joining of two ropes by holding ropes at that point in closed left hand. With right hand spread four ends of ropes apart so that audience can see that you just hold two ropes by the middle.

"Now that you are satisfied about the quality of the rings, will you, sir, please thread the six of them on this end of the rope?"

Give R two ends at right, picking them up with right hand.

"Both of you please hold both ends of rope securely and do not let them drop."

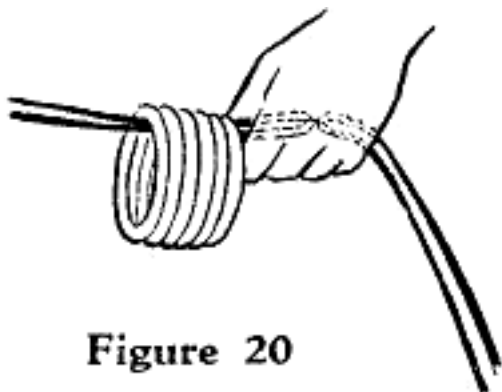


Figure 20

Slide rings up against left hand, as in Figure 20. Then under cover of both hands, slide rings together over joining of ropes until joining is in the center of the rings and is completely covered.

"Now bring up your ends so that I can tie a knot over the rings."



Figure 21

Tie a single knot over rings. Let ends fall to the floor. Illustration 21 shows knot tied.

"There, the rings are tied securely. (To gentleman on left.) And would you be so kind as to let me have your coat? I would use my own but the audience might think I have some kind of special preparation that allows my coat to fall apart and come together again."

(7-10)

Gentleman removes coat. If he takes things out of his pocket and transfers them to his trousers, say:

"The gentleman evidently knows me. But, sir, you may leave the articles in your coat if you choose, unless you have something breakable, such as bottles—medicine bottles. bric-a-brac, etc. Hold your coat with front toward me so that I can thread the ropes through the sleeves. (To R.) Reach up into the sleeve and pull the rope through."

You put two ends of rope inside of coat and through right sleeve and R pulls the ends out of sleeve.

"Hold the ends, sir, and tightly. These other two ends I will thread through the left sleeve and I will ask you, sir, (to L) to reach up into the sleeve and pull the ends out."

Place other two ends into inner part of left sleeve and L pulls them out of sleeve.

"Hold these two ends tightly also. We will now place coat and rings over this chair. But before doing so, I want the audience to see that the rings have been tied onto the ropes and the ropes really threaded through the coat sleeves."

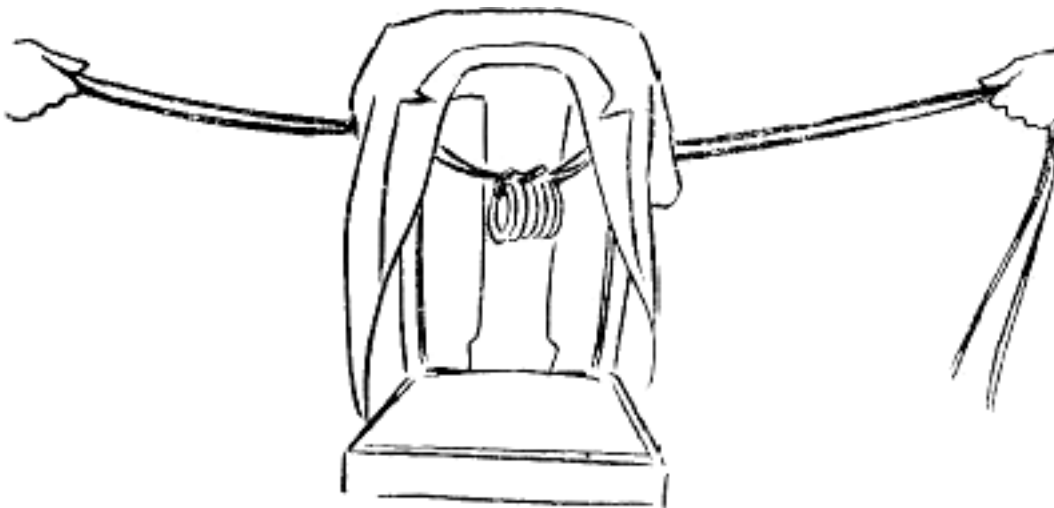


Figure 22

Move back towards chair. Show inside of coat with rings hanging on ropes to audience. Figure 22 illustrates coat on chair.



Figure 23

Chair should be placed with back to audience.

Place coat over back of chair with back of coat towards audience. See Figure 23.

"Gentlemen, each of you give me an end of one of the ropes which you are holding. Either one--you may have your choice."

Gentlemen each give you end of rope.

"I will now tie still another knot on the outside of the coat so that you can see it. It makes the coat doubly secure."

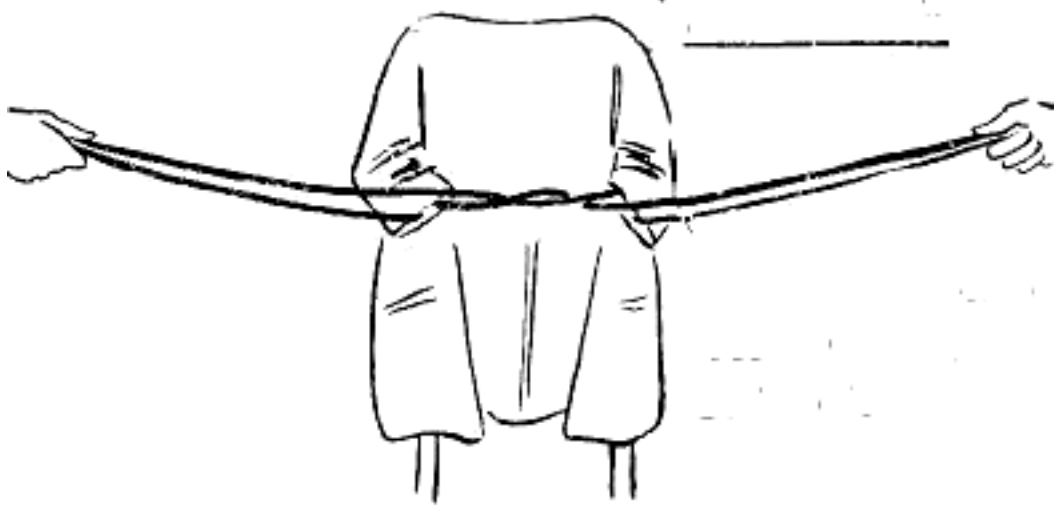


Figure 24

Tie a single knot with two ends of ropes. This brings the end given by L over to the right and the end given by R to the left. See Figure 24.

(7-11)

"And will you please hold the ends again?"

To the audience the knot looks like extra security but to you it is just a necessary ruse to get an end of rope held by L over to R and vice versa.

"Hold tight, but let me have just a little slack in the ropes. Do not draw them tight until I tell you to. You are thoroughly convinced, gentlemen, that the rings and coat are well secured on the ropes and that you are holding the ends? Very well."

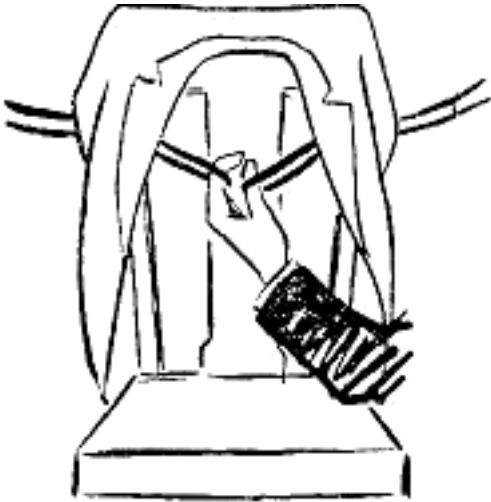


Figure 25

Reach up under coat, which screens movements of your hands. Break thread by pulling loops of ropes apart. BE CAREFUL NOT TO LET RINGS DROP. Untie the knot and insert first finger and thumb of left hand through loops of rope to prevent premature pulling of ropes from coat. Figure 25 illustrates position of fingers.

"By the way, are either of you gentlemen married? Well, do you have any trouble in getting out nights, especially when the wife locks the doors and windows? Let me give you a secret. I will show you how to go right through the door or even the roof. Just like this. Here we had six rings tied up for the evening, but look! One-two-three-four-five-six--all ready to go out for a good time."

As you say this, hold up rings one at a time, passing them from left to right hand. You will find it easy to hold rings on three lower fingers of left hand before passing them to right hand.

"Will you examine them, sir, and see if the rings are all right? Didn't hurt them a bit."

Give rings to R with right hand. Meanwhile for safety, keep your hold on loops of ropes with left hand.

"That leaves us with the coat knotted on the ropes. See the knot. When I say Three, pull the ropes tight. Pull hard. One-two-THREE."

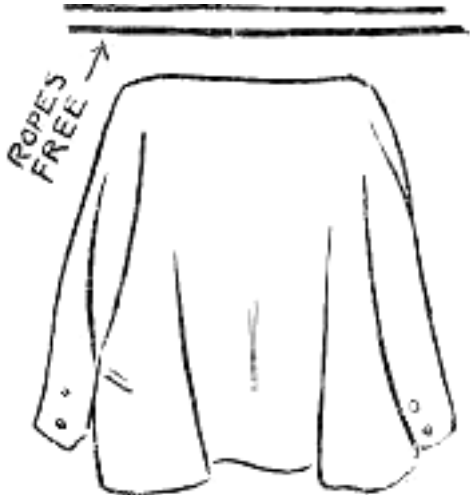


Figure 26

At Three, release your hold on ropes. Assistants pull ropes out of coat and the ropes are stretched straight between them. The coat remains on the chair, as in Figure 26.

"See what a little help will do in getting a friend out of trouble. Here, sir, is your coat as good as ever."

Give coat to L and take ropes.

"Now that you understand the process fully, I hope that neither of you will hesitate to go out evenings even if you are locked or tied in."

OR

HANGING ONESELF WITH ROPES

EFFECT:

Performer shows two pieces of rope, each about six feet long. He then places the ropes around his neck and ties them securely. In a moment he jerks the rope off, apparently right through his neck; for when he shows the ropes, the loops, which a moment before were around his neck, are still in the ropes.

PARAPHERNALIA:

Two pieces of rope, preferably soft white clothes line -- each about 6 ft. long.

SECRET AND PATTERN:

To Perform:

Bring forth the two ropes.

"Some time ago a magician was in a strange land and amongst strange people. His wanderings about the world had led him into peculiar places. Whether the people of this particular land were cannibals, Hottentots, or wild men I do not know, but when these natives saw the magician they quickly pounced on him and made him prisoner. He was led before the king, who, after some peculiar jibberish, beckoned to the Royal Executioner. The Royal Executioner thereupon took two ropes, something like these which I have here in my hands."

Show ropes and give them a good pull to show that they are strong.

Then hold ropes in right hand with middle of ropes across palm of hand and ends hanging down. Now pass one of the ropes over onto left hand.

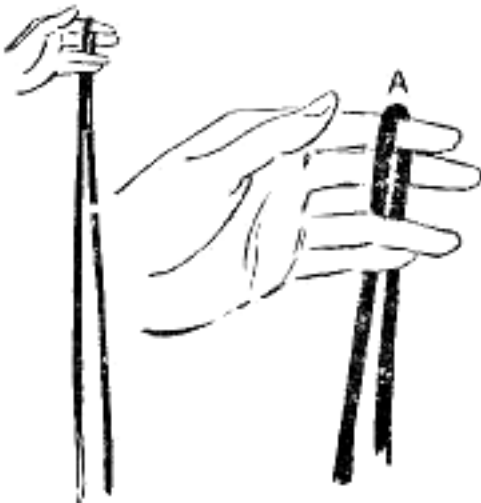


Figure 27

Rope now on left hand is held in a special manner. Study illustrations carefully. With back of hand toward audience, lay the middle of the rope over forefinger of left hand. Pass second finger in front of rope and third and fourth fingers behind it, as in Figure 27.

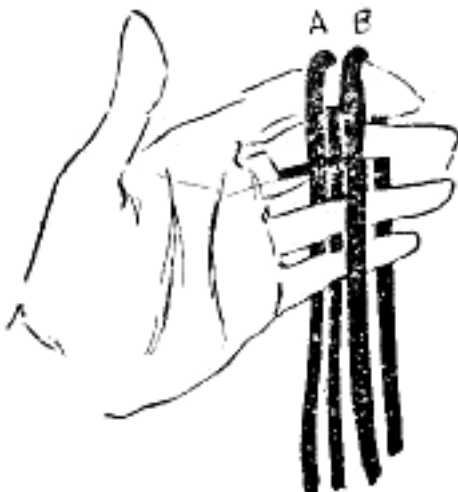


Figure 28

Now lay the second rope B over left forefinger so that all of your fingers are between the strands of the rope. Positions of both ropes shown in Figure 28.

PRACTICE LAYING THE ROPES ON LEFT HAND UNTIL YOU CAN GET THE ROPES INTO POSITION ALMOST AUTOMATICALLY.

"Yes, the ropes were something like these except that they were made of buckskin or certain strong grasses or fibers from the bark of trees."



Figure 29

Now note carefully the position of the two ropes on left hand. Study illustration 29, noting exact position of each of the fingers.



Figure 30

Insert third and fourth fingers of right hand between A2 and B2 and lift up A1 and A2 a little. Keep first two fingers of right hand in front of left hand to screen movements. See Figure 30.



Figure 31

Hold third and fourth fingers of right hand right against edge of palm so that your grip on Rope A is secure. The left thumb and little finger should also have a tight grip on Rope B. See Figure 31.

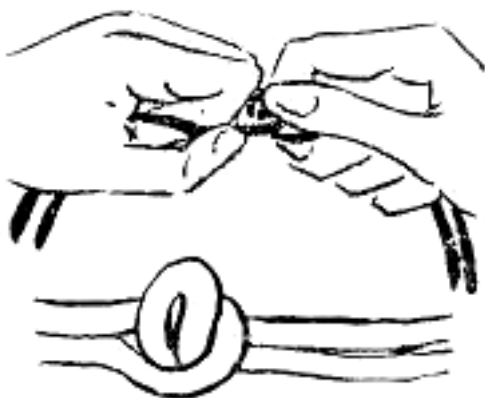


Figure 32

Slip left second finger out of loop in Rope A and hold finger against front of Rope B. Press right thumb down on loop in Rope A, pulling loop A up and over loop in Rope B, and hold it tight between thumb and first finger of right hand, as in Figure 32. Hold other fingers of right hand close together in front of left hand to screen movements.



Figure 33

Slide left hand along Rope B to about a foot from joining of ropes.

This series of movements must be practiced until they can be done as one continuous movement. The forming of this fake joining of the ropes should take but a moment. Figure 33 shows ropes joined. If your movements are fast and screened with your fingers, the audience will not suspect that you are manipulating the ropes in any way. A slight swinging of the arms also helps to cover movements.

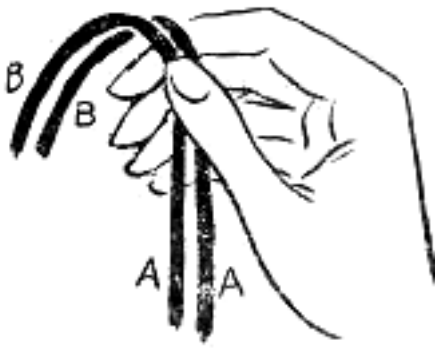


Figure 34

When the rope is finally held in the right hand with fake joining between first finger and thumb, back of hand to audience, spectators think you are merely holding the two ropes by the middle. Effect illustrated in Figure 34.

THE MAKING OF THIS FAKE JOINT IS, OF COURSE, THE FUNDAMENTAL MOVE IN THIS TRICK. On your skill in making this joining quickly and without detection depends your success in presenting this effect. Practice these moves before the mirror until you have mastered them.

"Then the Royal Executioner placed the ropes around the magician's neck."



Figure 35

Put right hand back of your neck and force joining of two ropes in between neck and collar, as in I, Figure 35. As you do this, open up loop a little (see illustration 2, Figure 35) so that loop A is not folded over B. This is done so that ropes will come apart easily when you desire to pull them off your neck. Sometimes I leave one loop bent over the other and held tight between my neck and collar so that I can jerk on the ends of the ropes to show that they are secure. Then I reach back of my neck and loosen loops. Pressure between neck and collar holds ropes in place.



Figure 36

You now have ropes arranged around your neck--the two ends of one over your right shoulder, and the two ends of the other over your left shoulder, with the joining at the back of your neck, as illustrated in Figure 36. The spectators, of course, think that both ropes are around your neck.

"And he tied the ropes together in several knots."



Figure 37

Tie the four ends of the ropes together in two or three knots, not too close to neck. See Figure 37.

"Now the magician was a magician. Tying ropes around his neck seemed serious to him, as he thought they might hang him. He grasped the ropes with his hands and tried to get them off over his head, but he found that they were tied too tight for that."

Show ropes well tied around your neck. Then place right thumb between ropes A and A and between B and B. Grasp two upper ropes A and B by closing first two fingers around them.



Figure 38

Insert first two fingers of left hand between the same ropes but under right hand. Grasp two lower ropes A and B firmly with these two fingers, as in Figure 38.

The knots in the ropes should be far enough away from your neck to do this comfortably.

"Then he knew he would have to call on his magic power to aid him. He let out a yell that startled the king and then he uttered slowly some startling syllables which neither he nor the king knew. And then he gave the ropes a jerk."

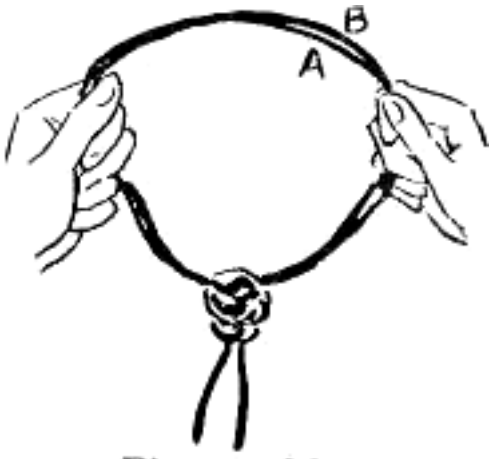


Figure 39

Jerk ropes and, as you do so, spread the two ropes apart into loops, as illustrated in Figure 39. The illusion is that the ropes came right through the neck in the form of these loops. The audience thought you put the ropes around your neck and tied them together, thus forming these loops. Now when the ropes come off your neck in the form of these loops, the audience is convinced that you did put the ropes around in this manner and they are puzzled beyond words.

(7-15)

"And the magician was free—the ropes as solid as before. The king fell dead, the magician became king and lived happily ever after."

NOTE: This effect may be presented without patter if desired, especially if it is presented with other rope effects.

* * * * *

THE MAGIC ORANGE

This is a very interesting little experiment, similar to that performed by John Mulholland and Milton Smith, worked on the same principle as the three preceding effects. When smoothly performed and clothed with a little story, it makes an excellent trick for parlor, club, or stage.

EFFECT:

An orange with a hole punched through the middle is threaded onto two pieces of tape, each about four feet long. Tapes are tied in a single knot around the orange, and two spectators are requested to hold the ends of the tapes. At a command from the performer the orange falls from the tapes into his hands. The tapes remain stretched between the two spectators holding it and the orange is in the same condition as it was at the beginning of the effect.

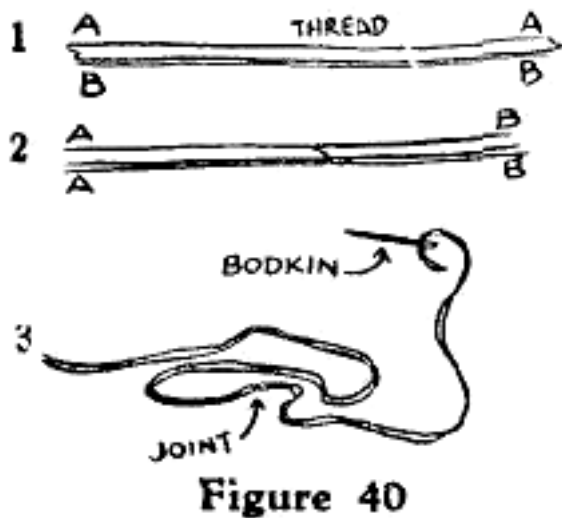
PARAPHERNALIA:

1--Two pieces of tape, each about four feet long and 1/4 or 3/8 of an inch wide.

2--A bodkin or large needle into which you can thread tape and push it through orange.

3--An orange or apple. You may use either.

SECRET AND PATTERN:



To Perform:

Spread out one piece of tape and on top of it lay the other piece, end to end, as in illustration 1, Figure 40. Tie a piece of thread around the middle of both tapes. Double back the top piece and double under the bottom piece. You now have the two ends of one tape AA together and the two ends of the other tape BB together, as illustrated in 2, Figure 40.

Thread BB on a bodkin that is at least four inches long. Fold tapes so that they lie in a heap on table. Be careful to have joining of tapes away from audience. See 3, Figure 40.

Have orange fixed with hole through middle, about a quarter of an inch in diameter. This hole can be made with a pointed lead pencil or a spike.

To perform:

Come forward with orange.

"I suppose most of you are familiar with fairy stories. Have you heard the story or legend about the Magic Orange? In a far away country lived a great Prince and every year he held a great fair to which farmers brought their choicest fruits for exhibit. The finest fruit was selected from this exhibit for the beautiful Princess. At this particular exhibit, a great prize was to be given for the choicest orange in all the land."

Show the orange and give it to a spectator to examine.

"I shall use this orange for the experiment. I have made a hole through it with a pencil. Examine it if you will, sir. The reason for the hole is that it was customary to thread ribbons through the choicest of fruit so that it could be hung up and it would not be necessary for anyone to touch the fruit in examining it."

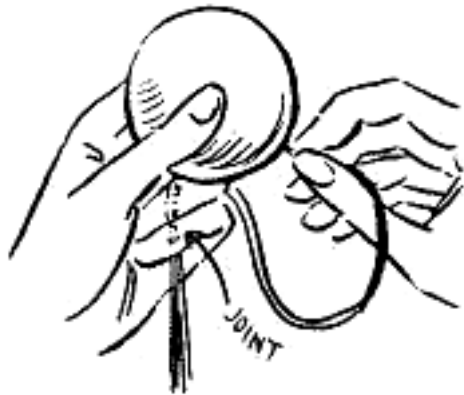


Figure 41

Take back the orange. Now thread it onto the tapes by pushing the bodkin through the hole in the orange, as in Figure 41. If you have no bodkin, push ends of tape through with a lead pencil.

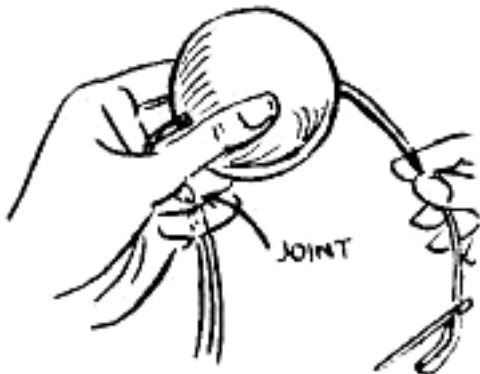


Figure 42

When you pick up tapes from table, be sure that joining is well covered with left hand. See Figure 42 for correct position.

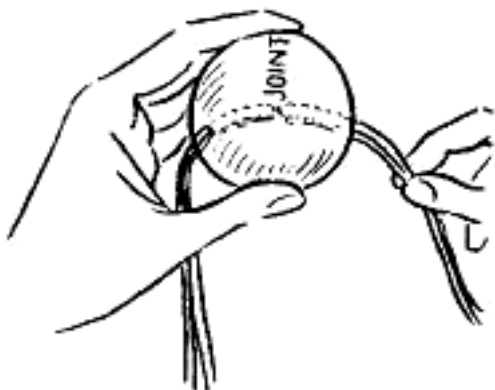


Figure 43

Draw the tapes through the orange with right hand until the joining is in center of orange, as illustrated in Figure 43.

I have two ways of doing the threading of the orange. One way is to pick up tape with joining covered by left hand and come down towards audience while threading orange. The other way is to bring the orange to the table in left hand, pick up bodkin with right hand and thread orange, letting the joining of the tapes remain on the table. Then I pick up the tapes at the joining with left hand and pull tapes through with right hand until joining is in center of orange. If orange is held in front of tapes, they can be drawn into orange without joining being seen even if it is not covered by left hand.

Practice ANGLES OF VISIBILITY on this before your mirror.

Remove bodkin from tapes.

"So I will thread the orange on these tapes and have it held up so that all can see it. To make it doubly secure, I will tie a knot around the orange."

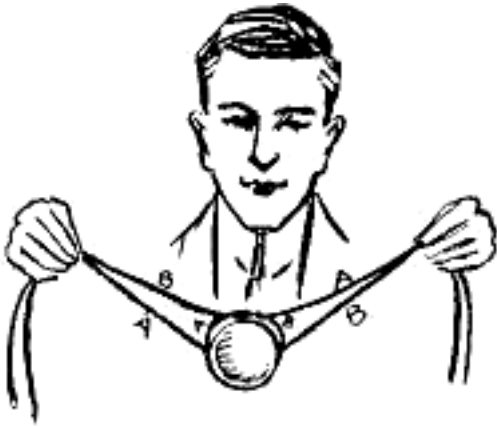


Figure 44

Take one end of Tape A and one end of Tape B and tie a single knot with these two ends, reversing their direction. Thus your left hand now holds AB instead of AA and your right hand holds AB instead of BB, as illustrated in Figure 44. (I explained the reason for doing this in the first effect, Coats, Tapes and Rings.)

Now hold orange up high.

"And so it came to pass that this fine orange won first prize. When the man came forward to claim it, the peasants were indignant, for they said, 'This man has no orchard. He is a thief. He has stolen our fruit and exhibited it.' Then many peasants claimed it as their own. Now, fortunately, the Prince was a Magician so he put a magic charm on the orange."

Now you request the assistance of two men from the audience.

"I would like to have two gentlemen to assist me so that I can find the owner of the fruit with the magic charm. Thank you, just come forward, and you also, sir. (To one). Just hold these two ends. (To other). And you, Sir, hold these two ends. Hold ends tight and do not drop them."

The men are each given two ends to hold. The audience can see the orange suspended from the tapes between the men. You stand behind the orange.

"According to the legend, the Prince said that the orange could not be removed from the ribbons by anyone but the rightful owner—that if the real owner of the orange would touch it, it would fall into his hand. One by one the peasants came forward and touched the orange, but it remained securely on the ribbons. Then came forward a young man from whose orchard the orange has really been stolen. He held his hand under the orange thus."

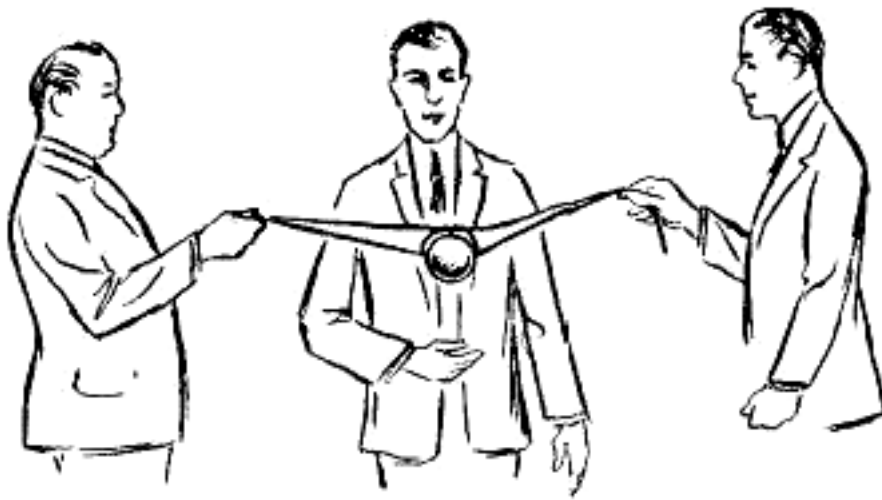


Figure 45

Hold right hand about a foot beneath the orange. Figure 45.

"Now, gentlemen, pull hard on the tapes."

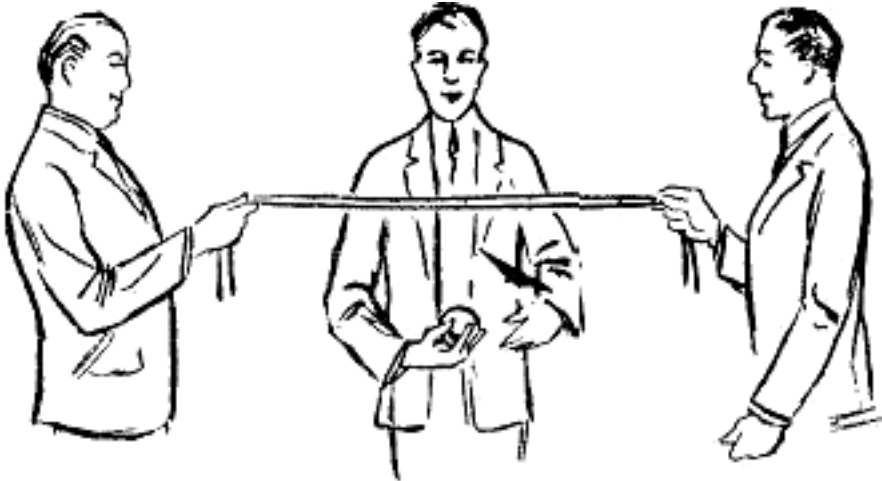


Figure 46

When assistants pull hard, the thread holding the two tapes together breaks. The orange falls into your right hand, which is beneath it ready to catch it. The tapes are stretched out straight between the two assistants, as in Figure 46.

(7-18)

"And just as the Prince Magician said, when the rightful owner came the orange magically dropped from the ribbons into his hand."

Take tapes from the gentlemen and thank them. They go back to their seats.

"The moral of which is—Some people claim to be movie actors, but the nearest they get to Hollywood is eating oranges that come from there."

WALKING THROUGH TAPES

This is an effective version of the double rope principle and coupled with showmanship it is very puzzling.

EFFECT:

Two long tapes are freely shown and passed up under a gentleman's coat and behind him. One of the tapes is tied in a single knot in front of him to secure him still further. The ends of ropes are given to two spectators to hold, one standing at left, and other at right of gentleman who is bound. The latter is told to walk backwards with the result that the tapes instead of being behind him are now stretched in front. He has apparently walked through the two tapes.

PARAPHERNALIA:

Two long pieces of tape, each about ten feet long.

TO PREPARE:

Have tapes fixed with thread through center similar to tapes in the magic orange effect. Fold tapes back on themselves so as to form the fake joint. Place tapes on table or suit case (if you use one for performing) with fake joints concealed from audience.

SECRET AND PATTERN:

To Perform:

Pick up tapes and in doing so cover the fake joint with the left hand. Allow ends of rope to fall to floor. It is easy to convince audience that you hold but two harmless pieces of tape.

Invite three gentlemen to come up and assist you.

Address the one who looks the best natured and say,

"Pardon my asking sir, but are you much of a walker? Do you take an interest in walking or would you rather ride? Most of us would. I ask this because I am going to perform an odd walking experiment. Perhaps one of the oddest you have ever encountered. I got the idea from Teddy Roosevelt. I will ask you to face the audience while I pass these two tapes behind you."

The other two assistants should be standing one at the right and another at the left. The left side of stage is to your left when you face audience.

Stand at right side of gentleman who is to be the walker and pass left hand up under his coat and behind his back, then reach around him with right hand and take tapes.

Address gentleman to left side of walker.

"Will you be kind enough to take these two ends of the tapes and hold them tightly?"

Give him the two ends in your right hand.

Address gentleman at right.

"And I will have you take these other two ends."

Release fake joint held with left hand and run hand along tapes so you can easily present the two other ends to spectator helping you.



Figure 47

Study diagram 47 and you will readily see position of ropes as held by assistants.

The two gentlemen on each side should be far enough away so as to take in the slack in tapes and yet not pulling hard enough to break the thread in joint. Audience should be readily able to see that man in middle stands in front of the ropes.

"Now gentlemen each of you holding the tapes, give me an end of any one that you are holding and for safety we will wrap our friend, the walker, up in the rope and tie it securely around him."

Take an end from each gentleman, tie a single knot in front of the walker and give back the opposite ends to the assistants from what they originally held. We discussed the principle thoroughly in the "boys, coats and rings."

"Gentlemen, please hold the ropes securely. Note carefully how matters stand. Two ropes extend BEHIND the gentleman in the middle and for extra good luck we tied him in one of them. but still it runs around in back of him."

To gentleman in center.

"When I say 'One-two-three-WALK' I want you to step backwards two or three steps."

To men holding the tapes.

"And when you hear me say WALK I want you to pull hard. Hold onto the tapes and pull. Are you ready gentlemen?"

You should be standing a little to the right of walker and behind tapes. You can get to the position by walking around assistant on right side of stage. The main idea, of course, is to stand so you do not obstruct the view of the trick.

"It is said of Teddy Roosevelt that when he went walking he would often set out in a straight line and hew to the line in spite of obstacles. He would go over fences and through houses. But Teddy had nothing on the gentleman here. I'll show you a walker. One--two--three--WALK."

Man walks backwards, men on ends pull, thread breaks and tapes come out stretched in front of the walker.

"See, the gentleman has walked right through the tapes."

To walker.

"I congratulate you, sir. You are an excellent walker. No sense going around a block when you can cut right through, is there?"

Take tapes from other two gentlemen.

ANOTHER TAPES RELEASE

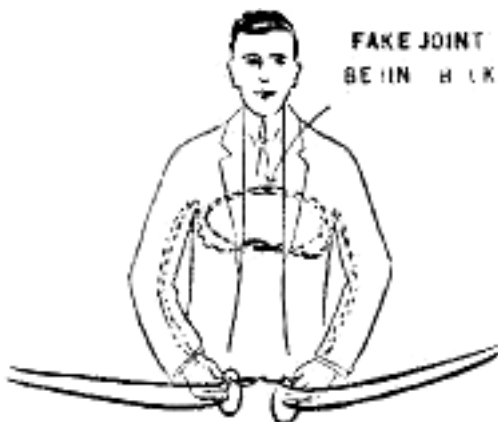


Figure 48

Effects with this tape principle are practically endless, and a bit of thought will show you new ways of working. An effective way is to have tapes prepared with thread and folded back on each other so as to form fake joint. Then place tapes under a man's coat (joint behind his back) and bring the tapes around in front and tie a single knot. Tapes are then threaded through each sleeve. A ring is placed in each of the gentleman's hands and tapes threaded through each ring, respectively. A single knot is made with a tape from each side, and ends given to two spectators to hold. See Figure 48.

Upon pulling tapes they free themselves and become stretched out before gentleman in middle. If thread does not easily break just reach up under coat and break it.

Another way is first to thread rings on tapes then go through the routine above. Performer reaches up under coat and removes rings then has tapes drawn out. All this is done while gentleman is wearing his coat.

The Japanese magicians have a way of doing the tape release in which several persons are threaded on the tapes. In their hands the effect is very puzzling.

LESSON 8

1--A piece of red tissue paper about twelve inches square is examined and rolled into a ball. This is given to a spectator to hold. Performer now asks several members of the audience to write any numbers of three digits each on a card. Another spectator is requested to add these and call out the total. Performer then says he will transfer this number to the ball of tissue paper. The ball is unrolled and there is found the number called out.

2--A piece of examined paper is placed in an empty envelope by a member of the audience. The envelope is sealed and given to a spectator to hold. Performer takes a card and writes on it numbers called out by several spectators. These are added together. Envelope is torn open and the numbers of the sum are found to be cut out of the paper.

3--Two envelopes are shown empty. On one is written the word Bank. Performer borrows a dollar bill, telling owner to remember number on it, and puts bill in the envelope marked Bank. He gives this envelope to a spectator to hold. Magician writes a check for a dollar, places it in the other envelope, and gives this to another spectator. Performer shows how rapid banking can be done and checks cashed without bothering anyone. The two envelopes are opened and the check and the bill are found to have changed places.

A handwritten signature in cursive script that reads "Harlan Tarbell". The signature is written in black ink and features a large, sweeping flourish over the top of the name.

TARBELL SYSTEM, INCORPORATED, Chicago.

(7-22)

LESSON 8

THE RELATION OF MAGIC TO OTHER SCIENCES

Magic is made light of and dismissed as foolishness by some people, but it is fortunate that there are few of these people. If these people were well informed, they would hold no such opinion of Magic. Those who are learned know that Magic was really the fount of almost all knowledge. With the tremendous significance attached to it in the annals of history, Magic cannot be dismissed with a shrug. It must be credited with more than just the distinction of being entertaining. One's researches must go deep to understand the Mystic Art thoroughly. We must realize that although Magic is now an entertaining art, it was the root from which sprang some of our great sciences.

I have traced for you the History of Magic in its various phases, Magic's Relation to Religion and to the Art of Medicine. In this lesson I will complete my outline of the background of the Mystic Art by discussing for you Magic's Relation to the Sciences of Astronomy, Chemistry, Pharmacy and Physics.

Astrology -- Foundation for Astronomy

Astrology is the pseudo-science of the stars and planets, which was the foundation for our modern science of Astronomy. When the peoples of antiquity conceived of the idea that God has made these planets as His perfect works and set them on high in the heavens, the Astrological system began. Starting with worship of the celestial bodies and the attributing to them of magical powers, the next step in Astrology was to classify the whole world into divisions which were supposedly under the influence of certain planets.

Different parts of the human body, different animals, plants, metals, and different countries were designated as under the influence of certain planets. This developed into a very complicated planetary system built up on magical beliefs. In Lesson 6 I told about the belief in the magic influence of the planets in the Art of Medicine. The Astrological system covers far more than the Medical Art, however; within the scope of its magical influences lie many, many factors in human life.

To make this clear to you, I will take the Planet Mars and give you an outline of its widespread Astrological influence:

Magic Influence of M a r s

Mars is a masculine, nocturnal, hot and dry planet of the fiery division, the author of strife. One born under Mars is short, strongly made, has large bones, ruddy complexion,

red or sandy hair, quick, sharp eyes, and round, bold face. If a strong character, this person will be courageous, unafraid, careless of life. If weak in character, this person will be a trumpeter of his own fame, fond of quarrels and fighting and given to oppression. Nero of Rome was of this type.

This planet was believed to rule the head, face, left ear, and the sense of smell. Diseases: plague, fevers, wounds from iron or steel, injuries by poison, and evil effects from anger. Herbs and plants: mustard, radish, all pungent and thorny plants. Gems: bloodstone, ruby, and garnet. Minerals: iron, arsenic, sulphur. Animals: mastiff, wolf, tiger, and all savage beasts. Birds hawk, vulture, and all birds of prey. Weather: thunder and lightning, and all strange phenomena. Kingdoms: Lombardy and Bavaria. Cities: Jerusalem and Rome. It is the ruling planet for soldiers, surgeons, barbers, and butchers. Places: slaughter-houses, battlefields, brick kilns, blacksmiths' shops. Friends: all the planets except the Moon and Jupiter. Color is red and Angel is Samael.

You can easily see how this system developed. Mars was a planet of strength and power. The god, Mars, was designated as the god of War. Naturally those minerals, plants, those weather conditions and those professions which indicated power and forcefulness and strength were put under the influence of this planet. The old magical beliefs in the elements, in the plants, etc., had merely been arranged and systematized into the pseudo-science of Astrology.

Modern Development

From this system grew our modern scientific Astronomy, which has released the science of the planets from magical beliefs. Astrology, however, still exists and is believed in by many people. It is especially known today as the Horoscope, which predicts from the time of a person's birth what his future will be because of the influence of the particular planet under which he was born.

Alchemy – Foundation for Chemistry

Astrology with its magical origin was the foundation of another pseudo-science, Alchemy. The division of the metals among the planets led to the belief that the metals were formed by the influence of a certain planet for each -- thus the same matter under the rays of Saturn became lead, under those of Jupiter, tin, and under those of Venus, copper, under certain influence of the Moon it became silver, and by power of the sun it became gold.

Alchemy dealt primarily with the discovery of the properties of matter – how certain matter came into being and what it was composed of. It was, however, bound up with Magic. It was believed that the spirits in the planets controlled these metals and the Alchemist was believed to have supernatural and mysterious powers.

The purposes of Alchemy were:

1 - Discovery of the philosopher's stone, which would create and multiply gold.

2 - Making of an alkahest or universal solvent.

3 - Composition of an infallible, universal remedy, called the elixir of life.

The philosopher's stone, it was believed, if found, would reduce all matter to its perfect form. It applied to plants, animals, earth and stone, and even to spirits. It would transform the basest metals into silver and gold, and flint into precious rubies and diamonds. It would make all the world -- even the remote parts and secret hidden caves -- visible to the holder of the stone.

The universal solvent was believed to be capable of dissolving all metals, even gold, and thus if it were found it would aid the Alchemist in discovering what the metals were formed of and would enable him to transmute or change them into purer form. This universal solvent was later exposed as ridiculous, for if this solvent were universal, what vessel would hold it?

The elixir of life was supposed to be a red medicine which would give long life and perfect health to the user. There were two problems attached to this mystery, however. Not only must the elixir be discovered, but the method of using it must also be found. It was believed to be so powerful that if used wrong, it would dissolve the whole body. A number of vague writings have been left us on this subject. Some of the philosophers believed that they had found this elixir and left prescriptions for making it. These formulae, however, are so vague and depend so much on magic that we poor mortals must go on unknowing.

These pseudo-sciences which I have discussed began with Magic and were, so closely bound up with it for centuries that all the secrecy and mysteriousness of Magic clung to the pseudo-sciences. Later when the real Sciences of Chemistry, of Astronomy developed, they were freed from magical beliefs and were given openly to the public. Though the secrecy was done away with, some of the atmosphere of the supernatural still clung to these sciences in the minds of people.

Science of Pharmacy

Pharmacy was, of course, an outgrowth of Chemistry and Medicine. First, it was allied with Medicine and Astrology and Magic. Then with the development of Alchemy and finally of Chemistry, it was placed on a scientific basis.

Science of Physics

The Science of Physics -- that which deals with mechanics, light, heat, and sound; in short, that which deals with the physical influences in the world -- cannot be definitely traced back to Magic for its origin. However, we can believe that as Magic opened the way to an understanding of nature and caused men to search for knowledge, and thus was the tree from which sprang the other branches of the Sciences, so the searching, at least, for other Sciences

-- Physics, Optics, and others -- had its origin with Magic. We do know that Roger Bacon, as I brought to your attention in the first lesson, studied the sciences and did much to develop the Science of Optics. Yet Roger Bacon was regarded as a Magician, and Optics, though since known to be a science not dependent on Magic, was then regarded as part of the Mystic Art.

It is astounding when we stop to consider the development of our great sciences and the understanding of the world which they bring to us, and then realize that all this had its origin in Magic -- Magic which was to human beings the most tremendous influence in life and which to us now is the most entertaining of all arts.

* * * * *

MAGIC IS EDUCATIONAL

The great sciences for which Magic was the foundation are now the foundation for Magic. The whole Art is closely allied with these sciences, and delving into the mysteries of Magic leads you into some study of the sciences. Magic uses physics, mechanics, optics, electricity, chemistry, psychology in getting its effects. As you learn Magic, you learn something about these sciences. The people of ancient times developed the foundation for them through their belief in Magic, and now you, working from the opposite angle, will reach out into the sciences to gain your understanding of Magic.

The knowledge you get through your study of Magic will, of course, add much to your store of learning and will help you very much in your business, in your social life, or in the Profession of Magic.

The tricks in Magic depend on the sciences. Most tricks depend on optics and the physical science of light, heat, sound; others depend on mechanics; some on electricity; and all depend on psychology for their effect. You have, no doubt, some understanding of this already from the few lessons which you have studied. You will realize this more and more as you proceed with your studies.

Increases Thinking Powers

Aside from this educational material which Magic gives you, it does something else for you. It broadens your mind and increases your thinking powers to an extent which you will find invaluable in every walk of life. It is only natural, of course, that Magic should do this. You know already that it requires concentration and real thinking to learn it. This is wonderful training for your mind. And then when you are performing, it requires quick thinking and thinking of a number of things at once.

Mastering Magic gives you the additional rewards of making you alert and wide-awake and keen of mind --

qualities which you must have to be a real Magician. You know from your studies I am sure, how Magic does this. You have found the tricks very simple in method, yet you have realized too that in spite of their simplicity, you cannot do them well until you have mastered the principles and the moves and the fundamentals and can present them in a finished manner.

You know that to be able to do this you must be alert and must think quickly and clearly. You gain this ability from Magic itself - for what Magic requires of you, it gives to you. By this I mean -- Magic requires accurate knowledge and snappy thinking on your part, and it teaches you to fulfill these requirements.

* * * * *

LESSON 8

In this lesson we work on mathematical principles and effects. You will find the principles useful in performing other effects. And the experiments themselves, are well suited to parlor, club, or stage performance.

MYSTERY OF THE TRAVELING NUMBERS

EFFECT:

Performer shows a piece of red tissue paper on both sides and holds it to the light to prove that it is unprepared. He rolls this into a ball and gives it to a spectator to hold. Performer now takes a small white card and shows it on both sides. Then he asks a spectator to write a number of three digits, such as 342 or 569, on the card. Then in rotation, four more spectators are asked to write such numbers on the card under each other. A sixth member of the audience is requested to add the five numbers and write the sum. Magician calls attention to the fact that the tissue paper was unprepared and that the numbers were written from free choice and the sum was not known to him beforehand. In spite of all this, he causes the numbers of the sum to become imprinted on the tissue paper. The spectator who has been holding ball of tissue paper is asked to unroll it, and the numbers of the sum are found written there in black ink.

PARAPHERNALIA:

- 1--A sheet of red tissue paper, twelve inches square.
- 2--Another sheet of red tissue paper the same size with the numbers 2573 printed plainly on it in black ink. See Figure 1.

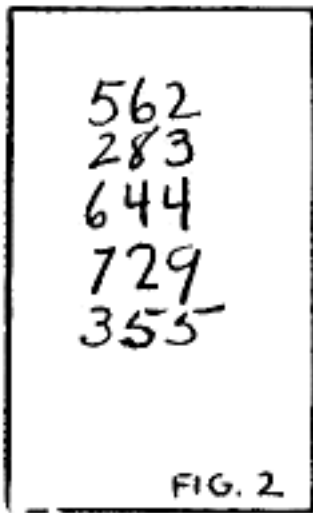
(8-5)



2573

FIG. 1

3--A small white card about 2 x 3 1/2 inches. On one side write the following numbers in pencil as illustrated in Figure 2. Try to make each number look as though it had been written by a different person.



562
283
644
729
355

4--A book, to be used as a support for writing on card.

5--A lead pencil.

SECRET AND PATTERN:

To Prepare:

Roll tissue paper with 2573 on it into a small ball and place in right coat pocket.

Place plain sheet of tissue folded up rather small in same pocket.

Put the small card with numbers written on it also in same pocket.

Have book handy on a table near you.

To Perform:

Put hand into right coat pocket. Take blank sheet of tissue paper and finger palm the other sheet which is rolled into a ball. In your lesson on the torn and restored paper napkin you learned how to finger palm a ball of paper.

"In performing my next experiment I am going to make use of a plain piece of tissue paper. I want you to notice that it is plain on both sides. I hold it here in front of this light so that you can see through it too. Just a piece of tissue paper such as you would use to wrap Christmas packages."

Show both sides of paper. If there is a light near, hold paper in front of it. If this is not convenient, just show paper freely. The back of the right hand is toward the audience to conceal ball of paper. Use left hand freely in showing paper.

"For the time being, I will roll it into a small ball."

Roll paper into small ball. Now work as you did in the torn and restored napkin trick. Manipulate the palmed ball of paper up into fingers and hold the two balls as one.

"It would take a good acrobat or contortionist to roll himself up any smaller, wouldn't it?"

Palm away the plain ball with right hand. Let right hand drop to side. Prepared ball is held in left hand on level with your chest.

"Now to place the little ball of paper in good company, Madam, I am going to ask you to be so kind as to take care of this little one for a few moments."

Give prepared ball to a lady to hold.

"Keep it in sight all the time so that the audience can see it."

Reach into right coat pocket for the white card and leave the palmed ball of plain paper in pocket. Take card out with blank side toward audience. They must never know about numbers written on the back of card.

"We will use this plain white card next. Same color on both sides."

NOW COMES AN IMPORTANT MOVE.

You apparently show both sides of the card to the audience but in reality show only one. You must practice this in front of your mirror until you are able to perform the move smoothly and quickly. The illusion is perfect when the move is performed properly.

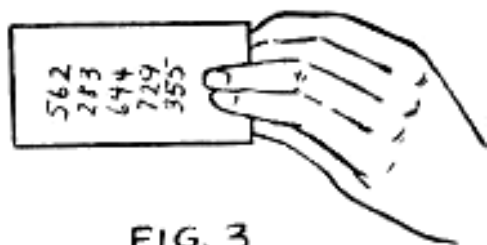


FIG. 3

Hold card as in illustration 3. Blank side of card is toward audience. Back of hand is toward you. First and second fingers in back and thumb, third and fourth fingers in front of card.



FIG. 4

Hold card in front of you a little below level of chin and in front of left shoulder, as in Figure 4.

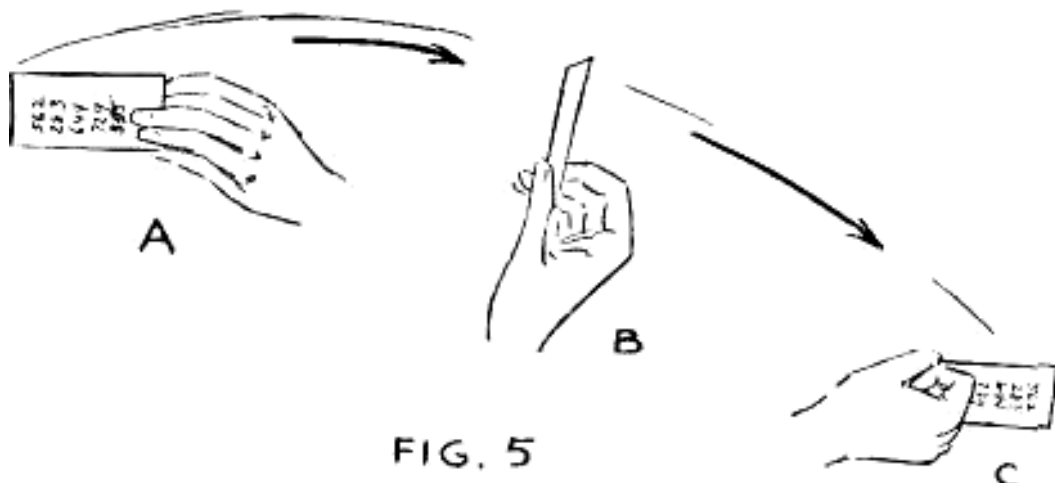


FIG. 5

Swing right hand toward the right. As you do this, the card is brought to a sharp angle in the vision of the audience, but it is not turned enough to expose the numbers on the back. Move illustrated in Figure 5.



FIG. 6

When arm is about halfway down in the movement, force card downward with right thumb. Do this quickly. See Figure 6.



FIG. 7

Continue movement until hand is thrust out at side as in illustration 7. The long movement from left shoulder across body and out to side and then the quick movement of turning card downward suddenly with thumb serves to give the illusion of turning card over and showing it on both sides.

The whole movement should be done quickly and smoothly without hesitation -- just as you would do if you really showed both sides of card.

"We should have a portable writing desk. This book will answer the purpose."

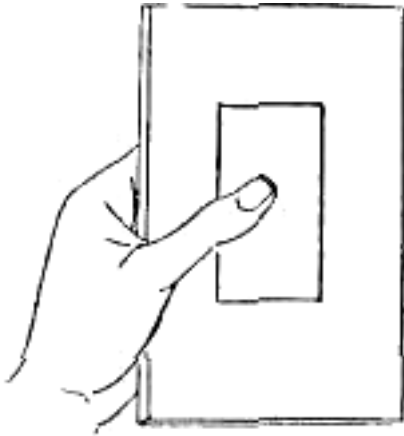


FIG 8

Pick up book and place card on it, blank side up, as illustrated in Figure 8.

Reach into pocket and take out pencil.

"I would like to have someone write any number of three digits on this card. A number like 343, 864, and so on -- any number that you choose. Write it so that several more may be placed beneath it and so that the total may be secured."

Give book and card to a spectator. When he or she has written first number, give book and card to another member of the audience and have him write another number under the first.

"And you, sir, will you write a number of three digits right beneath this one."

Continue until five people have written numbers.

WARNING:

Have people who write these numbers on one side of room and not too close to each other.

Now move to other side of room, carrying book and card. You must be in a position where there is no one behind you. Hold book up for a moment so that card is not visible to audience. Book is held in both hands. The left hand holds book firmly. The third, fourth, and fifth fingers of right hand are under book; the finger and thumb hold the card.

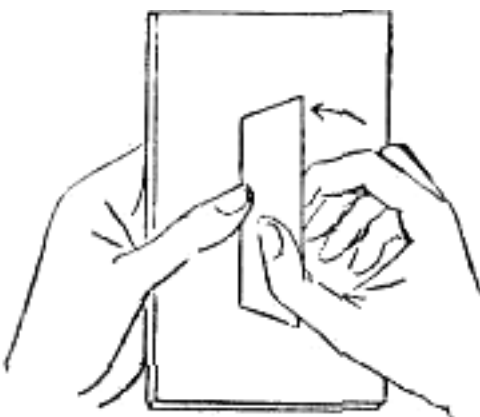


FIG. 9

Under cover of book, turn card over quickly with forefinger and thumb of right hand. Movement is toward left, as in Figure 9. This brings prepared side of card to top.

Hold card in place with thumb of left hand and remove right hand from book and card entirely. Take pencil and draw a line under the figures. Give card and book to someone on opposite side of room from where spectators are who wrote down the numbers. Ask this spectator to add the numbers and write down the sum.

"You look like a very good mathematician, sir. Would you mind just adding up the numbers and writing the sum beneath them?"

When this is done, take up book and card and hold in left hand. Put pencil in upper coat or vest pocket.

"The sum is two thousand, five hundred, and seventy-three. Two - five - seven - three. Is that correct, sir? Will you all remember the numbers -- two, five, seven, three? Now I am going to show you a very odd experiment in legerdemain. Let us first sum up the situation. The young lady here holds a blank piece of tissue paper. Several numbers have been written on this card. You each had your own free choice of numbers. I could not possibly have known what you were going to write. The gentleman has added up the numbers and the sum is 2573. What I intend to do is to cause the spirit of the numbers to travel and write themselves one at a time on the ball of tissue paper that the lady holds."

Place thumb and first and second fingers of right hand on card, apparently picking up the numbers and then throwing it in the direction of the ball of paper.

"Two!"

Repeat movement.

"Five! Pardon me, Madam, do you feel anything? Nothing? Perhaps you are not sensitive to spirits."

Repeat throwing movement.

"Seven! Certainly you felt the number go that time."

Repeat throwing movement.

"Three! Now, if you will please unroll the ball of paper . . ."

Lady unrolls paper.

"Do we find that the spirits imprinted the numbers well on the paper?"

After lady has unrolled paper and looked at it take it from her and spread it out well. Hold it up so that all of audience can see the numbers.

"There, just as I said, the sum two - five - seven - three has been carried mysteriously to the paper. That is what they call the handwriting on the wall."

NOTE: You can change forged numbers by varying numbers you write on card. I seldom use the same numbers twice.

* * * * *

THE SPIRIT MATHEMATICIAN

This gives you another method of obtaining a definite sum from your audience, one which you have determined on beforehand.

EFFECT:

Performer shows a plain piece of white paper. Spectator is asked to examine it and then place it in an empty envelope and seal the envelope. Performer then asks various members of the audience to call out numbers. These he writes on a card. The card is given to a spectator, who is requested to add the numbers and call out the sum. The envelope is then opened and the numbers of the sum are found to be cut out of the piece of paper.

PARAPHERNALIA:

- 1--A piece of plain, white bond paper, 3 x 5 inches.
- 2--Another piece of bond paper the same size with the number 45 cut out of it. You can do this easily with a sharp penknife. See Figure 10. Save the numbers that have been cut out as well as the paper from which they have been cut.
- 3--A small card on which to write numbers.
- 4--A book to use as a support for writing.
- 5--A pencil.
- 6--A pen-knife or small dagger.
- 7--A special envelope.

We will designate this envelope throughout the course as the DOUBLE ENVELOPE.

This is a simple but clever piece of paraphernalia which can be used in many magical effects.

It is very easy to make.

With it you can materialize, vanish, or transform flat articles like cards, pieces of paper, etc.--that is, you can cause them to appear, to disappear, or to change form.

HOW TO MAKE:

Take two plain manilla envelopes. These must be of good weight so that they are as nearly opaque as possible. Or you may use colored envelopes that are opaque.

Cut the front side with the flap from one of the envelopes, about one-sixteenth of an inch from the bottom and side edges. This leaves you a flat piece of paper with a flap as shown in illustration 11.

(8-10)

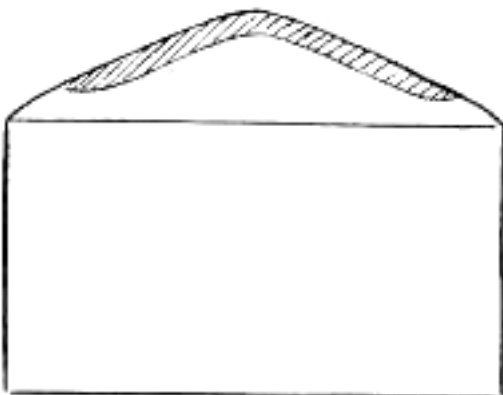
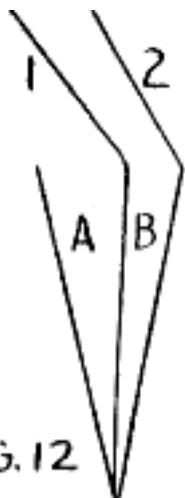


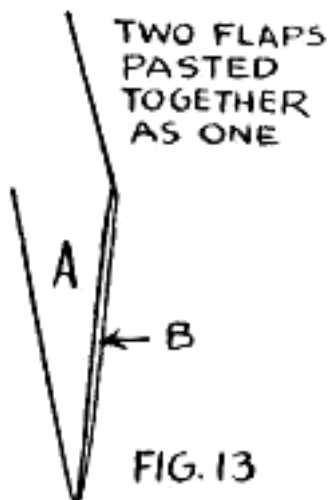
FIG. 11

Insert this piece of paper and flap into the other envelope so that the gummed flaps both face the same way and fit well together. This insert acts as a wall.



We shall call the space in front of insert A and the space behind it B. See Fig. 12.

FIG. 12



In space B place the piece of paper with the number 45 cut out of it and the cut-out numbers 4 and 5 also. Wet the gummed portion of flap 2 and paste it onto flap 1, as illustrated in Figure 13. Sometimes I glue down the whole flap, not just the edge.

Open up envelope. To all appearances it looks like an ordinary envelope with nothing in it. Audience will never suspect that it has a false partition and a prepared paper in it.

To Perform:

Have prepared envelope, piece of paper, book, card, pencil, and knife or dagger handy on nearby table.

Pick up piece of paper and envelope.

"There are some effects in magic that I do not know whether to believe or not, myself. They are just as puzzling to me as to my audiences. I do them and then wonder how I did them. Here is a trick that I have often wondered about. I have here an empty envelope and a piece of paper. Would you, sir, be kind enough to examine this piece of paper?"

Give paper to gentleman.

"Quite ordinary, is it not? And yet, I sometimes think quite extraordinary. I picked it up in a quaint old book store. Found several sheets of it in an old second-hand book I bought. One of these sheets had written across it these words, 'Someday a magician will use this paper. Prize it highly for you may never obtain any more of it.' Rather odd, don't you think? I wish I knew who put the paper in the book. In the back of this same book were several envelopes and this knife (or dagger). This is one of the envelopes. I could find nothing queer about them except that they were empty. I thought that maybe there might be money in them. Can you, sir, see any money?"

Show inside of envelope to spectator. Envelope looks empty, of course.

"And will you please place this piece of paper inside of the envelope yourself?"

Spectator places paper inside and you seal the envelope.

"Let us seal it inside, then run this knife (or small dagger) through the envelope. I will just set it here in full view."

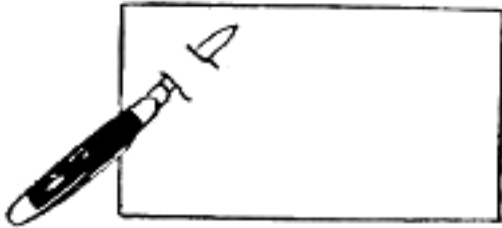


FIG. 14

Run blade of knife or dagger through front side of envelope as in Figure 14. Set envelope up against something on the table in full view of the audience, or give to someone to hold. Spectator should hold knife (or dagger) with envelope suspended on it.

Pick up card and book and pencil from table.

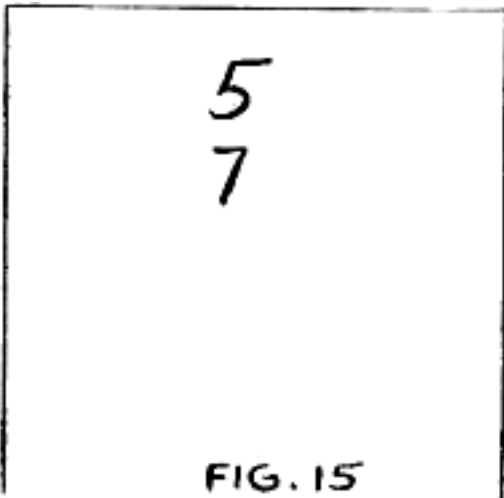
"I do not need to tell you that this is a book, this is a card. . ."

Show both sides of book and card.

"And this is a pencil. How good are you at mathematics? I suppose all of us can count to ten. That's all we have to do is to count to ten. We have nine numbers to select from. I want several of you to call out numbers and I will write them on this card. Call them slowly that I can write them down. All right, sir, start the ball rolling. Just call any number from one to nine."

Someone calls number—say, for instance, five. You write it down.

"All right, another number from someone else. You may call any number or repeat one that has already been called."



Put down the next number called—say, seven. See Figure 15.

IMPORTANT:

AFTER YOU HAVE WRITTEN DOWN THREE NUMBERS ON THE CARD, LEAVE A SPACE FOR A NUMBER TO BE WRITTEN IN LATER, as shown in Figure 16.

Then proceed writing down the numbers called. But as you write the numbers, ADD THEM MENTALLY UNTIL YOU REACH A SUM BETWEEN 36 and 45.

If the sum should happen to be 36, you may call for another number. The most that this number could be is nine so that you run no risk of exceeding the sum you want—45. If you reach a sum greater than 36, however, call for no more numbers.

5
7
1

4
9
6
3
7

FIG. 16

5
7
1
3
4
9
6
3
7

FIG. 17

Let us presume that the numbers which have been called are those written in the top list. The sum so far is 42.

To get the sum of 45, which is on the prepared paper, add the number three in the space left in the list. Then draw a line under the figures. See Figure 17.

"Now, let me read these numbers and each one may check up on his number. 5-7-1-3-4-9-6-3-7."

These should be read rather quickly.

"Will you please add them up?"

Give card to someone to add numbers. When he has done that, ask for the answer.

"And what is the total? 45. Thank you. Now, remember this. Several of you called out numbers which you selected yourselves. We checked up on them and this gentleman (or lady) added these numbers and found the total to be 45. You said 45, did you not? Well, here is where the mystery starts."

Pick up envelope.

"A few moments ago the gentleman there put a piece of paper in this envelope, and I inserted this phantom knife (or dagger)."

Remove knife.

Holding envelope with flap side toward you, tear off the end and reach into Space B (nearest audience). As you do this, push middle partition firmly against side of envelope nearest you. Tip envelope over a little and take out the prepared paper and the cut-out figures. While doing this, you may walk up to a spectator if you are performing in a parlor or club.

"If you will note, sir, some strange influence has been at work on the paper and has cut out with the blade of a phantom knife (or dagger) the same sum that the gentleman found your numbers totaled-45."

Hold up paper so that all can see it, then hold up the numbers 4 and 5.

"The envelope is empty, not even a trace of the spirit of the phantom knife (or dagger)-or even foot-prints."

Show inside of envelope, passing it around rather hurriedly and at a safe distance from audience. If inner partition is held tight against rear side of envelope, this is easy to do without detection.

"Will you, sir, please examine the paper and the numbers. Rather odd, isn't it? Maybe some day I will solve the secret and then be able to tell you how it is done."

NOTE:

With a little concentration, you should have no trouble in adding the numbers mentally. From time to time vary the number you want forced. You may use any number from 35 to 50.

Suppose you want to use 41 and have that cut out of the prepared piece of paper. Assume that various members of the audience give you the following numbers:

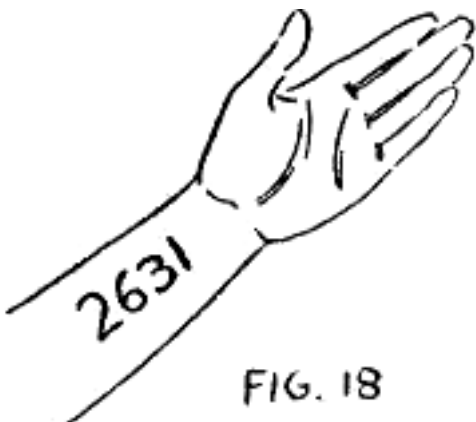
3		
5		
9	That's	8
		17
4		21
3		24
8		32
7		39

As 41 is the number to be FORCED, simply place the number 2 between 4 and 9 and you have raised your sum to 41.

Both methods of forcing a number, as described in the preceding two tricks, you will find very useful. They may be used interchangeably in both tricks. You may use the ball of tissue paper in this second trick and the cut paper in the first trick.

THE NUMBERS ON THE ARM

An interesting variation of these mathematical tricks is this: Write the number to be forced on the left forearm with a brush, soft stick, or pencil dipped in milk or lemon juice, or you may use a piece of soap. Let this dry well on the arm.



After numbers have been written on the card and the sum determined by a spectator, pick up a piece of paper or the same card and burn it in a dish. Rub the ashes over the forearm and the number will stand out in black on the arm, as in Fig. 18. The ashes will adhere to the milk, lemon juice, or soap.

RAPID BANKING

EFFECT:

Performer shows one envelope with the word Bank printed on it and a plain envelope, both empty. Performer borrows a

dollar bill and tells owner to remember number on bill for identification. He then places this bill in the empty envelope marked Bank. Taking out his check book, he writes himself a check for \$1, places it in the other envelope, and seals the envelope. Magician tells of the difficulty one encounters in trying to get checks cashed while traveling and says he is fortunate in always being able to get checks cashed instantly. He tears open the envelope marked Bank and there, instead of the dollar bill, is the check. He opens the other envelope and finds the dollar bill there. He returns it to the owner and asks him to identify it by number.

PARAPHERNALIA:

1--Two DOUBLE ENVELOPES, as described in last effect, preferably one of one color and one of another color.

2--A dollar bill, not too old or too new.

3--Check book.

4--Pen to write check.

5--A dollar bill borrowed from audience.

SECRET AND PATTERN:

To Prepare:

On one of the envelopes letter the word BANK. See Fig. 19.

In Space B, between partition and front of envelope, place a check written out for one dollar.

In the plain envelope in Space B, place the dollar bill. Just before doing so commit to memory the last three numbers and letter on the bill--for instance, let us say that they are 735A.

Now seal the flaps 1 and 2 together on each envelope so that they will look like ordinary unprepared envelopes.

Have check book and pen in pocket.

To Perform:

Start with patter:

"Have you ever had any difficulty in getting checks cashed? Well, I have, especially among strangers. In order to overcome this difficulty, I sought out a way of cashing my own checks. I did this by establishing a rapid-fire connection with the bank. Perhaps you would like to know how I do this. First of all, I wish to borrow a dollar bill, not too old and not too new."



FIG. 19

There are three kinds of dollar bills so try to get the nearest match to the kind of bill you have sealed in the double envelope. If a new bill is offered to you, say-

"I really hate to take such a nice new dollar bill away from a man on pay day."

If the bill offered is too old and frayed, say--

"This bill is pretty far gone. Haven't you one with more endurance. It is going to travel far and should be sturdy and a little younger."

The bill with the eagle is perhaps the most common type. If you do not get that kind, however, the others will look similar enough.

Take bill from spectator.

"A kind-hearted gentleman who thinks I look honest lends me a dollar bill without interest. Now, let's remember the number on the bill so that we can identify it later. Put these last three numbers and letter down-7, 3, 5, A."

These are the numbers on the bill in the envelope, but the audience thinks that you are reading the numbers of the bill you hold in your hands.

Pick up envelope marked Bank.

"This envelope will represent the bank. In it I will put to my credit the sum of one dollar-the gentleman's dollar- and then close the doors of the bank."

Fold bill in half as you did the one in the other envelope. Show envelope empty and then you put the bill into envelope or have a spectator do it. Seal envelope and place it upright in full view of every one or give it to a spectator to hold.

"Next, I will write myself a nice check."

Take check book from pocket, open it, and take pen from pocket.

"A nice check for the sum of one dollar, which I have in the bank. I could make it out for two dollars-but I am afraid the bank wouldn't appreciate it."

Write check to yourself for one dollar, making it out exactly the way you did the check you have sealed in secret compartment of BANK envelope.

"Let us place the check in this other envelope."

Show envelope empty, fold check and place inside. Seal envelope and place, upright on table or give to someone to hold in plain view.

"Now, for the secret system of banking. I need money. Do I walk up to some strange hotel clerk and ask him for it? Not

much. I might not get it. So I just say, 'Tar-ix-a-cum, Tar-ix-a-co. Oh, where, oh, where, does my money go?' Then my money flies out of the bank and comes to me."

Pick up BANK envelope, tear it open so that the middle partition rests on back side of envelope, reach in and take out check. Hold envelope with opening toward audience and open end down. After check is out, give audience a hurried look into envelope.

"See, my check has already arrived in the bank and the dollar has flown."

Give check to spectator or drop on table after showing it freely.

"Taking the other envelope in which I originally placed the check. . ."

Take other envelope, tear it open, and take out dollar bill. Show inside of envelope hurriedly. Be careful with this envelope, too, to have inner partition well up against the back side of envelope.

"We find the dollar bill which I deposited in the bank. We can easily check up this bill by the number."

Look at number and show it to audience.

"The last three numbers—7, 3, 5, A. Was that not correct, sir? Thanks for the bill."

Return bill to owner. He thinks he is getting his original bill back, but he is really getting yours. Dispose of envelopes so that audience will not get a chance to inspect them too closely. In laying down envelopes, be sure to put them down with opening away from audience so there will be no chance of their seeing the secret partition in them.

ANOTHER RUSE which I occasionally use is to mark the check in the envelope Number 7. Then in writing the other check before the audience I ask someone to call out any number between 5 and 10. Through the working of a psychological law, the number called by the spectator most often will be 7. If seven is called, say, 'I will number this check 7. Remember you had your choice of numbers. It will help you to identify the check.'

Then when you take duplicate check from envelope, call particular attention to the identification number.

If someone calls out a number other than 7, say 8 -- you may just say, "Eight—ah a magic number. I shall place this check in the keeping of eight spirits", and pay no more attention to the number.

For my professional brethren, let me say that I often have check in BANK envelope stamped with PAID mark that banks use when check is cashed; and then I prove that it is the same check I started with by the "Torn corner identification." For

the beginner, let me say that I shall explain torn corner work later on in the course. You are not quite ready for it at this stage.



TARBELL SYSTEM, INCORPORATED, Chicago.

* * * * *

Lesson 9

In this lesson I initiate you into some excellent card tricks. I know you are tremendously interested in card effects. These I give you now are only the beginning of a list of many amazing card experiments which I have planned for you.

1 - A card is drawn from the deck by a spectator, replaced, deck is shuffled and put into the cardboard box. Flap of box is closed. Performer has spectator tie case onto left hand with a handkerchief. On command the chosen card rises from ease and drops to floor.

2 - A sealed card mystery. Deck is given to spectator to shuffle. Spectator then removes three cards from pack and places them in three envelopes. These envelopes are sealed into larger envelopes. Rest of pack is cut into two parts. Spectator chooses one envelope. Card is removed. Spectator then removes top cards of two sections of cut pack of cards and finds that one bears the suit of the chosen card and the other bears the number.

3 - The Psychologist's Dream. Deck is divided into two portions. One part is spread out and spectator thinks of a card in this part. Part is squared and laid on table. Performer has spectator draw card from other section of deck and place it in performer's pocket without looking at it. Then spectator is asked to look through part of deck from which he mentally selected a card and finds that that card is gone. Performer takes the card out of his pocket and it proves to be the card that spectator thought of.

THE PRINCIPLES OF CARD EFFECTS

Card tricks fill an important place in the realm of Magic. These tricks are based on sleight of hand and on mechanical arrangements.

Sleight of hand is a great art. It involves very definite principles which must be practiced a great deal. I give you here the principles which form the foundation for the card effects depending on sleights. These principles are not difficult to master, but they do require careful thought, study and practice. These principles are the backbone of Magic, and once you master them you have a wonderful foundation for building your card effects.

In Card Magic are also included the fancy sleights and flourishes that some Magicians use. These really belong to the field of the juggler, however, not to the magician. My aim is to teach you Magic which mystifies and not jugglery which is merely a mechanical accomplishment gained from years of practice.

Practice these principles faithfully. You will be delighted to notice your improvement in performing each time you try. I list here the principles which you must master to perform the effects given you in this lesson. The explanations of the working of the principles are embodied in the explanations of the effects in their proper places:

- 1 - The simplified pass.
- 2 - The false shuffle.
- 3 - The double card lift.
- 4 - The slip change.
- 5 - The palming of a card.

The mechanical arrangements involved in the effects are:

- 1 - Production of selected card from closed card case.
- 2 - The slit corner envelope.
- 3 - Doubling first card in fan.

I hope you realize the importance of this lesson and the need for your absolutely mastering it before you perform any of the effects. You are not expected to be able to do these card tricks with only a little practice. Some of the effects in earlier lessons required only a short time of study and you were able to perform them well, but you must put real study and practice into these effects. There are many people who know card tricks, but they do not know these which depend on principles. And so if you train yourself to be a finished card performer, you place yourself way above the ordinary amateur.

* * * * *

THE RISING CARD ESCAPE

Rising card tricks have been very popular in Magic. There are many methods of producing the effect, but most of them are mechanical arrangements. The method I give you is impromptu, so that you can perform it with an ordinary deck

of cards at any time and in any place. In this method you use some sleight of hand and the very simple mechanical arrangement of closing the card case.

EFFECT:

Spectator draws a card from deck of playing cards and shows it to audience. He replaces it in deck and shuffles it in. Performer then places deck in cardboard case and closes the flap down. Then he requests spectator to tie case onto empty right hand with a handkerchief. Upon magician's command the selected card rises from the deck, apparently through the case.

PARAPHERNALIA:

1--A deck of playing cards.

In card Magic you will find the best cards to use are Bicycle or Bee Cards. Some magicians like Steamboat cards. The favorite Steamboat pack is the one with the red and black lined backs, which gives a brown effect. Blue back cards are best, however, because the blue color is least detectable in sleights. A new deck is preferable to an old one. When you borrow a deck, however, you must use what you get.

2--A borrowed handkerchief.

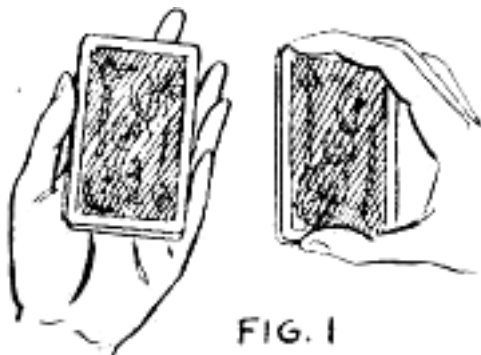
SECRET AND PATTERN:

To Perform: Remove cards from case and give to spectator to shuffle.

"Please, sir, take out any card you choose and give me the rest of the deck."

Take cards from spectator.

"Remember the card you have selected, and if you care to, you may show it to a neighbor or two. Now return your card to the middle of the deck."



Cut deck into two equal portions. To do this, hold deck in left hand, backs of cards up. Place thumb of right hand at bottom edge of cards and first, second, and third fingers at top of deck. It is then easy to lift up the top half of deck. See Figure 1.

Have spectator place his card on the lower half of deck.



THE SIMPLIFIED PASS:

Place top half of deck which is in right hand on lower half which is in left hand. As you do so insert little finger of left hand between the two halves of deck, as in Figure 2.

The front part of deck is allowed to come together in an ordinary manner, but the back part is divided by the little finger. Audience thinks two halves have been brought together and selected card lost in center of deck.

Practice this much carefully before the mirror until you can do this naturally and insert your little finger so that no one can notice it.

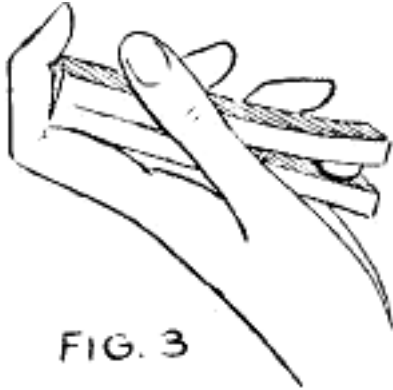


FIG. 3

Figure 3 shows the position of your left hand now. Your thumb is at the left of the pack, your first finger is at the front end, your second and third fingers are at the right, and your little finger is at the back between the two sections of the deck.

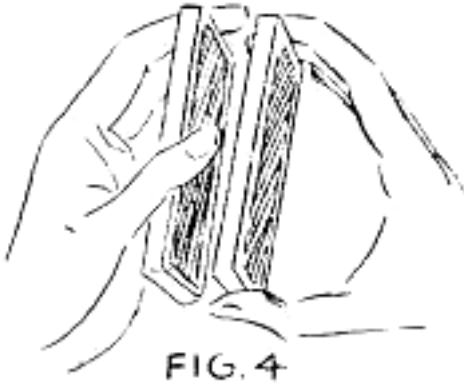


FIG. 4

Turn left hand toward right bringing thumb end up.

Using little finger as a lever, push top half of deck out a little and grasp it with right hand. See Figure 4.

Your object is to get the selected card to the top of the deck. This card is now the top card on the lower section of the deck which you have divided by little finger of left hand. To accomplish this you perform THE SIMPLIFIED PASS in this manner:



FIG. 5

With right hand place top half in front of lower half of deck and shuffle cards toward front of deck, faces of cards toward audience. See Figure 5. This must be all done with one movement. Do not put the top pile of cards down in front of the others and then start shuffling. Do your shuffling right from the movement of the Pass.

This is called a FALSE SHUFFLE to keep selected card at top of deck - explanation of this follows:

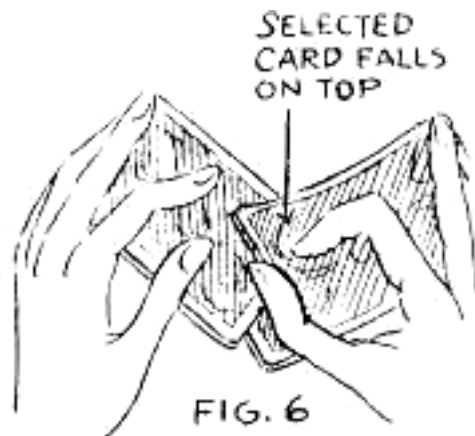


FIG. 6

THE FALSE SHUFFLE:

In this type of false shuffling the point is to actually shuffle the cards but not to place any cards over the top card. See Figure 6. Shuffle toward the front of the deck.

If you do a riffle shuffle, riffle two halves of deck into each other but BE SURE THAT YOU LET TOP CARD FALL ON TOP WHEN THROUGH.

You must learn to do this shuffle naturally.

Audience now believes that card was returned to middle of deck and its position lost by shuffling. To prove card is lost in deck another ruse is used.

DOUBLE CARD LIFT:

Chosen card is at top of deck, but you are going to prove that it is not there.

Hold deck in left hand, backs of cards up. With right thumb lift up lower left corner of "two" top cards, as illustrated in Figure 7.

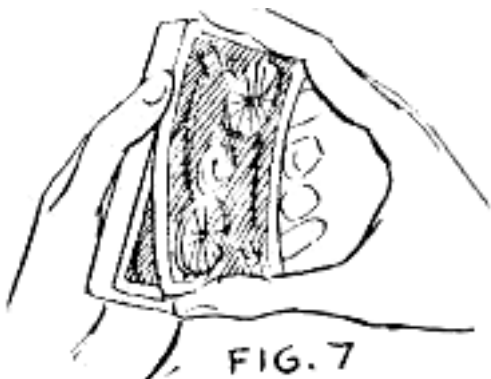


FIG. 7

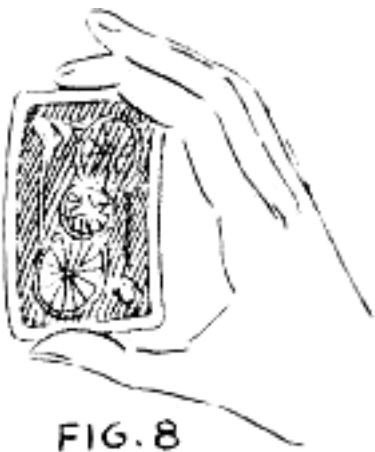


FIG. 8

Pick up the two top cards and show them as one. See Figure 8. To the audience it looks like you are holding only one card. And that card is not the selected card.

"By the way, the top card did not happen to be your card, did it? No? Then it has! been lost somewhere in the pack in the shuffle."

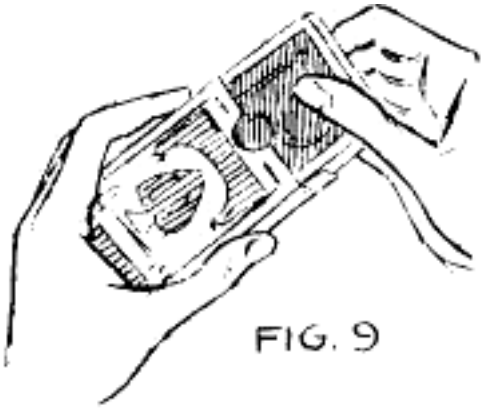


FIG. 9

After showing card, return the two to the top of the deck.

Pick up card case and show it empty. You may give it to spectator for examination.

Place deck in case with face of cards toward flap of box, as illustrated in Figure 9.

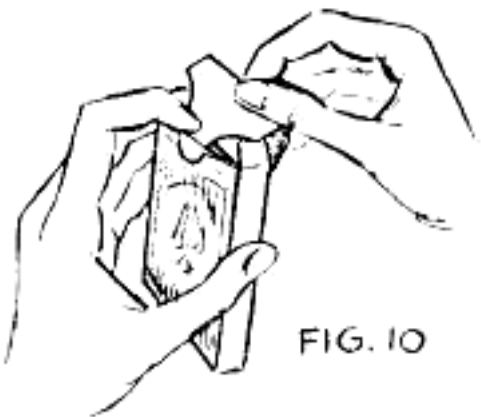


FIG. 10

Push down the two small side flaps of case, then bring large flap over cards, and insert it apparently enclosing whole deck in the case. This is what you really do. Place the tip of left index finger on top of selected card and pull it back about an eighth of an inch from rest of pack. See Figure 10. This allows enough space into which to force the flap of card case. Push flap down.

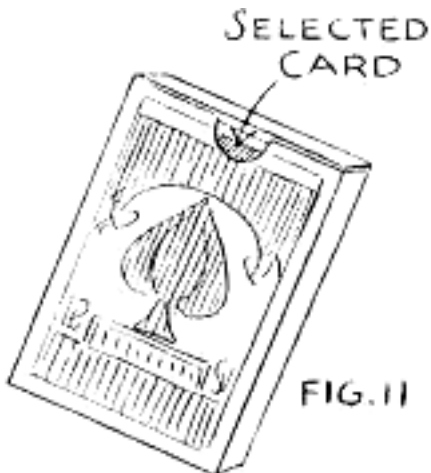


FIG. 11

You now have chosen card between back of box and the flap. See Figure 11. As box and card are same color the box can be thrown about rather carelessly and can be shown hurriedly without fear of detection. The audience will not suspect that you have not enclosed all of the cards in the case.

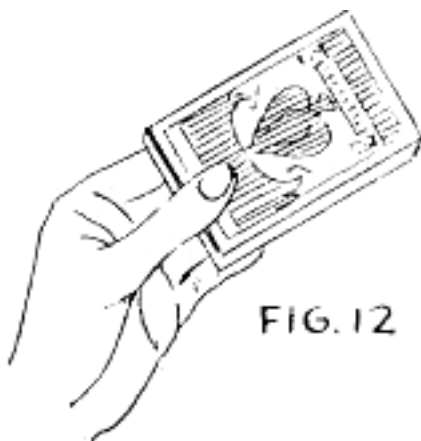


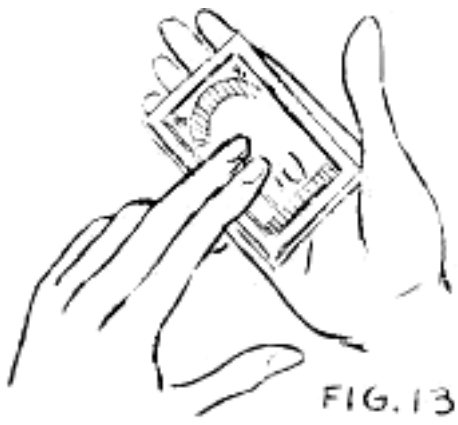
FIG. 12

You may show case at close range by holding thumb of left hand over part where card shows. See Figure 12. Show case freely to prove that cards are really enclosed in it.

"I should now like to borrow a handkerchief."

Ask spectator who lends handkerchief to roll it up rope fashion.

"Please roll the handkerchief rope fashion. Now will you please tie the deck of cards onto the palm of my right hand?"



Show right hand freely, both sides, spreading fingers wide apart. Also show both sides of case. Then place case on right palm with part showing selected card against the hand and toward tips of fingers, as in Figure 13.

(9-4)

"Tie it rather tight so that it will not slip."



FIG. 14

Spectator ties handkerchief around case and hand, knotting it at the back, as illustrated in Figure 14.

"Let me convince you again that there are no cards in my hand or outside of the case."

With left hand lift up edge of case, covering selected card with first two fingers, to show audience that there is nothing between case and hand. Lift up lower end of case also.

"Now, sir, will you please tell me what card you selected? The Jack of Spades? Thank you. (We will assume here that the selected card was the Jack of Spades, but any other card would do just as well.) Well, the Jack of Spades is somewhere in this card jail. You know he is a slippery fellow. Would you mind calling him? Say, 'Here. Jack, here, Jack. Come here, Jack'"



FIG. 15

When spectator calls, you place second finger of right hand against card in case and push card slowly out of case.

Push card out about three-quarters of an inch, then release it and return finger to top of case and push card up again a little way. Then repeat this motion. If it is done properly, card will appear to rise slowly out of box. Keep the motion smooth, not jerky and your effect will be good. See Figure 15.

"Prison walls do not a prison make -- and out comes the Jack."

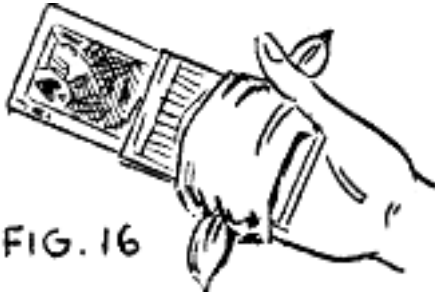


FIG. 16

When the Jack has risen almost entirely out of the box, as in Figure 16, take it out with left hand and give it to spectator or lay it on the table.

"This is your card, is it not? And the rest are still in the deck and snugly tucked into the box."

Slip case from hand and remove handkerchief. Show case on both sides. Open flap, remove deck, and fan deck (spread it out fanwise) to show cards freely. Return borrowed handkerchief.

"The moral of which is -- it is a wise card that does not sleep fifty-two in a bed."

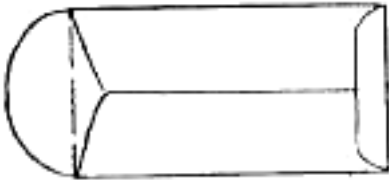
* * * * *

SEALED CARD MYSTERY

EFFECT:

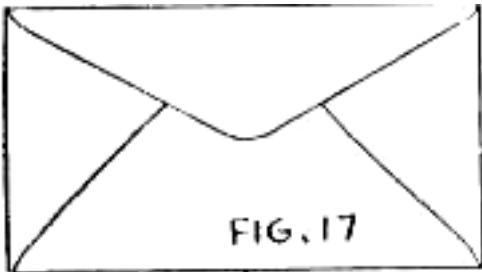
Performer gives deck to spectator to shuffle thoroughly and then to select a card. Spectator passes the deck to two other spectators who in turn each select a card. Performer does not touch pack during selection of cards. Each spectator is asked to place his card in a small envelope and seal it in. Then each seals small envelope into a larger envelope. Performer divides deck into two sections. He shows top card on each section. Then one of the envelopes is selected. Spectator is asked to lift off top card of each section and it is found that they have changed and that one of the cards shows the suit and the other the number of the selected card. Envelope is torn open and the prophesied card is found therein.

FIG. 17-A



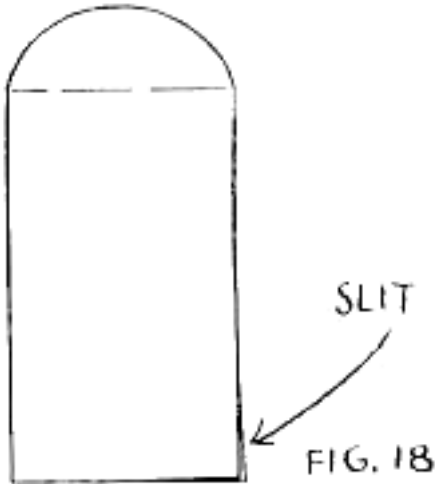
PARAPHERNALIA:

1--Three small opaque manilla envelopes, such as used for church collections or pay envelopes - size: 2 1/2 x 4 1/2 inches.



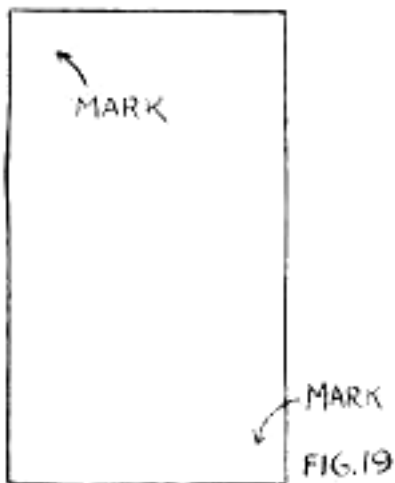
2--Three standard size manilla envelopes - about 6 1/2 x 3 1/2 inches. See Figures 17 and 17A.

3--A deck of playing cards.



SECRET AND PATTEN:

To Prepare: Take one of the small envelopes. With the scissors cut off a very fine edge on the lower right side of envelope - cut up about 1 1/4 inches from bottom and about 3/4 inch along bottom. See Figure 18.



On one of the large envelopes put a pencil dot at the upper left corner and at the lower right corner on both sides. See Figure 19. This is done to enable you to identify this envelope at a glance from among the three envelopes.

To Perform: Have envelopes on table nearby. Take deck of cards in hands and fan them to show that they are ordinary playing cards. Never say in words, "I have here an ordinary pack of playing cards." Use the POWER OF SUGGESTION by fanning cards.

"Will you, sir, please shuffle this pack of playing cards. Shuffle them well."

Give deck to spectator to shuffle.

"Now remove any card, look at it, but do not let me see it. Then pass the deck to someone else."

Spectator selects card and passes deck to another member of the audience.

"Take any card out and remember it. Do not let me see it. Then you give the deck to someone else, too."

Card is removed and deck passed to a third spectator.

"In a like manner take out any card, remember it, and do not let me see it. I will take the deck, if you please."

Third card is removed by third spectator. You take deck and place it in full view on table. Pick up an unprepared small envelope and hold in left hand.

"Will the person who drew the first card please place it face down, so that I cannot see it, in this envelope?"

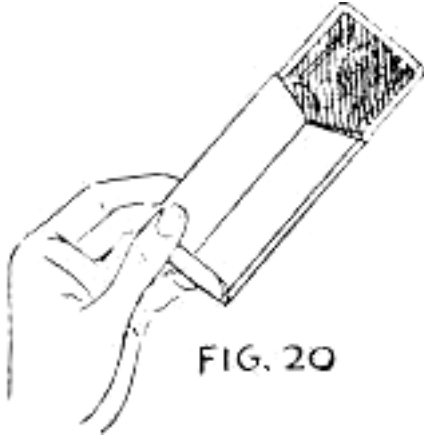


FIG. 20

Hold envelope toward spectator so that card can be inserted, as in Figure 20. Wet flap and seal. Take a large envelope from table, open it, and drop small envelope with card into it. Then you request spectator to seal large envelope.

"Will you, please, seal the envelope and hold it for a while?"

Now pick up prepared small envelope. Hold slit corner together with thumb and first finger of left hand. Hold envelope toward second spectator as you did the first one.

"And will you, please, place your card in this other envelope, face down so that I cannot see it?"

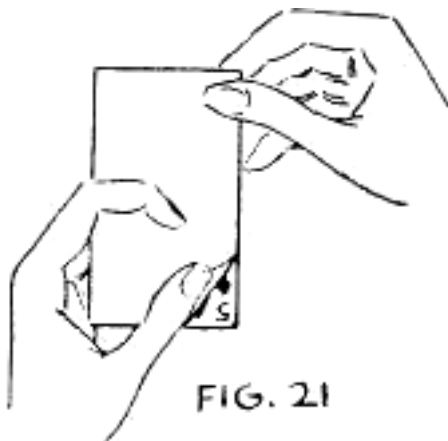


FIG. 21

Second spectator inserts his card. With first or second finger of your right hand, push card well against bottom of envelope. Wet flap of envelope and turn it toward audience. As you seal down the flap with right hand, WITH LEFT THUMB LIFT UP SLIT CORNER OF ENVELOPE AND LOOK AT NUMBER AND SUIT OF CARD. See Figure 21.

You can see at a glance what the card is inside of the envelope. Let us say it is the 5 of spades. Allow corner flap to fall back in place. Audience is watching you seal flap of envelope, and if you hold the envelope tilted upward, they will never suspect what you are doing, as they cannot see rear of envelope.

Take prepared large envelope – the one with the dots in the corners – from table.

"Again we will seal the card and envelope in still another envelope."

You place envelope into larger one and seal it yourself.

"And I will have the lady (or gentleman) here hold it."

Give envelope to spectator to hold. Take other small envelope from pocket.

"We will have the last card sealed into the envelope also."

Card is placed in envelope by spectator and flap of envelope is sealed.

"And then we will place it also in the larger envelope."

Small envelope is placed in third large envelope and flap of envelope sealed.

"Please hold the envelope."

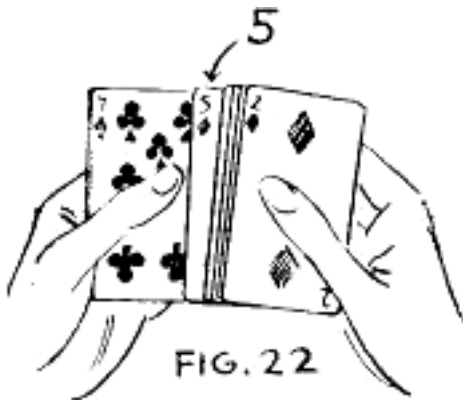


FIG. 22

Go back to table. Pick up deck of cards. Fan it open slightly so that you can look through it hurriedly. You must now locate two cards, one with the suit and the other with the number of the card which you have in the slit envelope. We are assuming that the card in the slit envelope is the 5 spot of Spades. Look through deck quickly for a 5 spot of any suit and when you have found it place index finger of right hand back of it. See Figure 22.

Continue running through cards until you come to a spade. When you do, lift it out with as little movement as possible and slip it in front of index finger of right hand. This places the cards in the following order:

Lower section of deck held in left hand.

A spade card of any number.

A 5 spot card of any suit.

Upper section of deck held in right hand.

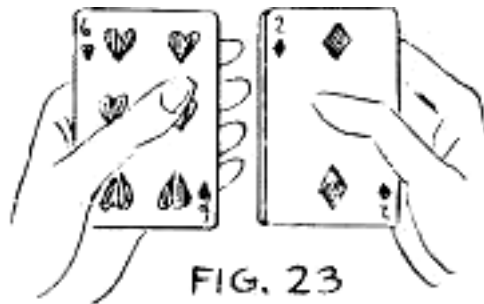


FIG. 23

Right index finger is held between lower and upper sections of deck.

Now divide pack into two portions, holding them about a half inch from each other, as in Figure 23.

"Guess that this is a full pack. Oh, well, it doesn't matter."

Place section of deck in right hand under that in left hand and square up cards.

The spade card and the 5 spot are now on the top of the pack. In Card Magic, the top of the pack is always the side with backs of cards up and bottom is side with faces of cards showing. Turn pack over and riffle shuffle it -- giving it a FALSE SHUFFLE, so that two top cards remain on top.

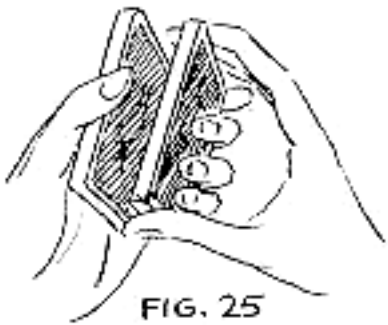


FIG. 25

Now hold pack in position shown in Figure 25.

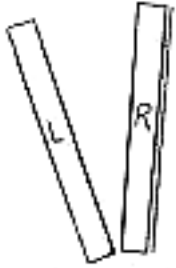


FIG 26

THE SLIP CHANGE:

Keeping lower edge of deck together, open up upper edge of deck about in the middle. Figure 26. Press hard with left fingers against top card of right-hand section of deck.

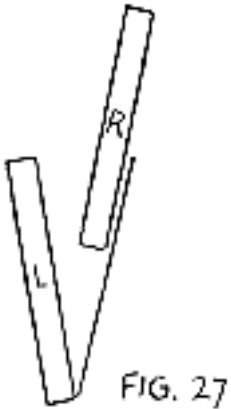


FIG. 27

Lift out all of right-hand section of deck with the exception of top card, Figure 27. Hold this card securely with left fingers.

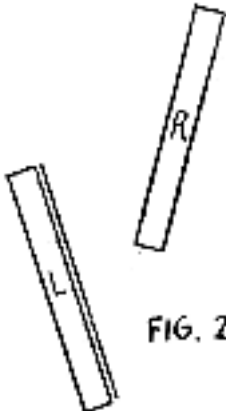


FIG. 28

When you remove right-hand section of deck with right hand, top card automatically falls against the cards in left hand and so becomes the top card of the left-hand half of deck. Figure 28-

This move in which a card on one section of a deck is slipped over onto the top of the other section is called THE SLIP CHANGE- Practice this over and over again. Keep a firm grip on card to be slipped with left fingers. You must acquire ease and quickness in performing this move. Also study the ANGLE OF VISIBILITY for the move before your mirror.

Place the two sections of deck on table, faces of cards down.

"Let us see what card is on top of this packet."

Take left-hand packet and do the DOUBLE CARD LIFT, lifting the two top cards as one. Call out the card and replace. The top card is really a spade, but the audience is not aware of this.

"Queen of hearts." (Or whatever the "second", card may be.)

Replace pack on table. Do the DOUBLE CARD LIFT on other section of deck.

"The top card on the other packet is the ten of diamonds." (Or whatever the "second" card in this half of the deck may be.)

Replace double card on pile again.

"Do you believe in fortune-telling? Fortune-telling with cards? Whether you do or not, I want to show you something peculiar about card prophecies. Will someone take all three of the envelopes, please – those which my good friends are holding, and mix them up well?"

Someone collects three envelopes and mixes them up.

"Now, spread them out and I will take one."

Reach over and take the one with the dots marked on it.

"I guess this one is as good as any. I wonder what card is in it. I don't suppose the Old Nick, himself, knows. But that is where fortune-telling with cards comes in. On the table we have two piles of cards. On the one is the Queen of Hearts, on the other is the Ten of Diamonds. We will ask the spirit of the great gypsy fortune teller to come down and tell us with these cards which card is in the envelope. First, good gypsy, tell us the suit. Is it a heart, a spade, a club, or a diamond? Hark, I hear foot prints of the spook."

Lift off top card on left-hand pile. It is the Spade card. Show it to the audience.

"A Spade. Now tell us, kind spirit, what is the number on the card? Is it a deuce, a six spot, a King – or what?"

Lift off 5 spot on right hand section.

"A 5 spot. Then the card in the envelope is the FIVE OF SPADES. Who selected the 5 of Spades? You, sir? Thank you."

Tear open large envelope quickly. Remove smaller envelope, carefully concealing slit corner with fingers of left hand. Tear open flap end, then place forefinger of right hand inside envelope and rip open side and bottom, allowing card to come out. If you have a knife handy, you may slit side and bottom of envelope with it. This destroys the evidence of the slit corner.

Hold up card and show it so that all can see it.

"The 5 of Spades is correct. Please tear open the other envelopes and I will replace the cards in the pack."

Envelopes are torn open by spectators and cards given to performer. Magician shows them and calls them in order to convince audience that different cards were placed in each envelope.

Pick up sections of deck from table, replace selected cards, and square up the deck.

NOTE: When you call out cards, put vigor into your voice. Be sincere and convincing in your manner. BE POSITIVE. Do not hesitate or stammer or you will lose your effect. Here again the POWER OF SUGGESTION applies. If you are positive in your actions, you will convince your audience and put over your tricks.

THE SLIT CORNER ENVELOPE:

The envelope with the slit corner may be used for experiments in which you do card mind-reading. You can read any card placed in the envelope very easily by simply raising the slit end of the envelope.

You may try a Mind-Reading effect of this nature: Have a selected card placed in the envelope. Follow directions given in preceding effect for sealing flap of envelope and at the same time looking at the card. Then hold envelope to forehead and name the card in it. Then slit envelope open as directed in preceding effect, to destroy evidence, and show card.

In mental effects of this kind, you must use SHOWMANSHIP to work effectively. For instance, in this effect, do not simply say, "The card in the envelope is the Two of Diamonds."

Work your patter up to something like this, "I get an impression - the card is a red one - it vibrates like a heart - No, it is a Diamond - the Two of Diamonds."

I give you this suggestion because I want you to start working up your own effects from the principles I have taught you. You will find it fascinating to originate your experiments and your patter. Start now to try to do this.

* * * * *

A PSYCHOLOGICAL IMPOSSIBILITY

EFFECT:

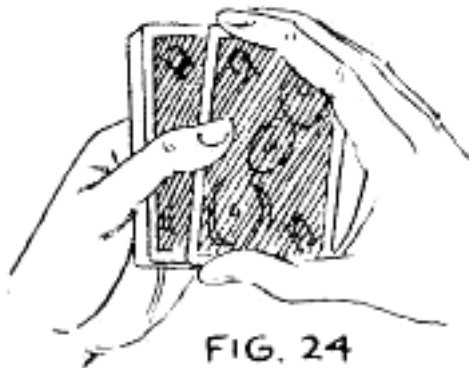
Performer picks up a number of cards from a shuffled deck, fans them out, and asks someone to select a card. Spectator who makes the selection is asked to remember which number from the end this card is. Performer closes up cards and places them on table. He then picks up remainder of pack and asks another spectator to remove any card but not to look at it. Magician places this card in his pocket. First spectator then tells what number from the end of first section of deck his card was. Magician looks through this first pile and finds that card is not there. He removes the card which was selected from the second pile from his pocket and first spectator finds that this is the card which he selected mentally from the first pile.

PARAPHERNALIA:

1--A deck of playing cards.

SECRET AND PATTERN:

To Perform: Have deck of cards well shuffled.



Pick off about a third of the deck, as in Figure 24, and place the rest of the deck in full view on the table.

Place the third of the deck in left hand.

(9-11)

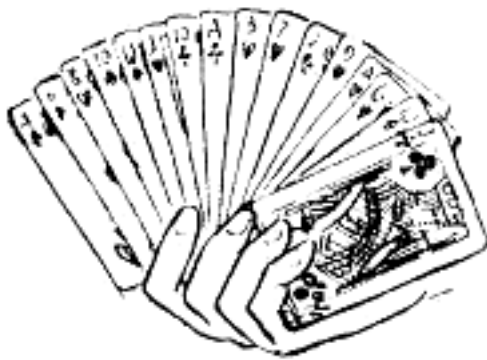


FIG. 29

With right thumb lift up lower left corner of TWO TOP CARDS about an inch. Move the two cards over to the right as ONE. Then fan the rest of the pack to the left with left hand. It appears that you are showing all the cards in the pack to the audience, but in reality the last card in the fan is a double card (two cards together.) Your left side should be turned toward audience. See Figure 29.

"I have here a number of cards spread fanwise and I want someone to think of a card and remember the position of it in the pack - that is, what number it is from the top. For instance, starting from the end (Performer's right side), one, two, three, four, five, six, the sixth card is the Jack of Hearts. Or, for instance, you choose the seventh -- the Ten of Clubs. Choose any card, but remember the number it is from the end. Have you thought of a card? Have you it well in mind, and its position from the end? All right. Then I will just square up these cards and lay them on the table."

After spectator has thought of card, square up the little pile and place it in full view on the table. Then show both hands empty, both sides, fingers wide apart.

Because of the extra card behind the first one which spectator saw, the card he selected is one card farther from the end than he thinks. If spectator mentally chose the sixth card, this card is really seventh from the end, etc.

"Now, watch me carefully. I pick up the other pile of cards and ask you, sir to take them in your own hands and take out any card you choose. However, do not look at it, or show it to anyone."

Spectator removes card.

"Give card to me."

Spectator gives you card.

"And I will place it in my pocket."

Holding card with back to audience in your right hand, place it in your right trousers' pocket.

"Now square up the pile of cards in your hand and place it on the table. We are now ready for the mental miracle or what psychologists say is an impossibility. It is the psychologists' dream."

Point to cards at right, from which spectator mentally selected a card.

"Now if I were to tell you that the card you thought of in this pile of cards is the one that was selected from this other pile and the one that I placed in my pocket -- you would think this is a pretty good trick, wouldn't you? And I assure you, too, that there are no two cards alike in the deck. Let me prove to you that what I say is true."

Pick up cards at right and hold in left hand, BACKS OF CARDS UP.

"By the way, what number from the end was your card?"

Spectator tells you - for instance, Five.

"The fifth card -- let us see."

Count cards, backs up, slowly and distinctly one at a time into the spectator's hand. When you have counted off five cards, the sixth and selected card is now the top card.



FIG. 30

Bring right hand back to pack and with thumbs of both hands slide the top card, which is the selected card, about three-eighths of an inch to the right. Lift up lower right edge of this card far enough to get first joint of little finger of left hand between it and rest of pack. Square up all the cards, leaving little finger under the top card. See Figure 30.

DO THIS WITHOUT LOOKING AT CARDS. YOU MUST LOOK AT SPECTATORS AND USE MISDIRECTION WHILE DOING THIS MOVE.

"If you thought of the fifth card, then it must be the one you have there in your hand. Look at it and see."

Point at spectator's hand with your right hand. As he looks at card, you bring your RIGHT hand over to the deck in your left hand. Raise top card with little finger of left hand and propel it into right palm. See Figure 31.



FIG. 31

PALMING OF A CARD:

Curl fingers of right hand slightly over card. This will hold card in right palm, as in Figure 32.

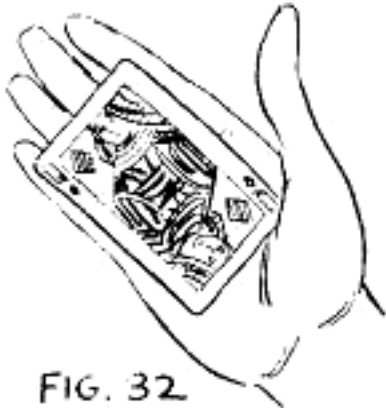


FIG. 32

Proficiency in palming a card is essential to your success in Magic. Practice it. You must keep back of hand to audience and keep card screened from view, as in Figure 33. Remember NATURALNESS of the hand and ANGLES OF VISIBILITY.

"Is that your card?"

You refer, of course, to the fifth card, which he has in his hand.

"No? Then, what was your card?"

Spectator calls out the selected card, say the Queen of Diamonds. You repeat,

"The Queen of Diamonds."

With card palmed in right hand reach suddenly into right trousers' pocket where you placed second selected card.



FIG. 33

Now remove the Queen of Diamonds from your pocket. This is, of course, the card which you just palmed in your right hand and placed in your pocket. The other card remains there.

Use showmanship in producing the Queen from your pocket. Bring out the top edge and slowly turn it around so that audience can see it. Put an element of suspense into the producing of the card.

"Then I was right after all. You see the card you thought of in one pack was the one you selected from the other pack and which I placed in my pocket."

Dispose of card still in pocket by placing whole deck in pocket and then bringing it out again with card or by palming card and bringing it out and placing with rest of deck, or leave it there if not in the way until an opportunity comes of secretly removing it. Do not be in a hurry to get card out of pocket.



TARBELL SYSTEM, INCORPORATED, Chicago.

* * * * *

LESSON 10

You have reached a certain goal by this time in your study of the Profession of Magic. I know you have been performing informally with the effects which I have given you already, but now you are ready to give a real performance.

Lesson 10 is a wonderful lesson. It teaches you:

1 -- SHOWMANSHIP --

Details involved in the proper presentation of a program.

2 -- HOW TO ARRANGE SEVERAL PROGRAMS --

Programs to suit you, to suit the audience and to suit the occasion.

3 -- How to present a complete program or show with what you have so far learned.

LESSON 10

In the first nine lessons of this course I have given you many principles and effects on which the Magic Art is based. If you have practiced faithfully, and I am sure you have because the work is so fascinating, you are now ready to give a real performance. I want this -- your first public appearance as a Magician -- to be so successful that it will fire you with enthusiasm and make you realize how great are the rewards of the study of Magic.

The reason that I give you this lesson at this point is that I believe you are now ready to begin to break into public work. Of course, I expect you to make only a small beginning. You may invite some friends in for an evening and entertain them with your Magic, or you may arrange with some friend to entertain a group at his home. Then if you gain a little confidence in your ability, you may offer your services to entertain your club or lodge, or the church club. The Rotary club, The Kiwanians, The Lions, and various other organizations are constantly on the lookout for entertainers, and you may use them to get started in public work.

It might be well for you to do this first entertaining without charge to give you experience. Then when you think you are worth it, you may charge for your work. I want you to be making money with your Magic as soon as you can, and I believe that before you have finished the course you will have made up several times its cost by your performances.

Now for the necessary preliminaries before I discuss with you the actual presentation of your program:

CONFIDENCE AND ENTHUSIASM

You must have CONFIDENCE in yourself, first of all, to present a program properly. Review the preceding Nine Lessons. It will do you a world of good to read over again my discussions of various subjects, such as the Power of Suggestion, the Credulity of People, etc. This will do much for you in the way of giving you confidence, for an understanding of the way in which the human mind works gives you the confidence of knowing how to deal with it.

Be sure of your tricks and you need have no fear that you will fail. Remember that you are the master -- that no one else in your audience knows the secrets of your effects -- and that they cannot help but be mystified.

Start with your own family or a small group of friends in your home for your first audience. Performing before those you know will give you experience and confidence, and in time you will reach the stage where you are as much at home before a thousand people as you are before one.

Forget yourself and throw yourself into your performance, with ENTHUSIASM. If you love Magic you must bring that love, in the form of enthusiasm, into your performance. You know how contagious enthusiasm is. Your audience will catch the spark and will be alive with interest because of your enthusiasm.

Confidence in yourself and enthusiasm will, of course, do much to ward off stage fright. Absolute mastery of yourself while before an audience will, however, come only with experience. Whatever you do. BEWARE OF STAGE FRIGHT REMEDIES. I remember an instance of what a Stage Fright Chaser did many years ago. I was doing a magic show in the old town hall. One of the performers on the program bought a bottle of this Stage Fright Chaser. The directions said to take it in a dose of three to five drops in a half glass of water. To be certain of its working, this man took a tea-spoonful. Needless to say, we had a sick performer on our hands. All such remedies affect the heart and you must avoid them.

RADIATE GOOD-WILL AND PLEASANTNESS

You must start "right off the bat" with a kindly feeling for every person in your audience. You know from your own experience that when you like a person and show it, that person reciprocates your friendliness. So it is with your audience. Radiate GOOD-WILL AND PLEASANTNESS and you will get it in return from your audience. You will ward off antagonism. From the first moment you are before your audience you must win them over.

A performer is always sensitive to antagonism toward him in his audience and it handicaps him in his work. If by your attitude you gain the friendliness of the audience, you have half the battle won. You have put your spectators in a receptive mood and consequently your effects go over big.

DIGNITY - NO CHEAPNESS

You must remember, however, not to overdo in your effort to please your audience. ALWAYS KEEP YOUR DIGNITY. This does not mean that you must be stiff and aloof -- that would never do; but it means that you must never lower your standards and do something that will cause people to lose respect for you.

In your bearing, in your manner, and in your speech, never resort to cheapness or undue smartness in your zeal to make a hit. A little reserve along with your pleasantness will make a hundred-fold better impression with your spectators than boisterousness.

In line with this, let me say a word about your speech. WATCH YOUR ENGLISH. This is tremendously important in your success. When you are among educated people, you must be very careful not to get this reaction from them, "Yes, his tricks were good, but how he did abuse the English language!" and when you are among very ignorant people, you must be correct in your speech so that they will look up to you and admire you.

Remember always to speak distinctly.

In Magic the trick is the thing that you want people talking about. You must raise no counter-influences to distract their attention from your experiments, as poor English will do.

APPEARANCE

I need not tell you the importance of APPEARANCE. Our first judgment of a person is based entirely on his appearance. If you present the wrong kind of appearance the impression you convey to the audience is very detrimental to you. If you present the right kind of appearance you open the way for yourself immediately.

Always be neat. Have your clothes well pressed and your shoes shined, wear a clean collar and a good tie. Have your hair cut and be clean shaven. Wear a suit that best becomes you. A business suit is ideal for the usual magical performances. At formal affairs the tuxedo or dress suit is in order but it must fit nicely so that it will not cause comment. I will discuss dress in a future lesson when we get to stage performances.

PERSONALITY AND MAGNETISM

You must have technique in your work -- you must be a finished performer -- BUT even above this, you must have PERSONALITY AND MAGNETISM. In business, in the professions, on the stage, those people triumph who triumph on the side of personality. For instance, take a performer on the stage. You know that you have seen actors who are extremely clever and make a big hit -- yet their acts are very simple and perhaps what they do almost anyone else could do. The secret lies in their emphasizing their personalities. It isn't what they do, but how they do it.

Your job is to sell your personality to your audience -- to make people like you. Then, regardless of what you do to entertain them, they will be pleased with your efforts.

So, in the beginning, play up Personal Magnetism. Then as you perfect your technique with practice and experience, success cannot fail you.

* * * * *

SHOWMANSHIP

To become a Master of Showmanship you must be inspired with the spirit of being a Magician. Do not merely play at the part, but use the POWER OF SUGGESTION on yourself to make you really feel and fill the part.

Dress the part -- act the part -- do everything to create personal magnetism and a favorable impression -- avoid all disturbing elements -- and STUDY SHOWMANSHIP.

Now, let us analyze this tremendous factor in Magic -- Showmanship. It means the ability to put ROMANCE, MYSTERY, THE ELEMENT OF SUSPENSE, INTEREST, EMOTIONAL FEELING, and EFFECTIVENESS into your performance.

The more power you have to build these elements into your work, the greater will be your rewards. Take your example

from the playwright. He puts into his plays the same principle of showmanship which you must use. He creates interest in his audience, arouses their emotions, and builds up from lesser effect to greater until he reaches a climax. And you must work in the same way.

The Showman makes a masterpiece of a commonplace trick. He clothes it properly, he studies his presentation, he stirs up his audience with interest and suspense, he puts reality into the part he is playing, he works the whole thing up to a climax.

In every-day life we find many, many instances of Showmanship. The salesman who understands Showmanship is the one who gets the orders. He knows just what to say and how to say it, what to do and how to do it to get the greatest effect. See how the advertising man plays up a commonplace article with his Showmanship and makes you hunger for it. See how a poor piece of farm land is turned into a subdivision. How the bands play! How the salesmen use their Showmanship! And how people rush to buy the wonderful property.

What Showmanship can do was brought home very forcibly to me at one time. A party of about twelve Magicians, myself included, went to see the play, "The Charlatan." Frederick Tiden was playing the part of Cagliostro, the magician, in it. We sat there delighted at the magic and illusions which he presented. When he produced a rosebush from a seed which he had planted in a glass flower-pot, we were completely mystified. Here truly was a great magician whom we had hitherto missed. After the show we met Tiden. The Cagliostro on the stage and the Tiden in the theater lobby were two different men. In the play he was a rather large, dignified elderly man of great poise and mastership. Before us he was smaller, thinner - Tiden, the artist. We went out for a bite to eat and, as usual, some of the boys performed tricks. Then Tiden was called on to perform.

"Why, boys, I'm no magician," he said. "I do not do tricks. You have me all wrong. I am just an actor."

"Oh, no," said we, "you are a magician. Didn't we see the wonderful magic you did tonight at the theater. It was marvellous. You had us gasping. Where did you get the flowers from?"

He leaned back and laughed. "Do you mean to say those tricks fooled you?" he asked.

"We admit it," the boys said.

Then Tiden gave us an excellent talk. He said that as he had been chosen to play the part of the great magician, Cagliostro, he determined to make himself feel like a great magician and really act the part. He studied what he thought Cagliostro would do in the emergencies which the play brought forth. He succeeded so remarkably in getting his effects and making the illusions seem real because of his Showmanship.

He decided that things should be produced and vanished from places which an audience would least suspect. In this instance the man who appeared most innocent of helping him was the villain. So then, Tiden thought, his best helper would

be the disturbing lawyer who opposed Cagliostro at almost every move, a skeptic who sought every way possible to undo the magician. In the eyes of the audience this lawyer and the magician were bitter enemies. In reality the lawyer in looking into the flower-pot to see that Cagliostro was not putting anything over on him, put the flowers in himself. And Tiden in his mastery of Showmanship put his effects over as if he were the greatest magician in the world.

PLAY UP YOUR INDIVIDUALITY

There is no one in all the world just exactly like you. If each of us would only realise this and capitalize on it, how successful we would be. We would give full play to our individuality instead of trying to be like other people, and we would build on our own originality.

In Magic you have the opportunity to an extent which you have in no other field to use your originality and your own individuality.

Always play up yourself as your better self. Bring out the strongest and best sides of your personality and emphasize those things which makes you a little different from other people.

BE ORIGINAL, do not be an IMITATOR. The imitator gets little credit for his work. He is known everywhere as the man who uses someone's else stuff, and whether he is good or not, he is known as an imitator. You know that an original painting is a hundred times more valuable than a copy. So it is in Magic. Originality does not mean that you must build up elaborate effects. On the contrary, the great masters work in the simplest manner. What you must do is to use Showmanship with even the simplest effects to give them the stamp of your own individuality.

Do not try to imitate the feature effects of your brother magicians. You will only bungle them and make yourself ridiculous. They have years of study and experience back of their effects and you cannot hope in such a short time to compete with them. Each of the masters has his original effects which suit his individuality. These effects, however, may not suit your individuality. So because LeRoy vanishes from a box high in the air and suddenly appears with a hat and overcoat on and burning cigarette in his mouth on the piano in the orchestra, this does not mean that you should try to do this. Because Houdini gets out of seventeen pairs of handcuffs is not a reason for your trying to imitate him. Thurston, Blackstone, Laurant, Downs, Manual - all do their feature performances in their own inimitable way. A real master does not attempt to imitate the other. He realizes that his success lies in his own individuality and originality, not in those of another man.

So perfect yourself in those things which are best adapted to you and let those who will, try to imitate. They will never get very far, while you will be building a reputation for originality.

In the beginning perform each effect exactly as I teach it to you in the course. Then as you master more and more of the principles and gain experience, you can change and add to these effects and originate new ones.

HOW TO PRESENT A PROGRAM

A little farther on in the course I will give you suggestions for several programs. You may prefer, however, to arrange an original program for yourself. If you do this, remember to choose your tricks carefully for the audience and for the occasion.

Make a list of the tricks which appeal to you most and which you seem best able to perform. Remember your dramatic effect in arranging these tricks, working up to a climax. It is best to keep your tricks in divisions, such as paper tricks in one, string tricks in another, etc. However, arrange the sequence of effects so that one blends into the other.

Paraphernalia:

As you have no assistant at this time and must present your program alone, I suggest that you secure a suitcase, about 10 x 15 inches. Put small wooden partitions in it to separate the paraphernalia for each trick. You can then arrange your materials nicely so that they are easily "gettable."

When you are working on a stage with curtains and have an opportunity to prepare for your performance, you can arrange things easily, but for club or parlor work, you will find the use of the suitcase almost a necessity.

When you come to your show, you have in your pockets, of course, those things which require working from the pocket, such as the Thumb Tip, etc. You can come in with your suitcase, place it on a table, open the top up toward audience and prop it up with a stick or have a special catch made and you are ready to begin. The top of the suitcase acts as a screen for your movements in removing paraphernalia. You have everything in order so that there is no fumbling about, looking for apparatus. Then when you are through with your performance, replace the paraphernalia which is still out, close up your suitcase, and walk away.

Arranging Your Audience:

Always try to arrange your audience in front of you. There should be an angle of 45 degrees at least from you to your spectators on extreme sides, and they should be far enough in front so that they cannot see moves which you do not want them to see.

It is not always possible, however, to arrange your audience in the ideal way. For emergency you should carry tricks with you which can be performed under difficulties.

Club work often presents great difficulties because people are all around you. You must have fool-proof tricks ready to perform at a moment's notice. Work at club luncheons is especially difficult because of the angles of visibility. Try to get a corner in which to work so that you are out of the angles of visibility of the audience.

If people insist on sitting at the sides, I tell them that they can see my work much better from the front as my

body covers so much of the effects from their view when they are at the sides.

Sometimes you can secure a parlor screen or two to close off a small stage. This will help you considerably.

Look to your lighting before you begin. The ideal lighting is from the front -- that coming from the rear is apt to expose the effects. So size up the situation from the standpoint of placing of audience and lighting and place yourself so that you may perform to the best advantage.

Do all you can to guard your secrets from detection -- for your own success in the work as well as for the good of the profession as a whole.

SUGGESTIONS FOR PROGRAMS

These programs are suitable for performances in the home, at a club, or on the stage. Shorten or lengthen the programs to suit the occasion. A program given at a luncheon, for instance, should be quite short, whereas one given at a club entertainment may be longer. You may rearrange these programs or add other effects as you like, but keep a logical harmony throughout the program.

1

1--Mystery of the Burning Cigarette (Lesson 2)

2--Comedy Version of Germaine Cord Effect. (Lesson 6)

Toss string to audience at conclusion of experiment.

3--The Spirit Mathematician (Lesson 8)

Have spectator hold envelope on knife blade.

4--Rising Card Escape. (Lesson 9)

5--A Psychological Impossibility (Lesson 9)

6--Sealed Card Mystery. Lesson 9)

7--Chinese Paper Mystery. (Lesson 4)

If convenient this may be followed up with Wintertime in China -- it never fails to make a hit. If performing in a home, you must be careful not to get things on the floor which are hard to remove.

2

1--Burning a Borrowed Handkerchief. (Lesson 2)

2--Hindoo Paper Tearing. (Lesson 5)

3--Milady's Parisienne Hat. (Lesson 5)

4--Kellar's Cut and Restored Cord. (Lesson 6)

5--Mystery of the Traveling Numbers. (Lesson 8)

6--Rapid Banking. (Lesson 8)

1--The Magic Orange. (Lesson 7)

2--Hanging Yourself with Ropes. (Lesson 7)

3--The Dissolving Coin. (Lesson 1)

4--Japanese Torn and Restored Paper Napkins and Comedy Explanation. (Lesson 4)

5--Patriotic Paper Balls. (Lesson 5)

Done with high glasses or bowls and saucers.

6--Mystery of the Traveling Numbers. (Lesson 8)

Make your program fresh and snappy. Have sufficient variety in it and present it with energy and enthusiasm. Remember always to speak very distinctly.

Your Opening Remarks. Just say a few words in opening to fit the occasion, such as:

"I take pleasure in presenting to you a few experiments in legerdemain or magic. It is oftentimes said that a magician endeavors to fool you. But really I wouldn't fool you for the world. Should things look peculiar, remember it is your own self who is looking on and seeing things. Watch me closely for the closer you watch, the closer you watch."

Learn when to quit. Most beginners are too slow in their presentation and make their programs too long. Rather than tire your audience, leave them wanting more.

Never repeat a trick. I warned you of the danger of repeating tricks in the first lesson. Turn a deaf ear to all requests and coaxing to repeat a trick. When people are mystified they invariably ask you to "do it again." And then if you repeat the trick, they look for things which you don't want them to look for, and you run great danger of being discovered.

If you must repeat at all, vary the trick or present some other effect. This will usually satisfy the audience. If you chance to come across nuisances who are disagreeably insistent, do not take them seriously, just ignore them.

Never expose a trick. You realize that your success in Magic depends on secrecy. Think of the many centuries that this Art has survived, and you, now that you are joining the ranks of the Mystics, have a responsibility and an obligation to fulfill - and that is to guard your tricks sacredly against being exposed.

It is up to you to see that no pebble, regardless of how small, is allowed to crumble out of the foundation of Magic. It is up to you to protect the principles and the effects you learn against the layman and to keep them as your very own.

How to Get Volunteers to the Stage. Sometimes it is difficult to get volunteers from the audience to come up on the stage. You can in some cases overcome this by speaking directly to certain people instead of to the audience in

general. Then if the spectator is embarrassed by stage fright, help him along in this manner. Ask him to hold a certain article for you, then to hold it up higher. Then you might say:

"Please stand up, sir, so that the man over there can see. Yes. Perhaps, if you come out into the aisle, it would be better. Fine. Just come up on the stage and all can see it."

Thus you get him to the stage step by step, and as you do this gradually, he cannot refuse.

Remember always to be courteous and respectful to people who come up to the stage to assist you. Make them feel perfectly at home. NEVER PLAY A JOKE on a spectator or do anything to make him lose confidence in you. Comedy at the expense of one in your audience is not good comedy for the Magician. Be tactful and people will be glad to help you on the platform.

How to Deal with the Wiseacres. No matter what happens, you must keep your poise. Always be a gentleman, and be the master of every situation. There is occasionally someone in an audience who tries to discourage the performer and put him in embarrassing positions – the "smart" person who will not give the performer a chance. If the magician suggests one thing, he suggests another. He also is the type who tells everyone around him how the trick is done. He is seldom, if ever right but he is very annoying, nevertheless. He acts in this manner because he wants to be in the limelight and he is doing his best to get there. You must never permit yourself to fear this person.

The audience is always with the performer. They do not like to have disturbing elements arise to interfere with the show and they will admire you if you keep cool and smile away difficulties. Make your presentation so good that even the wiseacre will admit your worth. The tricks in this course are designed to help you puzzle the "wise" ones.

Remember that you are the MASTER during your performance. Your audience will think so and you must keep them thinking so.

I shall tell you of one experience I had with the so-called wiseacre. This man insisted on making noise during my performance. Instead of becoming provoked and arguing with him, I said to the audience: "It isn't very often in performing on occasions like this that I have a magician in the audience, so I am going to ask him to come up and help me."

Then I gave him a few articles and said: "I am going to let you do the next trick. You know this one is familiar to all of us magicians. I think it is about the first one we learn. It is called THE BURNING HANDKERCHIEF. Now you show the audience how we do this."

Then I sat down and waited for him to do the trick. Needless to say, he was unable to do it and appeared ridiculous in the eyes of the audience. That was the last I heard of him.

Another way of dealing with this sort of person is to describe hurriedly what you are going to do and give him the

material without the secret apparatus. Of course, he is stunned, and you can go on with your show.

A good scheme is to tie the double tapes around his neck, pass them through his sleeves and tie the rings on without using the fake joining. Give the two ends to two spectators to hold. Then tell this man that as he is an accomplished magician he will have no difficulty in escaping from the ropes while the gentlemen pull on them. Of course, he is unsuccessful. Then you arrange the tapes with fake joining principle and put them around another gentleman. You get your effect, and the wiseacre is squelched.

Every emergency requires its special method of handling. Be prepared to meet an emergency when it arises.

SEE OTHER MAGICIANS AT WORK--

Grasp every opportunity to see magicians at work. You can learn a great deal if you go to a performance with an open mind and look for things to learn. Watch the professional. Notice how he presents his program. Watch for these things:

- 1--How he enters.
- 2--How he leaves the stage.
- 3--His speed of working.
- 4--How he reaches a climax.
- 5--His use of misdirection.
- 6--His patter.
- 7--All his means of adding to his SHOWMANSHIP.

When attending a program given by a magician, do all you can to help him, for he has the same interests at heart which you have and naturally you want him to succeed. Encourage him in his work. Tell your friends that he is playing in town. Always speak well of your brother magicians and of the Art of Magic. Doing so adds to your own prestige as well as to the prestige of others. It is usually the case that when we do a good turn for another, the reward comes back to us.

If some magician comes to your town and you want to meet him, you can manage to introduce yourself to him. He will be glad to meet you as you have a great common interest. However, do not be too insistent. Remember that he is a busy man, and you must be considerate if you desire to win his regard. Do not just loiter around and waste his time. Use good judgment. You may invite him to your home, perhaps for luncheon or dinner. You may have a little effect which you can show him, and he in turn will, no doubt, reciprocate. In this way you establish a basis of friendship which may mean a great deal to you.

* * * * *

WRITE ME ABOUT YOUR SUCCESS WITH YOUR SHOW

I am deeply interested in the work you are doing. I want to know how you are progressing and what you are accomplish-

(10-10)

ing. I have received some very welcome letters from some students, but from others I have received no word at all. Now that you are going to give a performance, you will be able to write me all about it. It will mean a great deal to you to write me about your success and your difficulties as it will give me an idea as to how I can be of greatest service to you.

Remember that I am eagerly awaiting word from you as to how you came out on your show. To help you and to give me an understanding of what you are doing, I give you this little outline of what I should like to have you write me about. Do not hesitate to tell me other things which have occurred to you and to add any remarks you desire to.

1--Give me your program.

2--What was your reaction to your audience—that is, how did you feel when you faced them, both in the beginning of the performance and as you progressed with your show?

3--What was your audience's reception of you—what was their attitude in the beginning and what was it later on during the program?

4--Which tricks did they seem to like? Which caused comment during the performance and which did they talk about afterwards? What remarks did they make?

5--Did you have any difficulties? What where they?

6--Which effects were you particularly successful with?

7--Have you any new effects or new ways of working?

8--What do you think of the Course in Magic you are studying?

Do not hesitate to give me any suggestions or make any remarks on the course. I shall welcome anything you have to say.

LESSON 11

In this lesson I give you three interesting rubber band effects and an amazing thumb tie experiment. These effects are different and offer wonderful opportunities for showmanship.

1--Two rubber bands are wound finger by finger around right hand. A nickeled ring is placed on second finger and it is shown that the bands prevent ring from passing down to base of finger. Yet suddenly the ring seems to penetrate the bands and slides down the finger. The bands are shown to be still around all the fingers, and yet in another moment the ring slips off the finger.

2--A rubber band is placed over first and second fingers of right hand. Another band is wound around all the fingers. Suddenly the first band mysteriously jumps to third and fourth fingers. Then it jumps back again in a most puzzling manner.

3--Performer's two thumbs are bound with a heavy rubber band. In spite of this he passes hoops over onto one of his arms and passes his tied thumbs through a broom handle or cane.

4--Famous Japanese thumb tie. Performer has his two thumbs tied with two cords or wires. He then passes his thumbs through hoops, canes, rods, etc., and gets them out again between his thumbs while they are still securely bound.

Harlan Tarbell

TARBELL SYSTEM, INCORPORATED, Chicago.

(10-12)

LESSON 11

The size of a trick means very little in the Magical Profession. You may take any small, simple trick and make a masterpiece of it with Showmanship. The effects which you see on the stage appear to be very big effects, whereas in reality most of them are amazingly simple. So don't let yourself be carried away by the idea that you must have "big" tricks. Houdini makes of the simplest experiments the greatest effects. With his Showmanship he makes a trick with five packages of needles and a spool of thread become a wonderful stage effect.

The effects which I give you in this lesson are not difficult, but they are exceedingly mysterious. While they are really simple when presented, they give the impression that they are "big" effects.

The beauty of them is that they are entirely impromptu and can be presented at a moment's notice anywhere.

THE PENETRATING RING

EFFECT:

Magician takes two rubber bands and twists them around each finger of his right hand. An examined nicked ring is placed on the first joint of the second finger. Attention is called to the fact that it cannot slip down to the base of the finger because the rubber bands prevent it from doing so. In a moment, however, the ring passes the bands and slides down to the base of the finger. The rubber bands are still around all the fingers and the ring seems to have penetrated them. Then the magician slips the ring off his finger again, apparently right through the rubber bands.

PARAPHERNALIA:

1--Two rubber bands, about 2 3/4 inches long. Secure an ounce box of Eberhard Faber, size 18, rubber bands. I have always found these satisfactory. You can purchase them at almost any stationery store.

2--A nicked ring, about an inch in diameter. Ring must be large enough to slide on and off second finger of right hand easily. The nicked rings which I sent you with your apparatus are the kind I use.

3--A pair of scissors, preferably blunt end.

SECRET AND PATTERN:

To Perform:

Pick up two rubber bands and the nicked ring. "In this experiment I am using two rubber bands and a small nicked"

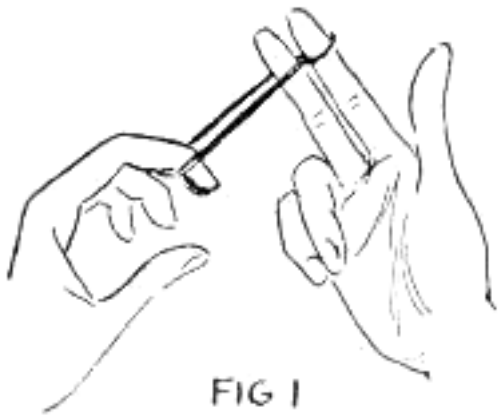


FIG. 1

ring. You can examine the ring, sir, as I place the bands around my fingers."

Give the ring to a spectator to examine. Place the two rubber bands together as one and wrap them around fingers of right hand as shown in Figures 1 and 2.



You can readily see how the bands wind in and out around the fingers. Keep bands between first and second joints of fingers. Show hand on both sides, spreading fingers so that audience can see that bands are wrapped around fingers fairly.

"You will note how the bands secure each finger by winding themselves around it and how they bind all the right fingers together. Now, if you will please give me the ring."



FIG. 2

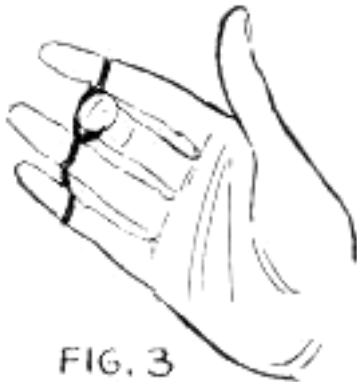


FIG. 3

Take ring from gentleman with left hand. As you do this, drop right hand at side for a second, and in doing so, slip SECOND finger from the rubber band loop around it. Figure 3.



FIG. 4

SECOND FINGER IN REAR OF BAND

When finger is free, place it in back of rubber bands. From the front of the hand it looks as though all the fingers are still tied, but in reality the second finger is free. You may even spread your fingers apart and it will look as though all the fingers are still wrapped with the rubber bands. Figure 4.

"I will place it on the first joint of my second finger."



FIG. 5

You must now show both sides of hand again to prove that bands are still secure. To show back of hand, push tip of second finger under the bands and let finger come in front of bands. You do this as you turn your hand. Then to show front of hand again, slip finger back to original position in back of bands.



FIG. 6

Practice this move until you can do it easily and naturally. To the audience it will appear that all the fingers are secured when you show them both sides of your hand again, whereas your second finger is really free. Study Figures 5 and 6.

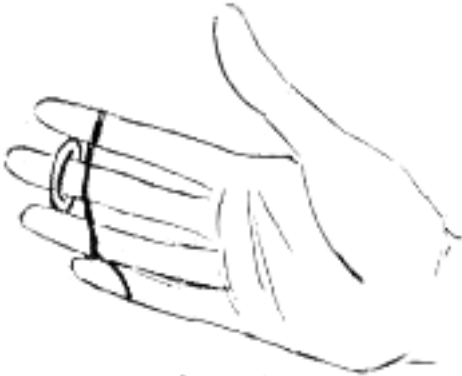


FIG. 7

Place ring on the first joint of the second finger of right hand outside the bands. You should stand turned a little toward the right with right hand held out to side about shoulder height. Figure 7.

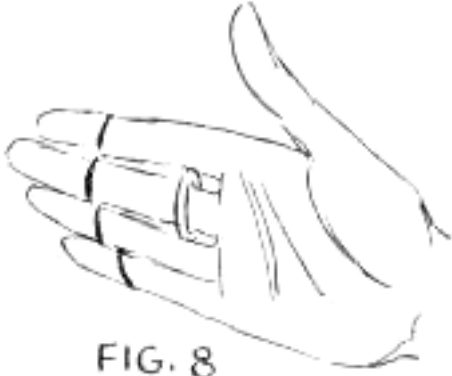
"It is said that a solid object cannot be passed through another solid object without harming either. That may

(11-2)

be true but this little ring is an exception to the rule. It is always running around and going into places you would least expect. Here it rests on my finger on the outside of these rubber bands. It cannot get down onto the base of my finger because these bands will not let it."

Spread fingers and show with the aid of left hand that ring cannot get beyond rubber bands. Close fingers together again.

"That's what we say, but the ring says not so."



Push hand out suddenly and allow ring to slip down past bands onto the base of finger. This is easy to do as finger is free and need be lifted only slightly away from bands in order to permit the ring to slide down. Figure 8.

"See, here it is at the base of my finger. It has broken right through the traces. Iron bars do not a prison make—neither do rubber bands."



Show both sides of hand again. Keep fingers pointed upward a little and as you turn hand, slide second finger under bands as you did before. Figure 9.



The object of keeping your fingers pointed upward is to guard against dropping the ring off from the finger. As you turn hand to show back of it, there is danger of the ring slipping off unless you hold hand properly, as shown in Figure 10.



Now point fingers downward, palm of hand toward audience, and allow ring to slide off finger into left hand. Figure 11. Do this move quickly.

"Now—one, two, three—and the prisoner has escaped. I shall explain this again with a pair of scissors so that you will misunderstand it still further."



Take a pair of blunt-end scissors from pocket with left hand. Pass tip of second finger of right hand through one of the handles of scissors. Hold ends of scissors with left hand. Figure 12.

"I slip the first joint of my finger through a handle of the scissors."

Push scissors suddenly behind rubber bands to base of finger.

FIG. 12

"Well--well--here it is on the third joint."

Turn hand over and manipulate second finger to front of bands so that when back of hand is shown rubber bands seem to be around all the fingers.

(11-3)

Let go of scissors with left hand while hand is being turned.

Then show palm of hand again with second finger behind bands.

"But what's a joint or two between friends in prohibition time."

Pull scissors off of finger and away from hand.

"Now it is away from all joints."

Show right hand again, both sides, to convince audience that fingers are securely wrapped with the rubber bands.

"Rather an odd thing, that."

Pull bands from fingers suddenly to destroy the evidence.

* * * * *

THE JUMPING RUBBER BAND

I remember seeing this effect performed years ago by Theo. Bamberg (Okito). In the hands of this master of sleight of hand the illusion was a perfect thing.

This experiment is a good one to use before or after the PENETRATING RING effect. If you use this trick first, you can explain (?) how you did it with the ring. The audience, of course, is none the wiser after you finish than they were before.

EFFECT:

A rubber band is placed over first and second fingers of right hand. Another band is twisted around fingers, one at a time, between first and second joints. The first band seems to be secured on fingers by the second band, but in a moment the first band suddenly jumps down around the third and fourth fingers. Then it jumps back again around first and second fingers.

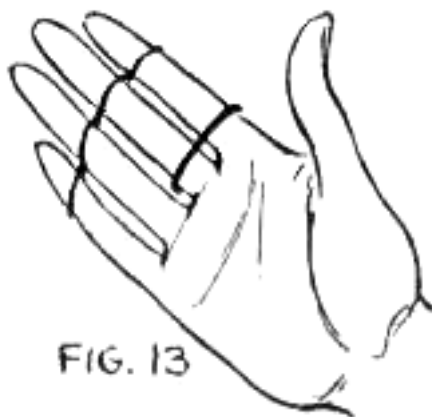
PARAPHERNALIA:

1--Two rubber bands (as described in preceding effect).

SECRET AND PATTERN:

To Perform:

Take one of the rubber bands, double it, and place it around the first and second fingers of your right hand. Figure 13.



(11-4)

"Yesterday afternoon when I was in China I saw a very funny effect with a rubber band. A Chinaman took a rubber band and placed it around his fingers just as I have done here."

Show right hand, both sides.

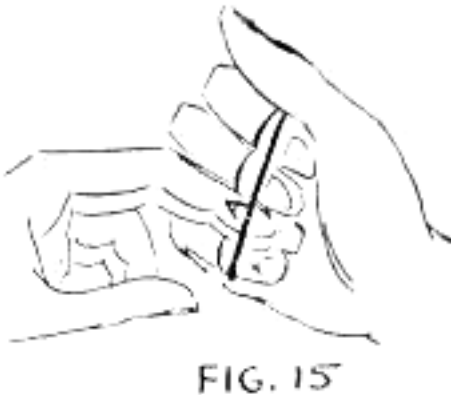
"Then he took another band and wrapped it around all his fingers so that the other rubber band could not get away."

Twist a second band around all fingers of right hand between first and second joints, as you did in THE PENETRATING RING effect. Show both sides of hand.

"Quite a clever Chinaman."



Hold right hand in front of you, back of it to audience. Slip index and second fingers of left hand under band A and pull out about an inch or two from right hand. Figure 14. This is screened by hand.

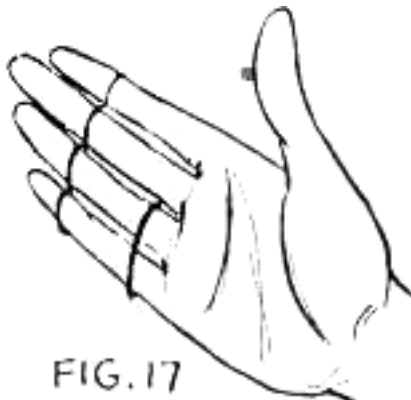


Then close right hand and as you do so push all four fingers of right hand through band A. This brings band A into this position: It is around first and second fingers of right hand below the other rubber band. There is a twist in the band coming up between your second and third fingers. Then the band is around your third and fourth fingers above the other rubber band. Figure 15. Remove left hand.



Back of your hand is toward audience, and your hand is closed for only a second so that audience cannot see the move you make here. You are working from the inside of your palm so that audience sees the rubber bands still in position on the back of your hand. Figure 16.

"Then he closed his hand and said, 'Hi-Diddle-Diddle,' and would you believe it . . . "



Open hand suddenly, stretching out first the first and second fingers. The rubber band jumps down onto the third and fourth fingers below the first band.

Open hand wide and show it on both sides. Figure 17.

"The rubber band jumped down onto the two other fingers."



FIG. 18

With back of hand to audience again, slip thumb of right hand under band A. Pull band away from hand. Figure 18.



FIG. 19

Close fingers again so that all four fingers go through loop. Figure 19.

(11-5)

Then remove thumb and let band A rest on finger tips.

"Then he closed his hand again and said, 'Eenie-Meenie-Miney-Mo . . . '."

Open hand far enough to permit band to jump back to first and second fingers.

"And up jumped the rubber band again to the top of two fingers. Now, for the benefit of those who do not understand this, I will explain it—in Chinese."

Repeat first move of pulling band away from hand with two fingers of left hand. Close right hand, get fingers into loop, and remove left fingers.

"All he had to do when the band was on the top fingers was to say, 'Parlay voo Fransay?' ..."

Let band fly to lower two fingers.

"And down she goes. Then he would say, 'Sprechen Sie Deutsch?' ..."

Place thumb under band A, as explained previously. Lift band away from hand, close hand, place fingers in loop, remove thumb. Open fingers slightly and band flies to upper two fingers again.

"And up goes the band again."

Show hands, both sides.

"Rather a foolish explanation, but good."

Remove bands from hand.

* * * * *

THUMB TIE WITH RUBBER BAND

EFFECT:

Performer's two thumbs are securely bound with a heavy rubber band. Yet in spite of this, he passes hoops onto his arms and passes his tied thumbs through a broom handle or cane.

PARAPHERNALIA:

1--A large, heavy rubber band. Experimentation will show you the size best adapted to your thumbs. Band must not be too tight or too loose.

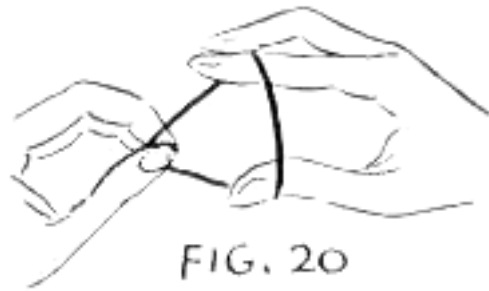
2--A broom or cane.

3--Two or three large metal rings or wooden hoops, such as those used for doing embroidery work.

To Perform:

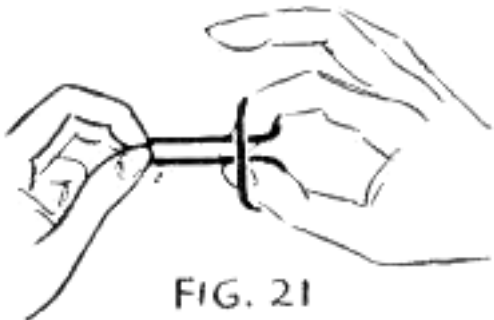
Request someone to come up from audience to assist you. Have assistant stand at your right.

"A rubber band is only a small article, but it can hang on about as well as anything I know. It is said that once a Japanese policeman, not having a rope handy, tied up his prisoner with rubber bands. And the prisoner didn't get loose either because the policeman knew how to tie him. One of the bands, I have been told, went around the thumbs."

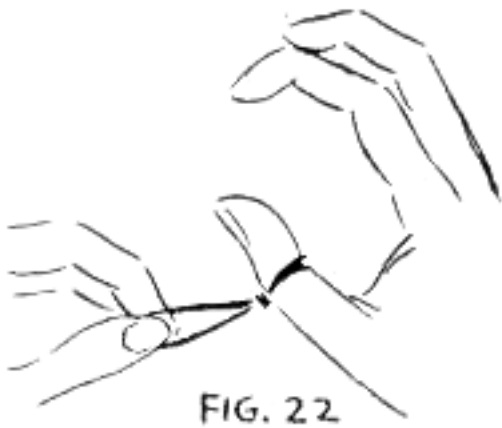


Follow these moves carefully. They are not difficult, but you must watch the details to get them correct.

Hold band in left hand. Push thumb and index finger of right hand through band. Figure 20.

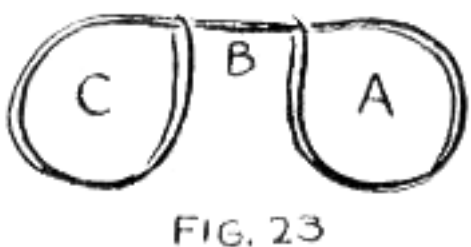


Make loops in band with thumb and first finger, as shown in Figure 21.



Slip loop from index finger over onto thumb. This leaves your thumb secured by a double loop in the rubber band. Figure 22.

Repeat this series of moves exactly in the same way with the left thumb.



You now have the arrangement pictured in Figure 23. Loop around right thumb is A, loop around left thumb is C, and the band between loops is B.



"Something like this. Anyway, I am well tied. A nice time I would have getting my thumbs out of two tight loops like these."

Show hands, both sides, and move thumbs to show that they are tightly bound. Figure 24.

Pick up cane or broom and give it to assistant from audience.

"Now, if you will please hold this broom up. . . . That's right, the brush part on the floor and the handle up. Now please hold the upper end tight."

Have spectator assisting you hold broom straight up in a vertical position.

"Nothing could pass under the broom because of the floor or above the broom because of the gentleman's hands."



FIG. 25

As you say this, screen right hand with left and push second finger of right hand into Loop C. Then insert third finger also in Loop C. Figure 25.



FIG. 26

When loop is secure on second and third fingers of right hand, remove left thumb from Loop C. Be careful to screen this movement behind hands. Figure 26.



FIG. 27

Place left thumb quickly under B portion of rubber band. Keep hands close together so that assistant and audience cannot see your movements. Figure 27.



FIG. 28

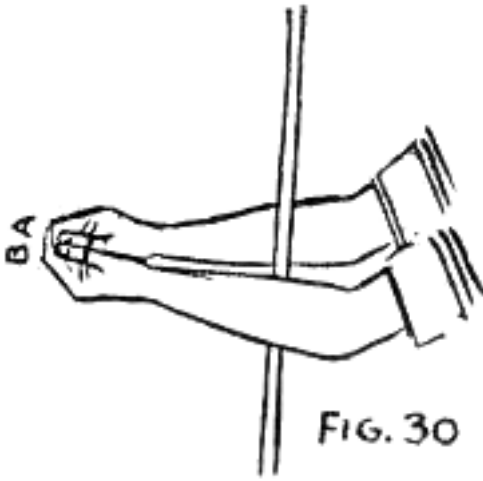
Pull down slightly with fingers in Loop C and bring two thumbs close together. The audience is not aware that you have made any change in the arrangement of the rubber band. It appears that the thumbs are still secure in the loops. Figure 28.

"Oh, I forgot to tell you. The policeman placed the man's arms around a small tree for extra precaution."



FIG. 29

As you say this, bring hands up to broom about a third of its length from the top. Withdraw left thumb from under band. Open hands only enough to allow broom handle to pass between. Figure 29.



When hands are around broom handle, like a flash slip left thumb under B portion of rubber band again. Turn thumbs to audience and to assistant to show that they are still securely bound. Figure 30. The effect produced is that you have passed broom handle right through rubber band between your hands.

"Like this. Now my arms are around the tree, or broom rather. Of course, being bound like this, it is impossible ..."

Slip thumb out of B, bring hands away from broom handle, and slip thumb back under B again very quickly.

Practice for perfection in this move. You must perform it very rapidly so that neither assistant nor audience suspect you are doing anything out of the ordinary. Be

careful to keep hands screened and hold them as closely together as possible while passing them around broom handle.

"To escape."

"Now that you understand that, I shall explain it again."

Repeat above effect – putting arms around broom handle and then bringing arms away.

"Please, lay the broom aside and we will use these rings."

Pick up rings from table and give them to spectator assisting you, all the while keeping thumbs closely together.

"Examine these rings to see they are perfectly solid. You are satisfied? Toss one to me so that I can catch it when I have counted three. Are you ready? One - two - three."

As ring is thrown, draw away thumb and open up hands slightly to catch ring on right arm. Place left thumb back in place quickly, then show that hands are still tied.

"I didn't mean that you should throw it quite so hard. You see you threw it on my arm. But I'll forgive you this time. Now throw another ring."

Catch the second ring as you did the first one. Then show that thumbs are still tied.

"I guess the second ring wanted to be with his brother. Toss the third one. One - two - three."

Catch the third ring, allowing it to pass onto left arm.

"This one is more exclusive. See, it went onto my left arm. Will you please take them off?"

Spectator tries to take them off, but, of course, he is unable to do so.

"So, they will not come off. Well, no wonder, you didn't speak to the rings according to the manner set forth in the latest book on etiquette. You should say, 'If it will not inconvenience your royal highnesses, I should like to have your presence at my home for afternoon tea,' . . ."

Slide rings all over onto left wrist. Then removing thumb from loop quickly, let rings slide onto the tips of your fingers. Slip thumb back into loop immediately.

"And away they go."

Give three rings to assistant.

Show thumbs still tied securely.

Now open Loop C a little with second and third fingers of left hand and quickly slip it back onto left thumb. Remove

other fingers. Loops are around both thumbs again as they were in the beginning of the effect. You may now have assistant examine bands around thumbs and remove them to see that they are intact.

"The moral of which is, 'It is better to be a magician than to go to jail'."

* * * * *

THE JAPANESE THUMB TIE

I first saw this thumb tie performed by Asahi, the Japanese magician, a number of years ago. His presentation of it made it a work of art. His co-ordination of movements was so perfect that he could produce his effect right in the midst of the audience as well as on the stage. Ten Ichi, another Japanese performer, produced this same effect also.

The experiment created a sensation among magicians, and many solutions to the secret have been brought forth, some good, some mediocre. The method which I describe here is the most practical method and the one which is favored by the Japanese magicians. The Japanese magicians, however, use twine or rope bound with rice paper, where as I have found pipe cleaners to be very satisfactory and need no preparation. Instead of tying the thumbs with ropes, I use the wiring method. This is just as effective as tying.

First, I shall describe the pipe cleaner method and then I shall teach you how to prepare ropes with rice paper to be used in the original Japanese tying method.

EFFECT:

Performer has his two thumbs securely tied together with two cords. He rapidly passes solid hoops onto his arms and removes them, showing his thumbs to be tied all the while. He also passes his thumbs through canes, rods, a person's arm, etc., in a most mysterious manner.

PARAPHERNALIA:

1--A package of pipe cleaners. These can be purchased at any cigar store.

2--Three rings. Wooden hoops, such as women use in doing fancy work, are suitable. Use a large size hoop. Large nicked rings, about 6 to 8 inches in diameter, such as magicians use in the linking ring trick, are especially adapted to this effect. The rings must be large enough to slip over the hands onto your arms readily.

3--A wooden pole about 5 feet long, or a piece of bamboo fishing pole the same length, or a cane, or broom.

SECRET AND PATTERN:

To Prepare:

Take three pipe cleaners and twist them around each other to make a twisted cord, fairly large in diameter. Prepare another cord in the same manner, using three more pipe cleaners. Figure 31.

To Perform:

Request a spectator to come up from audience to assist you.

"Many people give much credit to the supernatural, and it seems that in Magic much of the work is supernatural. However, it only appears to be supernatural. In reality it depends on natural laws. We may not understand the law at work, but it is functioning nevertheless. A hundred years ago if you were to have exhibited a radio and picked up messages from the air, you would have been considered supernatural and the messages would have been regarded as spirit voices. It seems incredible that waves can pass through solid objects, yet they do. An X-ray machine, for instance, sends its rays through the human body and makes objects visible through the solid body. Many years ago a famous Japanese magician discovered this law of the penetration of solid objects and demonstrated it to his audiences in a peculiar manner. With the assistance of this gentleman here I am going to show you how the Japanese worked."

Pick up the two prepared cords of pipe cleaners.

"These are wire cords covered with a cloth material so that they will not cut into the skin of my hands. Will you, sir, hold them a moment and examine them to make sure that they are merely wires wrapped together?"

Hand spectator one of the cords.

"Take one of the cords, sir, and wrap or bind my two thumbs together securely. Wire them together as tightly as you choose, without hurting me too much, of course."

Show hands, both sides, fingers spread wide apart.

Cross your thumbs - the left one over the right.
Figure. 32.

"I'll place my thumbs on the cord."



FIG. 31



FIG. 32



FIG.
33

Have spectator hold cord so that you can place thumbs on it as shown in Figure 33.

"Now, bring the ends together at the top and wire them together tightly."

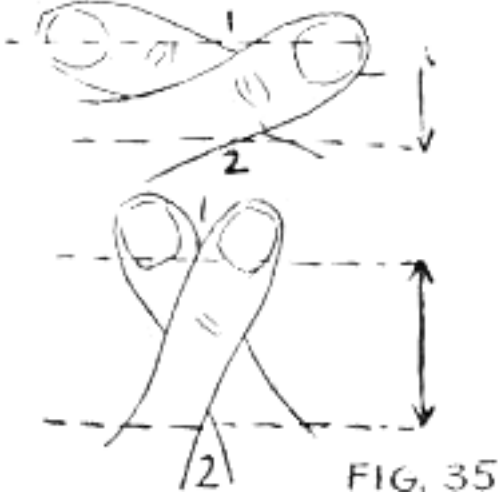
(11-11)

Spectator twists ends of cord together, thus tying the two thumbs securely together. Figure 34.



IMPORTANT:

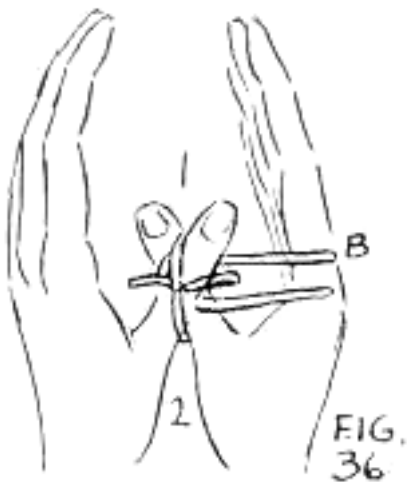
While spectator is wiring your thumbs you have an important move to make, unknown to him. You must get slack in the cord though to all appearances your thumbs are bound tight together.



By moving your thumbs backward and forward with your joints acting as a pivot, you can vary the distance between points 1 and 2. The nearer the base of your thumbs come together, the greater is the distance across your thumbs from 1 to 2. It requires more cord or wire to encircle your two thumbs when bases of thumbs are near each other than when they are farther apart. Figure 35.

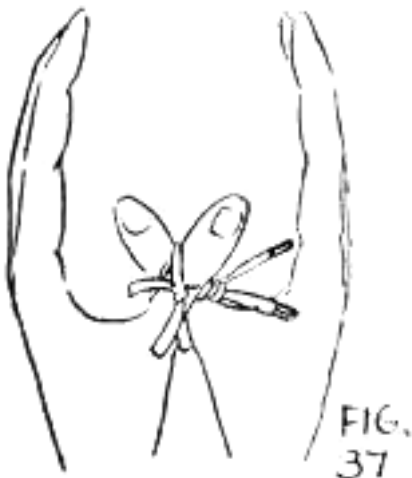
Hold your thumbs so that you have plenty of cord around your thumbs when they are bound together. If you were now to move bases of thumbs apart, you would find that you could easily slip right thumb out of the wire loop.

"There is no doubt but that you have the power of wiring tight. Were you a sailor? Now pass the other cord between my thumbs to make doubly sure that they are well tied."



Have spectator place second cord between thumbs, looping it around to the left and bringing the ends out to the right as shown by Figure 36.

"Wire this second cord together and tight against my thumbs."



HOLD YOUR THUMBS TIGHT TOGETHER so that it is impossible to get wire twisted between thumbs. In this way you save the extra amount of cord which you have around thumbs.

Spectator twists cord, apparently tight between thumbs. Figure 37.

"Now wire all four ends together at the top."



FIG. 38

Assistant twists the four ends of the two cords securely on top of thumbs. Figure 38.

Show thumbs and palms of hands to audience. Turn hands downward and show backs of hands also.

"You are satisfied, are you not, that my thumbs have been securely tied together or rather wired together? You notice that the cords are below the large joints of my thumbs and consequently there is no way that I could release my thumbs."

Ask assistant to take pole and hold it in a vertical position, one end on the floor and the other in his hands.

"Now will you please hold up the pole. Place one end on the floor and hold tightly to the other end with both hands."

(11-12)



FIG. 39

Assistant should be standing at right and a little in front of you. Have him hold pole a little to his left and far enough in front of him so that audience gets a good view of it. Figure 39.

Show hands and thumbs again. Then face assistant.

Your left side and back of left hand is toward audience.

TO TEST THE TIES:

Keep your hands together to screen movements from assistant and from audience.

I want you to test the ties to be sure that you can slip your right thumb out of loop quickly and back in again easily.



FIG. 40

Pull down on Cord A by trying to pull right thumb away from left thumb. With fingers of left hand work up Cord B (the one between the thumbs) tight against left thumb. Place second and third fingers of left hand on loop around right thumb and withdraw thumb. Figure 40.

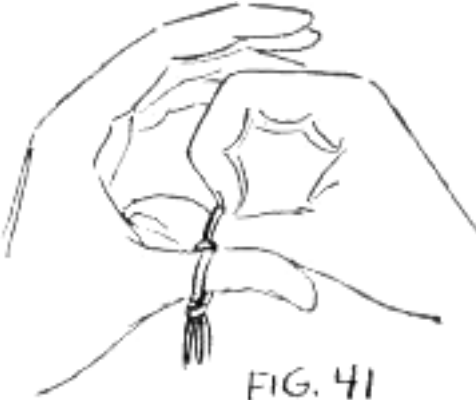


FIG. 41

You may aid in getting thumb out of loop by pushing on loop with tips of fingers of right hand. Figure 41.

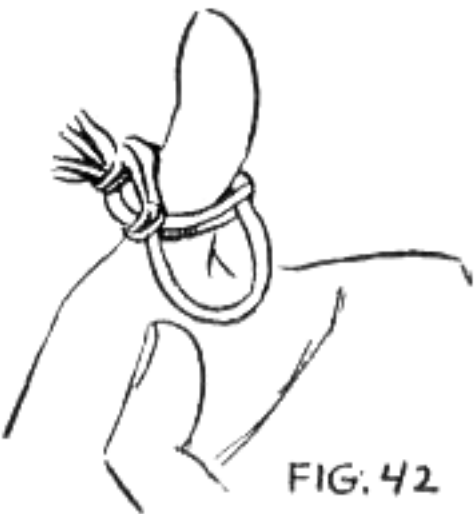
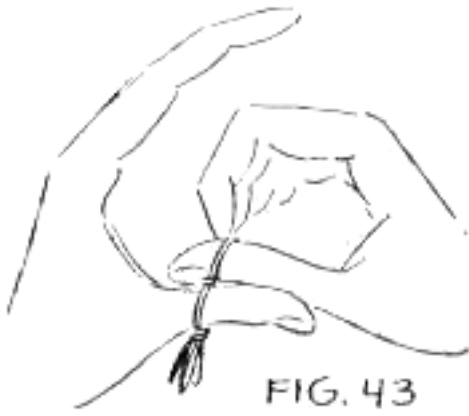


FIG. 42

When your right thumb is free, you find that you have a loop of the wires around left thumb and a free loop which you use in inserting and withdrawing right thumb. Figure 42.



As soon as you have freed your thumb, slip it back into the loop again quickly. Use the tips of fingers of your right hand to help you. Figure. 43.

Then quickly open your hands out flat.

"Will you explain to me, sir, why it is that when my hands are on this side of the pole my arms are away from the pole, but ..."

Put hands up against pole so that your thumbs touch it, then draw hands back toward chest with your finger tips together. Now slip right thumb out of loop.

Suddenly push hands forward again, spreading them just enough to permit them to pass around pole.

(11-13)

The instant thumbs are past pole, insert right thumb into loop again very quickly. Turn backs of hands to audience to show them that thumbs are still tied.



"When my hands are on the other side, my arms are around the pole?"

Swing arms and hands around so that audience and spectator can readily see that arms are really around the pole and that THUMBS ARE STILL TIED. Figure 44.

Then suddenly pull your hands back, release right thumb, allowing pole to pass back through hands. Quickly insert thumb back into loop, and show thumbs still tied and pole freed from arms.

"Now the pole is free again, or I am. It is just like this. We are here."

Push hands through pole again and show tied thumbs and arms around pole.

"And here we are there."

Bring arms back to original position, freeing pole.

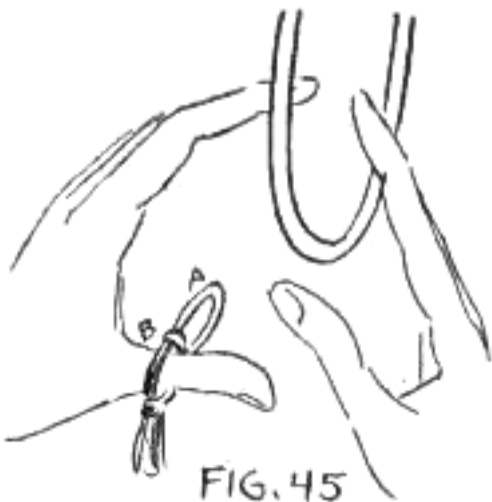
Hold thumbs up close to assistant to examine.

This illusion is perfect when properly performed. It really appears that pole passes through tied thumbs or solid hands or arms.

"Just set the pole down a moment and take these three rings."

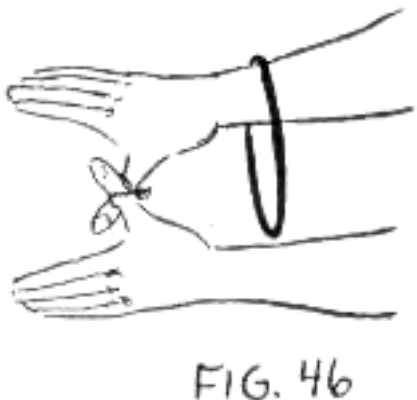
Spectator puts down the pole and takes the three rings.

"These rings are made around a circle and I am sure that you will find no ends to them nor any secret openings. There are none. Some people think the rings come apart in some mysterious manner or that there are trap doors in them. Now just toss me a ring."



Stand several feet away from spectator, facing him. He is at your right, therefore audience is to your left when you face him.

Catch first ring in fingers of both hands. Figure 45.



"Not quite right that time. Throw it again."

As spectator throws ring again, release right thumb from loop, spread hands apart a little and allow ring to pass over onto right arm. Figure 46.

As soon as ring has passed thumbs, insert right thumb back into loop.

"Now, see what you have done -- you have thrown the ring right onto my arm."

Show thumbs tied and ring on arm.

"Will you please take it off?"

Assistant is, of course, unable to remove ring because of tied thumbs.

"Oh, well, never mind. Just toss me another ring."

Assistant tosses another ring. Catch this on your arm as you did the first one.

"I knew you threw that one too quickly. See, here it is on my arm also."

Again show thumbs and arms.

"All ready for the last one."

Assistant throws third ring. Catch this one on left arm.

"This ring is left -- that happened because you didn't throw it right. Here I have three rings on my arms, -- bracelets, as it were. But what am I to do with them?"

Drop hands downward so that rings slide down to bases of thumbs and hang down over hands.

"Ah - ha, I have an idea."

Suddenly release right thumb and let rings slide down to tips of fingers outside of thumbs. Insert right thumb immediately in loop again.

Perform this move very smoothly so that assistant and audience will not even notice it and think that rings are still on arms.

"I'll give them to my friend here to wear."

Toss rings to assistant.

Show thumbs tied.

"You don't want them? Then we'll lay them aside."

Put rings on table.

"Now, place your right hand on my right shoulder."

Assistant does this. Your arms are below his arm. Figure 47.

Quickly bring your hands upward and pass them through his arm, releasing thumb. As soon as your hands are above his arm, insert thumb in loop again. Show thumbs tied.

"You see I meant to have your arm under mine, instead of . . ."

Bring hands down quickly through arm again.

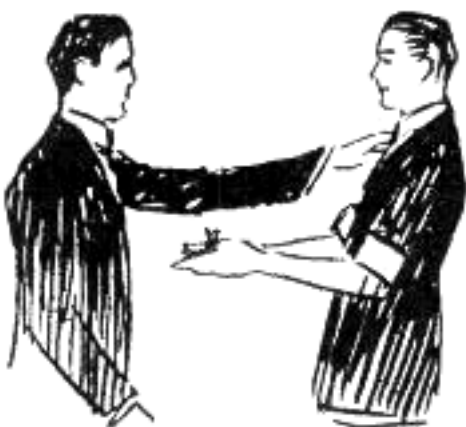


FIG. 47

"Over mine, as it is now."

Show thumbs again, securely tied.

"Please untie my thumbs and notice as you do so that they are secure just as you wired them."

Assistant untwists wires and removes cords.

"There are the marks on my thumbs from the tight wires."

Show marks on thumbs caused by binding.

"But that always goes with the experiment. I thank you."

Assistant returns to his seat.

NOTE:

The Thumb Tie Principle offers great opportunity for variety in performance. Thumbs can be passed through backs of chairs, through performer's leg, and a variety of objects can be slid onto performer's arms. Try to work out some original angle for the use of this principle. You will find it fascinating.

Devote much time TO PRACTISE OF WITHDRAWING AND INSERTING RIGHT THUMB IN LOOP. Get it down so well that there is but an instant between release of thumb and retying. Ten Ichi and Asahi work it like a flash. Practice this move at home. Have someone tie you several times and then go into another room and repeatedly practice withdrawing and inserting right thumb in loop. DO NOT EXPOSE THE MOVE to the one who is tying you.

TO MAKE JAPANESE CORDS FOR TYING:

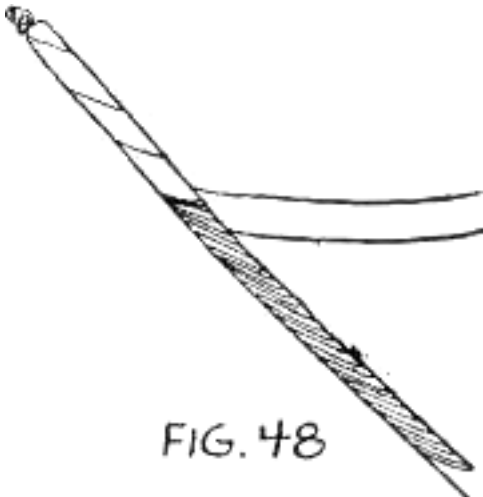
Get some cord about one-eighth to three-sixteenths of an inch in diameter and about eleven inches long.

Take a strip of heavy parchment or gloss tissue paper or genuine rice paper, if you can secure any about an inch wide. Cut this material into inch strips.

Roll the paper around the cord diagonally, overlapping each turn a little to cover the cord completely. Twist the ends of paper to hold it on cord securely. Figure 48.

Prepare another cord in the same way. To make the working of the principle easy, the cords must be fairly stiff. That's why pipe cleaners work so satisfactorily. Wrapping paper around cord makes them fairly stiff and suitable for performing the move.

FIG. 48



This thumb tie which I have given you is one of the best methods known and is especially good because of its impromptu nature. Perfect yourself in performing it.

Later on in the course under Japanese Magic I will teach you another Japanese Thumb Tie in which the thumbs are tied separately and rings are passed onto the arms without slipping the thumbs from their ties.

A handwritten signature in cursive script that reads "Harlan Tarbell". The signature is fluid and elegant, with a large, sweeping flourish at the end.

TARBELL SYSTEM, INCORPORATED, Chicago.

* * * * *

LESSON 12

In your next lesson I am going to teach you three great classics in Card Magic:

1--Twelve cards are counted into each of performer's hands. Twelve of these are wrapped in a handkerchief and given to spectator to hold. The other twelve are given to another spectator. Someone in audience selects a small number. Performer causes the exact number of cards chosen to fly mysteriously from the twelve held by one spectator to the twelve wrapped in the handkerchief and held by the other spectator.

2--Twelve cards are counted out and placed in magician's left hand. Performer shows right trousers' pocket to be empty. Then he causes cards from left hand to travel invisibly into right trousers' pocket one at a time. Spectator is asked to reach into pocket and remove card from time to time.

3--A number of cards are counted into magician's left hand. One by one he causes them to pass up his left sleeve and produces them from his shoulder.

(11-17)

LESSON 12

This is a very important lesson for in it I give you three of the greatest card classics known to Magic.

Be sure to review Lesson 9 before beginning the study of this lesson. In that lesson I set forth for you some marvellous principles on which Card Magic is based. I hope that you mastered these principles as you will need a thorough knowledge of them to perform these effects.

In addition, I give you the following new card principles:

- 1 -- The Card Transfer
- 2 -- The False Count
- 3 -- Misdirection Palming
- 4 -- Pocket Concealment
- 5 -- Self-Contained Card Vanish
- 6 -- Back to Front Hand Card Vanish
- 7 -- Pivot Card Vanish

The mechanical arrangements are:

- 1 -- The Sleeve Pocket
- 2 -- Shoulder Concealment

CARDS THAT PASS IN THE NIGHT

This is my version of the famous "Thirty Card Trick" or "The Cards from Pocket to Pocket," which has been so popular with conjurers. Every magician of note has his own angles of working this effect and various sleights which he uses in accomplishing it. I have used many ways in presenting this experiment, but the one that I am going to teach you is my favorite method.

This effect is one of those magical experiments which seem to be performed supernaturally. It permits of fine Showmanship and enables you to impress upon your audience the fact that you are doing Master Magic.

EFFECT:

Twelve cards are counted into the performer's left hand by a spectator and twelve cards are counted into his right hand also. Spectator then wraps the right-hand packet of cards in a handkerchief and holds it during performance of effect. The left-hand packet is given to another spectator to hold. Someone in audience is requested to call a number between one and five. Let us assume that number three is called. Performer now says he will cause three cards to pass

from the spectator holding the twelve cards to the spectator holding the packet wrapped in the handkerchief. One card passes. Another card passes. Performer counts packet of cards and finds there are only ten. Magician now pretends to take a third card from packet and to hold its "spirit" in his hand. Spectator then counts the cards and finds there are only nine. Magician now pretends to put the "spirit" card back and then the packet is found to contain ten cards again. The invisible card is removed again and the packet contains nine cards. Performer tosses invisible card to packet in handkerchief. Three cards have now passed. Spectator takes packet from handkerchief and counts cards. He finds that he now holds fifteen cards instead of twelve.

PARAPHERNALIA:

1--A deck of cards.

2--A borrowed handkerchief.

SECRET AND PATTERN:

To Perform:*

Take deck of cards from pocket or borrow a deck and remove cards from case.

Have two gentlemen come up from audience. You stand between the two men. Turn to the one on the left and say,

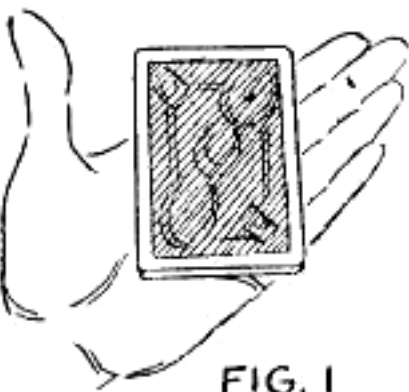
"Will you, sir, kindly help me with this experiment? I want you to shuffle this deck thoroughly and count twelve cards into my left hand."

NOTE:

As a rule, performers count fifteen cards into each hand or onto the table. The two pockets contain thirty cards. This is where the trick gets the name "Thirty Card Trick." However, I prefer to use twelve cards in each packet for several reasons. You will understand this when you master the effect.

Give cards to spectator to shuffle.

"Count TWELVE cards into my left hand one at a time and count them loud enough so that all may hear you."



Performer holds out left hand, palm upward, and spectator counts twelve cards out one at a time into his palm. Fig. 1. The cards should be counted backs up. If spectator does not count loud enough, you count with him. You must impress upon your audience the fact that twelve cards are in your hand.

"TWELVE cards."



FIG. 2

Hold up packet of twelve cards and fan it out slightly. Fig. 2.

"You are correct, sir - a very good mathematician."



FIG. 3

Square up cards again. As you do so, insert first joint of little finger of left hand under top three cards in packet. Your left hand and little finger are in the same position as they were in doing the simplified pass explained in Lesson 9. Fig. 3.

Drop left hand with packet at your side. Hold cards so that audience is not aware of position of little finger, separating top three cards.

To the audience it appears that all you have done is to fan open cards to be sure that spectator was right in his count.

"Now, count TWELVE cards onto the palm of my right hand. Count them one at a time aloud so that there will be no mistake in the number."



FIG. 4

Spectator counts twelve cards out onto performer's right hand as he did onto the left hand.

Now square up cards and reverse them so that they face upwards. Hold them between tips of fingers and thumb. Fig. 4.



FIG. 5

Hold hands far apart - packet in right hand with faces of cards up; packet in left hand with little finger separating top three cards. Fig. 5.

"Twelve cards in my right hand also. Thank you."





FIG. 6



Turn slightly to left toward spectator there. As you do so, take position shown in Figure 6.

Turn your right hand back to audience and bring packet of cards in each hand on a horizontal line with each other.

Say to gentleman on left:

"Have you a handkerchief which we can use?"

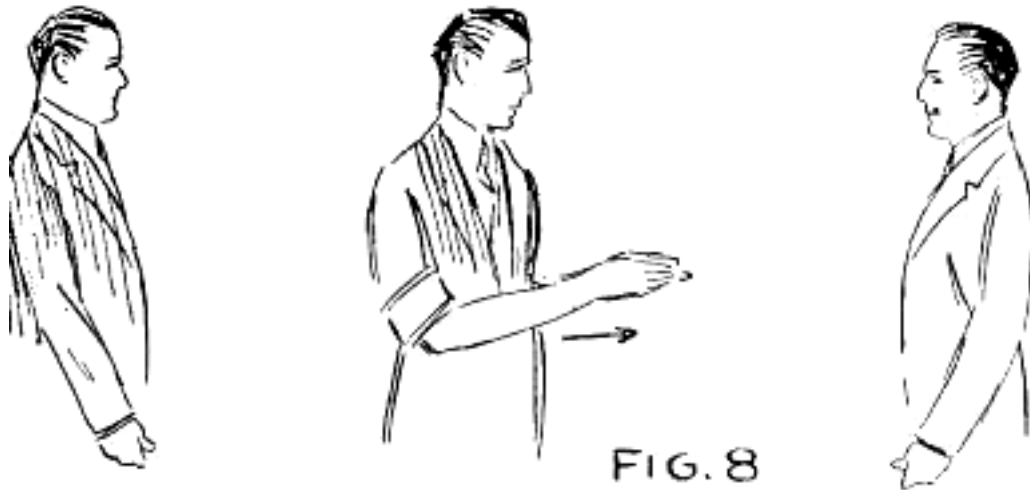
THE CARD TRANSFER:

The following move teaches you the principle of transferring cards from one packet to another. Study it carefully and practice it until you can perform it perfectly.

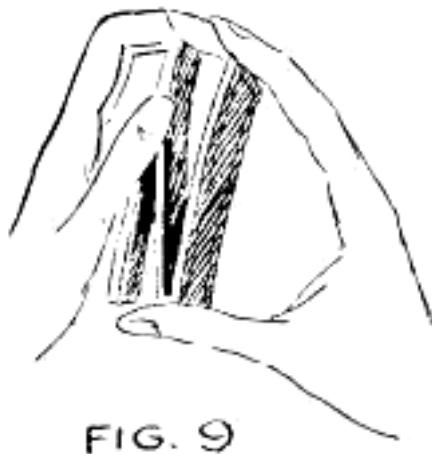
(12-3)



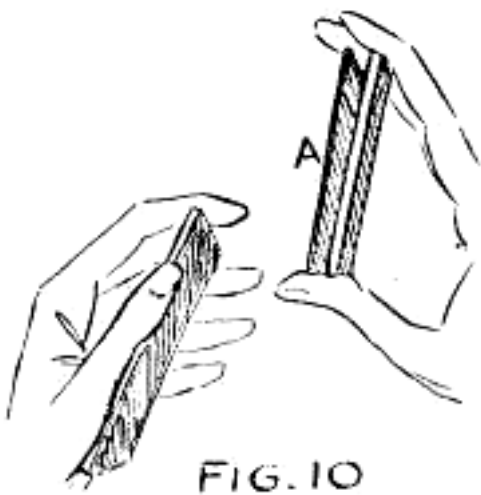
Your hands are in this position. Fig. 7. A designates the top three cards on the left hand packet.



As you ask for handkerchief, quickly pass packet in right hand over packet in left hand. Fig. 8.



Place your right thumb against the A section (top three cards) of packet in left hand. Your little finger separates these three cards from rest of packet so that it will not be difficult to grasp them with thumb of right hand. The first joints of second and third fingers of right hand bear down on the front end of the three cards. Fig. 9.



Carry these three cards away at bottom of packet in right hand. Bring them up against the rest of packet. Fig. 10.



This whole move is done very quickly. It must appear that you merely passed the right hand past the left as a gesture in asking for the handkerchief. You must not hesitate an instant in bringing away the three cards from left packet. Finish leaves right hand up in front of spectator for a moment. Fig. 11.

You now have NINE CARDS in LEFT PACKET and FIFTEEN CARDS in RIGHT PACKET.

"Thank you, that one will do nicely. I will have you wrap the TWELVE cards I hold here in the handkerchief. Wrap them securely so that no cards can get in or out without your knowing it."



Spectator wraps packet of fifteen cards in handkerchief. Fig. 12.

Of course, audience and spectator think that packet contains twelve cards.

(12-4)

"Hold them in your right hand, up about shoulder height, so that the audience can see them. Now, to make sure that the gentleman placed TWELVE cards in my left hand, I will count them again."

Your next move is to prove that the NINE cards which you hold are TWELVE.

THE FALSE COUNT:

Hold the nine cards faces toward you in your left hand, thumb on top of cards. Fig. 13.

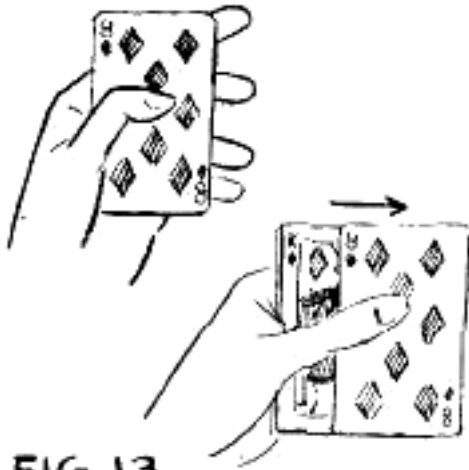
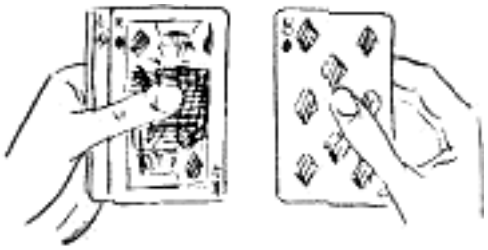


FIG. 13



Push first card over to right with thumb, grasp it with right hand and remove from packet. As you do this, count aloud. Fig. 14.

FIG. 14

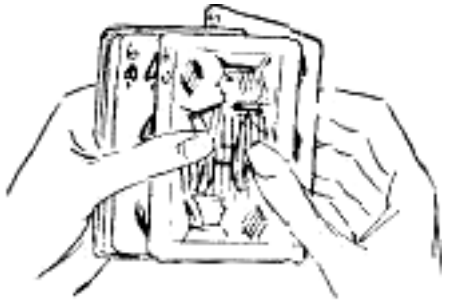


FIG. 15

"One."

Now push second card over to right a little with thumb. Bring card in right hand up behind packet in left hand and place right thumb on top of second card. Fig. 15.

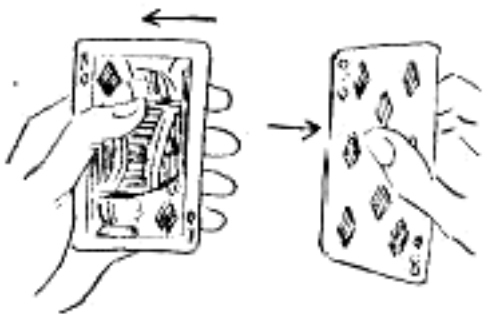


FIG. 16

You apparently take this card, but in reality you perform the FALSE COUNT. Move your right thumb toward right to make the sound of drawing the card from the pack. The second card extends over the edge of the pack for about an inch. By bending card at the edge with right thumb and then releasing it you get the snapping sound of removing a card from the pack. As your right thumb snaps the card, your left thumb draws the second card back onto the pack. Your right hand moves to the right several inches with the one card in it just as it would if you had really taken off another card from pack. Fig. 16.

"Two."

The audience has heard the drawing of the card and the snap, and naturally they think that you have pulled TWO cards from the packet and now have them in your right hand. You count -"two"- to help the illusion.

Stand in front of your mirror and practice this method of False Counting. The best thing to do is to actually count the cards and pass them from left hand to right. Then imitate the natural moves and hold back a card now and then.

False Counting is a very important principle in Magic. It sometimes proves to be a regular life-saver in an emergency.

You must be able to perform the move so well that the keenest eye cannot tell whether you did a straight or a

false count.

(12-5)

Count the third card actually into right hand on top of the one card there, making the snapping sound as you bring the card away from the packet.

"Three."

False count the next card, making the snapping sound.

"Four."

Count next card fairly, bringing it away from packet on top of two others in right hand.

"Five."

False count next card.

"Six."

You have in reality now three cards in right hand and six in left packet. Audience, however, believes that you have counted six cards into your right hand and have six left in packet.

The six cards left may now be counted fairly.

"Seven - eight - nine - ten - eleven - twelve."

TIME and RHYTHM are the important elements in False Counting. Count the cards fairly fast. Be sure to keep the time and rhythm in straight counting and false counting the same.

If you have difficulty in pulling card back onto left packet with left thumb, do not worry about it. The time and rhythm of your count is more important than this. The ability to do this will come to you with practice.

Practice the False Count until you have it down fairly well and then try it out on someone without letting him know what you are trying to do.

To gentleman on right, say,

"And I shall ask you to hold these cards. Take them with your right hand and hold them up on your right lapel."

Give packet to spectator and then place his right hand with the cards on his right lapel at the button-hole. Fig. 17.

The reason for doing this is to place the cards out of the line of vision of the spectator. This keeps him from counting the cards too. Occasionally you find an assistant who works against you and is contrary. Placing the cards in this position will forestall any such difficulty.

"I was going to tell you to place them against your heart, but it is over on the left and I want to do the trick RIGHT."



FIG. 17

Pick out some intelligent looking person in the audience and ask him to call out any number between one and five.

"Will you please give me any number between one and five?"

IN THE MAJORITY OF CASES THE PERSON WILL SAY THREE. It is a psychological fact that this number will be called in most cases when you ask for a number between one and five.

We will carry on the experiment now just as if the spectator had called Three. Later on I will tell you the method of procedure if the numbers one - two - four - or five are called instead of three.

"The lady (or gentleman) says 'THREE.' That was your own free choice, was it not? You could have selected one, two, four, or five. But she says 'Three.' Then three it shall be. Now, note how matters stand, for I am going to show you an experiment in miracle magic that you will remember as long as you live. The gentleman here counted twelve cards into my left hand and twelve cards into my right hand. They were recounted to prove the number to be correct. At no time have my hands been together while they held the cards. The gentleman took the twelve cards himself from my right hand and wrapped them securely in his handkerchief. The remaining twelve cards were recounted and placed on this other gentleman's lapel. I called for a number -- any number -- and the lady said, 'Three.' What I intend to do now is to cause THREE cards -- the number selected -- to pass from the packet on the gentleman's lapel to the packet in the handkerchief which this gentleman on the left is holding. Not One, Two, Four, or Five cards -- but Three. I shall pass the cards invisibly. Night-time when all is dark is the best time to have the cards go invisibly. When the CARDS PASS IN THE NIGHT, then you cannot see them. As we are in the light, however, we will have to pretend we are in the dark, and if your imagination is good you can imagine inky blackness between the two gentlemen. Just right for the spirits to work in. Now, I shall take a card from the gentleman here."

Pretend to take a card from gentleman at right. Hold

up right hand as though you had a card in it.

"I have a card here in my hand, but as we are in the dark you cannot see it. I shall toss it to my friend here."

Make tossing motion to gentleman on left.

"You could not see it, but did you feel it?"

Gentleman usually laughs and says, "No."

"Perhaps you are not feeling so well."

If he says, "Yes," say, "Ah, the gentleman is feeling pretty good this evening."

Pretend to take another card from packet at right. Hold up right hand as though you held card.

"Now I have another card, but the darkness, of course, again prevents you from seeing it. Again I toss it to the gentleman."

Make tossing motion to gentleman at left.

"Of course, you felt that one."

Perhaps gentleman nods a little this time.

"See – he is feeling better already. Suppose we actually see whether the cards are passing over to the gentleman. I'll blow away the darkness."

Blow into the air as if you were blowing out a candle.

"Well – well – it's light again."

To gentleman at right.

"Will you please give me the cards?"

Take the cards and hold them in left hand.

"I will show you that I have really taken two cards from this packet. Two from twelve is ten, is it not?"

FALSE COUNT the nine cards in the packet. Do your false count on the second card to make the nine cards count ten.

Count each card loud and distinctly to convince audience that you hold ten cards in your hands.

"The two have gone. But you said you wanted three to go. Well, all I have to do is to make it dark again. There you are. A total eclipse. I will now take another card from the pack."

Pretend to take another card with right hand and hold up hand as though you held card in it.

To gentleman at right.

"Will you please count the cards yourself to see whether I am holding a card or not?"

Give the gentleman the nine cards.

"Count them into my left hand one at a time."

Spectator counts cards.

"One, two, three, four, five, six, seven, eight, nine. So you see I am really holding the tenth card. Now I place it back in the pack and I'll count the cards again."

FALSE COUNT the cards as ten.

"One and nine makes ten. Now take the card out again."

Pretend to take card out again and hold it in right hand.

"Count the cards again and we have nine."

Cards are counted again.

This repetition cannot help but convince the audience that there are ten cards (though you really have only nine) and that in some mysterious manner you get a card out and into the packet.

This point of repeating and emphasizing a certain fact or supposed fact is a great thing in Magic.

"So all I have to do is merely to toss the card through the darkness into the handkerchief. If the gentleman will count the cards himself he will find that instead of holding twelve cards he now holds fifteen. The extra three cards are those which passed over from this other packet. Now blow away the darkness."

Blow again.

"And it is light again. Count the cards slowly into my left hand."

Hold the packet of nine cards in right hand.

Spectator counts the fifteen cards into your left hand and you count with him, especially accenting THIRTEEN, FOURTEEN, FIFTEEN.

Bring the packet of nine cards from right hand over on top of those in left hand but keep them separated by little finger of left hand.

Thank the gentlemen for helping you. Just as the one on left starts to turn and go, PLACE RIGHT HAND OVER CARDS AND PALM THE NINE CARDS. Then grasp his right lapel with your left hand and open his coat.

"Pardon me, sir, before you go --"

Reach up under his coat to a point under and a little behind his right shoulder. Fan cards out from right palm and bring them out so that audience can see them.

"Before you go I'll take those few cards of mine which you have up under your coat."

This last move is a good COMEDY touch. This you will find it to be a good finish after you are able to palm the cards successfully.

Back of right hand is toward audience and they do not suspect that you have cards in hand. You put your hand under the spectator's coat quickly and when you suddenly fan the cards and produce them, it causes a stir of surprise and amusement to run through your audience.

WHAT TO DO IF THE NUMBERS ONE, TWO, FOUR, OR FIVE ARE SELECTED INSTEAD OF THREE

The test of a real magician is his ability to meet emergencies – the ability to carry on his effect even when unexpected things arise during his performance.

According to a law of psychology when a person is asked to call a number between one and five, he will call three in most cases. In performing this effect you transfer three cards from one packet to the other, thus making fifteen cards in one packet and nine in the other. You are counting on the working of this psychological law to make the spectator call the number three.

You must, however, be prepared for emergencies -- for the times when spectators will call numbers other than three.

If the spectator calls number one, you say,

"I want any number between one and five."

If number five is chosen, the above also applies.

The spectator then thinks that you want number two, three, or four and will choose another number.

If number two is called, you must change your patter to suit this number instead of three. You played up and emphasized the fact when number three was chosen, but with number two do not do this.

Do not for a moment let your audience know that number two is not the number you wanted. They must think that any number chosen is all right.

Perform your experiment to the point where two cards have passed. Prove this by FALSE COUNTING the nine cards to be ten. Then continue in this way:

"I have caused the two cards which were chosen to pass. Now would you like to have me explain to you how the cards pass over? All right, this is the way it is done."

From this point you may complete your experiment with the third card, supposedly explaining the effect by passing a third card. Use the patter about causing the card to pass in the darkness. Pretend to take the card from the pack, replace it, and take it out again just as you do when number three is selected by spectator.

If number four is chosen, start your experiment this way:

"How would you like to see the cards pass--VISIBLY or invisibly?"

Most people would like to see them go visibly. They want to see how it's done and perhaps expect the cards to fly through the air.

"VISIBLY? Then visibly you shall see them go. (To gentleman on right) Will you please give me one card?"

Gentleman gives you one card.

"You are certain that there is just one card? Fine. Now I will carry it VISIBLY over to the gentleman at my left and have him place it with the other cards in the handkerchief. Take the card, sir?"

Gentleman places it in handkerchief with other cards.

"One card has passed. How many did you say you wanted to pass, sir? Four? All right, we will pass another one VISIBLY."

At this point a snicker runs through the audience for they think you are just being funny.

"What's that? It is no trick to do it visibly? Well, maybe it isn't, but you said you wanted the cards to go visibly, so visibly they are going. You can all see them, can you not? What's that? You would rather see them travel INVISIBLY? Then we'll have them go invisibly."

One card has been passed to the packet in the handkerchief so that you now have eight in the packet held by spectator at right. You may now complete the experiment, pretending to pass three more cards. You must change your patter, of course, to conform to the needs of this occasion.

NOTE:

Another version of this experiment which I use is this: Instead of the darkness idea I use the spirit card idea. I say that I am causing the spirit of the card to travel from one pack to the other. I tell the audience that I do this by dematerializing the card and then materializing it again.

When I hold the invisible card up I use this patter:

"Perhaps some of you cannot see the card. The reason for this is that I am holding the spirit of the card which I have dematerialized. The card in its spirit form vibrates at the rate of four million times a second so that you cannot see it."

You see what opportunity you have for using your imagination in Magic. Give it full play and you will be delighted at the results you get in patter and in putting effects across.

THE CARDS UP THE SLEEVE

This is another old card classic. There are many methods and routines used in performing this effect. Each performer uses a variation of the experiment which best suits his

individuality. After you have mastered the trick as I teach it to you, you may start blending in other principles or varying parts of the effect to develop a routine which you like best.

In this effect STUDY YOUR MISDIRECTION CAREFULLY and MASTER YOUR PALMING.

This effect is a good one to use after CARDS THAT PASS IN THE NIGHT. It is impromptu and can be performed on any occasion.

EFFECT:

Performer counts twelve cards from the deck, holding them toward the audience so that they can be seen. Cards are held in left hand. Magician pulls out right trousers' pocket to show that it is empty. Performer says that cards will pass invisibly up his sleeve into his empty pocket. He clicks the packet in his left hand and then removes a card from his right pocket. This is repeated until the twelve cards have passed one by one, apparently through the performer's sleeve, into his pocket.

PARAPHERNALIA:

1--A deck of playing cards.

SECRET AND PATTERN:

To Perform:

If you use this effect after THE CARDS THAT PASS IN THE NIGHT, you may start with this pattern:

"Perhaps you would like to know just how I cause the cards to travel in the darkness. I will explain it to you in the light. First, you must have twelve cards."

Count off twelve cards from deck, calling the number of each one distinctly so that audience will be sure that twelve have been counted. Hold faces of cards to audience so that spectators see them and can perhaps remember a few.

Place rest of deck on table. Transfer the twelve cards from right to left hand.

"We have twelve cards."

Fan the cards with faces toward audience, using both hands in doing it. Close fan and insert little finger of left hand to separate top three cards. See Figures 2 and 3 of this lesson for method of doing this.

Stand with right side turned a little toward audience. Extend left hand out, holding backs of cards toward audience.

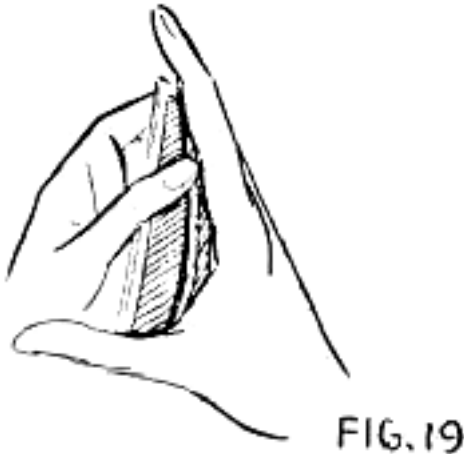
If you are performing on a stage you may call up a spectator to assist you. If you are performing in a parlor you may have a spectator remain seated while reaching into your pocket.

"Will you, sir, please reach into my right trousers' pocket to see that my pocket is empty and that all is fair?"



Spectator reaches into pocket and convinces himself and the audience that pocket is empty.

While spectator is reaching into pocket, turn your right side toward audience. Figure 18.



MISDIRECTION PALMING:

Place right hand over cards. With aid of little finger of left hand, palm the top three cards of the packet in right palm. Figure 19.



Hold the other nine cards in right hand also to make it appear that you merely transferred packet from left to right hand. Figure 20.

"You are convinced, are you not, that there is nothing in my pocket?"

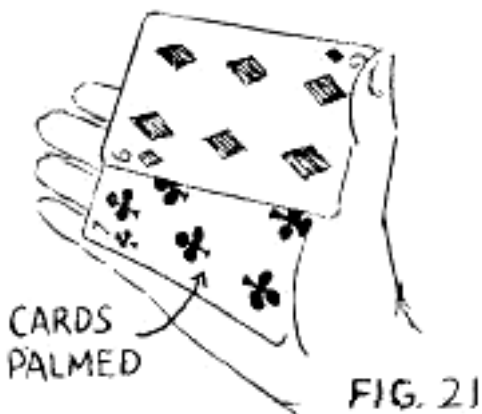


Figure 21 shows position of cards in hand. Three cards are palmed in right hand and remaining nine cards of the packet are held by thumb and forefinger.

The audience sees only the back of your hand.



Place the packet of nine cards into left hand again and draw right hand with palmed cards away toward trousers' pocket. Figure 22.

FIG. 22



POCKET CONCEALMENT:

Put right hand into right trousers' pocket and push the three cards into the upper corner. Hold them there a moment with thumb. Figure 23.

(12-13)

FIG. 23



FIG. 24

With tips of fingers bring out the pocket. You will find that pocket can be drawn out and shown empty even when there is something in it. Figure 24. Replace pocket.

NOTE THE USE HERE OF EMPHASIS. You requested spectator to reach into pocket. He found that it was empty. Now you pull out pocket and show it to be empty. The audience is in this way convinced that you have nothing in your pocket.

"I will now recount the cards to make assurance doubly sure."

FALSE COUNT the nine cards as twelve. Refer back to the first effect in this lesson for explanation of false counting.

Count the cards one at a time aloud. ALWAYS HAVE BACKS OF CARDS TO AUDIENCE in this form of false counting. There is danger of detection if the audience can see the faces of the cards for they are likely to notice when the same kind of card remains in sight for two counts.

"Twelve cards."

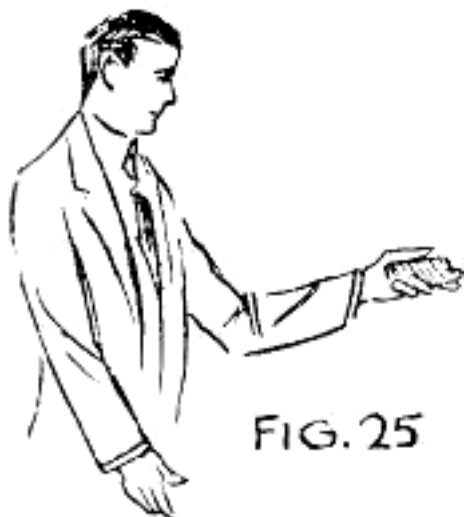


FIG. 25

Hold the packet in left hand, backs of cards to audience.

Your left hand is extended and your right side is turned toward audience. Figure 25.

"What I propose to do is to cause the cards to pass one at a time UP my sleeve and down into my right trousers' pocket."

With right hand draw an invisible line from left hand along sleeve and down to right pocket -- merely touching outside of pocket.

"All I have to do is to click the cards and they will pass up my sleeve. This is quite similar to the way I vanish an elephant or a big bowl of goldfish and water up my sleeve. Sleeves are quite handy. If I want to produce a lady I merely shake my sleeve and a lady assistant appears. If I wish to vanish her, I say 'Hocus Pocus' and she vanishes up my sleeve again. Now, watch closely and perhaps you can see the cards go. ONE --"

Click cards with left thumb. Show right hand empty, fingers wide apart and palm of hand to audience. Reach into pocket with right hand and take out one of the cards. Throw it on nearby table or chair. Figure 26.

"Did you see it go? (Click cards.) There goes another. TWO --"

Reach into pocket after showing right hand empty. Throw second card on table.

A few spectators may have heard of palming and may think that you palm the cards in some way so whenever you can do so, show right hand empty before reaching into pocket.



FIG. 26

"I hear someone saying to himself, 'I wonder whether those cards really do go up his sleeve and into his pocket.' Let us see."

FALSE COUNT the nine cards as ten.

"Two from twelve leaves ten. You see two cards have passed. Now again. (Click cards.) THREE --"

Count cards out slowly so that all will be thoroughly convinced that you have nine cards.

Fan cards again as you did in the beginning of the effect. Close fan and insert little finger of left hand to separate six cards from remaining three.

"I will ask the gentleman here to reach into my pocket himself to see whether the third card is there."



Turn your right side to audience. As spectator reaches into pocket, place right hand over cards again, PALM THE SIX TOP CARDS in right palm. With tips of fingers of left hand turn up the three cards with faces toward audience, using thumb and first finger of right hand as pivot. Figure 27.

The effect is that you have transferred packet of cards to right hand and turned it over so that audience could see face of bottom card. Audience is absorbed in watching spectator who is reaching into your pocket and may not even see this move at all.

When spectator removes third card from your pocket, take three cards in left hand again and reach into pocket with six cards palmed in right hand.

Repeat move of pushing cards into upper corner of pocket, holding them with thumb, and pulling out pocket to show that it is empty.

"You are sure, sir, that there was nothing else in my pocket?"

Gentleman responds, and you push pocket back again.

"Now watch again. (Click cards with left thumb.) Up the sleeve goes the fourth card and here it is in my pocket."

Remove a card from pocket and place on table.

"Next."

Click cards. Then reach into pocket and PALM one card.

"I thought it went into my pocket but I guess it didn't."

Bring right hand out of pocket with palmed card and place hand behind left knee. Be careful always to have back of hand to audience when you are palming cards.

"It seems to have traveled down behind my left knee."



FIG 28

Turn hand over and bring card out, holding it by thumb and tips of fingers of right hand. Figure 28.

This effect of apparently reaching up with tips of fingers and thumb bringing out a card is an important one. Practice palming a card, moving it about to various places, and then suddenly getting it to the tips of the fingers and thumb and suddenly producing it. By pressing card against some surface, in this case, the knee, you will have no difficulty in getting it from your palm to the tips of your fingers.

"They wander around sometimes."

Click cards. Reach into pocket and take out another card. Place it on table or chair.

"That one went all right."

Click cards. Take another card from pocket and place with the rest on table or chair.

"Up the sleeve and into my pocket."

Click cards. Reach into pocket, palm card, and bring hand out.

"That's funny. Oh, I see it got stuck at my elbow."

As you say this, reach up behind left elbow and bring out palmed card with finger tips and thumb of right hand. Place card on table.

"They get stuck in the joints occasionally. How many have we left?"

FALSE COUNT the three remaining cards as four.

"One - two - three - four. Four cards remain."

Click cards and then count the three cards slowly as three.

"Please reach into my pocket and remove the card."

Assistant reaches in and takes out the remaining card in pocket.

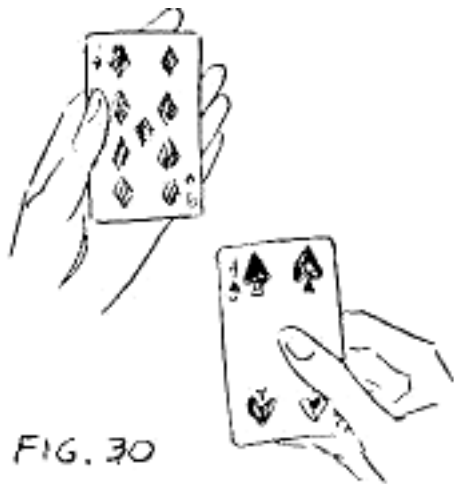
"We now have three cards left."

SELF-CONTAINED CARD VANISH:

Show cards separately and then square them up and hold them in left hand with faces toward audience.

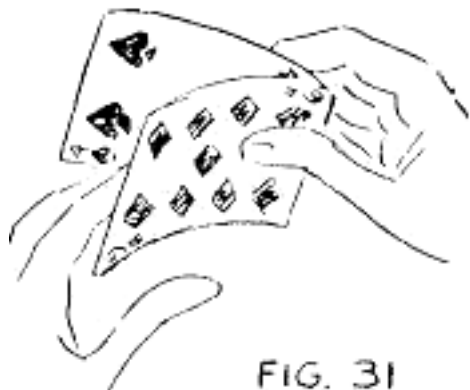
Hold them as shown in Figure 29. Click cards again.





With right thumb slip the first card down away from the other two. Hold the remaining two cards in left hand tightly as one. Figure 30.

"One card."



Place the two cards held as one on top of the first card. Hold tight with right thumb. Snap cards with fingers of left hand as you put them down. This makes it appear that you have only two cards. Fig. 31.

"Two cards."

You have apparently vanished a card.

Square up cards perfectly so that the three will look like one card and hold them in left hand.

Snap face of card with right second finger.

"Pass."

Turn cards over as one card and snap them on the back with finger.

"One card left."

The snapping back and front emphasizes the effect of holding only one card.

In my work I actually throw three cards from right to left hand and they do not come apart. You will find many uses to which you can put this principle of showing three cards as one. As you study, new ideas may present themselves to you for using this principle.

"Now the last card."



FIG. 32

BACK TO FRONT HAND CARD VANISH:

Place the three cards as one with backs to audience on the back of right hand. Grasp edges under first and last fingers at about the second joints. Fig. 32.



FIG. 33

Pass left hand over cards on back of right hand. Fig. 33.

As you do this, turn fingers and cards down into palm of right hand. Bring out second and third fingers, then straighten all the fingers. Fig. 34.

(12-17)

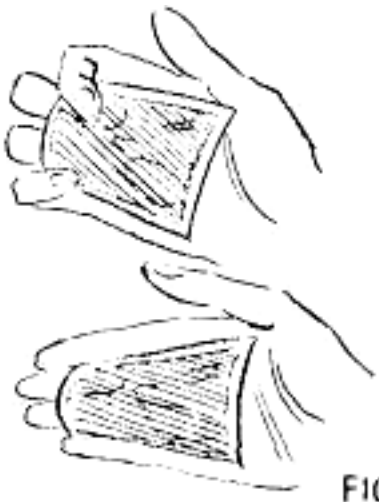


FIG. 34



FIG. 35

As left hand leaves right hand, it should be kept closed as if it had taken card from the right hand and closed around it. Cards are now concealed in palm of right hand. Fig. 35.

Bring left hand about eighteen inches away from right and open it slowly to show that card has disappeared.

Place right hand in right trousers' pocket and bring out the cards one at a time.

"One - two - three."

Note -- Learn to do this effect also without having gentleman reach into pocket. In stage work a spectator may not be near enough - or it may not be advisable to use a committee.

* * * * *

VARIATIONS:

The preceding effect may be presented in a little different way.



FIG 36

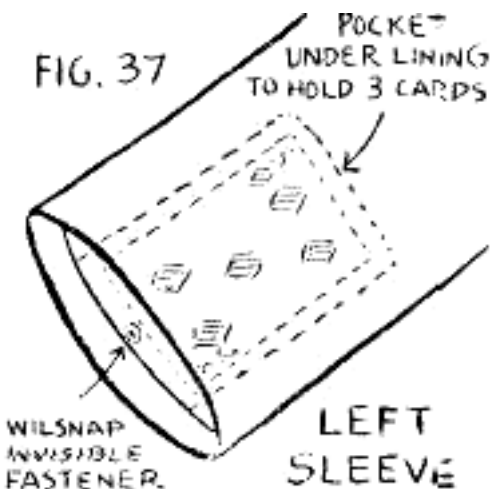
Before you begin the experiment place two cards in your upper left vest pocket, faces toward your body. Then while you are performing and have passed about six cards to pocket, click a card and pretend that it did not go into pocket. Start looking for it and reach up under coat with right hand. Take the cards from vest pocket quickly and carry them up under shoulder. Grasp left side of coat with left hand and open coat. Bring out the two cards fanned out, backs to audience. Fig. 36.

"That time two went up together and, as a result, got stuck at my shoulder. Let them now continue on their way."

Let go of coat with left hand. Reach up under left side of coat with right hand and quickly put cards back into upper vest pocket. Then move hand up to shoulder so that audience can see coat lifted, giving the impression that you placed the cards there.

"One - two -- there they go. And here they are."

Reach into trousers' pocket and take two cards out. Then continue effect as described above.



Another variation of the effect involves some preliminary work. Have the lining on your left coat sleeve opened and pocket sewed in large enough to hold several cards. On the edge have a snap fastener sewed on. Fig. 37.

Before appearing for your performance place two cards in pocket of sleeve. After having passed several cards, pretend that cards got stuck in sleeve. Reach up sleeve with right hand, open snap, and take cards from pocket. Fan the two cards, backs to audience. Then say that they will

continue on their way. Reach into sleeve again, replace cards in pocket of sleeve, close snap. You can now show empty sleeve to prove that cards have vanished.

Then produce the two cards from trousers' pocket.

Little stunts like these add Showmanship to a trick and make it more interesting.

EMERGENCY METHOD:

If you should happen to be before a group, some of whom have seen you perform this experiment before and think you use palming, it is best to vary the effect in the way I shall describe here. These spectators are watching you closely and you must leave them completely mystified at the end of the experiment.

Slip three cards into your right trousers' pocket beforehand. Then instead of counting off twelve from the deck, FALSE COUNT nine cards off as twelve.

Show pocket empty by method I described above. Start clicking cards. The sharpest eye cannot see the cards go into the pocket now, for they are already there.

Another ruse is actually to count twelve cards from the deck or to have someone else count them, then to palm off six and replace them on top of pack in squaring up the pack and placing it on table. Have six cards in pocket before you start.

* * * * *

CARDS UP THE SLEEVE

(The Shoulder Method)

This is a pleasing variation of the CARDS UP THE SLEEVE effect. Instead of producing the cards from the trousers' pocket they are produced from under the left side of coat at the shoulder.

EFFECT:

Twelve cards are counted from the pack and placed in the left hand. Performer causes the cards to pass one at a time up his left sleeve and takes them out from under the left shoulder of his coat.

(12-19)

PARAPHERNALIA:

1--Deck of Cards.

SECRET AND PATTERN:

To Perform:

Have twelve cards counted from deck and hold them in left hand, separating top three cards ready for palming in right hand.

PALM OFF the three cards in right hand and drop hand a little at side.

"Before beginning this odd experiment I want to tell you about a magician's sleeves. This one has two ends, one at the bottom (point with right hand to bottom of sleeve) and an end at the top."



FIG. 38

Grasp left edge of coat with left hand and make a gesture with right hand to show upper end of sleeve, placing hand on left shoulder. Drop left side of coat. This screens right hand and the palmed cards. Leave cards on upper part of left shoulder. The weight of the coat will hold them securely in place. Audience is not aware of your real move. It appears that you were merely explaining the sleeve. Fig. 38.

"There have been many stories told about magician's sleeves and how things go up and down them. Of course, a sleeve is the only place where a magician could conceal anything, especially a couple of lions, a tiger, a dozen rabbits, a billy goat, a couple of girls, and a barrel of pickled herring. The real problem, however, is 'Just how does the magician cause the various objects to pass up and down a sleeve?' I will explain by causing these cards to walk up my sleeve one at a time. First, we have twelve cards."

FALSE COUNT the nine cards as twelve.

"I will place them in my left hand and when I click them, up will walk a card into my sleeve and travel upwards."

Click cards in left hand.

"Did you see that one go? A little too fast, was it? Well, here it is."

Show right hand empty, fingers wide apart. You must convince audience that you have nothing in your right hand. Reach up under left side of coat and take ONE card from shoulder. Show it plainly. Place card on table.

"One card. Up one end and out the other. Again!"

Click cards with left thumb.

"Up goes the second card."

Show right hand empty again and then take another card from shoulder.

"You see it is a sort of clickety click arrangement. Do they really pass up the sleeve? We shall see."

FALSE COUNT the nine cards as ten.

"Ten cards left. The two have gone. Now watch the cards just as closely as you can so that you will see one jump from the packet in my hand out and into my sleeve."

Click card.

"See that one jump? Here it is."

Take third card from shoulder.

Count nine cards as nine.

Fan cards a bit, then square them up and get little finger under top six cards. Palm the six cards in right hand, then place the three remaining cards in right hand. Refer back to Figures 19 and 20.

Audience believes these three cards to be nine. They do not suspect that you have cards palmed.

Place the three cards in left hand again, click them, and reach right hand up under coat to left shoulder. Place the six cards on shoulder. Take one card out with a quick and snappy movement.

"That's a speedy fellow."

Now produce the next five cards one at a time, varying the manner of producing perhaps two of them.

Reach up under shoulder and pretend that you failed to locate the card. In reality, palm one of the cards in your right hand. With left hand lift left edge of vest, reach up under it with right hand, and bring out card by thumb and finger tips, as you did in the production at the knee.

"That one went so hard it lit down under my vest."

Another time, palm card from shoulder and produce it from right coat pocket or from bottom of left trousers' leg.

"These are getting to be regular sky-rockets."

Produce cards until only one is left at shoulder and you have three in left hand.

Count the three as four, then click cards and take another card from shoulder. Now count the three cards slowly

as three.

TO VANISH THE LAST THREE CARDS:

This is a most important move and one which can be used in many effects to vanish a number of cards. With practice you will perfect this move and become skilled in its use.

The effect is that you just push the cards into left hand which closes on them. Then you open left hand -- and the cards have vanished.

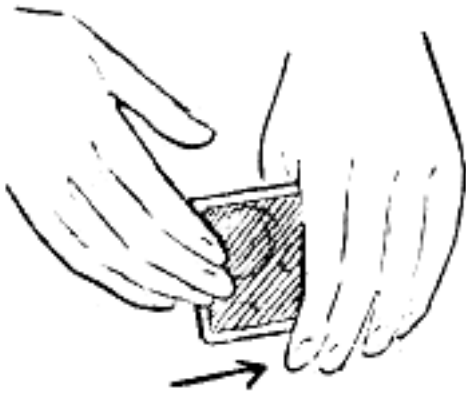


FIG. 39

PIVOT CARD VANISH:

Place the three cards in left hand as shown in Figure 39. This is the way it looks to the audience.



FIG. 40

Push cards into left hand with right fingers, edges of cards just at second joint of right fingers. Figure 40.

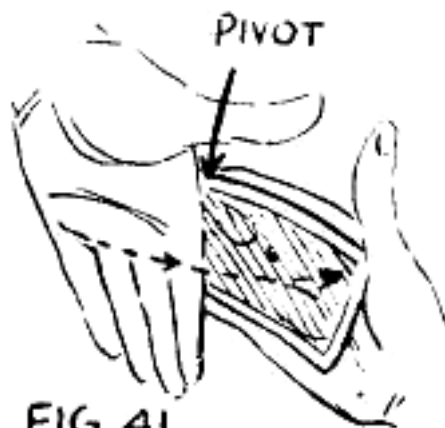


FIG. 41

When cards are almost all in left hand push tips of right fingers forward. This causes card to pivot on first finger of left hand and to revolve automatically into the right palm. Bend right hand slightly and palm the cards. Fig. 41.

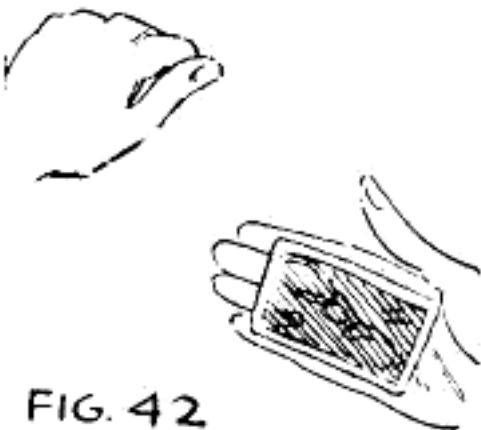


FIG. 42

At the moment when cards are propelled into right hand, close left hand as though cards are in it. Lift left hand up, constantly looking at it. Remember your MISDIRECTION here -- not to look at right hand at any time when you have cards palmed in it. Figure 42.

Open hand slowly and show that cards have vanished.

Now place right hand suddenly into right trousers' pocket, push palmed cards into upper corner of pocket, and bring pocket out empty. Then pull left pocket out empty. Look perplexed as though you do not know where the cards are. Push the pocket back in again. Reach up under coat to left shoulder, then feel around vest for them. Give your vest a shake as though you are shaking something down. Then suddenly reach into right trousers' pocket again and remove the three cards.

Or right hand can be pushed under left side of coat and cards produced from shoulder.

* * * * *

Lesson 13

In the next lesson we continue to study card effects -- this time some very interesting card stabs. With the effects, of course, you learn some more essential principles of Card Magic.

1 -- A deck of cards is divided into two parts. A card is selected from each half by a spectator, remembered, replaced, and shuffled into its respective half deck. The two packets are put together to form whole deck again. The deck is placed behind a piece of newspaper. A spectator stabs through the paper into the deck of cards with a knife. Paper is removed. Deck is opened at place where knife pierced it and it is found that the selected cards are there, one on each side of the knife.

2 -- Spectator selects a card from deck. This card is shuffled back into the deck. The cards are wrapped securely in a piece of paper. Spectator is then given a knife, which he stabs through the paper into the cards. Performer removes the paper and it is found that the knife has located the selected card.

3 -- A card is selected, then thoroughly shuffled into the deck. Spectator runs knife into deck anywhere he chooses. Cards are separated and it is found that the selected card is at place where knife was inserted.

A handwritten signature in cursive script that reads "Harlan Tarbell". The signature is written in black ink on a white background. The letters are fluid and connected, with a prominent flourish over the 'l' in "Tarbell".

TARBELL SYSTEM, INCORPORATED, Chicago.

(12-23)

LESSON 13

REVIEW

Lessons 1 to 12

I know that you have been eager to make rapid progress toward your goal of becoming a Master Magician. There is just one thing I fear that will hinder your advancement -- and that is, neglecting to review carefully your previous work in your zeal to learn more of the secrets of Magic in each new lesson. I like enthusiasm and the ambition to forge ahead in my students, but with this enthusiasm there must be faithful study and practice, very careful attention to detail, and constant review of the principles learned in previous lessons.

Remember that my chief purpose in this course is to teach Magic to you scientifically -- to teach you its fundamental principles. Do not, then, make your chief purpose in learning the course be the learning of the effects. If you do this, you lose the great value of the course. You will never become a Master if you overlook the principles. I cannot overemphasize the tremendous importance of constant practice of principles to give you greater and greater skill in performing the essential moves of the great mystic Art.

Just remember: "It is not the trick that counts most, but the way you do it."

I want you to stop at this point for a thorough review of the twelve preceding lessons. And after this, with each day's study on a new lesson, spend an equal amount of time in review. You cannot accomplish your review all in one day, but arrange to cover a certain amount each day. I shall outline your review for you here. Keep this as a guide to which you can refer in your study.

Take all your lessons before you. Turn back to lesson 4, page 4. There I summarized the principles of Lessons 1, 2, and 3. Read over the page and with it as a guide, review the first three lessons.

I have no doubt but that you are by now fully imbued with the Scientific Spirit of my system of teaching Magic. In spite of this, I want you to read again, and to read every few weeks, my section in Lesson 1, on Magic as a Science. I consider it vital that you keep the great idea contained therein constantly in your mind.

Then review my discussions of the fundamentals in the first three lessons. You will be gratified to note how infinitely greater, now that you have actually performed

as a Magician, is your understanding of the Psychology of Magic. Read again the sections on:

The Power of Suggestion.

The Credulity of People.

The Art of Misdirection.

Do this to confirm for yourself your belief in the great power over other people which you have as a Magician. Apply this psychology to the effects which you have learned. Pick out a certain experiment and study it out carefully, noting where you use the Power of Suggestion on yourself and on your audience, where you play on the Credulity of your audience, etc. Analyze your effects every so often from these psychological angles and your mastery of them will increase immeasurably.

Now go over carefully again the fundamentals and principles of:

Naturalness of Hands.

Angle of Visibility.

Finger Palming.

Thumb Tip Manipulation.

Continue with Lessons 4 and 5, in which you learn the principles employed in Paper-Tearing Effects. In these lessons you get:

Palming of an object.

Thumb Tip Concealing in Box of Matches.

Your First Construction Work in Making your own Paraphernalia.

How to Accent a Point in Magic.

Some Sleight of Hand.

Discussion of How Magic Develops your Personality.

Lesson 6 teaches you Cut Cord Effects. Read over again the section on:

Magic a Great Aid in Business.

Here you also get your Introduction to Comedy Magic.

Lesson 7 gives you Rope and Tape Effects with the great Fake Joining Principle.

Study your Patter carefully in all your Effects.

Lesson 8 is a Mathematical Lesson. Read section on:

Magic is Educational.

Study the Mathematical Principles.

How to Force a Sum.

Some of the Psychology of Numbers.

Lesson 9 is your introductory lesson in Card Principles and Mechanical Arrangements for Card Effects. The principles require constant practice for perfection.

The Simple Pass.

The False Shuffle.

Double Card Lift.

Slip Change.

Palming of a Card.

Mechanical Arrangements:

Closed Card Case Production.

Slit Corner Envelope.

Doubling First Card in Fan.

Lesson 10 is an extremely important lesson. Read it often to keep fresh in your mind the essential details contained therein:

Confidence and Enthusiasm.

Good Will and Pleasantness.

Dignity.

Personality.

Individuality.

Showmanship.

How to Present a Program.

Arrangement of Paraphernalia.

Arrangement of Audience.

How to Get Volunteers to Stage.

How to Deal with the Wiseacres.

Lesson 11 gives you Rubber Band Effects and Thumb Ties.

Ring Passing Thru Rubber Bands.

The Jumping Rubber Bands.

Rubber Band Thumb Release.

Thumb Tie – Wire and Cord Release.

Lesson 12 continues your instruction in wonderful Card Magic Principles:

Card Transfer.

False Count.

Misdirection Palming.

Pocket Concealment.

Self-Contained Card Vanish.

Back to Front Hand Card Vanish.

Pivot Card Vanish.

Mechanical Arrangements:

Sleeve Pocket.

Shoulder Concealment.

LESSON 13

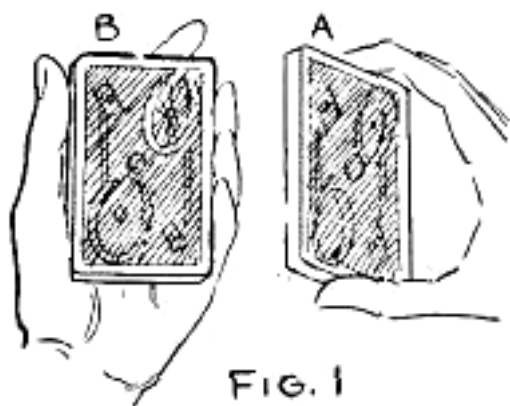
In this lesson you learn some interesting stabbed card effects. I also teach you here the REGULAR PASS.

In Card Magic one of the most essential principles to know is how to get a card that is placed in the middle of the deck to the top or bottom where it can be kept track of.

Magicians for a long time have depended on what is known as THE PASS. It has answered the purpose to a certain extent, but it is not a perfect principle. It must be performed in a perfect manner to be undetectable to watchful eyes. There is usually a flash of the cards which might lead a spectator to suspect something.

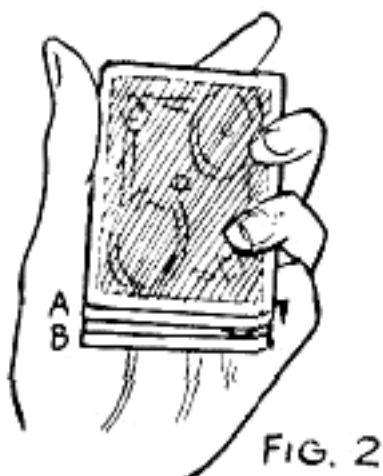
THE SIMPLIFIED PASS, which I taught you in Lesson 9, is best for the student as well as the skilled performer. There is almost no danger of detection and this Simplified Pass should be used in preference to the Regular Pass as a rule.

As a Magician, however, you should know the Regular Pass and be proficient in using it. There are times when its use is required and it is effective with proper Misdirection.



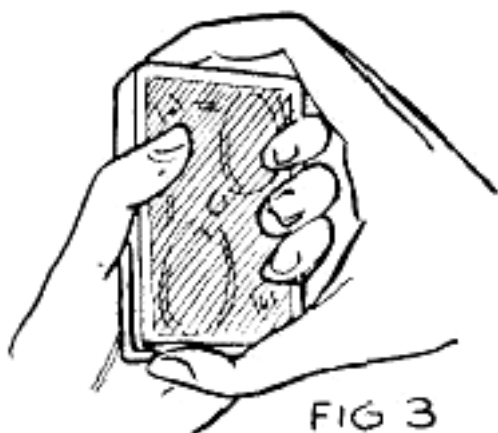
THE REGULAR PASS:

Fan a deck of cards and have spectator select card. Close deck and divide it into two parts, holding upper section A in right hand and lower section B in left hand. Faces of cards are down. Figure 1.

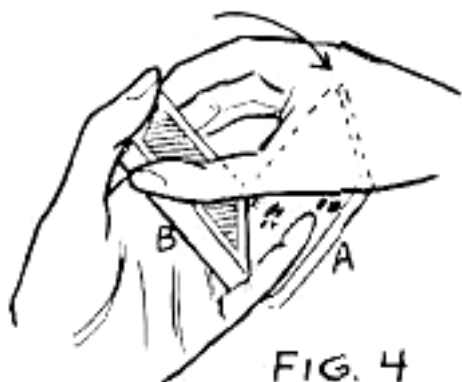


Have selected card returned to deck and placed on section B. Place section A on B, and in doing so, insert little finger of left hand between the two sections. Figure 2.

To the audience it looks as though the two packets have been brought together and the selected card lost in the middle. Keep front edges of cards well together so that audience cannot see that the two packets are separated.

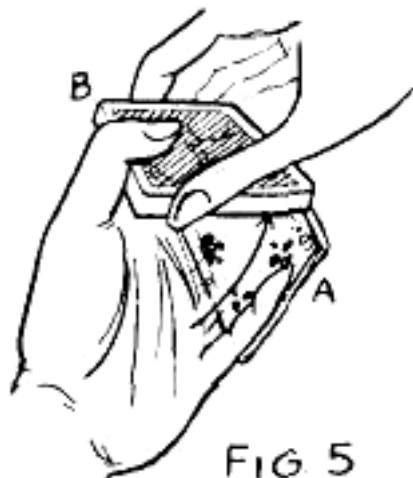


Place first and second fingers of right hand (first joints) on front edge of lower packet B and right thumb on rear edge of B. Be careful not to exert any pressure on top packet A. Figure 3.



First, second, and third fingers of left hand are curved down over top of packet A.

Push up packet A with left little finger. The packet is securely held by little finger on left side and first, second, and third fingers on right side. Figure 4.



Raise packet B with right hand. Figure 5.

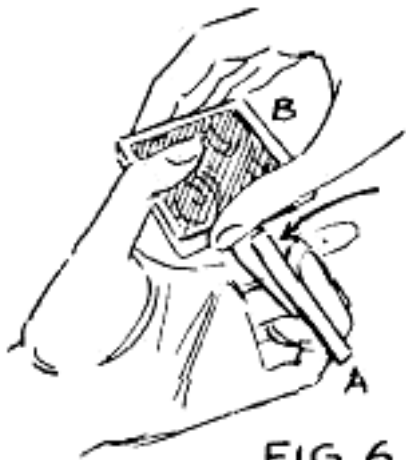


FIG. 6

Curve fingers of left hand back toward palm, pushing packet A back down under B. Figure 6.

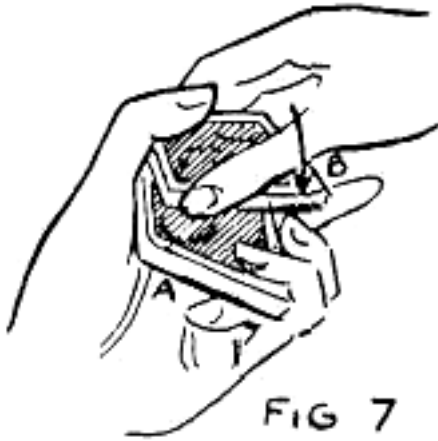
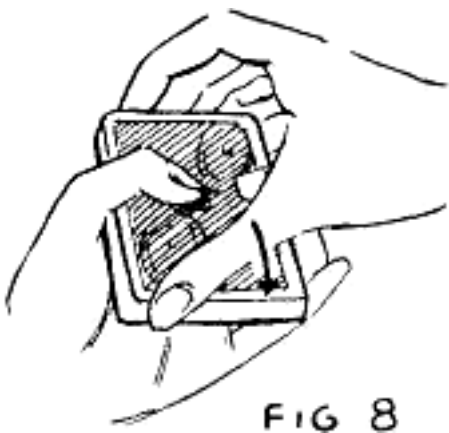


FIG 7

Get packet A down in position which B was in at first. Figure 7.

(13-5)



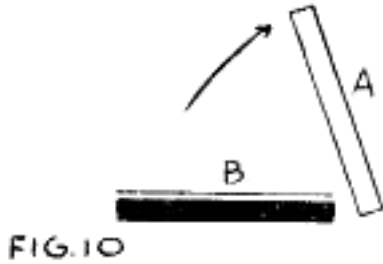
Drop packet B on top of packet A. Figure 8.

The selected card is now on top of the deck.

Study the diagrams, Figures 9 to 14. These show the movements in the PASS. Packets A and B are marked. The line above Packet B designates the selected card.

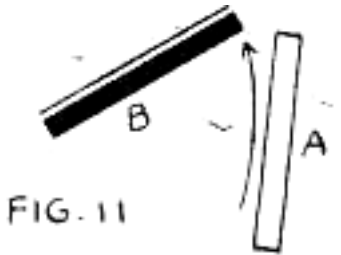


THE PASS must be performed in a flash. It must be done, not as a series of movements, but as one quick move. You must practice it until its performance becomes automatic with you and you can do it almost without thinking.

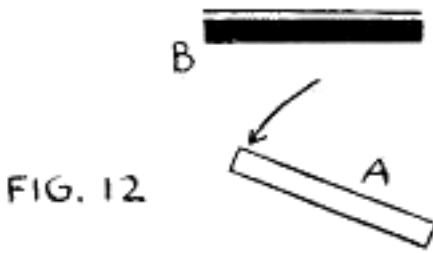


Never look at the pack while you are doing the PASS.

Do not squint your eyes or make grimaces while doing it.



Some magicians close their eyes or do something peculiar while doing some important move like the PASS. You must watch yourself so that you do not give yourself away at a crucial moment by some grimace.



The best angle for doing the PASS seems to be the position in which the performer's right side is turned a little toward audience. Back of right hand and backs of cards are toward audience. Stand in front of your mirror and watch your reflection in the mirror in studying the Angles of Visibility in doing the PASS.



After spectator returns selected card to deck, wait a few moments before doing the PASS. Do not hurry to do it immediately. Wait until the audience is off their guard.



Remember NATURALNESS in performing the PASS. It must not appear that you are doing anything unusual or that you are performing any quick movements. Naturalness, you know, is the secret of good Magic.

When doing the SIMPLIFIED PASS you can go right ahead with it even when the audience is watching closely for there is no danger of detection. And this form of PASS requires no Misdirection.

HOW TO GET A CARD PLACED IN MIDDLE OF DECK TO BOTTOM OF DECK:

This is accomplished by the same method that is used in getting a card to top of deck except for position of little finger of left hand. The little finger, in this case, is placed under the card instead of on top of it, when card is replaced on packet. When packet A is placed on packet B, the selected card becomes the bottom card of A with little finger under it.

When the PASS is performed, packet B becomes the top packet, and packet A with the selected card at the bottom becomes the bottom packet. The selected card is then on the bottom of the deck.

When accomplishing this with the SIMPLIFIED PASS, you must perform it in this way:

Be sure to have backs of cards toward audience instead of the faces. In shuffling the overhand way in the Simplified Pass to get a card to bottom of deck, a different move is required.

Raise top packet A and place on other side of packet B. With left thumb slip off the selected card as you raise packet A again and shuffle towards front of deck, being careful not to disturb bottom card. In this case you shuffle away from audience, whereas when selected card is on top, you shuffle toward audience with faces of cards toward them; and you turn right side a little toward audience, whereas in the other way of working, you turn left side toward audience.

When doing the Riffle Shuffle, selected card at bottom of right-hand packet A is merely allowed to fall first to keep it at the bottom.

* * * * *

The card effects in this lesson are impromptu and can be performed at a moment's notice anywhere. They are suitable for parlor, club, or stage work.

THE CARD STAB

EFFECT:

A deck of cards is divided into two halves. From each half a card is selected and remembered. Each spectator who selected a card returns it to the deck and performer shuffles each into its respective half. The two packets are placed together to make the whole deck again. Performer places the deck behind a piece of newspaper and crimps the paper around the cards. A spectator is given a knife and told to stab through the newspaper into the cards. After this has been done, paper is removed. Deck is then opened at place where knife pierced it, and the selected cards are found, one on each side of the knife.

This is an effective version of an old card classic. In the original version the magician guided the knife himself in locating the cards, but in this variation the spectator stabs the knife into the cards himself and yet the cards are located.

PARAPHERNALIA:

- 1--A deck of cards (preferably a new one).
- 2--A table or pocket knife, or dagger.
- 3--A half sheet of newspaper.

To Perform:

Divide deck of cards into two halves. Place one half on table. With other half in hands, walk up to spectator and ask him to select a card.

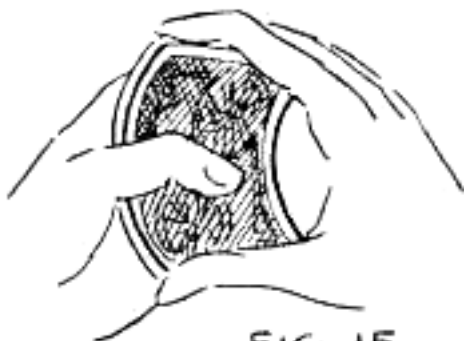
"Will you please, sir, select any card?"

Fan cards and give spectator free selection.

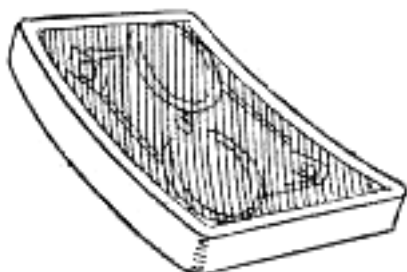
"Take the card from the pack, remember it, and if you care to, show it to someone else. Then place it back into the pack."

Open cards into two sections and have spectator place card on top of lower packet B. Then place packet A on packet B, keeping packets separated by little finger of left hand.

Do the SIMPLIFIED PASS, which brings the selected card to the top by shuffling.



Under cover of right hand bend the cards backward. They should retain a slight curve when put down -- not enough to get the attention of the audience. Figure 15.



Lay the cards on table with narrow edge toward audience. Keep long curved side away from spectators so that it will not arouse suspicion. Figure. 16.

Pick up other half of deck.

"From this other half I should like to have another card selected."

Walk over to another spectator, fan pack, and have him remove card.

"Thank you, just any card. Make mental note of it and place it back in the middle again. We will shuffle these cards well also."

When card is returned to second section of deck, as before place little finger of left hand over it. Do the SIMPLIFIED PASS in reverse form so that selected card is on the bottom of this section.



Under cover of right hand bend the cards forward, in the opposite direction to that in which you bent the other half of deck. Figure 17.



FIG 18

Hold cards in right hand, and with left hand pick up the half deck lying on table. Place both packets together, the section held in right hand on top. Figure 18.

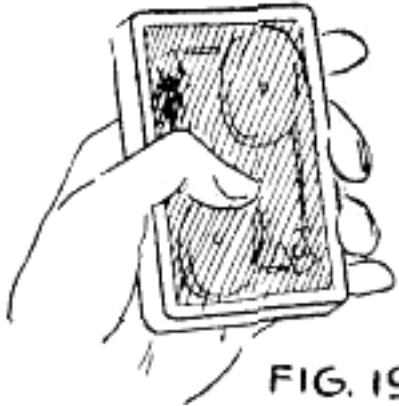


FIG. 19

Hold both packets in left hand, pressing them together tight with left thumb. If this is not done, the space between the two sections of the deck caused by the opposite curves will be apparent to audience. To the audience it appears that you put the two halves of deck together without in any way keeping track of the selected card. Figure 19.

In spite of the fact that the thumb holds the two sections together, when it is removed the packets spring back to the curves and leave a space between them.

Request a spectator to come forward to assist you. Have him stand at your left and a little in front of you.

"You will help me, I know. I need a good, strong, handsome man with magic power. I believe, sir, that you possess this rare power which I am seeking."

Pick up knife from table.

"This is not a common knife, I assure you. It has strange powers in the hands of some people. Just hold it, sir, in your right hand."

Give knife to gentleman assisting.

"We shall need this piece of newspaper."

Pick up paper from table with left hand.

"Not so much for the news, but for wrapping or dress purposes, or for hiding the cards -- sort of hide-and-go-seek -- so 'twere."

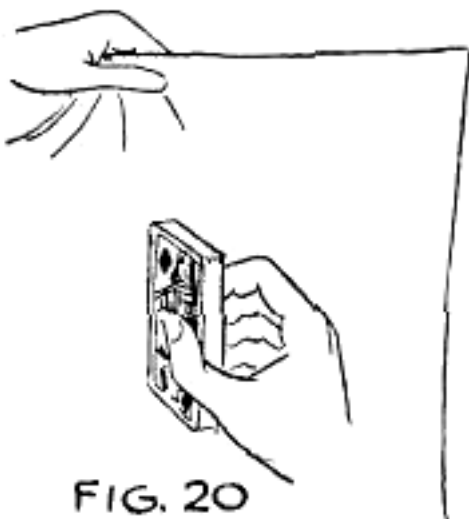


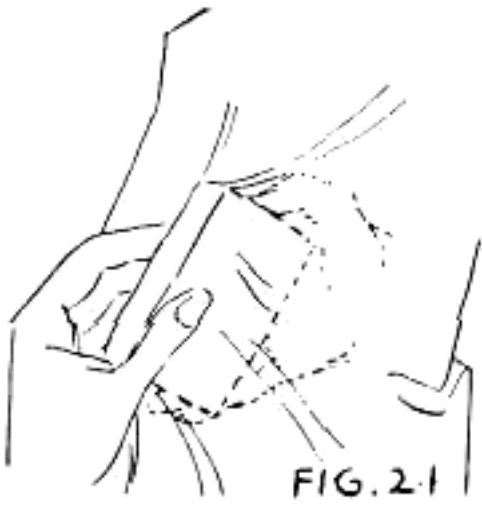
FIG. 20

Hold cards in right hand. Place sheet of paper in front of right hand, first showing paper both sides to prove absence of concealed articles or any trickery. Figure 20.

Push paper down around cards enough to show audience that paper has been placed over cards. Take hold of deck with paper over it in left hand.

Shift position of right hand under cover of paper so that you can hold pack by top and bottom. Figure 21.

(13-9)



Still holding newspaper in left hand, draw deck back from paper a little so as to give you free play. The newspaper tends to flatten out where cards were.

Push down on cards with right thumb and up with fingers. This pressure causes cards to bridge apart with wide space between two sections. Figure 22.

Release pressure and cards come almost together again. This is done to be sure that all is working as it should for final climax. Place cards back against paper again and hold with left hand so that form of cards shows plainly.

To gentleman assisting:

"Yes, that is a magic knife -- a magic knife that has an X-Ray vision that penetrates any object. For instance, it looks right through this paper. Hold it up, sir, and point the blade this way. See, it looks right through this paper and, would you believe it, it has its eye on the two cards that were selected. Even though one card has been shuffled into one half of the deck and the other into the other half, yet it sees them. If you will wave the knife in a circle, it will cause the two cards to become so attracted to each other that they will come together. No matter where they are, they will fly into each other's arms. Are you ready? Wave!"

Gentleman waves knife in circle. Without disturbing position of left hand on cards, look behind newspaper for a moment at cards.

"Yes, sir. There they are together. You must admit that there is magic in that knife. Just think, one wave and the two cards actually come together. But that isn't all. I'll show you something even more wonderful."

This has a comedy touch as the audience has not seen the two cards together and does not believe they are just because you looked. To them it isn't a trick. And when you consider it as such and say you will do another, they smile and wonder whether the next will be as ridiculous.

To assistant:

"Step up a little closer and place the point of the knife against the cards, or rather against the paper covering the cards."

Assistant places point of knife against paper. Figure 23.

"Fine. Now, draw the knife back a foot or so, and then thrust it through the paper and into the cards."

Gentleman draws knife back.

(13-10)



"Right through -- any place."

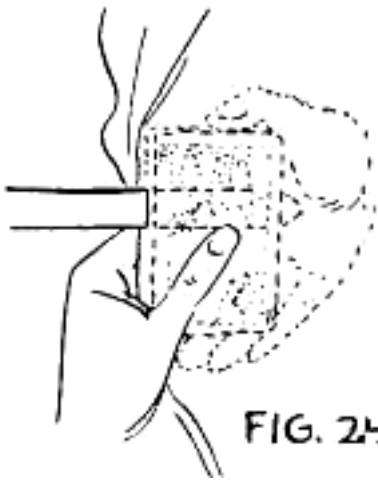


FIG. 24.

Spectator runs knife into pack until it sticks out at other end of cards. While he is doing this, you press on cards as explained before so that knife will go into space prepared for it. Figure 24.

"Hold on to knife tight, and do not let go while I tear off the paper."

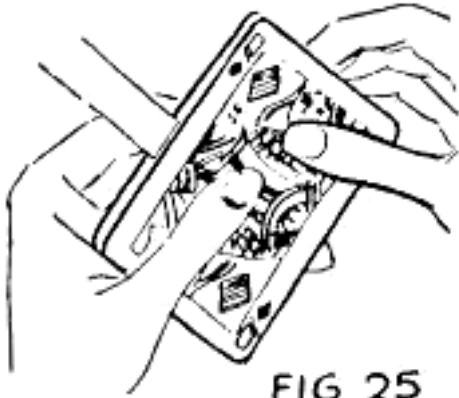


FIG. 25

Remove paper. Keep cards held tight together. Hold deck so that audience can see the knife inserted in the deck. Figure 25.

"I told you that the knife caused the two cards to come together. Now, I am going to show you that the X-Ray powers caused this knife to look right through the paper and find the two cards together -- in fact, to come between them."

Hold lower packet of cards beneath knife blade with left hand and upper packet with right hand. Turn cards so that backs are upward.

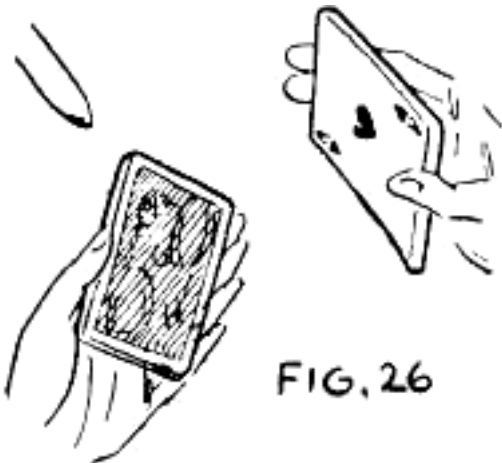


FIG. 26

Raise upper packet and show the bottom card. Figure 26.

"The ACE OF HEARTS. Was that your card? Correct."

We are merely assuming here that the Ace of Hearts was one of the selected cards. Whatever the card is, call it out distinctly and with emphasis. This is a CLIMAX and you must drive home to your audience your remarkable POWER.

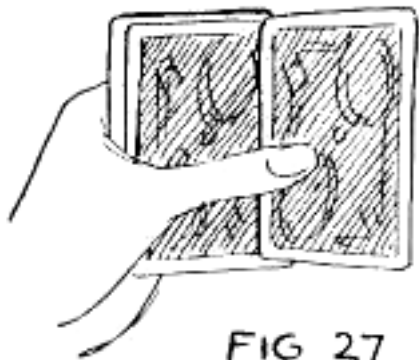


FIG 27

Remove lower section from under knife. Hold it up in left hand with faces of cards toward audience. With left thumb push off top card far enough so that audience can see it plainly. Figure 27.

"And on the other side of the knife -- the TEN OF CLUBS, the other selected card. Right!"

* * * * *

THE X-RAY KNIFE

This is another knife card stab which is very interesting.

EFFECT:

Performer requests that a spectator select a card from deck and remember it. Spectator then replaces card in deck and it is shuffled thoroughly into the deck. The cards are then wrapped securely in a piece of paper. A spectator is given a knife and told to thrust it through the paper and into the cards. Magician then removes paper and shows that knife has located the selected card.

PARAPHERNALIA:

1--Deck of Cards.

2--Piece of newspaper about 8 1/2 inches square or some colored opaque soft paper that can be easily torn.

3--A table knife, pocket knife, or dagger.

SECRET AND PATTERN:

To Perform:

Fan deck out.

"Please select a card. Any one of the fifty-two."

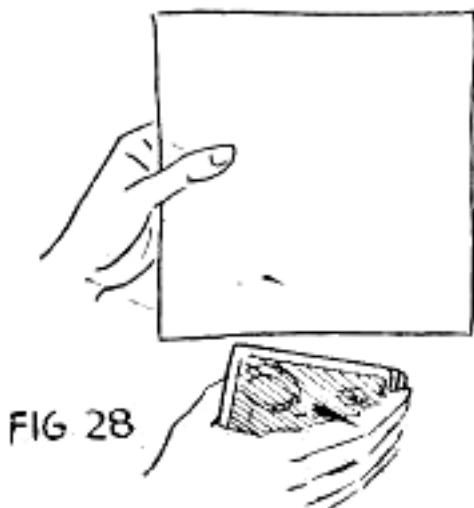
Spectator takes a card.

"Look at it, remember it well, and then replace it in the deck."

Cut deck at about the middle. Have card placed on lower half with little finger of left hand under it. Place upper half of deck on lower half. You now have the selected card as the bottom card of top section with little finger under it, separating top from bottom sections.

Do the SIMPLIFIED PASS, getting selected card to bottom of pack. Be sure to keep faces of cards away from audience.

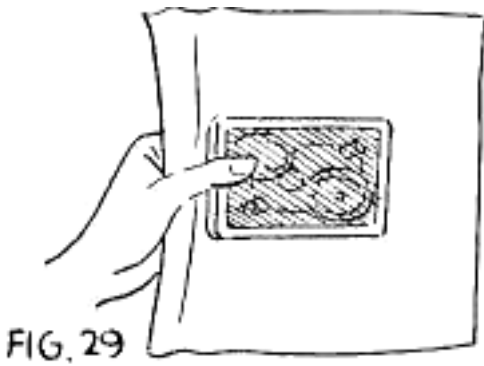
"A little shuffling now and then is relished by the best of men."



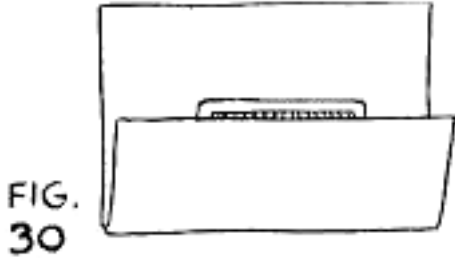
Hold deck with right hand and pick up paper from table with left hand. Figure 28.

(13-12)

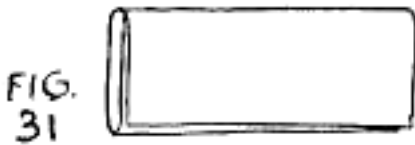
"A part of the daily paper, you see -- both sides."



Place cards against paper, backs toward audience. Hold them in place with left thumb. Figure 29.



With right hand wrap deck in the paper. First fold up the bottom of paper. Figure 30



Then fold down top edge of paper over cards. Figure 31.



And finally, fold both sides of paper over to middle. Figure 32.

"Under cover of the daily news I wrap the cards securely therein. Now, I need a gentleman to hold this package for a while. Thank you, you'll be just the man."

Ask spectator to come up from audience to help you. Have him stand at your left. Pick up knife from table.

"You have heard, no doubt, of X-Ray vision. That is seeing through a brick wall or seeing things that nature did not intend you to see. This knife is no common knife -- it is a miniature X-Ray. The point of this knife can look into the middle of next week -- through the side of a house -- or a Scotchman's pocketbook. (To gentleman assisting) I'll take the package of cards and I'll let you hold this X-Ray knife."

Give spectator knife and take the cards.

"Have you ever done X-Ray work, sir? A gentleman over there thinks I said extra work. No, I said X-Ray work. Hold the knife in your right hand and point the end of the blade toward the package."

Hold package of cards up with right hand, long edge of cards toward spectator.

"Bring the point of the knife up to about an inch from the cards."



Assistant brings knife up toward cards. Figure 33.

"Somewhere mixed up with the other cards is the one which the gentleman over there selected. Can you see it, sir?"

Perhaps not, as it is too well wrapped in paper. But the end of the knife sees it -- it looks right through the paper. Push the knife blade through the paper and into the deck."

Assistant pushes knife blade into deck.

"Hold the knife tight."



FIG. 34

As soon as the knife has been run into deck, move it up and down to cut a slit in paper running to within about a half-inch from each end of the cards. With knife blade again in the middle, push left thumb into space above where knife separates the cards and right thumb into space just below knife. Figure 34.

Pull two halves of cards apart a little. BE SURE THAT AUDIENCE CAN READILY SEE THAT YOU HAVE YOUR THUMBS IN THE PLACE WHERE KNIFE IS.

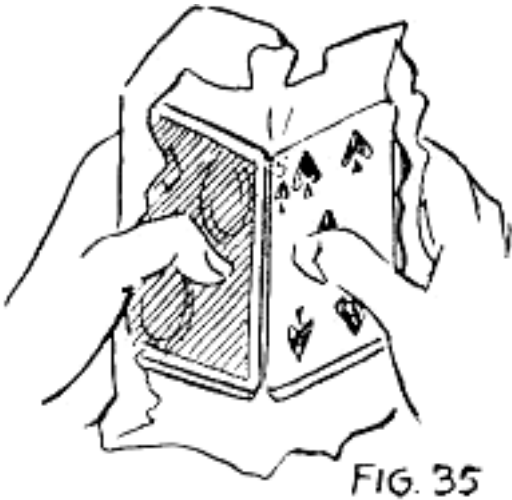


FIG. 35

Now turn slightly toward left, your right side toward audience. As you do so, pull deck downward away from knife and tear halves of deck apart with a sudden, quick movement. Figure 35.

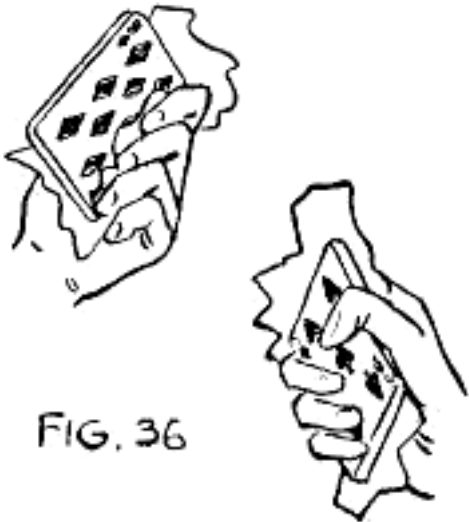


FIG. 36

Tear package completely apart, and as you do so, turn the left hand packet, which is facing away from audience, with face of bottom card toward audience. This must be done very quickly. This shows the selected card to audience. It appears that this card was found by the knife, whereas in reality this card has been on the bottom of the deck all the time. Figure 36.

"The eight of diamonds? Was that your card? Correct."

Make this statement positive and distinct, naming whatever card was the selected one. This is a CLIMAX and should be EMPHASIZED.

The whole movement with the left hand in turning the left half of deck should be very snappy. The audience thinks that the knife was actually inserted at the place where the selected card was. They do not suspect that you turned the cards to face the audience as your left hand swept upward. The cards held in right hand are faced away from audience and are screened by paper and hand so that spectators do not know which way the cards face.

While you are tearing the deck apart, the flat side of cards should be toward audience and not the edges.

"A remarkable knife that -- it never fails to find what it is looking for."

Take knife from spectator and place it on table.

THE MAGNETIC KNIFE

This is another knife location. In this case, the deck is not wrapped in paper.

EFFECT:

A card is freely selected by a spectator. It is then returned to pack and shuffled into it. Spectator is asked to run a knife blade anywhere into the deck. Performer separates cards and shows that selected card is at place where knife was placed.

PARAPHERNALIA:

1--A deck of cards.

2--A pocket knife.

SECRET AND PATTERN:

Have spectator select a card from deck and remember it, then return it to the pack.

Perform the SIMPLIFIED PASS to bring the selected card to the TOP of the deck.

Do the DOUBLE CARD LIFT, showing the two top cards as one to the spectator who selected a card.

"Did this happen to be your card? No? (Replace top cards on deck. Show bottom card.) Nor the bottom card? Then your card is lost somewhere in the shuffle."

Pick up knife from table.

"This is a magnetic knife from the land of 'Floor-no-Hoofa' where magnets grow, -- so called because the people have so much personal magnetism that they walk on the ceiling most of the time. They are a race of stickers."

Request someone from audience to come up to assist you.

"May I make you chief custodian of the Magnetic Knife? You have never been in Floor-no-Hoofa, have you? Will you, as chief custodian and royal executioner, be kind enough to place the blade anywhere in this deck of cards? Just any place you choose, because the knife will go anywhere it chooses anyway. (To gentleman who selected card) And you, sir - will you think hard of your card?"

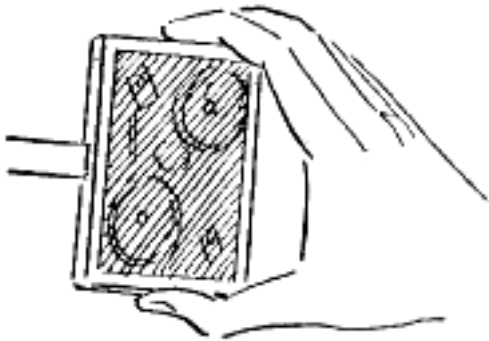


FIG. 37

Assistant is at your left. Hold cards backs up and have knife inserted anywhere in pack. Figure 37.

"Betwixt the magnetism of the knife and the concentration of the gentleman thinking of his card, it happens, naturally, that the knife falls in love with the card and goes to find its loved one."

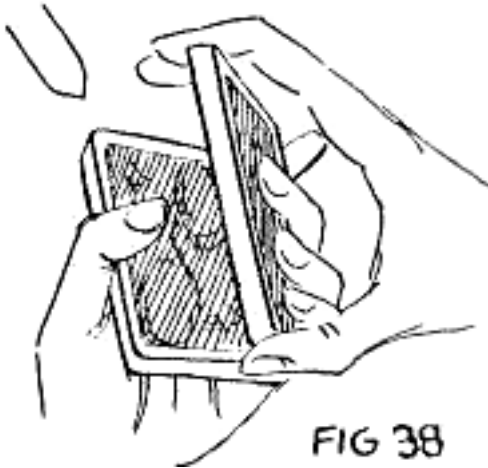


FIG 38

Hold deck securely with left hand and place right hand over section of deck above knife. Here you perform THE SLIP CHANGE (see Lesson 9):

Raise upper portion of deck with right hand, swinging deck away from knife blade. Be sure to have left fingers tightly pressed against right-hand edge of cards. Figure 38.

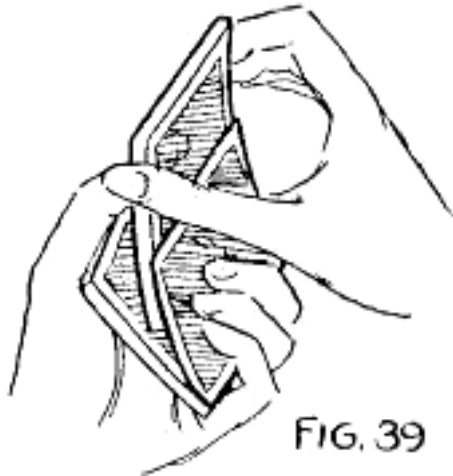


FIG. 39

Swing arms to right about twelve inches, away from knife blade. Under cover of this movement slip upper portion of deck except top card about three inches above lower portion. Figure 39.

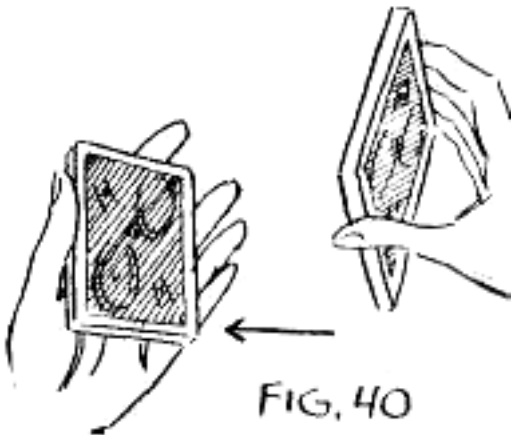


FIG. 40

Selected Card automatically falls on top of lower section. Immediately swing left hand to the left. To the audience it appears that you have just swung the cards away from the knife, separated the two sections divided by the knife, and swung one section to each side. Figure 40.



FIG 41

With left thumb slowly slip off top card of left packet, and as you do so, turn cards with faces toward audience so that audience can easily see selected card. Figure 41.

"The Queen of Hearts. Was that the card? RIGHT!"

* * * * *

You will find your next lesson very interesting as it deals with Card Magic in combination with the use of fruit. You will appreciate the clever principles you will learn:

1 -- An orange is passed around for examination and given to a spectator to hold. A card is freely selected from a deck by another spectator, who tears the card into a number of pieces and retains one corner. The torn pieces suddenly vanish. The orange is cut open, and the selected card is found in it, fully restored except for the corner held by the spectator.

2 -- Performer has a banana examined and a card selected. He says that he will cause the card to vanish and appear in the banana while the banana is held by a spectator. The card vanishes but fails to appear in the banana just then. After special communication with "The Devil," however, it appears in a most mysterious manner. This effect has a good comedy finish.

3 -- A banana is examined and peeled. The audience states the number of pieces they want the banana to fall into. Suddenly it falls apart into the selected number of pieces.

A handwritten signature in black ink that reads "Harlan Tarbell". The signature is written in a cursive style with a large, sweeping flourish over the "T" in "Tarbell".

TARBELL SYSTEM, INCORPORATED, Chicago.

(13-17)

I hope you are progressing well with your review. Keep referring back to Lesson 13 as your guide in your study.

Today we take up the study of several other important principles employed in card effects. These are:

- 1 -- The Force.
- 2 -- The Jog.
- 3 -- The Thumb Palm.

Mechanical arrangements are:

- 1 -- Handkerchief for Torn Card Vanish.
- 2 -- Double envelope (Explained in Lesson 8).
- 3 -- The False Pip.
- 4 -- Cloth Changing Bag.

THE FORCE

The Force is one of the essential principles of Card Magic. It is a means by which you can influence a spectator to take from a deck of cards any card that you want him to take, yet giving him the impression that he has a free choice.

We will assume that the Queen of Hearts is the card you are going to force. To begin with you must have the Queen on top of the pack, holding pack in your hands with backs of cards up. Insert little finger of left hand about half way in the deck and make the REGULAR PASS (Lesson 13). This brings the Queen to the middle of the deck.

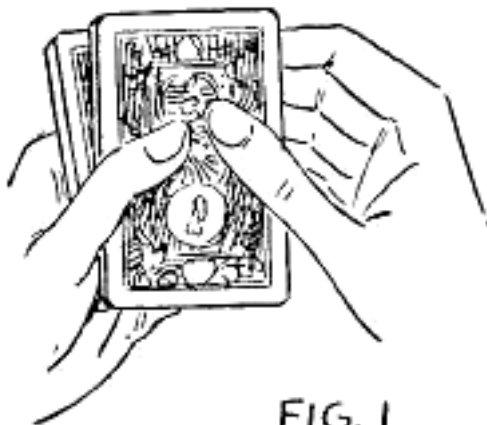


FIG. 1

THE JOG:

The bottom section of cards with the Queen on top of it is left projecting about one-quarter to three-eighths of an inch to the left of the top section. This is called the JOG and is the means of keeping track of the selected card which you are going to FORCE. Left thumb is on top of deck and four fingers under it. Figure 1.

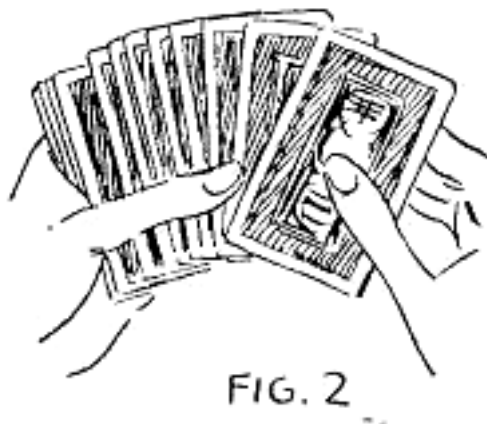
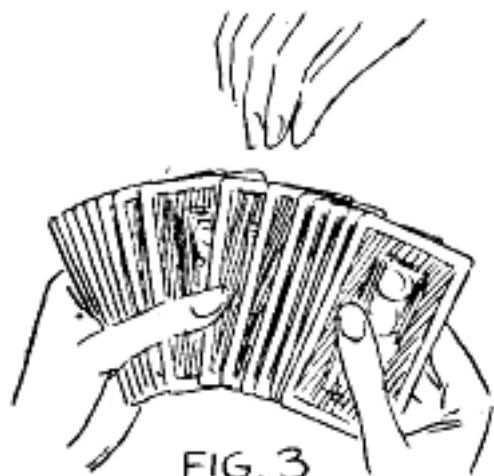


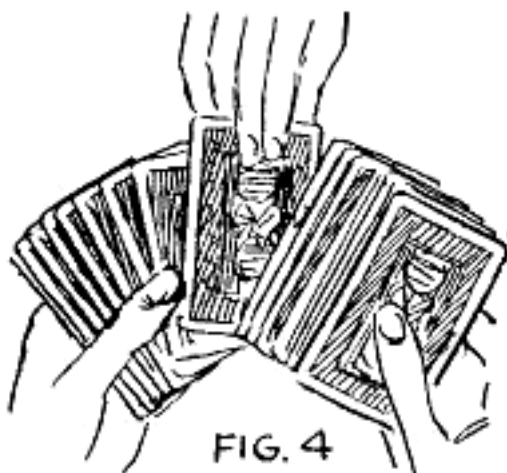
FIG. 2

You ask spectator to select a card from the deck. Begin spreading cards fanwise to the right, starting with the top card. Figure 2.

Keep on spreading cards until spectator is just about ready to take a card, always keeping track of the Queen at the Jog. Figure 3.



As spectator reaches for a card, expose the Queen more than the others and push it slightly, not obviously, forward towards his fingers. Most people will take that card automatically for it is easiest and most convenient to get. It will not occur to them that you caused them to take that particular card. Figure 4.



In the FORCE you use silent suggestion. You do not suggest with words, but with motion. You control the card with your fingers and spread the deck so that the desired card is brought to a point directly in front of the spectator's fingers just as he is ready to take a card. It appears that the spectator freely selects a card and that you are merely being polite in exposing it and helping him to get it more easily.

Forcing seems difficult to the uninitiated, but in reality it is very easy. The Jog is a very simple device for keeping track of the card to be forced, and you will have no trouble with the rest of the Force. Practice it.

At times you will want to Force a card from the bottom of the deck instead of the top. Perform the REGULAR PASS. This brings the card to the bottom of the upper section of deck. JOG your deck as before explained. The card on top of the lower section of deck acts as a key card to show that the card above it is the one to be FORCED.

IN CASE OF EMERGENCY:

When you have members of your audience assist you in an effect, select those who seem to be best educated and refined and those who seem to respond to suggestion. You will seldom encounter difficulties.

There may be occasions, however, when your assistants will prove to be contrary and you must be prepared for the emergency when the spectator will not take the card you are trying to force.

In this case, let this spectator have his free choice of a card. Then force the card on the next person. If you fail again this time, do not be disturbed. Just keep on trying your Force until a spectator takes the selected card.

Say to the first spectator who drew a card, "Pardon me, but what card did you select?" Gentleman names card, for instance, the King of Hearts. You say, "The King of Hearts?" Look at card. "That's Right." Take card from gentleman.

In case more than one spectator has failed to take the forced card, request each one to name his card. You look at the card and say, "That's right," in each case and take the cards from the spectator.

This is a bit of byplay which gets you out of the difficulty, yet the audience thinks you did this on purpose just to have some fun. Now take the forced card and continue with your experiment.

Always be prepared to get out of difficulties. When the wrong card is taken, sometimes you can do another trick with it -- just a short, snappy one -- and then continue with the effect you intended to do.

Another excellent means of forcing a card is the method used in the last effect of Lesson 13, THE MAGNETIC KNIFE. Have a knife run into the pack. Then perform the SLIP CHANGE (Lesson 9). In this way you get the selected card to the top of the bottom section of the deck. Now slide it off and show it to be the selected card. Then continue with your experiment.

You can readily see the importance of knowing your principles thoroughly for each one may be used in many ways and in many effects.

PRODUCING A CARD FROM A WHOLE ORANGE

This is a very effective magical experiment. The beauty of it is that it can be worked under difficult conditions and will puzzle even the closest watcher who looks for suspicious moves.

EFFECT:

An orange is given out for examination and is then held by a spectator during the experiment. Performer has a card selected from a deck by a spectator, who then tears it into a number of pieces. Magician wraps torn pieces in a handkerchief, retaining one corner which is given to spectator. Another member of audience is given the handkerchief and is convinced that he holds the torn pieces of the card in it. Magician jerks the handkerchief and the pieces vanish. The orange is then cut open and there inside of the orange is found the card, completely restored except for the corner which the spectator holds. This corner is found to fit the card.

PARAPHERNALIA:

- 1--Two decks of cards, exactly alike.
- 2--A large orange.
- 3--A knife.
- 4--A prepared pocket handkerchief.
- 5--A tube of glue.
- 6--A sharp pencil.

To Prepare:

Select a card which you intend to use in the effect -- say, the Queen of Hearts. Remove this card from both decks. You may then put one deck aside as you will not need it again.



FIG. 5

The Card:

Take one of the Queens and tear a corner carefully from the card. Figure 5.

Place this corner in your lower right-hand vest pocket or some other place which you can get at easily. Do not carry it around too long for it may get soiled and mused in your pocket.



FIG. 6

Roll the card up as tightly as possible. Figure 6.

★ PIP

The Orange:

Take your orange and carefully remove the little pip at its top. Figure 7.



FIG. 7

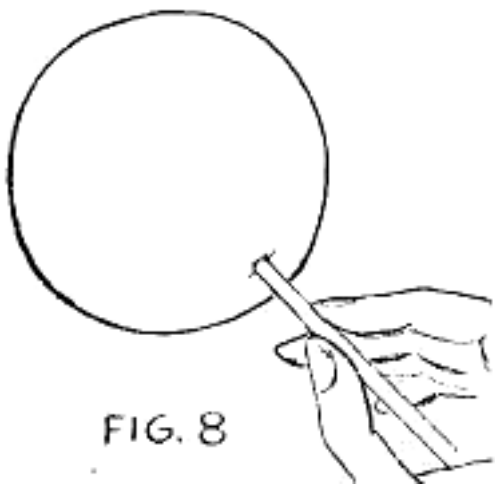


FIG. 8

Push the pencil into the orange where the pip was, making a hole the depth of the card. Be very careful not to break the skin of the orange any more than necessary while inserting the pencil. Figure 8.

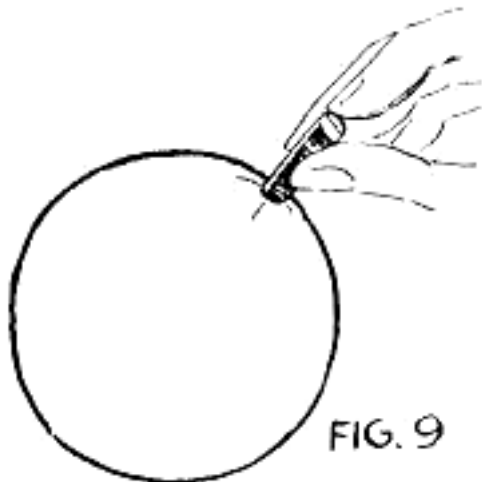
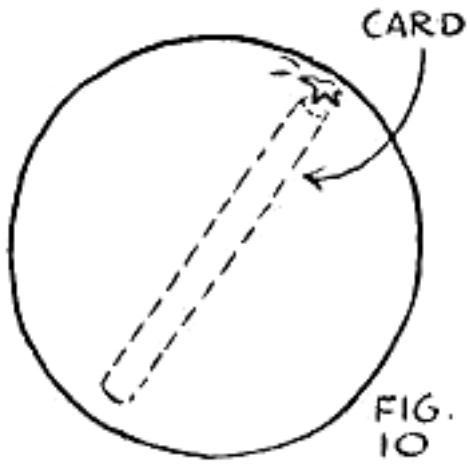


FIG. 9

Remove the pencil and into the hole push the rolled up Queen well into the orange so that it does not show. There is just a little star-shaped opening which will press together easily. Figure 9.



Drop a bit of glue into the opening in the orange and then replace the little pip. Let it dry thoroughly. If this is done properly the keenest eye cannot detect that the orange has been tampered with. Figure 10.

(14-4)

It is surprising how little the skin need be disturbed to get a tightly rolled card into an orange. If there are any slits in the skin caused by pushing the card in, the pip will cover them.

The Torn Card Handkerchief:

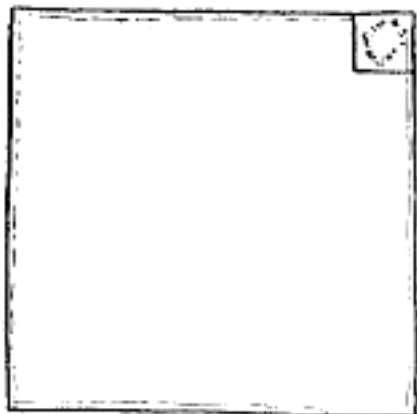


FIG. 11

Take any card from the deck you have placed aside and tear it into eight pieces. Sew these pieces into one corner of a heavy white handkerchief, using another piece of white cloth to cover them and form a pocket. Sew all around the edges of this little pocket so that there is no danger of pieces of the card falling out. Figure 11.

Place the handkerchief in your pocket or have it nearby ready for the effect.

Place the other QUEEN OF HEARTS on top of the deck of cards from which the first Queen was removed -- and you are ready.

To Perform:

Corner of card is in lower right-hand vest pocket, handkerchief in coat or trousers' pocket, and deck of cards, knife, and orange on table nearby.

Pick up the orange.

"I will ask you, sir, to hold this orange for me. You might just look it over carefully to see that it is an orange and pass it around to a friend or two who might like to see it at close view. Please don't eat it - at least, not just yet. After such a critical examination which you have given it, you might hold it up so that the audience can watch it all the time."

Pick up deck of cards and remove from case. You may give them a riffle shuffle, but be sure to allow the Queen to remain on top. (False Shuffle) Practice riffle shuffling in your hands without laying the cards down on anything. Or hold the cards against right thigh while riffling. You may also use an ordinary shuffle without disturbing the Queen.

Insert your little finger about halfway down the pack, and do the REGULAR PASS, thus bringing the Queen to the middle of the deck. Keep two sections of deck JOGGED so that you can easily keep track of the Queen.

"And you, Madam, will you just select any one of these cards."

FORCE the QUEEN OF HEARTS.

"Show it to a friend or two and remember it. Better yet, tear the card in two."

Turn slightly to right and place deck on table with left hand. At same time, reach into vest pocket with right hand and remove the corner of card which you have there. Finger palm it (Lesson 1)

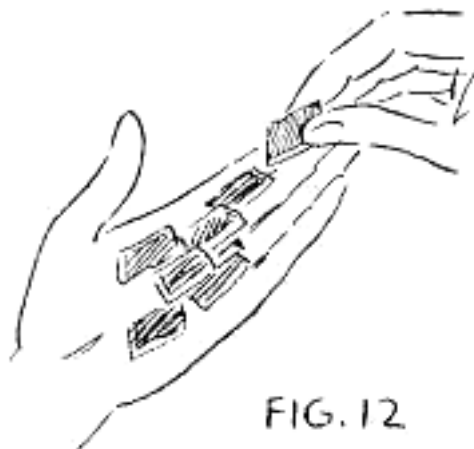
"Place the two pieces together and tear in half again. Place them all together and tear again."

The card is now in eight pieces.

"I will take the pieces."

Take pieces with left hand and place them on left palm. With right hand spread pieces out and then let the corner of card which you have finger palmed drop onto palm with other pieces. Then hold right hand up a little so that audience can see empty palm.

"Remember your card. To be sure that you will remember it, perhaps you had better keep a piece of the card."



Finger two or three pieces of the card and then pick up the torn corner that you placed in your palm. Make it appear, of course, that it doesn't make any difference which piece you pick up. Figure 12.

"This will be fine. Just keep this corner. It has the index of the Queen of Hearts."

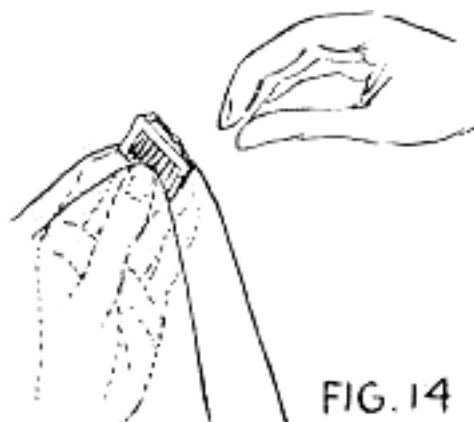
Give corner to spectator who selected card. She thinks that it is a corner of the card she tore up and is not aware that it is a corner of another Queen of Hearts.



Transfer pieces to right hand, holding them close together with tips of right fingers. Figure 13.

Pick up prepared handkerchief with left hand.

"For the time being, I will just place the pieces of the card in this handkerchief and give them to this gentleman to hold."



Spread the handkerchief over your left palm. Keep the faked corner nearest you and hidden from audience. Place the pieces of the card in center of handkerchief and grip them tightly through the handkerchief with the thumb and fingers of left hand. Figure 14.



STUDY THESE IMPORTANT MOVES CAREFULLY.

Pick up the fake corner between the third and fourth fingers of right hand and bring it up in back of and just a little below the torn pieces. Grasp torn pieces between the thumb and first and second fingers of right hand. Figure 15.

With left hand throw handkerchief completely over right hand. It appears to the audience that you have merely taken torn pieces in right finger tips and have thrown the handkerchief over them.



FIG.16

With left fingers take hold of the pieces in the fake corner of handkerchief through the handkerchief. Figure 16.



FIG.17

THE THUMB PALM:

With right hand still under handkerchief, you Thumb Palm the torn pieces. Curve the fingers of right hand downward and place the pieces at base of thumb. Hold them tightly in place by pressing thumb against base of first finger. Straighten first and second fingers and you have accomplished the Thumb Palm. Figure 17.



FIG.18

Practice this move until you can do it easily and perfectly. Practice it first without the handkerchief, then with it.

Be careful to hold pieces of card exposed to palm of hand, but gripped only by the edges so that they do not show between thumb and first finger when back of hand is toward audience. Figure 18.

Practice the THUMB PALM with a half dollar. It is an important move in coin and thimble work which comes later in the course, and you should master it now.

To spectator to whom you are going to give handkerchief with fake corner containing torn pieces, you then say:

"I will just leave these torn pieces in your care."

Remove right hand from handkerchief. Be careful not to expose pieces that are thumb palmed. With left hand give handkerchief to spectator and have him hold the pieces in the fake corner which are now in the center of the handkerchief. He thinks, of course, that he is holding the pieces of the selected card.

"Hold them tightly. You can feel them all right? Just be sure you have them and do not let them get away. Now, I need a knife."

Reach into right coat pocket for knife, and as you do so, leave the pieces of card there. Bring out pocket knife. If you are using another kind of knife and have it on the table, say:

"Oh, here is one on the table that will do."

The audience thinks that you started to look for a knife in your pocket and then just happened to discover one over on the table.

In Magic you can rid of many articles by placing your hand in your pocket, apparently looking for some object.

Hold knife in right hand and use it as a pointer in explaining what you are going to do.

"When the magicians perform this magical experiment in China they do it differently from the way we do it here. There is quite a bit of difference between the psychology of the Oriental and the Occidental or Western World. Perhaps you would like to have me perform this in Chinese style. Very well. When I perform it according to our custom, I never tell what I am going to do. The Chinaman, however, takes special pains to tell you just what is going to happen. He wants you to be sure that you know it will happen and then he convinces you that it has really happened. Now then, what I intend to do is to cause the torn pieces of card to fly suddenly from the gentleman's fingers here and jump over into the orange which the gentleman here is holding."



FIG. 19

Hold knife in left hand. Grasp a corner of the handkerchief which the spectator is holding. Turn to man holding the orange and say: Figure 19.

"You are holding the orange tightly, are you, sir? (To other spectator.) And you still have the torn pieces in your fingers? All right. (To audience.) Keep one eye on the orange, one eye on the torn pieces, and one eye on me."

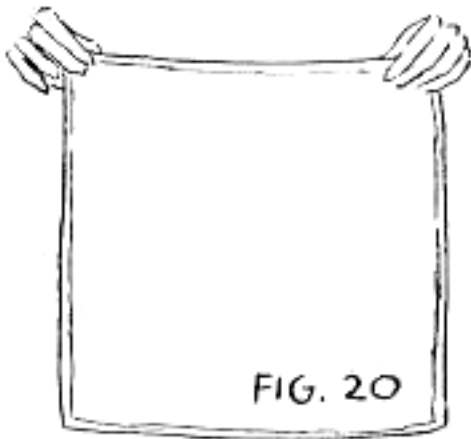


FIG. 20

Jerk handkerchief quickly from spectator's hand. Then open handkerchief and run fingers along one edge so that you can hold it up and show it empty. Turn it quickly and show other side, then take handkerchief by a corner and let it drop again. If you can get fake corner easily into one of your hands while showing handkerchief, so much the better. If you cannot, however, make your moves quickly and the audience will not detect it. Figure 20. Or you can place handkerchief aside immediately after jerking it from spectator's hands.

"Gone. Away they go."

Turn to left and with left hand gesture toward audience.

Place handkerchief in pocket or lay it aside on table.

"Now, if you will let me have the orange please."



FIG. 21

Take orange in left hand and hold it so that audience can see it. Revolve it to show all sides and prove that it is just an ordinary orange. Figure 21.

While doing this and while performing the rest of the experiment, hold your hands so that audience can see at all times that you have nothing concealed. They will be looking for a concealed card in your hands which they expect you to get into the orange somehow.

You must convince them by your actions, not words, that you have no card concealed in your hands.

You are now working up to your CLIMAX and you must SELL your effect to the limit. You are a magical salesman and you are about to sell the idea that the selected card really got into the orange by magical means.

If you are playing in vaudeville or performing where music is available, this is the cue for the orchestra to play. I shall discuss the use of music in snapping up climaxes in detail later in the course.

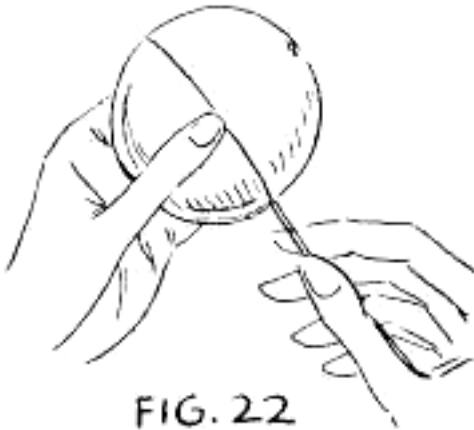


FIG. 22

With orange held in left hand, pip upwards, and knife in right hand, cut orange around the middle into two pieces. Figure 22.



FIG. 23

When orange is completely cut through, place knife down without taking your eyes off the orange. Carefully lift up top half of the orange so that it frees itself from the card and leaves card in lower half. Figure 23.

Focus your attention on the cut orange and card. Hold your audience tense and full of expectancy. You are about to expose the card and this is the great climax of your effect.

Lay upper half of orange on table, keeping your eyes on the card all the time. Remove card from lower half of orange with right hand. Place second half on table with left. KEEP CARD ALWAYS IN AUDIENCE'S SIGHT AND DO NOT TAKE YOUR EYES OFF IT, until orange is on table. Then look at audience.

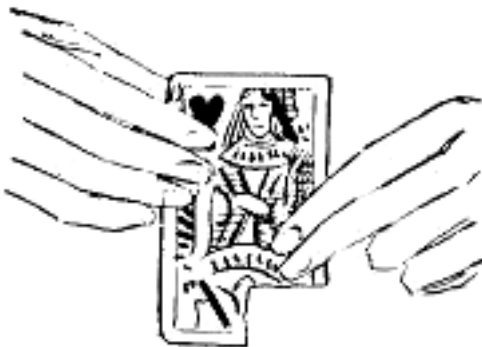


FIG. 24

Unroll card and flatten it out. Figure 24.

"THE QUEEN OF HEARTS. Fully restored by the orange juice -- that is, except for this corner, which the lady here is holding."

Walk up to spectator holding corner of card.

"Will you, madam, please take this card, place the corner against it, and see whether it fits?"

The lady does this, and, of course, the corner fits.

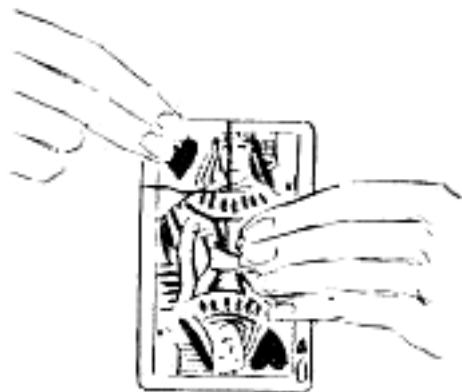


FIG. 25

Then take the card and corner yourself. Hold them up fitted together so that everyone in audience can see them. Figure 25.

Look at audience.

"They fit perfectly."

Bow slightly, and you will get your applause.

"Strange people, these Chinese."

NOTE:

After performance is over, be sure to get rid of upper part of orange so that no one can examine it. Or you may destroy the evidence at the time of performing by breaking the orange into two or three pieces.

THE CARD AND THE BANANA

This is a comedy effect. It fits nicely into a program and it may be used to advantage after the preceding effect. This is an effect which you can tell your audience explains the working of the preceding trick. When you have finished, however, your spectators are more mystified than ever.

If magician is working with a comedy assistant, this may be performed by the assistant while magician goes off stage to prepare for a final effect. Or it may be used just as an excellent piece of magic mixed with a conjurer's troubles of a comedy nature.

EFFECT:

Performer has a banana examined and gives it to spectator to hold. He has a card selected from a deck, causes the card to vanish, and then says he will make it appear in the banana. Spectator peels banana but fails to find the card. Performer is apparently embarrassed and at a loss to know what has happened. He takes an empty envelope from his pocket and places a yellow card therein, upon which he says is written a letter to the Devil. He holds the envelope for a while and then opens it again. The

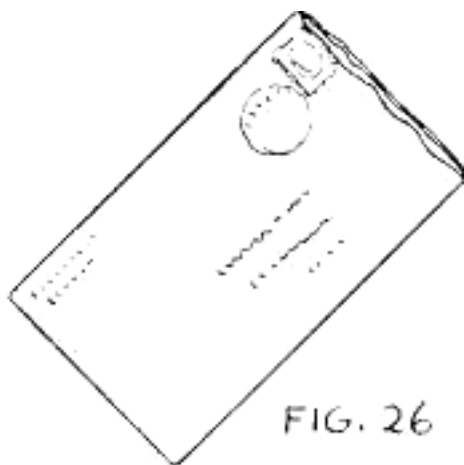
yellow card has vanished and in its place is a red tissue paper letter from the Devil. The Devil gives his reason for failing to help the performer with his trick and returns the card with his letter. Magician asks spectator whether this was the card he selected and learns that it is the wrong card. Upon request, spectator tells the card he selected. Magician then snaps his finger against the card and it changes to the selected card.

PARAPHERNALIA:

- 1 -- A banana.
- 2 -- Deck of cards.
- 3 -- An extra Four of Hearts.
- 4 -- Five Court Cards from the deck.
- 5 -- A double envelope.
- 6 -- Yellow card with writing on it (2 1/2 x 4 inches).
- 7 -- A piece of red tissue paper (9 x 12 inches).

SECRET AND PATTERN:

To Prepare:



Have a double envelope prepared. (Lesson 8.) Seal flap of envelope down tight. Then tear off end just as you would do in opening a letter. This gives you a new form for using the double envelope. You will note that envelope looks like an ordinary one. Only you know that it has a middle partition which can be held against either side so that envelope may be shown to be apparently empty on either side. Figure 26.



Fix up the piece of red tissue paper to look like a letter from the Devil. With water color or black ink, make a letter-head which can readily be seen by the audience. Under this write the special message, which may be something especially fitted for the occasion or something general which you may use at any time, changing it to suit the occasion as you read it. Figure 27.

Your message may read something like this:

My dear (your name):

Sorry I had to disappoint you by not causing the selected card to appear in the banana, but because of the shortage of pineapples in Greenland it was impossible for me to help you at this time.

I am, however, returning the selected card to you. Regards to Mr..... and the rest of the boys.

Your sincere friend,

THE DEVIL.

Fold this red tissue very carefully, two folds each way to make it about 3 x 4 inches. Push this letter well down to closed end of envelope so that it is hidden.

Take 5 Court Cards, Jacks and Kings, from the deck and place them on top. Then remove the Four of Hearts and place it on top of the Court Cards for Forcing.

Take the extra Four of Hearts which you need from the extra pack which we used in the first effect of this lesson. Also take an extra Two of Hearts or any heart card.



FALSE PIP:

With sharp scissors carefully cut out a heart pip. On the back of it put a small piece of magician's wax. (You have a box of it in your outfit) and fasten pip in the center of the Four of Hearts card to make it look like a Five of Hearts. You may paste the pip on in another way also. Rub it on a wet cake of soap and stick it on the card, letting it dry on thoroughly. Either method is good. Figure 28.

Place the prepared card in the envelope with the red tissue paper letter, both on the same side of the middle partition. Place envelope, open end upward, in inner coat pocket on right side.

If you prepare your envelope to look like one which you received through the mails, your effect will be even better. Put a canceled stamp on, your name and address. I often have a real letter in the envelope on the side opposite the red tissue letter and the card. When I take the envelope from my pocket, I pull out the letter and discard it. It appears to the audience that I just took an envelope at random from my pocket and they suspect nothing unusual about it. Little angles of working like this give the NATURAL touch to magic.

To Perform:

Prepared envelope is in pocket, and banana and cards are on table.

If using this effect to follow the preceding experiment in this lesson, you can start your patter in this way:

"I shall explain just how the card disappeared from the gentleman's hand and got over into the orange. First, I must have a BANANA."

Pick up banana.

Or if you are using this experiment without the Card Production from the Orange, you can begin in this way:

"In far-away Bermuda, many miles from Shanghai, lived an old Oriental conjurer who performed an odd effect called 'The Mystery of Three Oranges.' To perform this odd mystery you must first have a BANANA."

Pick up the banana.

"Because of the banana, the effect is called 'The Mystery of Three Oranges.' I shall ask my good friend here to act as guardian over this banana -- to examine it carefully and then to hold it up so that all may see it."

Give banana to spectator.

Pick up deck of cards. The Four of Hearts is on top. Fan cards to show that it is a regular deck.

Insert little finger at about the middle of deck and make the REGULAR PASS, thus bringing the Four of Hearts to the middle. Make the JOG to keep track of this card.

To another spectator:

"Kindly select one of the cards."

FORCE the Four of Hearts.

"Thank you. Look at the card, remember it, and if you care to, show it to a few people around you."

Count (but not aloud) the five Court Cards from the top of the deck. Place the deck on table.

Fan the cards in your right hand. Turn your right side toward audience so that your right hand is over at the left side.

"These five cards are called the Five Wise Men of Bermuda. Will you, please, place the card you selected among the Five Wise Men of Bermuda?"

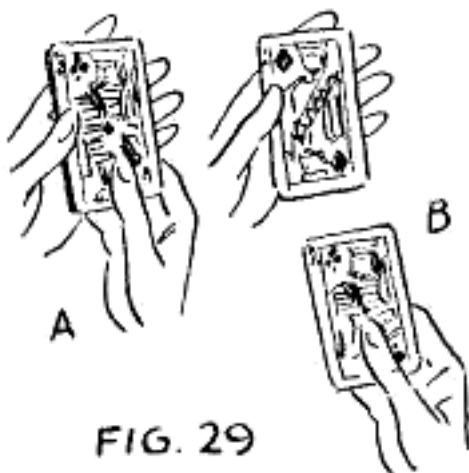
Hold the five cards out fan shape, faces up, and have spectator place the card in with the rest, also face up.

Separate cards into two parts with selected card on the bottom of right-hand cards. Then place cards in left hand on top of the others. This brings the selected card on the bottom of the little pack of cards. (Same moves as in Lesson 9, Figures 23 and 24.)

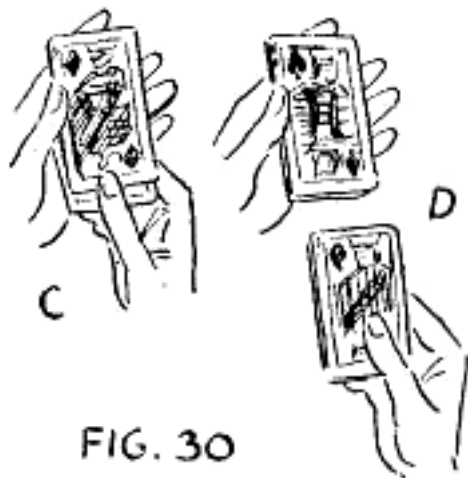
Square up cards and hold them in left hand, faces toward audience.

"The card was the Four of Hearts, I believe. A Four Spot among five wise men."

Hold cards in left hand. Figure 29, A.

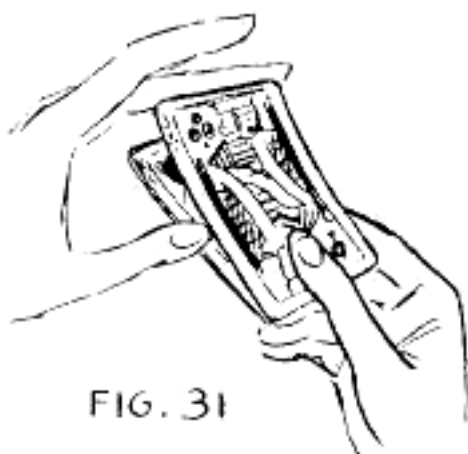


Place fingers of right hand in back of cards and thumb in front. Figure 29, B.



With right hand pull down first card, holding it between thumb and first and second fingers. Now reach up again. Allow this first card to come behind the rest in the left hand, and then pull down the next card. Continue in the same way to count two more cards. Fig. 30. As you pull down each card, say:

"One wise man -- two wise men -- three wise men -- four wise men..."



When counting the fifth card, take the last two -- a court card and the Four of Hearts -- as one. As you put it on the rest of the cards that have been counted, grip it with right thumb. Bend upper edge forward a little with third finger of left hand. When it is in place, remove finger and let card snap down on the others. This snap is used to show that it is one card. (This is the SELF-CONTAINED CARD VANISH: Lesson 12, Figure 30.) Figure 31.

"Five wise men -- but no Four of Hearts."

Oh, where is my wandering card tonight?

Hunting bananas in the bright moonlight.

From college to a banana stand. Please, sir, peel the banana and break it apart, and you will find the Four of Hearts."

Lay cards down on table.

Turn to spectator and say,

"Now, if you will please give me! the card...."

Of course, there will be no card forthcoming, for there is no card in the banana.

"No card? The card isn't in the banana? What did you do, hide it? I guess the joke is on me. Oh, well, never mind."

Reach into inside coat pocket and remove prepared double envelope. Take out the letter you have inside and put it down. It appears that you have an ordinary envelope from which you merely discarded the letter so that you could use it. Do not disturb the Devil's letter and card in the other section of the envelope.

"That is the first time I ever had that effect go wrong. I shall drop a card to the Devil and see what is the matter."

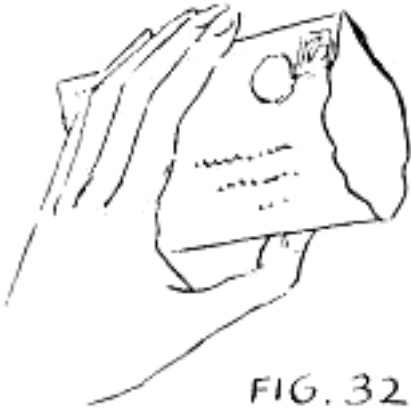


FIG. 32

Take yellow card from pocket. Open envelope with tips of right fingers, pushing middle partition over against Devil's letter so that it is concealed. Bulge the envelope open and show it empty. Place yellow card therein. Figure 32.

Make it evident without saying anything that the envelope is empty and that only the yellow card is going into it.

"This card contains a special message when things go wrong. I'll just mail it to His Royal Highness."

Hold envelope in right hand with the open end up.

"Ah, we have an answer already."

Open envelope, this time pushing partition over against yellow card to conceal it and to expose the red tissue paper letter.

Reach in and remove the Devil's letter and the prepared card. Show envelope empty to prove that yellow card has disappeared. Drop envelope on table, opening to rear.

Open the tissue paper letter, letting the audience see the letter-head from the Devil.

"A letter from the Devil."

'My dear (your name):

Sorry I had to disappoint you, (etc.)'"

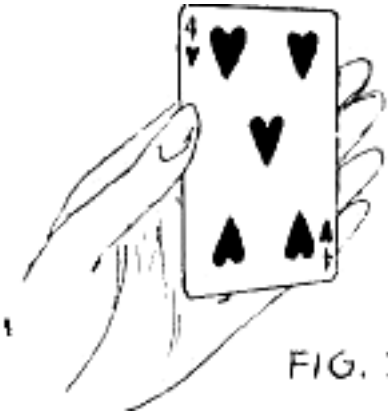


FIG. 33

You can put a great deal of humor into the letter by putting some local touches in it which will strike home with the audience.

"Well, that's that. Anyway, the card came back."

Place Devil's letter on table.

Hold the card up so that all can see it. Figure 33

"That was your card, was it not -- the Five of Hearts?"

Spectator, of course, denies it.

"It was the Four of Hearts? Oh, well -- what's a spot between friends?"



With second finger of right hand, snap off the center pip which is pasted on with wax or soap. Figure 34.

Be sure to hold the card so that all can see you snap the pip off.

This is the CLIMAX of your effect.

Herein is involved a feature of Showmanship which sometimes means great success with an effect. It is used when a performer encounters an unexpected difficulty and works his way out to a satisfactory ending.

In vaudeville acrobats or jugglers will sometimes fail on a trick on purpose to bring home to the audience the extreme difficulty of performing the trick. Then when they finish it right, they are greeted with an outburst of applause.

All the little features of Showmanship must be studied carefully and must be learned through experience to get from an effect the best that is in it.

* * * * *

THE BEWITCHED BANANA

Another comedy effect with fruit and cards which makes a hit. The beauty of this experiment is that in the preparation for it you accomplish the effect so that you may work very close to your spectators without danger of being detected. An excellent effect for parlor, club, or stage work.

EFFECT:

A banana is passed out for examination and given to a spectator to hold. From a cloth bag containing little cards numbered one to ten, another spectator draws a number. Performer peels the banana and it is found that the Inside of the banana has cut itself into the same number of pieces that the number drawn calls for.

PARAPHERNALIA:

- 1--A banana.
- 2--A darning needle or piece of wire.
- 3--A prepared cloth bag.

4--Ten small cards, 1 1/4 inches square, numbered from one to ten.

5--Ten small cards, each marked Number Four.

6--A dagger or knife.

7--A plate for banana.

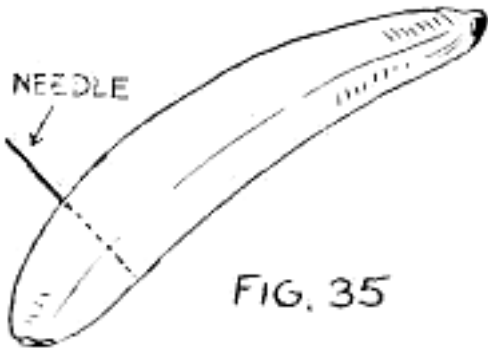
SECRET AND PATTERN:

To Prepare:

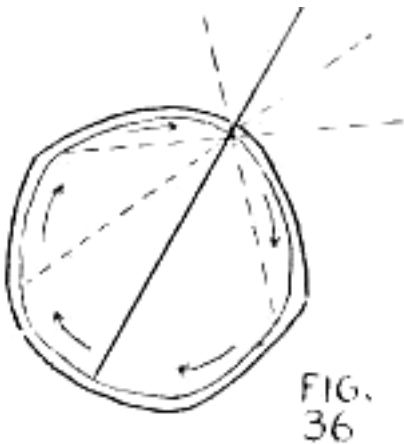
The Banana:

I usually have the banana fall apart into four pieces. You may decide on any number you want and prepare the banana accordingly.

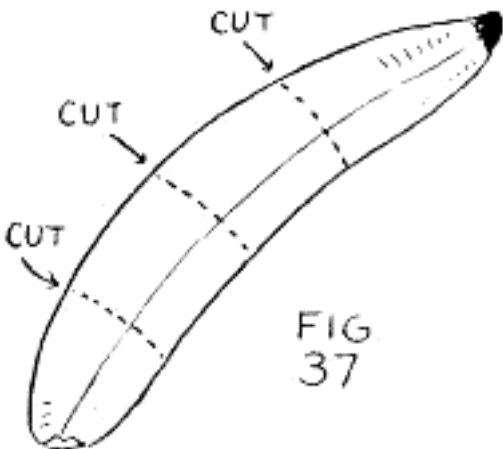
To cut the banana inside the skin without noticeably affecting the skin is very easy. The banana is passed for close inspection after it is prepared and the spectators cannot detect anything unusual about it.



A short time before your performance, take a darning needle. (In emergency, you may use a piece of wire or a tooth pick.) Push the needle into the banana about one-fourth its length from one of the ends. Figure 35.



Move part of needle in banana from side to side carefully so as not to split skin but just the fruit. Make just one hole in the skin but push the needle from side to side in cutting the banana. Figure 36.

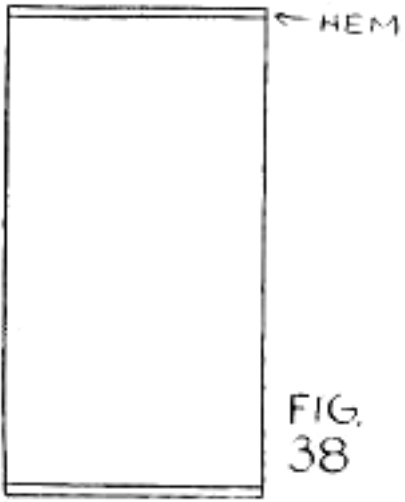


Push the needle in again through the middle of the banana, cutting a second section inside of the skin. Then in the same way cut through the fruit again one-fourth the length from the other end. The banana is now cut into four pieces inside of the skin and you have made only three small holes in the skin which are not noticeable upon the closest examination by the uninitiated. Figure 37.

Your effect is already accomplished before you start the trick and you can work this amazing experiment with confidence.

Cloth Changing Bag:

This is a small piece of paraphernalia which has many uses in Magic. With it you can make small objects appear, disappear, and change into something else.



Take a piece of dark, rather heavy cloth, about 8 1/2 x 4 inches. Fold over twice and sew down carefully and neatly the two narrow edges, making a quarter-inch hem on each. Figure 38.

(14-17)

FIG.
38



FIG. 39

Take another piece of the same material, 3 3/4 x 4 inches. Lay one of the 4-inch edges just below the upper hem of the larger piece. This edge should be the selvage so that it will not unravel. Now fold larger piece of cloth under in back of rest of material to make the bottom hem meet the top hem. With sewing machine or needle and thread sew around the sides and bottom of material to make a bag. The two sides of the large piece of cloth are next to each other and the small piece of cloth is outside. Figure 39.

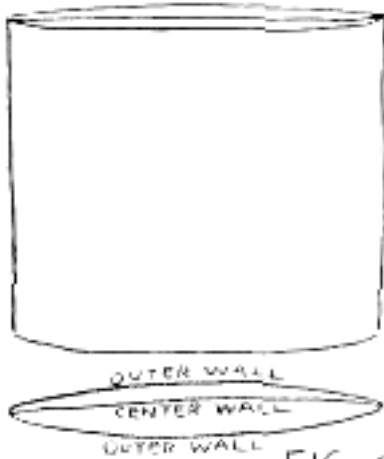


FIG. 40

Turn bag inside out and the hems and seams and inner pocket will come inside. This bag is based on the same principle as the Double Envelope. Figure 40.

The middle partition can be pushed to one side or the other and held in place by putting the fingers inside of the bag to spread it open. Articles may be put into the inner pocket of the bag, and the bag may be turned inside out and shown empty by keeping the fake pocket away from the audience.



FIG. 41

The Cards:

Cut out ten little cards about 1 1/4 inches square. On each, letter the Number 4 rather large so that it can be seen from a distance. Use yellow or white cards and do the lettering in black. Figure 41.

Take ten more of the same kind of cards and letter each from 1 to 10, respectively, in the same way that you did the ten Number 4 cards.

Place the banana on a plate. Place the ten Number 4 cards into the pocket of the cloth bag and put this bag beside the plate. Put the ten numbered cards and a dagger or knife also on the plate.

To Perform:

This experiment works out nicely when you have two boys assist you. Request that two boys come up from the audience. Get their first names. Let us say that Frank is at your left side and Paul at your right. A little back of you and at your left is the table with your paraphernalia for the trick.

"There was a man by the name of Abe and he had a girl by name of Anna. 'Well, well,' said a gentleman as he saw them coming down the street, 'Here come Abe and Anna.' (a banana)."

Pick up banana from plate.

"And that is why, Frank, I use this pineapple. I am going to give it to you to hold, all of it. You see, if I gave part of it to Paul and part to you, it would be a banana split. So, Frank, you are to be chief custodian of the banana. Look it over carefully. Never having seen a banana before, I thought perhaps you might want to have an extra good look."

Give banana to Frank and have him examine it.

"Now, give the report of your inspection to the audience. Bow and say, 'Ladies and gentlemen, I find this fruit to be a bona fide banana.'"

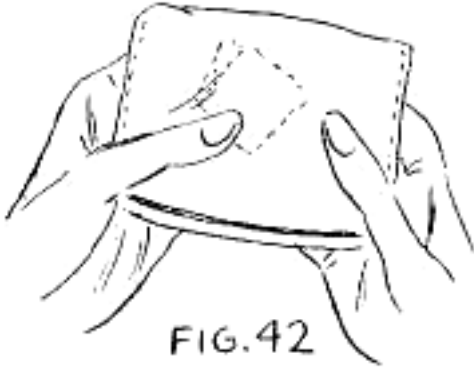
Have the boy repeat this. This is good for a little byplay and comedy touch.

Pick up the numbered cards from plate and the bag.

"Paul, here are ten cards bearing numbers from 1 to 10, each different. Hold out your hand."

Place the cards in his hand one at a time, naming a few of the numbers as you go along to show audience that each is different.

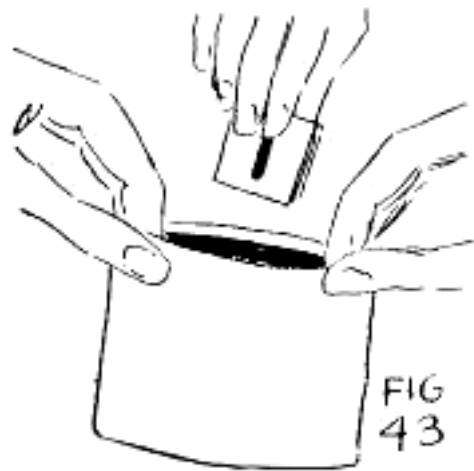
"And we have this little cloth bag."



Turn bag inside out, keeping the cards inside from falling out. Show both sides of the bag. You will have no difficulty in showing it empty and yet keeping the cards secure inside. Figure 42.

Turn bag right side out again.

"Place the ten cards in this bag, please, Paul."



Hold the bag open with the fingers of both hands. This holds the fake partition tight against one side of the bag and conceals the cards already there. Figure 43.

Paul drops cards into opening of the bag.

Take your left fingers from the bag. Let bag hang down from right hand, holding the opening away from audience.

"That's right, Frank, hold on to that banana."

Turn bag towards you as you talk to Frank. Reach into bag again, but this time insert fingers into fake pocket, pushing the middle partition back against the other side of the bag to conceal the cards Paul placed there and to expose the ten cards each having a number 4. It would never occur to anyone that these cards are not the ones which the boy placed in the bag.

"Paul, reach into the bag and take out one card -- any one card that you choose -- any one of the ten numbers."

Paul reaches in and takes out a card.

"What number did you take? FOUR? Oh, yes, that is the number between three and five."

Place bag on table, opening away from audience, or if you desire place it in coat pocket. Pick up knife or dagger from plate.

"Frank, I suppose you have been in Spain. No? Then you have never seen how they slice bananas in Spain. Well, Paul, we'll have to show him. Once upon a time, it wasn't polite in Spain to eat sliced bananas. You were supposed to hold them up whole and take bites, one at a time. Now, the Queen of Spain was giving a grand party, and she was serving bananas whole, like this with their overcoats on. But old King Cornucopia liked his bananas sliced and told her so. The Queen, however, said, 'No, Kingie, it isn't in the etiquette book, and you mustn't eat them sliced until they grow that way.' That gave the King an idea and he called upon his magician, who gave him a knife just like this one and told the King that every time he waved it all the bananas in the room would slice themselves.

"Frank, hold the banana up high. Now, what was the number you selected, Paul? Four? I shall wave the knife four times just like the old King did. Every time I wave, the banana slices itself once. One- two- three - four."

Wave knife four times and count for each wave. Lay knife down on table.

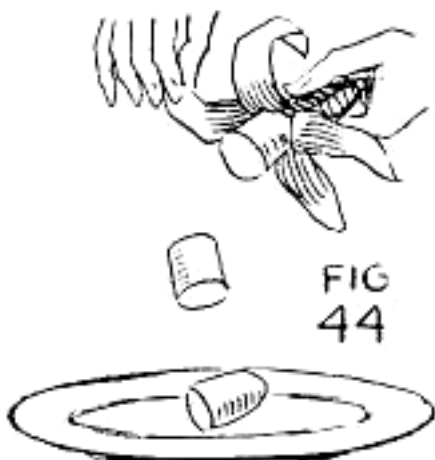
"I will take the banana now."

Take banana from Frank and hold it over the plate on table.

Peel it up to the first cut, jerk hand a little, and let the first piece fall into plate. Then peel to second cut, and continue until you have peeled the whole banana and let the pieces fall one at a time onto the plate. Count each piece as it falls. Figure 44.

"One -- two -- three -- four."

"And ever since, the King had sliced bananas because he said they grew that way."



LESSON 15

In this lesson you learn four more of the finest card effects in the World of Magic. Two of them are given to you by two of the world's greatest magicians.

1 -- The Conjuror's Touch. Performer gives deck of cards to a spectator, who removes a card, shuffles it back into the deck, and then returns the deck to performer. Magician places it in his pocket. Spectator calls out suit of card and magician instantly pulls out a card of like suit from his pocket. Number of card is called out and magician immediately pulls out a card with the same number.

2 -- A Mysterious Discovery. A favorite card effect of PERCY ABBOTT, famous Australian magician.

3 -- "Marvello" -- An experiment of T. NELSON DOWNS,

world famous coin mystifier, in which two selected cards placed in an examined envelope suddenly change places with two other cards in a spectator's hands.

4 -- An odd experiment in which any one of six cards placed in a sealed envelope mysteriously appear in an empty hat.

Step by step the great Magic of Cards is being made known to you. Card magic in its simplicity and its complexity is being laid before you in such a way that it can easily be mastered.

Do not lose sight of the fact that you must first learn the alphabet and pass through the preparatory schools before you can go to college.

Every sleight, every principle which I teach you has its purpose and every effect, simple or difficult, has its place in the great scheme of the whole. Consider nothing which I give you in this course as too simple to spend much time with. What to you now seems simple is something which for me has meant years of study and analysis to perfect and simplify. I have taken some of the most difficult moves and effects in magic and have made them possible for you to learn quickly and easily without the use of cumbersome and expensive apparatus and with none of the old effectiveness lost.

And, on the other hand, consider nothing which I give you too difficult to learn. It takes practice - faithful practice - to become a Master in anything. You are building for a big future and you must lay your foundation strong and solid. With each practice period the difficult moves become easier and before long you know that you have a real accomplishment.

Your ultimate goal is to have your moves become so much a part of your consciousness that you perform them perfectly and automatically. Then as you perform, your thoughts will be concentrated on SHOWMANSHIP and the Mastery of the Art will be yours.

GUIDE TO CARD POSITIONS

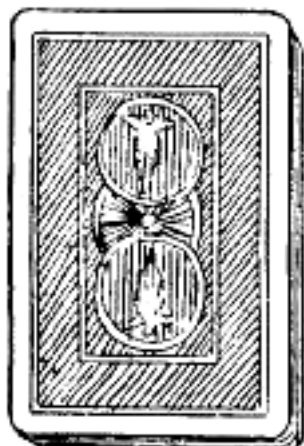
This explanation will be a guide for you in the learning of card sleights and principles. It will make my teaching of them perfectly clear to you. You should memorize these descriptive terms and definitions thoroughly so that when one is mentioned you know instantly what is meant.



"BOTTOM"

FIG. 1

The "Bottom" card of a deck is the one facing outward, the rest of the pack facing in the same direction. Figure 1. The deuce of hearts is the bottom card.



"TOP"

FIG. 2

The "Top" card of a deck is the one with the back outward, the rest of the pack facing in the same direction. Figure 2.

These terms are the conjurer's guide-post only. To the audience if a deck of cards is on the table with the cards facing up, the first card is the top card and the last card is the bottom card, whereas to you the first card is the "Bottom" card and the last card is the "Top" card. Regardless of what position the deck is in, the card facing out is the "Bottom" card and the card with the back out is the "Top" card.

To prevent misunderstanding, in the rest of your lessons I shall put "Bottom" and "Top" in quotation marks to designate the magician's terms.

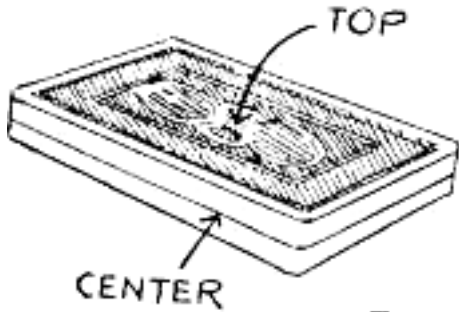


FIG. 3

The CENTER of the deck is midway between "Top" and "Bottom." Figure 3.

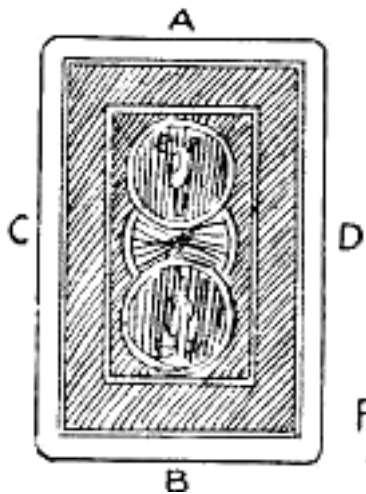


FIG. 4

The edges of a card are designated in this manner, holding the back of card uppermost:

- A -- the upper edge.
- B -- the lower edge.
- C -- the left-hand edge.
- D -- the right-hand edge.

Figure 4.

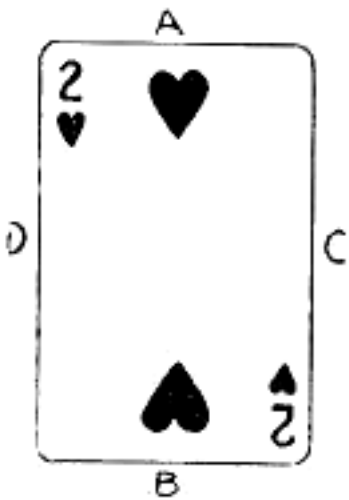


FIG. 5

When card is turned over with face uppermost, A is still the upper edge and B the lower edge. But C is now the right-hand edge, and D is the left-hand edge. Figure 5.

Regardless of what position the card is in, the edges bear the same letters.

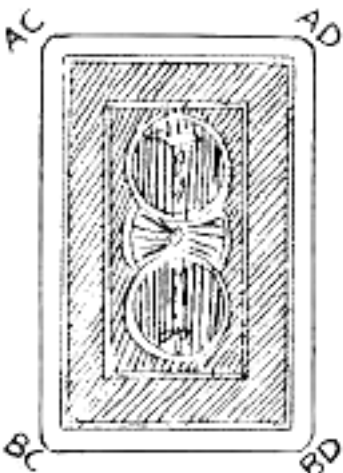


FIG. 6

The corners of the card are designated by a combination of the letters of the two sides forming the corner. With back of card up:

- AC -- upper left corner.
- AD -- upper right corner.
- BC -- lower left corner.
- BD -- lower right corner.

Figure 6.

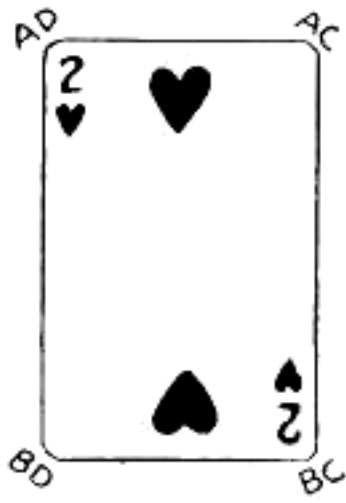


FIG.
7

When face of card is up, corners retain their original letters, merely reversing position. Thus,

AD becomes upper left corner,

AC -- upper right corner,

BD -- lower left corner,

BC -- lower right corner.

Figure 7.

(15-2)

Right Angle Slip Up Palm



FIG. 8

Deck is held in a horizontal position in left hand. Right hand is brought up close to it in a vertical position. Figure 8.

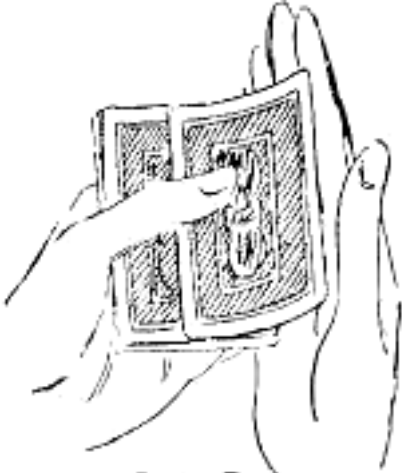


FIG 9

With left thumb push up the top card into the right palm. Figure 9.



FIG 10

Press card securely into right palm with left thumb. The card is now palmed with back of it outward. Figure 10.

This principle of palming is very valuable in some cases when it is advisable or necessary to have the card reversed with back outward instead of face. Practice it until you can do it quickly and easily without being detected. Remember "NOT TO LOOK AT YOUR HANDS."

Oblique Slip Up Palm



FIG. 11

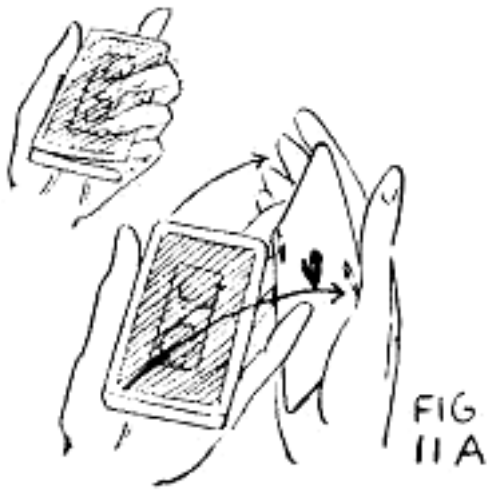
The same principle as the Right Angle Slip Up Palm, except that the deck is held at an oblique angle in the left hand. Figure 11.

Use of this palm is advantageous when you do not want audience to see "Bottom" of deck and their Angle of Visibility is such that they cannot see the card when deck is held at oblique angle.

Right Angle Kick-In Palm

Another form of right angle palm. Deck is held horizontally in left hand and right hand is held vertically beside and a little in front of deck.

If deck is held backs up, the palmed card or cards will be facing outward, and vice versa. Hold deck according to the way in which you desire the cards palmed.



Place little finger of left hand under card or cards to be palmed. Second and third fingers are on top of cards and act as a lever. When you place right hand next to cards, pivot

the cards out with the little finger of left hand, and with the aid of the second and third fingers the cards are "kicked" into the right palm. Figure 11A.

This style of palming is useful in instances when you merely pass the right hand by the deck in a pretended gesture.

(15-3)

similar to the move of transferring cards from packet to packet in the effect, "Cards That Pass in the Night."

BOTTOM TO TOP SHIFTS

Important in sleight of hand with cards is the ability to shift undetectably the "Bottom" card of a deck to the "Top" or vice versa, without disturbing the position of the rest of the cards.

Oblique Slip Up Palm Shift



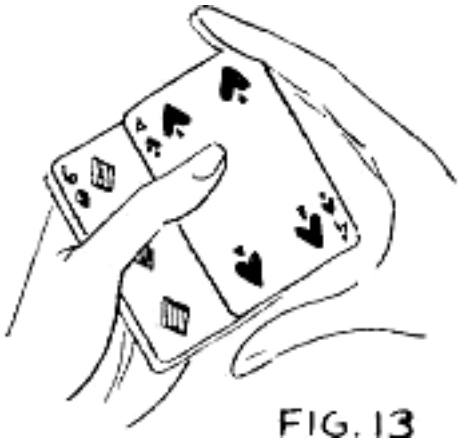
To get "Bottom" card to "Top": Hold deck in left hand with "Bottom" card facing outward in oblique angle away from audience. Perform the Oblique Slip Up Palm, getting "Bottom" card into right palm. Allow right hand to come between left fingers and back of deck. Leave "Bottom" card on "Top" and with the same movement take deck from left hand, holding it between thumb and first and second fingers of right hand. Figure 12.

To the audience it appears that you have merely transferred the deck from the left to the right hand.

To get "Top" card to "Bottom": Practically the same movements as described above. The deck, however, in this case, is held in the left hand with backs up. "Top" card is slipped up, palmed, and shifted to "Bottom" of deck. When deck is transferred to right hand, it should be pivoted around on thumb and first finger of right hand so that backs of cards are toward audience.

The audience does not see face of "Bottom" card and is not aware of shifting and pivoting of deck if you do this properly.

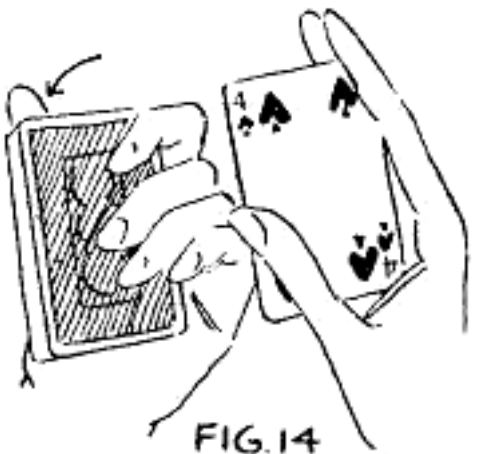
Index Finger Shift

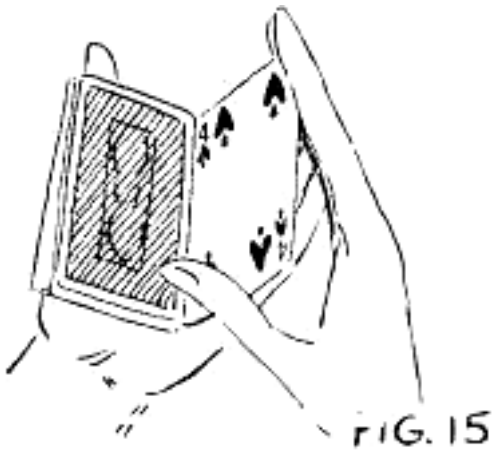


To get "Bottom" card to "Top": Hold deck in a slightly oblique position in left hand. Right hand in vertical position screens cards. With left thumb push "Bottom" card over C edge of deck for about half an inch so that corner AC comes between first joints of index and second fingers of right hand. Figure 13.

Do not open fingers of right hand to receive card and do not push card far enough between fingers to show from back of hand as either one of these two things would bring the attention of the audience to what you are doing. Merely get the card far enough between your fingers to grasp it and hold it securely.

Pull deck away with left hand for a few inches, allowing the cards to fall back against base of left thumb with backs up. Figure 14.





Bring palmed card up to deck in left hand, and place it against deck. Figure 15.



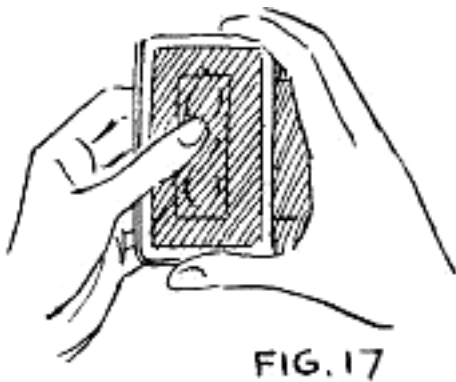
With a continuous movement, as you place "Bottom" card on "Top" of deck, pivot the deck around and into position in right hand. Figure 16.

To the audience it looks as though you just turned the pack over in left hand and flopped it over into your right hand with a flourish.

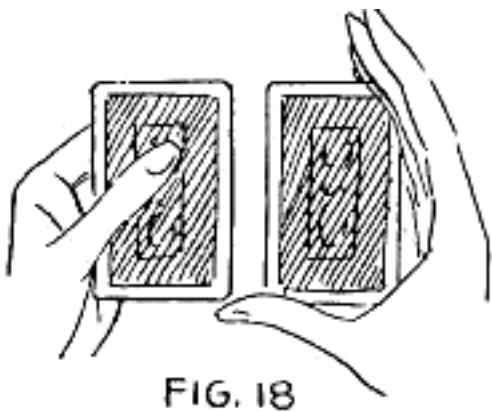
To get "Top" card to "Bottom": Hold deck in left hand with backs of cards up. Repeat movements as described above, but finish with cards in right hand, backs to audience.

Thumb - Little Finger Shift

This is especially adapted for shifting the "Bottom" card to the "Top" of the deck when cards are held backs up in left hand.



Hold pack in left hand, thumb on top of it and fingers under it. Grasp pack at A edge with first and second fingers of right hand and at B edge with thumb of right hand. Figure 17.



With fingers of left hand slide bottom card toward the right so that it is automatically slipped into right hand with AD corner pressed into first joint of little finger and second joint of third finger and BC corner pressed into first joint of thumb. Figure 18.



Draw deck just far enough to left to allow placing of deck below card in right hand. Right hand does not move; the left hand performs the move. The "Bottom" card is now on "Top" of the deck. Finish by bringing up the deck into position between thumb and first and second fingers of right hand with faces of cards toward audience. Figure 19.

THE CONJURER'S TOUCH

EFFECT:

Performer allows spectator to shuffle deck of cards and to remove one card. Remainder of deck is placed in per-

former's right-hand trouser's pocket. Magician then asks what suit the selected card is. When the spectator names it, magician produces a card of the same suit from his pocket. Then the spectator is asked the number of the card and as soon as he gives it, magician produces a card of the same number from his pocket. No matter what the suit and number of the selected card, the magician can produce it immediately from his pocket.

PARAPHERNALIA:

1--A deck of cards.

SECRET AND PATTEN:

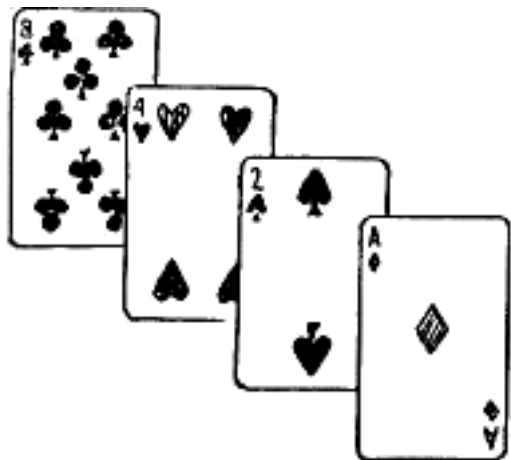


FIG. 20

To Prepare:

This effect requires a prearrangement of four cards which can be done in a moment. Run through the pack and pick out the following cards:

- Eight of Clubs
- Four of Hearts
- Two of Spades
- Ace of Diamonds

Figure 20.

Place these four cards on top of the pack of cards in the order designated, with the Eight of Clubs on top.

Each suit is contained in the four cards and any number from one to thirteen can be made by using each card singly or adding one or more of them together, thus:

If Selected Card Is:	Produce from Pocket:
1	Ace of Diamonds
2	Two of Spades
3	Ace plus Two Spot
4	Four of Hearts
5	Four plus Ace
6	Four plus Two
7	Four plus Two plus Ace
8	Eight of Clubs
9	Eight plus Ace
10	Eight plus Two
Jack	Eight plus Two plus Ace
Queen	Eight plus Four
King	Eight plus Four plus Ace

To Perform:

Hold deck with backs of cards up. Fan it enough so that little finger of left hand can be easily slipped under the four arranged cards.

Palm the four cards in right hand and reach into right trouser's pocket. Push cards up into upper corner of pocket as you did in Lesson 12. Remove handkerchief from pocket and then pull pocket out to show it empty. Replace pocket.

"Will you, please, give the pack a thorough shuffle?"

Give deck to spectator who shuffles it.

"That's what they call the (some small town) shuffle. Now remove any card -- just any card you would like -- but do not show it to me yet. Now give me the deck of cards. I shall place it here in my pocket."

Take deck. Place it in pocket with backs of cards toward audience and in back of cards already there. These four cards are now on top of deck which makes them easy to get at.

"In Magic one develops a very keen sense of touch -- so keen that playing cards can be distinguished by a touch of the fingers. To illustrate: The gentleman here thoroughly shuffled a deck of cards and then selected a card from it. I placed the shuffled deck in my pocket. (To spectator holding card) Will you, please, tell me the suit of your card -- whether it is a Club, Heart, Spade, or Diamond? A SPADE?"

Reach into pocket and produce the third card down, which is the Two of Spades. Show it to the audience so that all can see it.

"A SPADE? And what is the number of the card? An ACE?"

Reach into pocket and bring forth the ACE of Diamonds.

"An ACE!"

Remove deck from pocket and take card from spectator.

NOTE:

Where speed in performance is necessary, as in stage work, performer does not even bother to take up selected card. It is better to step quickly into the next effect.

SUGGESTIONS:

Let us assume that the King of Clubs was the selected card. Reach into pocket and remove the Eight of Clubs -- this gives the suit. Then say, "The King? That's the thirteenth card."

Nod your head and show the Eight in your hand.

"Eight and ..."

Reach into pocket and quickly remove the Four of Hearts.

"Four are twelve and ..."

Reach into pocket quickly again and remove the Ace of Diamonds.

"One are thirteen."

Sometimes it is necessary to count the card in the hand and sometimes not.

I have oftentimes varied the effect by using SEVEN arranged cards instead of four, adding a Jack, Queen, and King. Then when anyone called out a court card as the selected one, it was easy to produce a duplicate.

Again I have worked with thirteen arranged cards, beginning with the Ace and ending with the King. This method, of course, can be used only when you can arrange the cards secretly in advance. In this method of working, you may have the cards in your pocket when you begin the effect.

Any other combination of suits for the Eight, Four, Two, and One cards may be substituted for those which I have given you. The working principle involves these four numbers and the four suits regardless how arranged.

* * * * *

A MYSTERIOUS DISCOVERY

A favorite effect of Percy Abbott, Australian Magician.

EFFECT:

Deck of cards is spread out in a row. Performer turns his back and spectator picks up one to ten cards from one end of row, shuffles them, remembers one, places them on other end of pack, and squares up the whole deck. Magician then spreads cards over the table and shuffles them around with his finger tips. He grasps spectator's wrist and moves his hand above cards. Suddenly he points spectator's hand down on one card. This is found to bear the number of cards which spectator picked up. Then another card is located in the same manner, and this proves to be the card which spectator selected.

PARAPHERNALIA:

1--Deck of cards.

SECRET AND PATTERN:

To Prepare:

Arrange thirteen cards of any suits, starting with the ace and going up to the king (backs up). The effect depends on numbers only, so disregard suits.

Place cards so arranged on top of rest of deck. Backs are up and the King is the top card.

To Perform:

Riffle shuffle the deck, performing a FALSE SHUFFLE so that you do not disturb the 13 arranged cards on top of deck.

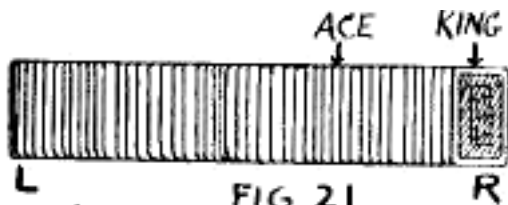


FIG. 21

Spread pack on table for a distance of about 18 inches from end to end. Figure 21.

To spectator:

"When I turn my back. pick up any number of cards that you choose -- from one to ten -- from this end."

Point to end L.

Spectator picks up a few cards from this end. Figure 22.

The arranged cards are all at the other end of deck.

"Have you picked them up? Now shuffle the cards in your hand."

Spectator shuffles cards.

"Square them up and keep the backs toward me. Notice the card that is facing you and remember it. Now just square up the cards on the table. Place the few cards you have in your hand on top of the deck and square them all up."

Spectator squares up cards in his hand, remembers the one facing him. Then he squares up the remainder of the pack and places the cards he picked up on top of the others. All this is done while you have your back turned. Figure 23.

When spectator is through, turn around and pick up the deck of cards.

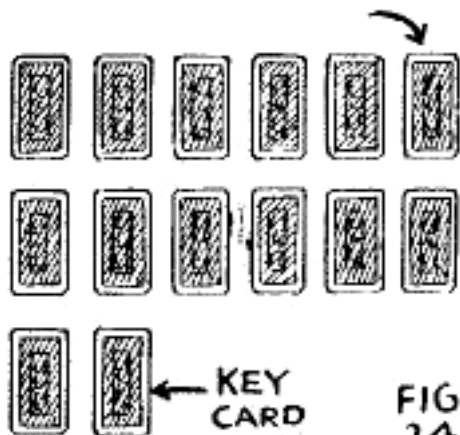
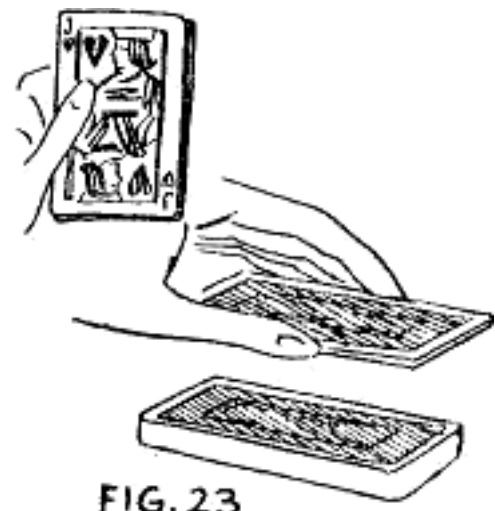
"Let us see whether everyone understands what has been done. I shuffled a pack of cards, spread it out on the table. You picked up a few cards from this end -- (Point to end) I do not know how many. You remembered one of them, then squared up these cards and placed yours on top of them. That is correct, is it not?"

This gives you an opportunity to check up and see whether everything was done right.

Deal cards down on the table one at a time into a row of six, then under this another row of six. Begin laying down a third row, and as you do so, get a glimpse of the second card in this row as you lay it down. This is the 14th Card and is your Key Card. Figure 24.

The number of this 14th card tells you how many cards the spectator transferred from the bottom to the top of the pack and also tells you which card the spectator selected to remember.

Let us assume that the Key Card is a Six of Hearts. Six then is your cue number. The spectator transferred six cards and consequently the sixth card which you laid down is the selected card - this is the last card in the first row.



KEEP SIGHT OF THESE TWO CARDS.

Spread the rest of the cards around everywhere -- just drop them helter skelter but do not fully cover the two Key Cards. You must not lose sight of them.

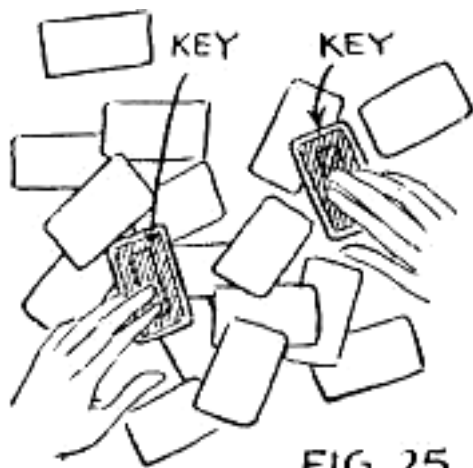


FIG. 25

Place tips of right fingers on one Key Card and tips of left fingers on the other Key Card and shuffle all the cards around to make it appear that you are mixing them up thoroughly. In this way all the cards are mixed up except for the two Key Cards which you have under your fingers. Figure. 25.

Remove your fingers from the cards but REMEMBER WHERE YOU HAVE THE FOURTEENTH CARD AND WHERE YOU HAVE THE SIXTH so that you can spot them instantly.

"As one gentleman remarked. 'It is quite a mixup.'
Sir, have you magnetic hands?"

Have a spectator come around to side of table so that front view will not be obstructed. You must always be careful to see that audience's view is good from every side.



FIG. 26

Grasp gentleman's right arm at the wrist. Figure 26.

"Point your index finger out at the cards while I move your hand around. If you have magnetic fingers, you will attract some cards and repel others."

Move his hand slowly over the cards and finally hold it over the FOURTEENTH card. Hesitate a moment, then move it slightly away, then back again as though you were undecided. Then press his finger down on the card.

Pick up this card and show it.

"A six spot."

To gentleman who transferred cards,

"You transferred six cards from one end of the pack to the other. Correct?"

Take gentleman's hand again and hover over the cards, finally pressing it down on the other Key Card. Lift up the card. It may be any card, but let us assume that it is the Jack of Hearts.

"The Jack of Hearts. That is the card you selected and remembered. Is that right? Correct!"

* * * * *

"MARVELLO"

I am indebted to T. Nelson Downs, world famous coin and card mystifier, for this excellent effect with cards.

EFFECT:

Performer shuffles a deck of cards and asks a spectator to think of any number between 5 and 20 and another spectator to think of any number between 25 and 40. Magician deals the cards faces up on the table, telling each spectator to remember the card as it appears at the number each selected. Performer then asks each spectator what his number is. He counts off the cards one at a time on the table, placing the selected cards aside – for instance, the 18th and 38th. Two cards are then taken from the pack at random and shown and placed in an empty envelope. Performer now takes more cards from the pack and puts with them the two selected cards – these he gives to a spectator to hold. He says that he will cause the cards in the envelope to change places with the selected cards in spectator's hand. These cards are examined and it is found that the selected cards have vanished and the indifferent cards are there. The selected cards are then taken from the envelope.

PARAPHERNALIA:

- 1 -- A deck of cards.
- 2 -- An ordinary envelope.
- 3 -- A small table.

SECRET AND PATTERN:

You will need two people to help you. For convenience we will call them Smith and Jones. Smith should be at left side and Jones at right. Table should be in front of you.

Thoroughly shuffle the deck, preferably giving it a riffle shuffle in your hands.

"You have perhaps noticed, at one time or other, that when you wished to remember a certain thing, if you associated it with some object, you were able to remember it perfectly. Therefore, I am going to ask you two gentlemen to select a card each; and in order to remember the card exactly, I want you to associate the card with a number."

To Smith,

"I shall ask you to think of a number between 5 and 20."

To Jones,

"And you think of a number between 25 and 40. Have you decided upon your numbers? Very well. I will count the cards down on the table one at a time and when I come to your respective numbers, remember the card at that number. If you chose 16, remember the 16th card; if 31, remember the 31st card. Of course, do not let me know your number, as yet, nor the card at that number."

Hold deck, backs of cards up, in left hand and with right hand count them out one at a time on table, faces up.

COUNT ALOUD each card as you lay it down until you have counted the whole deck.

"Do not forget the card or the number."

Pick up deck from table and hold cards in left hand, faces up.

Turn your right side to audience so that you are looking directly at Smith.

"Now, sir, . . . "

As you start to speak to Smith, you transfer the card facing you to the other side of deck. You perform the OBLIQUE SLIP UP SHIFT with the "Bottom to Top" transfer, explained at the beginning of this lesson.

Deck should now be in left hand with backs of cards up. To audience it looks as though you merely turned the deck over.

"Will you please tell me the number you selected -- the number only, not the card?"

Let us assume that he says 18.

"I will count the cards down to your selected card. One, two, three . . . " etc.

Count the cards down one at a time in a pile, this time with card faces down.

"Eighteen -- here is your selected card. I shall place it over here for a moment."

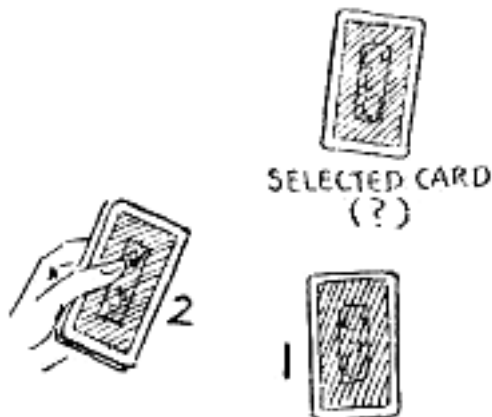


FIG. 27

Place this card aside toward front of table. Do not let anyone see this card. This, of course, is not the selected card. The one chosen by the spectator is now the 19th card in the deck instead of the 18th, since you made the transfer. This card is now the top card of the portion of deck which you hold in left hand. Figure 27.

Turn to Jones at your right and say,

"Will you please mention the number you selected -- the number only?"

Let us say the number is 38.

"Thirty-eight. To continue our count -- Eighteen . . ."

Point to card laid aside and count cards one at a time on the table, MAKING A NEW PILE. The 19th or selected card is the first one in this new pile of cards. Cards are backs up.

Continue to count aloud and when you reach 38, say,

"Thirty-eight. Here is your selected card. I will place it also over here with the first selected card."

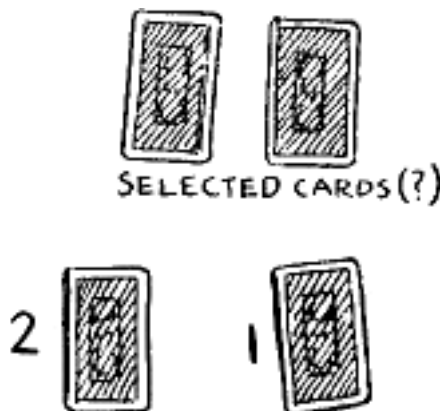


FIG. 28

Place this card near other one which you placed aside. Then put remainder of deck in left hand on the SECOND pile of cards on table. The 39th card is the second selected card and this is now on top of this pile. Figure 28.

You now have ONE SELECTED CARD ON THE BOTTOM AND ONE ON THE TOP OF THE SECOND PILE OF CARDS.

Pick up the second pile of cards from table and hold it in left hand, backs of cards toward audience so that no one gets a glimpse of selected card on bottom.

"I shall cut the pack once."

Hold pack as you would for the REGULAR PASS. Split pack about in the middle at the forward end to allow you to insert the little finger as in the PASS.

Lift front section over and place it back of other section, keeping little finger between the two sections but allowing front of cards to come together as you do when a selected card is replaced in the deck and you keep track of it.

You are really doing a slow PASS but doing it so that everyone can see that a cut is being made.

With right thumb release the bottom card on top packet, withdraw little finger for a moment and let this card fall on top of other selected card on other packet. Then immediately reinsert little finger above the two selected cards.

You now have this arrangement:

Top section of deck.

Little finger.

Two selected cards on top of lower section of deck.

"Cut it again."

Cut it again. This time selected cards come to top of pack. Allow both packets to come together as one now.

"And shuffle."

Riffle shuffle the deck in your hands, performing a FALSE SHUFFLE. Be sure that selected cards are left on top.

With right hand over back, lift up the top THREE cards as one, as explained in the DOUBLE CARD LIFT (Lesson 9, Figures 7, 8).

Show these three cards as one and call out the name of the card exposed. Assume that it is the King of Hearts. Figure 29.

"The King of Hearts."

Then with left thumb slip off the top card of pack in left hand. Show it to audience and call it aloud. Let us say that it is the Seven of Spades. Figure 29.

(15-13)

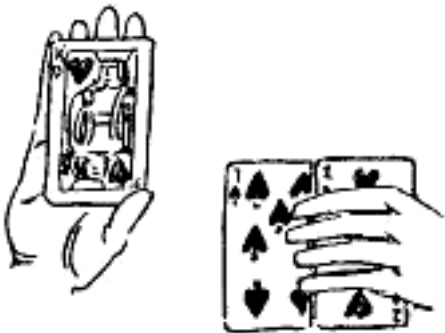


FIG. 29

"The Seven of Spades. I have here just two indifferent cards."

Slide Seven of Spades back onto pack and replace the other three cards on top it.

With left thumb push the two top cards off to right side and remove them with right hand. These are the two selected cards and you must be very careful not to expose the faces of the cards. Audience believes these two cards to be the two indifferent cards which you just showed.

"I shall place them in this envelope."

Place deck on table and pick up envelope with left hand.

Give envelope to Smith at your left.

"First, will you look inside and see that it is empty?"

Take envelope again in left hand and place two cards inside.

"I shall place these two indifferent cards, the King of Hearts and the Seven of Spades, inside."

Seal envelope and give it to Smith to hold.

Pick up about half of the cards of the second pile on table with the King and Seven cards on top. Fan them with right hand, backs of cards up.

"I shall take a few cards and place the two selected cards among them."

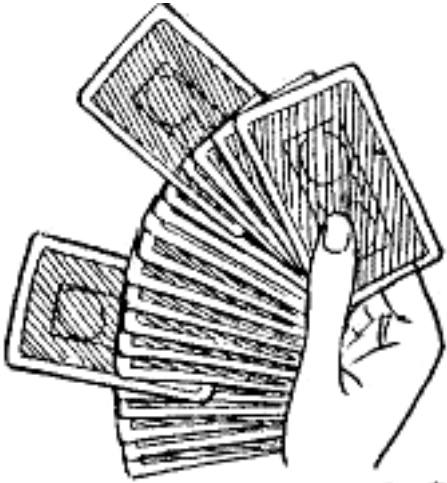


FIG. 30

Pick up the two selected cards. Place them in different parts of the packet which you have fanned in right hand. Audience must not see these two indifferent cards for they think these cards are the selected ones. Figure 30.

"One here and the other there -- and shuffle."

Shuffle cards to mix them up.

"And I shall ask you to hold them tight."

Give this packet to Jones at your right.

"Are you interested in rapid transit? I shall show you a method that has even subways and aeroplanes outdone. I shall cause the two indifferent cards in the envelope to jump suddenly over into your hands, sir (to Jones), and the two selected cards to fly over into the envelope. No sooner said than done. (To Jones) Will you look through the cards in your hand and see if the card is among them?"

Jones looks through cards and, of course, does not find his selected card.

"Run them through for this gentleman (Smith) and let him see whether his card is there. No card? See, they have

passed. Now, see whether the King of Hearts and the Seven of Spades, the two indifferent cards, are there instead."

Gentleman finds the two indifferent cards and shows them to audience.

To Jones,

"Will you please mention your card, sir?"

Let us assume that it is the Five of Diamonds.

"The FIVE OF DIAMONDS."

To Smith,

"And the name of your card? The QUEEN OF CLUBS. Now tear open the envelope and take out the cards."

Smith removes cards from envelope. You take them and show them to audience.

"The Five of Diamonds and the Queen of Clubs."

* * * * *

CARDS, ENVELOPE, AND HAT

EFFECT:

Performer gives shuffled deck to five or six spectators in rotation, having each one select a card. A slip of paper is given to each one on which to write the name of his card. The slips are folded up and placed on a plate. Magician collects cards and seals them into an envelope. A hat is shown empty and placed on table. On it is placed a plate, and on the plate, the envelope is placed. One of the folded papers is selected and the name of the card read. The envelope is opened and it is found that the card named has disappeared from the other selected cards. The plate is then removed from the hat and the missing card is found in the hat.

PARAPHERNALIA:

- 1--A deck of cards.
- 2--Six strips of paper, about 6 inches long and about 1 inch wide.
- 3--A medium sized envelope.
- 4--Two plates, one large enough to cover inside of crown of hat.
- 5--Six sharpened pencils.

To Prepare:

Have paraphernalia ready on table.

To Perform:

Pick up deck of cards. Riffle shuffle it in your hands. Pick up slips of paper and pencils. Give cards to spectator.

"Will you please remove a card, look at it and remember it? Do not show it to me. Then write the name of your card on this slip of paper."

Give spectator a slip of paper and a pencil.

Then pass on to five more spectators and let them remove any cards they choose. Give each a slip of paper and a pencil so that he can write the name of his card on the slip.

Take plate from table. Ask each to fold his slip of paper.

"Please fold the papers up rather small and place them on this plate."

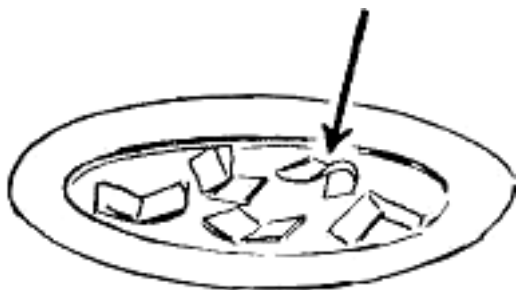


FIG. 31

Pass the plate to each spectator. As each places his slip on it, notice one slip which is folded peculiarly so that it can be recognized even when shuffled about and remember which spectator placed this slip on plate. Figure 31.

Should the papers be folded in the same way, fold a corner of one or twist it in some way. It is easy to fix the slip so that you can find it easily. A little ingenuity on your part will solve the problem. As a rule, however, people fold the papers differently so that there is no difficulty in finding an odd shaped one.

"I shall mix them up a bit."

After papers have been collected, shuffle them about. Be sure you can locate the one you have selected.

Give plate to a spectator to hold.

"Now will you please let me have your cards?"

Collect the cards, placing the card of the person whose slip you selected on top of the others. Cards are backs up.

"And will you, sir, just examine this envelope?"

Give envelope for examination.

"I shall place the cards inside for temporary keeping and seal it."

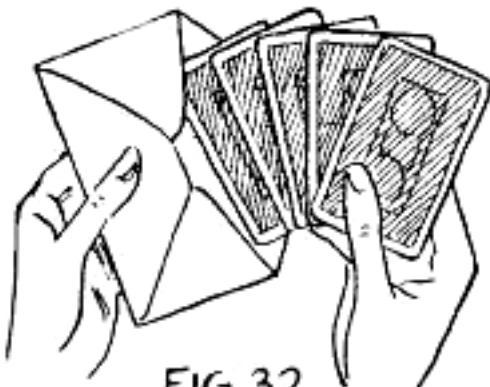


FIG. 32

Hold envelope in left hand and cards fanned out in right hand, faces of cards toward audience. Apparently place all the cards in the envelope. Figure 32.

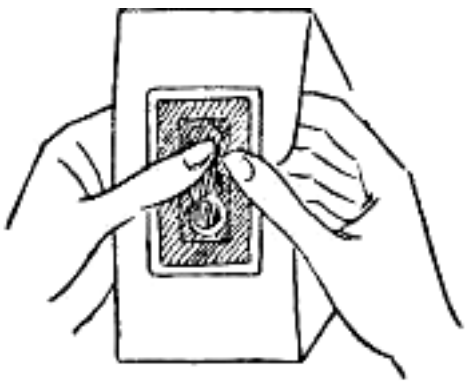


FIG. 33

In reality you put all the cards in but the selected one. This is on top and as you push the cards in, you slide this one over the outside edge of the envelope. This side is, of course, away from audience. Figure 33.

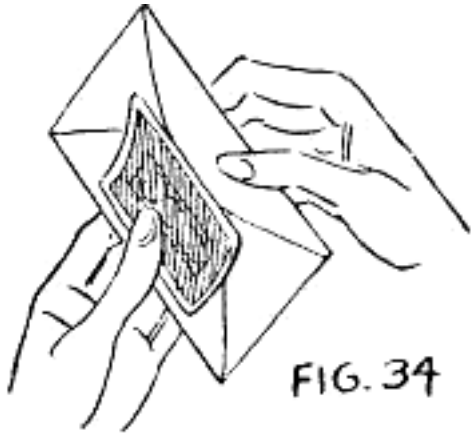


FIG. 34

Seal envelope. You will have no difficulty in doing this if you press down on lower edge of card, thus raising upper edge and giving the flap room to be inserted under it. Fig. 34.

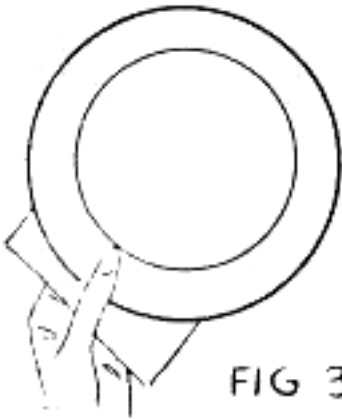


FIG 35

Turn to right and pick up plate from table with right hand. Show both sides and place it in left hand with envelope. Figure 35.



FIG 36

Note that plate is held so that part of envelope shows. With fingers of left hand slip up the card in back of plate and envelope until most of the card is beyond envelope and is against the plate. Figure 36.

Pick up hat from table and show it empty, holding it in right hand. Then place it on table, open end up.

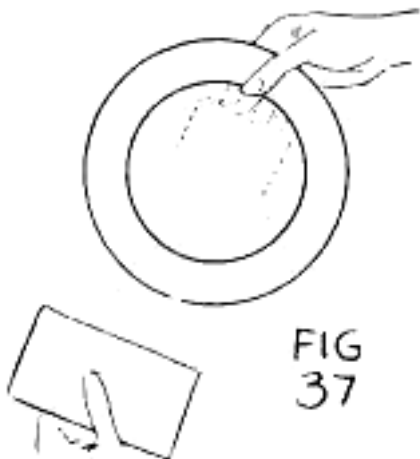
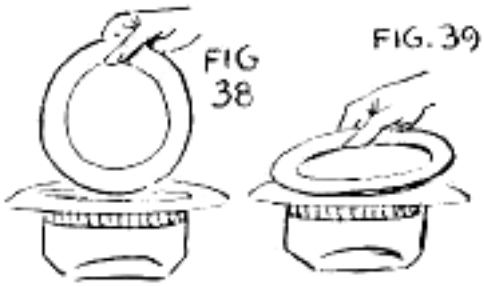
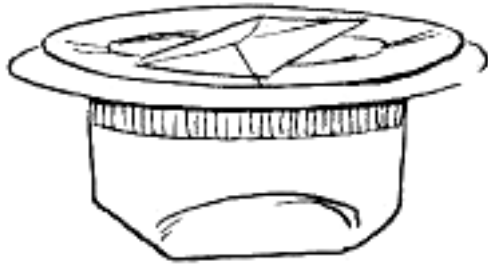


FIG 37

With right hand pick up plate and with it the card which is in back of it. Figure 37.



Place plate over opening of hat, allowing outer edge to touch front side of hat first. Then as you place it down horizontally, let the card fall into the hat. The plate, of course, screens the card from the audience when you put it down in this manner. Figures 38, 39, 40.



Show envelope both sides and drop it on plate. Figure 41.

(15-17)

FIG 41

Go down to spectator holding plate with slips of paper.

"From these six slips of paper we will just select one -- just anyone will do."

Reach over and pick up the slip which you had selected. Do not make it obvious that you intended to take this one. Fumble around a little among the slips and then take this slip.

"Will you please open this slip and read the name of the card written on it?"

Give slip to spectator, who opens it and reads name of card. Let us say that it is the Nine of Clubs.

"The NINE OF CLUBS."

Take up plate with slips of paper and place it on table. Then hand envelope to spectator to open.

"Please tear open the envelope, take out the cards, and give me the Nine of Clubs."

Spectator opens envelope and removes cards but fails to find the Nine of Clubs.

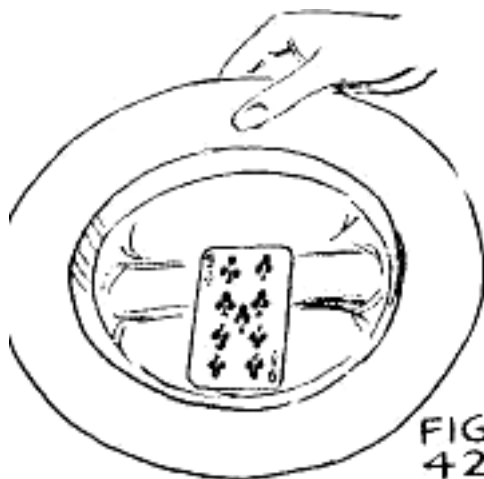
"What! No Nine of Clubs? Who selected the Nine of Clubs?"

Person who selected card answers.

"You, Madam? Thank you."

Pick up cards and envelope and go back to table. Drop them on plate with slips of paper.

Show your right hand both sides casually. Then lift up plate on hat and place it on table.



Grasp hat at rear end of brim, raise it from the table, tilting it forward to show the Nine of Clubs inside. Figure 42.

Show right hand empty, reach into hat and remove card. Show card to audience.

"The Nine of Clubs -- never satisfied to stay at home."

Place hat and card on table.

* * * * *

NOTE:

This experiment permits of variation, depending on where you are performing. I have described it for Parlor or Club work, where an audience is sitting fairly close to you.

It is done on the stage sometimes with a committee of six people, sitting three on each side facing front and within a safe Angle of Visibility.

At times it is more convenient for you to open the envelope yourself. If you do so, call off the cards one at a time and drop them from a height of about a foot onto the plate so that all can see them. The selected card has vanished. To emphasize that you have nothing concealed in the envelope, tear it into four pieces and drop them also onto the plate. Then proceed with finish of experiment.

* * * * *

LESSON 16

This lesson builds up for you more fascinating card effects:

- 1 -- "Tack It" -- interesting card experiment of Ed Reno, prominent magician.
- 2 -- A modern version of the card through the handkerchief experiment.
- 3 -- Another effect in which three selected cards penetrate a handkerchief, one at a time, after the whole pack has been securely wrapped in the handkerchief.

* * * * *

A handwritten signature in cursive script that reads "Harlan Tarbell". The signature is fluid and elegant, with a large, sweeping flourish over the "l" in "Tarbell".

TARBELL SYSTEM, INCORPORATED, Chicago.

(15-19)

And yet they come! -- these fascinating Card Mysteries -- to Intrigue you with their cleverness.

And think! You are now learning effects which the Modern Masters of Magic use in their repertoires. You are learning their secrets and their methods so that you, too, may master these experiments and work for skill to match theirs. Faithful study and earnest practice will bring you to the stage where you, too, can hold audiences spellbound with the display of your wonderful art.

"TACK IT"

An effective version of the famous tacked card mystery by Ed Reno, a Master of the Art.

EFFECT:

Spectator selects a card from a deck, returns it, and it is shuffled thoroughly into the deck. Magician then pretends to show a tack to audience. He places this invisible tack in the center of pack. Rubber bands are placed around the pack and it is thrown at a board. All the cards fall to the floor except the selected card which mysteriously attaches itself by means of the tack to the board.

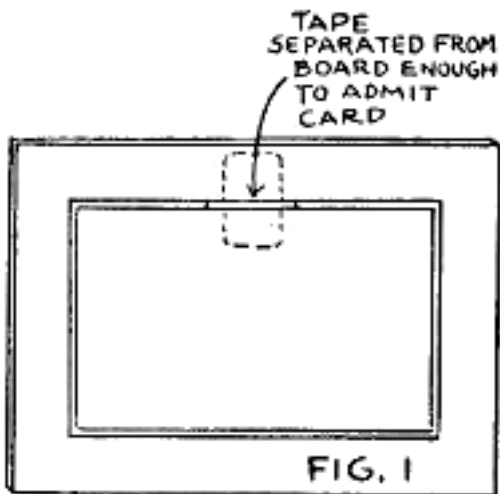
PARAPHERNALIA:

- 1 -- A deck of cards.
- 2 -- An extra card.
- 3 -- A thumb tack or sharp carpet tack.
- 4 -- Two rubber bands.
- 5 -- A soft pine board, about 12 x 16 inches in size. Board should be about 1/4 inch thick. The artist's drawing board makes a suitable board for this experiment.

SECRET AND PATTERN:

To Prepare:

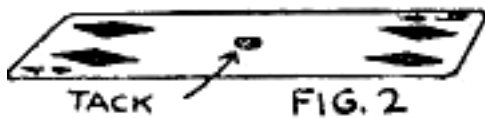
Paint the board any color you choose on both sides. Black is the color generally used.



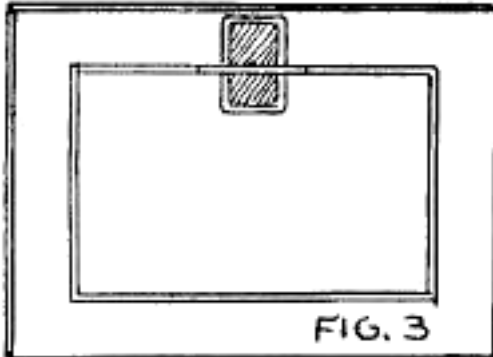
On the back of the board make a border of one-fourth inch elastic tape about two inches from the edges. Glue or tack this border to the board, leaving on one of the long sides a space large enough to permit the insertion of a card.

Figure 1.

If desired, this board may be taped on both sides. To the audience it looks like a decoration, but it serves a much more useful purpose.



Push the thumb tack through the center of the extra card (assuming here that it is the Four of Diamonds). The head of the tack must be on the face of the card and the point at the back. Figure 2.



Place this card under the tape on back of board. Face of card should be against board and tack should be resting on tape. Figure 3.

Place the board on a nearby chair, leaning it up against back of chair, or let it lie on the table.

Run through your pack of cards, pick out the Four of Diamonds and place it on top of the deck in preparation for forcing.

To Perform:

This is an excellent trick in which to use a small boy as an assistant. Request that one come up from audience and, as usual, learn his name. Suppose it is Theodore.

Have the deck of cards in your hands.

"Theodore, you are! about to come in to your own. While the audience isn't looking, I want you to select one of these fifty-two cards."

FORCE the Four of Diamonds. (Lesson 14.)

"Show it to the audience, but do not let me see it."

Turn your back to Theodore while he shows the card to audience. Pick up rubber bands.

"Now take the pack and shuffle your card in among the rest of the cards."

Theodore takes pack, places his card in it, and shuffles it.

"Sort of shuffling along, I should say."

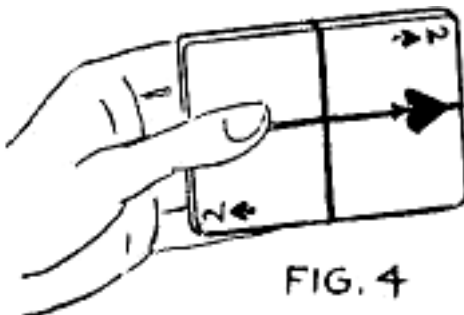
Take pack.

"We shall just place a rubber band around the pack this way."

Place one rubber band around pack the short way.

"And another around the other way."

Place the other band around the cards the long way.



Show cards securely bound with rubber bands. Hold pack in left hand and show both sides. Figure 4.

(16-2)

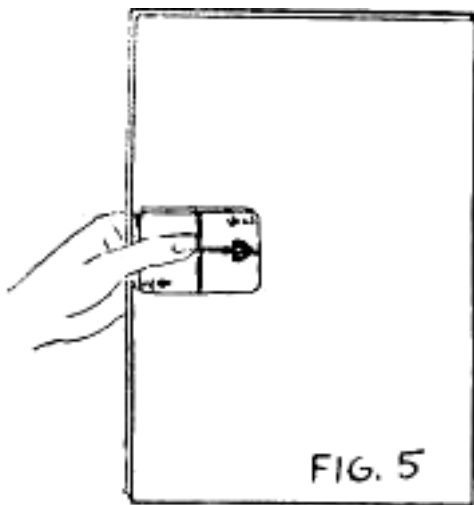


FIG. 5

Walk over to chair or table and pick up board in this manner: Deck of cards held by left thumb on front of board, card with tack on back of board held by left fingers. Figure 5.

"Step over this way, Theodore, a foot or two."

Motion to him with right hand, turning your right side toward audience. This brings your left hand with board and cards away from audience.

Reach over and take board with right hand. The Four of Diamonds with the tack in it is automatically slipped from the back of the board to "top" of the pack. Square this card up with the pack.

"And hold this board. You may hold either side or both, if you like."



FIG. 6

Show both sides of board, then give it to the boy to hold with taped side away from audience. Figure 6.

"Hold it tight so that all your friends can see both you and the board."

Be careful to keep faces of deck of cards toward audience so that they cannot see the detached card at rear.

Now reach into pocket and pretend to bring out a tack held between tip of first finger and thumb of right hand.

"Theodore, this is a tack which I hold here in my hand. Have you ever come into sudden and unexpected contact with one? It is remarkable, isn't it, how a simple tack can find one out? I'll just place this one inside the deck."

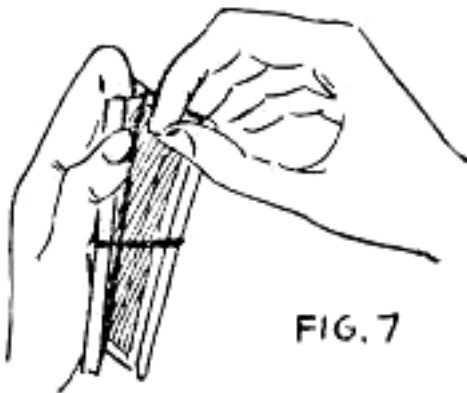


FIG. 7

Open the cards a little about in the center of the pack and pretend to place the tack there. Figure 7.

Allow cards to come together again. Hold deck again facing the audience, in left hand with palm and fingers screening back of deck.

"Do you remember, Theodore, the card which you selected and shuffled into the pack? You do? Let me congratulate you. What was the card? The Four of Diamonds? You are sure it wasn't the eight or the nine? All right -- the Four."

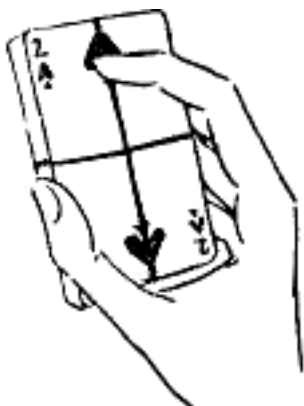
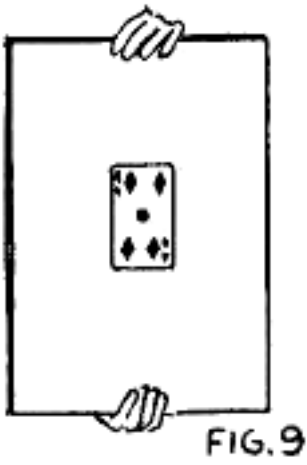


FIG. 8

Take deck and prepared Four of Diamonds in right hand. Hold as in Figure 8.

"Hold the board tight. One - two- three."



Then throw cards against the board so that they strike flat. The force of the throw and the weight of the deck will drive the tack into the board and fasten the Four of Diamonds securely on it. Figure 9.

(16-3)

The pack of cards falls to the floor, but does not scatter because of the rubber bands. The audience can see that it is still intact, bound by the rubber bands.

"The Four of Diamonds."

Take board from boy.

"Sit down, Theodore, and recuperate."

NEW ERA VERSION OF CARD THROUGH HANDKERCHIEF

This is a modification of an old magical experiment which is in every magician's repertoire. In its old form it was effective, but in its new dress it is even more wonderful. In the old version only one side of handkerchief could be shown after cards were wrapped. In this version both sides of handkerchief can be shown just before the card starts to penetrate the handkerchief.

EFFECT:

Spectator selects a card. This is returned to deck and shuffled thoroughly into it. Magician then borrows a handkerchief in which he wraps the deck and holds it up by the edges of the handkerchief. Both sides of handkerchief are shown. Performer then shakes handkerchief and the chosen card slowly comes down through the handkerchief and drops to the floor.

PARAPHERNALIA:

- 1 -- A deck of cards.
- 2 -- A borrowed handkerchief -- or performer may use his own.

SECRET AND PATTERN:

To Perform:

Borrow a gentleman's handkerchief and throw it over your left arm.

Request that a spectator select a card and remember it. Have it returned to deck. Perform the SIMPLIFIED PASS to get selected card to top of deck. Shuffle cards well to give audience impression that card is lost in deck.

Place handkerchief over left hand. Hold deck with right hand. Figure 10.

"There is a story told about a fairy godmother who tucks the little fairies in every night, just as I tuck these fairy cards away under this gentleman's handkerchief."

(16-4)

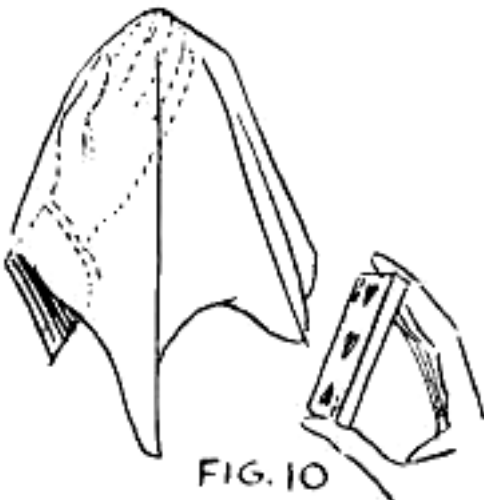
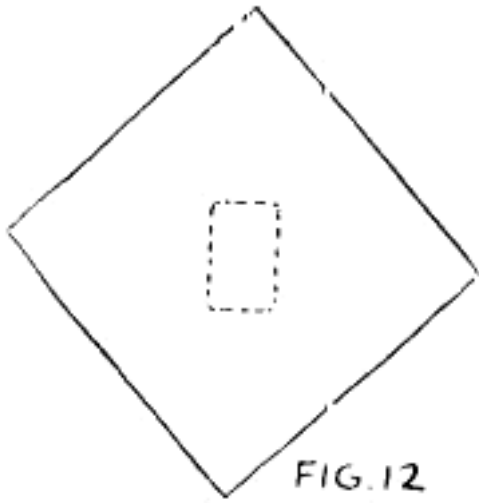


FIG. 10



Place right hand with deck of cards, faces up, under handkerchief. Remove left hand from under handkerchief, letting edges of handkerchief fall over right hand. Figure 11.

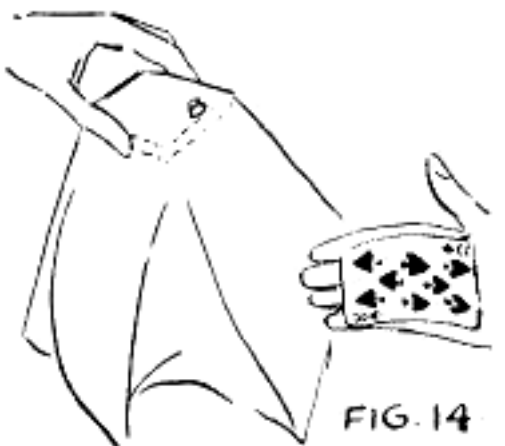


Note carefully the position of the cards in the handkerchief. They are diagonal to the edges and the two short edges are in line with two of the corners. Figure 12.



One corner of handkerchief hangs down over right arm toward audience, and the other toward yourself.

Reach over with left hand and grasp deck through the handkerchief. As you do this, quickly palm the selected card in right hand. Figure 13.

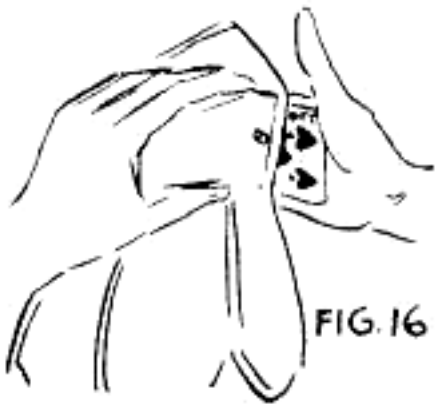


Remove right hand with card palmed from under handkerchief.

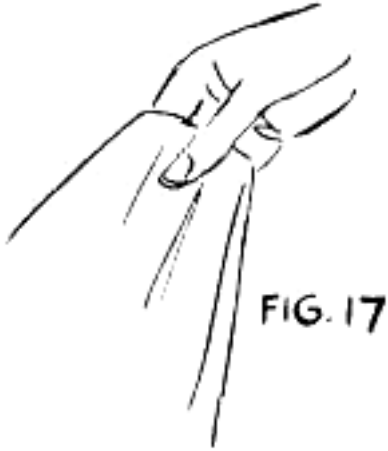
Remember to watch your Angles of Visibility and Naturalness in palming. Figure 14.



Rotate deck upward so that edge B comes up and deck is straight up and down. Figure 15.



Continue to rotate deck until you have it in position shown in Figure 16. Cards in handkerchief are in line with palmed card in right hand and outer edge of handkerchief falls over back of right hand.



Take cards and handkerchief in right hand, thumb holding them on side toward audience and fingers holding the selected card in back. Figure 17.

(16-5)

Figure 18 shows how selected card is held in back of pack and handkerchief by fingers of right hand. Left side of body is towards audience.



FIG. 18

Bring left hand up to pack and grasp it at end opposite that held by right hand. Figure 19.



FIG. 19

The moment that you grasp the deck with left hand, slip the selected card in back down about an inch and a half with right fingers. Hold this card in place with fingers and thumb of left hand clasped around deck and handkerchief. Figure 20.



FIG. 20

"I fold them in just so."

Fold left side of handkerchief to rear and over selected card. Figure 21.



FIG. 21

Then fold over right side of handkerchief so that card is now completely covered. Note carefully the manner in which the handkerchief is folded over the card with edges K and Y just concealing the card. Figure 22.

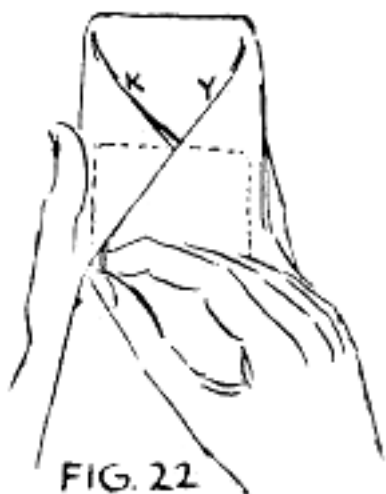
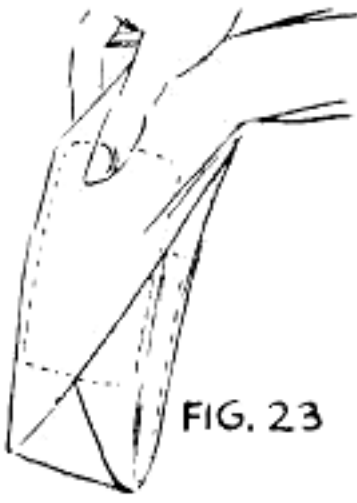


FIG. 22

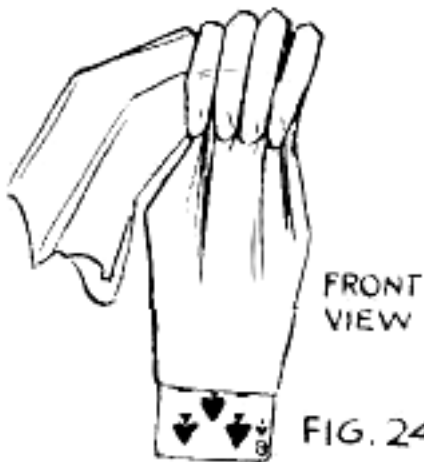


Now turn other end of pack up and hold deck and selected card through the handkerchief with thumb and fingers of right hand. Figure 23.

Show both sides of handkerchief to audience. They see nothing unusual about the rear side where the handkerchief is folded. Then turn folded side of handkerchief to rear again.

"But every night, one little fellow, when all the rest of the little fairies are asleep, slips away and runs out into the moonlight to dance and play and have a good time."

(16-6)



Begin to shake handkerchief slightly so as to allow first grip on selected card. The card slips slowly down and makes its appearance, apparently coming through the handkerchief. Figure 24.

"Here comes the little fellow now. The Eight of Spades. Was that your card, sir? Right through the fairy covers it comes and gaily flutters away."

Card drops to floor.

FIG. 24 Unfold handkerchief and show pack of cards still inside.

"And the rest of the fairy family are still asleep inside. As you see, the fairy covering hasn't been hurt a bit. That explains how Santa Claus comes down the chimney on Christmas Eve."

* * * * *

THREE CARDS THROUGH THE HANDKERCHIEF

EFFECT:

Similar to preceding effect, except that three cards are selected, remembered, and returned to the deck. The handkerchief is wrapped around deck as previously, and then the cards come through the handkerchief one at a time.

PARAPHERNALIA:

- 1 -- A deck of cards.
- 2 -- A borrowed handkerchief, or performer's own.

SECRET AND PATTERN:

To Perform:

Borrow a handkerchief and place it over your left arm. Pick up deck of cards. Figure 25.

Have three spectators select cards, remember them, and have them returned to pack. You, of course, keep track of these cards with your little finger. After each card is returned you supposedly place the two sections of deck together again, but in reality you keep them separated with little finger, so that each time you open deck at same place.

Thus when first card is returned, you divide deck into two sections and have selected card placed on top of lower section. You pretend to close up pack, but really keep little finger inserted over first selected card. Then you open deck again at same place and receive second selected card on top of first one. Then insert little finger over second selected card and pretend to close deck. Again open deck at same place and have third selected card placed on top of other two. Insert little finger above third selected card, and pretend to close deck up. Audience is not aware that you have



opened deck at same place each time. It appears that you have closed the deck after receiving each card and that consequently these cards are lost in the deck.

Now perform the SIMPLIFIED PASS bringing the three selected cards to top of pack.

Fan pack slightly and insert little finger of left hand under three top cards in preparation for Palming. Square cards again.

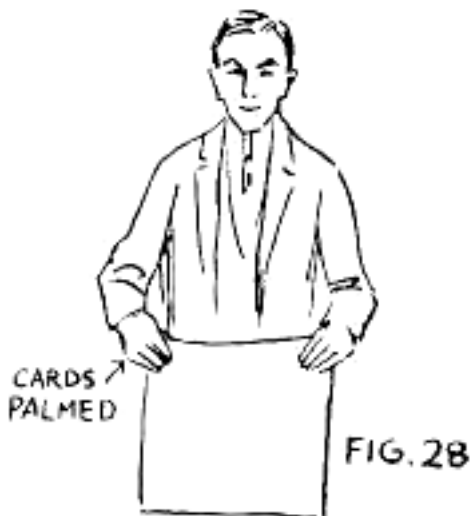


Pass right hand over deck in left hand and PALM the three selected cards in right hand. Give the deck in left hand to someone to shuffle. Figure 26.

"Give these cards your favorite shuffle."



With right hand containing palmed cards, grasp corner of handkerchief and pull it from left arm. Figure 27.



Grasp upper edge of front card with first finger and thumb shown in Figure 28. You will have no difficulty in holding corner of handkerchief with cards palmed in right hand. This helps to remove any suspicion from minds of audience that you have anything in right hand. Audience believes that you could not use hand so freely if you had something concealed in it. Figure 28.



Drop handkerchief from right hand and instantly move right hand up under handkerchief so that it is covered. Figure 29.

"I shall take the pack of cards and wrap it in the gentleman's handkerchief."



FIG. 30

Take the deck and place it on the handkerchief, directly over the palmed cards which are in right hand under handkerchief. Square deck and palmed cards even. Figure 30.

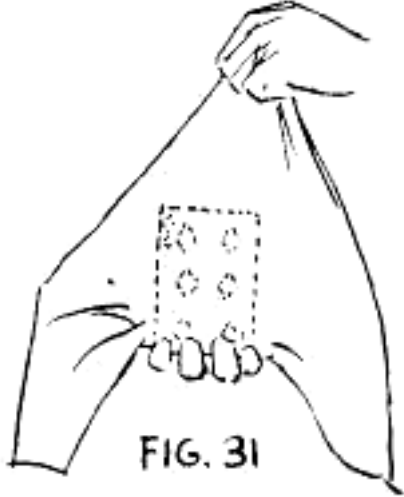


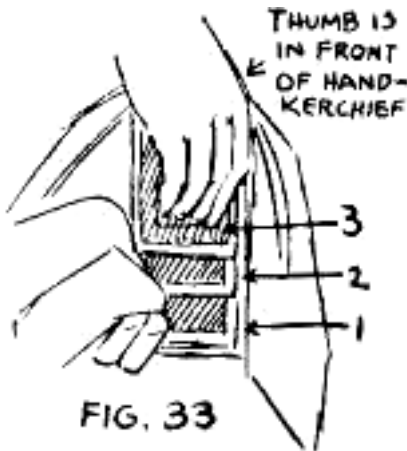
FIG. 31

Take hold of lower front corner of handkerchief and bring it up over the cards. Figure 31.

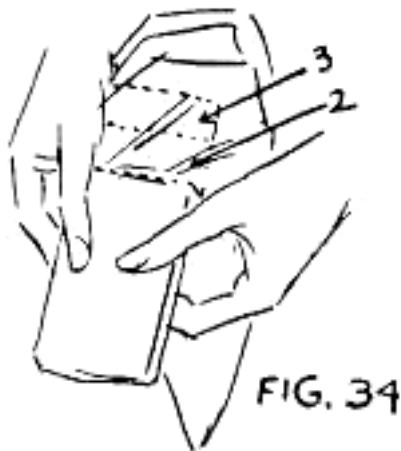
(16-8)



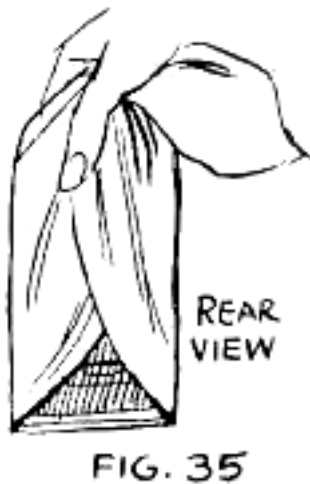
With left hand fold left side of handkerchief under around the three selected cards, making the same kind of fold as you did in Figure 21. Figure 32.



While doing this, spread the three selected cards upward with right hand. Thumb of right hand is in front of handkerchief, holding deck of cards and handkerchief. Left hand holds Card 1 tight against handkerchief and right hand spreads Cards 2 and 3 apart. Figure 33.

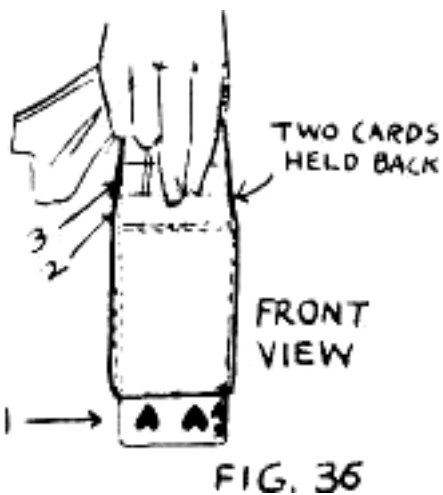


Then hold cards in place with left hand while you fold back right side of handkerchief with right hand, as you did in Figure 22, Figure 34.



Now hold handkerchief by the edges as shown in Figure 35. The two upper selected cards are gripped by right fingers and thumb.

"It is said that nothing is really solid -- that the solid bodies are in reality made up of atoms, each surrounded by space. Knowing this fact has proved very helpful in getting out of many a difficulty. It makes it possible to go through apparently solid objects with practically no trouble at all. Even this handkerchief is really a series of holes held together by thread. Let me shake it a bit. The atoms then separate, and anything inside can penetrate through."



Begin to shake handkerchief slightly, loosening your selected card to slip down slowly, giving the effect of coming through the handkerchief. Figure 36.

"The first gentleman who selected a card. What was it? The Five of Hearts. Come on Five of Hearts. See, it walks right through."

Let the card flutter to the floor, or take it when it is almost out of the handkerchief and drop it on table.

"The name of the next card, please. The King of Clubs? All right, King of Clubs, come right into sight."

Shake handkerchief and, as you do so, release your grip on the lower card of the two selected ones left. It will drop down and gradually work its way out.

"The name of the third card? The Seven of Spades."

Turn handkerchief around carelessly to show the rear so that audience can see that there are no cards there. The position of the card and the folds of the handkerchief, of course, conceal the card. It looks as though the deck were wrapped in the handkerchief completely. This puzzles even the initiated for they know only the old method and believe the card to be visible at the rear.

Turn handkerchief back again to former position with folds of handkerchief at back. Shake handkerchief and release hold on card. It, too, gradually slips down into sight.

"Here we come -- slow, but sure."

Take card when almost released, or let it flutter to floor.

"And the remainder of the pack."

Open up handkerchief and show deck of cards.

"Still in the handkerchief. And the handkerchief--just the same as usual."

Show handkerchief both sides as in Figure 28.

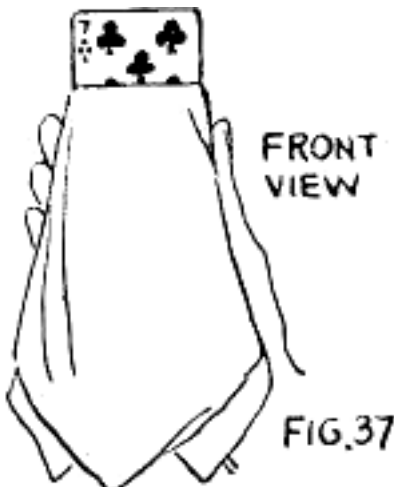
Place cards aside and return handkerchief.

* * * * *

RISING CARDS THROUGH HANDKERCHIEF

This effect is a variation for either of the two preceding tricks. Instead of holding the handkerchief and shaking it so that the cards slip out of the bottom, the position of the handkerchief is reversed so that the card or cards rise out of the top.

The card or cards can easily be pushed up by first finger of right hand. See Lesson 9, Figure 15. The same principle applies here.



The audience does not see your first finger working up the card. To them it appears that the card is slowly pushing its way up through the top of the handkerchief. Figure 37.

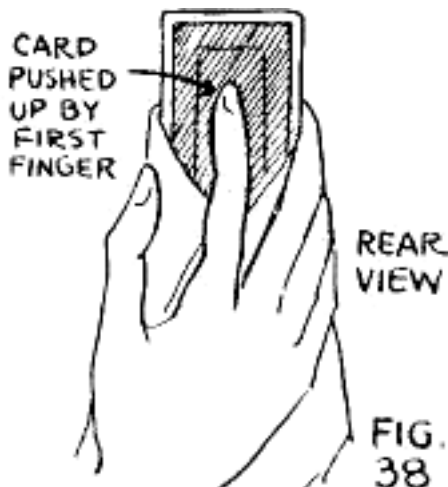


Figure 38 shows the rear view of your effect, which the audience does not see. Your hand is clasped around the deck in the handkerchief and your index finger is working the card slowly upward.

When three cards are caused to rise, you proceed in this manner: Place three cards together as if they were one. When making them rise, first push up the top one, then the second one, and finally the third.

Before the cards rise they are arranged as in Figure 35, except that handkerchief is turned to bring opposite end of cards up.

If you desire to show both sides of handkerchief before making the cards rise, simply push the cards back under the handkerchief so that they are concealed by its folds. Then after rear of handkerchief has been shown, push cards back into place. Only a slight movement of the right thumb will get the cards into position.

* * * * *

LESSON 17

From the wonderful repertoire of CARDINI, the eminent English conjurer and master of sleight of hand, come the fascinating card effects of the Seventeenth Lesson.

* * * * *

A handwritten signature in cursive script that reads "Harlan Tarbell". The signature is fluid and elegant, with a large, sweeping flourish over the "l" in "Tarbell".

Tarbell System, Inc. Chicago.

(16-11)

LESSON 17

It is with great pleasure that I introduce to you some very interesting card effects and "wrinkles" with cards which CARDINI, the eminent English conjurer and master sleight of hand performer, has given me.

CARDINI is a marvel at novelty sleight of hand. It would be well worth your while to make a special effort to see him should he appear in any theater near you. He represents a magician of the new school. His every move is studied to the nth degree. He possesses that NATURALNESS in performing which I keep accenting and emphasizing. Many of his moves are intricate, but so finished an artist is he that to the audience things seem to happen in such an easy, spontaneous manner.

I mention this because I want you to study people of the stage. Note carefully the vast difference between the inexperienced amateur who presents his program in a jerky, hesitant manner and the seasoned professional who performs with a smoothness and naturalness which is intriguing. Observe the ease, the finish, the poise, the power of magnetism of the carefully trained actor. See how he stands, how he moves about the stage, how he performs with confidence and mastery. Not a move to mar or distract from the big effect which he seeks to put across to his audience.

Such performance is your goal. You are working for this perfection -- this NATURALNESS and PROFESSIONAL FINISH which will make you a MASTER.

* * * * *

"SNAP IT"

An impromptu effect which can be performed anywhere at a moment's notice. The finish leaves your audience thoroughly puzzled.

EFFECT:

A card is freely selected by a spectator, remembered, and returned to the deck. The performer shuffles the deck well, then drops it into a borrowed hat. A spectator is given the hat to hold. Magician snaps bottom of hat with his finger and high into the air jumps the selected card out of the hat.

PARAPHERNALIA:

1--A deck of cards.

2--A borrowed soft felt hat.

SECRET AND PATTERN:

Ask a spectator to select a card freely, to remember it, and return it to pack. Divide deck into two sections, holding

(17-1)

one in each hand. Have spectator place selected card on top of lower section in left hand. Insert little finger of left hand above this card. Pretend to place the two sections of deck together again.

Then perform the SIMPLIFIED PASS to get the selected card to top of deck, pretending to shuffle the deck thoroughly.

"If you don't mind, I shall use your hat for a moment."

Borrow a soft felt hat which has a crease in the crown.

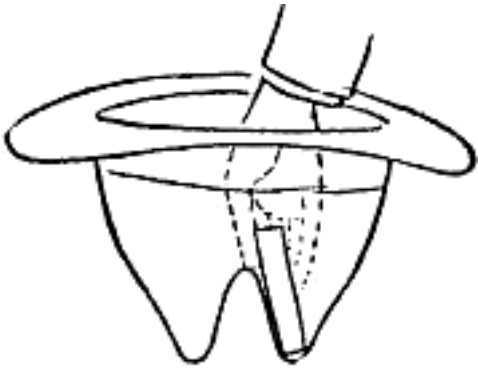


FIG. 1

Place the deck of cards inside of hat in the right hand groove formed by crease in crown of hat. Figure 1.



FIG. 2

Now slide the Top card, which is the selected card over into the opposite left-hand groove in the crown of the hat. Figure 2.

There should be no hesitation or fumbling in sliding the selected card over to the opposite side. It should be done smoothly and very quickly. The audience must not see inside of hat and must be led to believe that you merely placed deck inside of it.

"Fifty-two little birds all packed in like sardines -- I'm getting birds and fish slightly mixed -- but, anyhow, these little birds are all tucked in their nest high up in the tree. Will you please hold the nest up in the tree?"

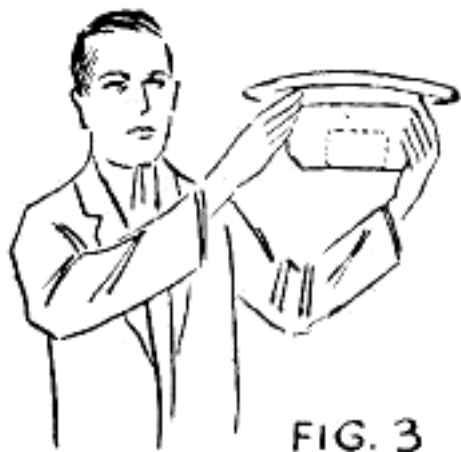


FIG. 3

Give hat to spectator to hold by the brim. Have him hold it up high so that he cannot see what is inside. Figure 3.

"That's right -- nice and high just like this."

Adjust the hat so that the selected card is on the side nearest to you.

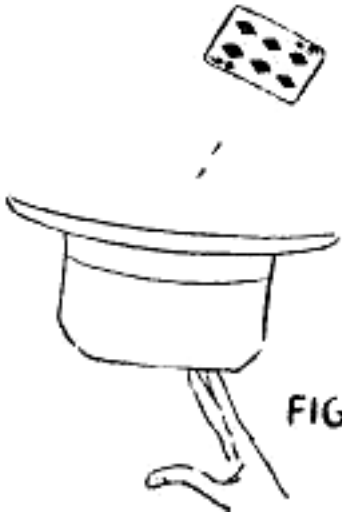
"What was the card you selected, sir? The Six of Diamonds?"



FIG. 4

With index finger or second finger and thumb of right hand in position under left side of crown of hat where selected card is, prepare to snap it up. Figure 4.

"One little bird decided that sleeping fifty-two in a bed wasn't so good so he up and left the nest just like that."



As you say, "just like that," snap the hat under the selected card. The snap will send it high into the air. Figure 5.

"There you are. The Six of Diamonds."

(17-2)

FIG. 5



If desired, performer may hold the hat himself with his left hand and snap the card out with his right. Figure 6.

* * * * *

FLASH CARD PRODUCTION



FIG 6

EFFECT:

Performer shows two wooden embroidery hoops. He places a sheet of tissue paper between them and pushes one hoop down over the other, forming a sort of tambourine. He then shows both sides of tambourine and his empty right hand. Suddenly he plunges his right hand through the paper and hoops, tearing the paper. Just as his hand appears through the paper a fan of cards is seen at his finger-tips.

PARAPHERNALIA:

- 1 -- A few cards.
- 2 -- Small wire clip such as is used to hold papers together.
- 3 -- Two wooden embroidery hoops, large enough for your hand to go through easily, about 8 1/2 inches in diameter.
- 4 -- Half-size sheet of tissue paper, colored.

SECRET AND PATTERN:

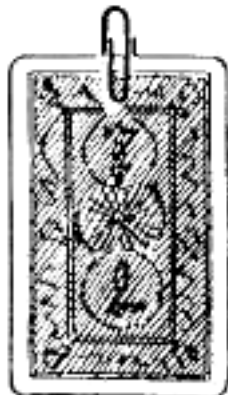


FIG. 7

To Prepare:

Take five cards and place them securely about half-way into the clip. Figure 7.



FIG. 8

Sew top of wire clip inside of right side of your coat. Position of clip should be far enough up from lower edge of coat to have cards about three-quarters of an inch from bottom of coat when it hangs naturally. Figure 8.

Figure 9 also shows position of cards under coat. They should be far enough from front edge of coat to enable you to reach them easily by curling your fingers up under your coat when your right arm is dropped naturally at your side. Cards face outward. Figure 9.

(17-3)

POSITION
OF CARDS
UNDER
COAT



Have the two embroidery hoops on the sheet of tissue paper on table. Tissue should be 14 1/2 x 20 1/2 inches.

To Perform:

This effect is most often used to blend in with other effects. It is very effective as a special opening for another trick in which a few cards are needed. Another excellent use for it is as a finish for the production of selected cards, duplicates of which have been forced.

CARDINI, himself, finds it valuable to use after having produced several fans of cards from the empty hand. He then picks up hoops and paper and pushing his hand through produces still another fan.

Cardini's trained skillful fingers can produce many cards at once. It is best to start with the production of a few, from three to five. Master this and then work up gradually to the production of many cards. Do the effect well with a few cards rather than bungle it with many cards. With practice will come greater and greater ability.

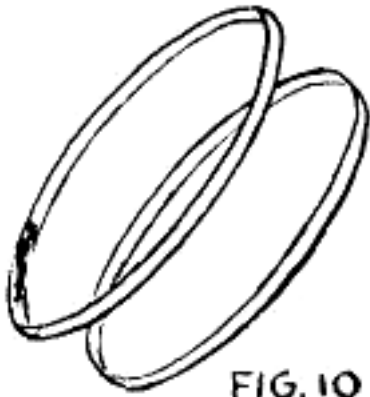


FIG. 10

Pick up smaller hoop and sheet of tissue paper. Show paper, both sides and place it over the hoop. Pick up the larger hoop and press it down over the paper and other hoop to make a tambourine. Figures 10 and 11.

Do this away from the table and stand in a position to enable your audience to see clearly what you are doing. They must see that there is no trickery in this tambourine.

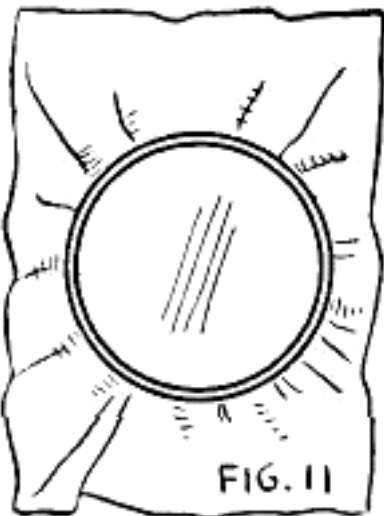


FIG. 11



FIG. 12

Hold tambourine with left hand. Outside of tambourine is toward audience. Right hand is held naturally at right side against the concealed cards under coat. Figure 12.

Turn tambourine over to show inside. The turning movement is made downward so that hoops come on a level with your right hand beside coat. Figure 13.

(17-4)



FIG. 13

As soon as right hand is well screened with the paper, reach under coat and quickly remove the five cards. Figure 14.



FIG. 14

Hand is drawn away with cards held as in Figure 15.

BACK HAND PALM:

The next move is to get the cards onto the back of the hand and hold them there so that they cannot be seen when front of hand is exposed to audience. This is an essential method of palming which must be mastered by every magician.

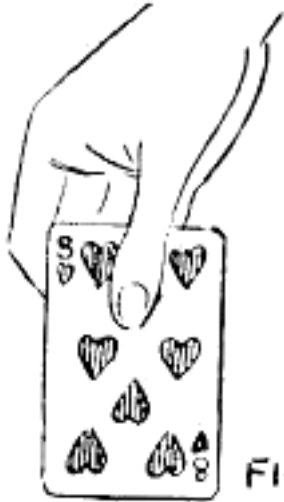


FIG. 15

Move first and little fingers to sides of card so that card can be easily gripped between these two fingers. Figure 16.

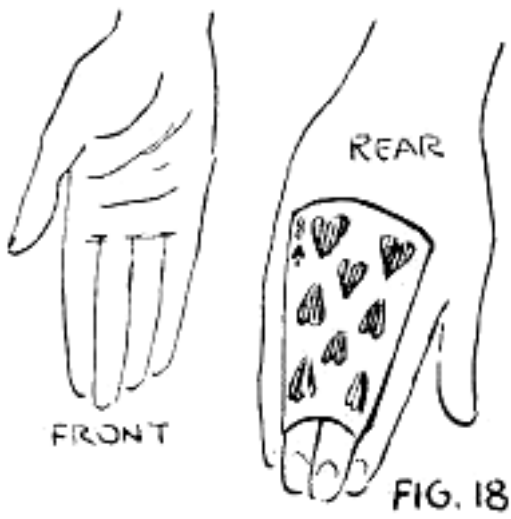


FIG. 16

Remove thumb from card, grip card in first and little fingers, and curl back second and third fingers. Hold card as in Figure 17.



FIG. 17



Straighten out the fingers and the cards automatically go to back of hand. They are held there, gripped between first and second fingers and between third and little fingers. Figure 18 shows front and back views.

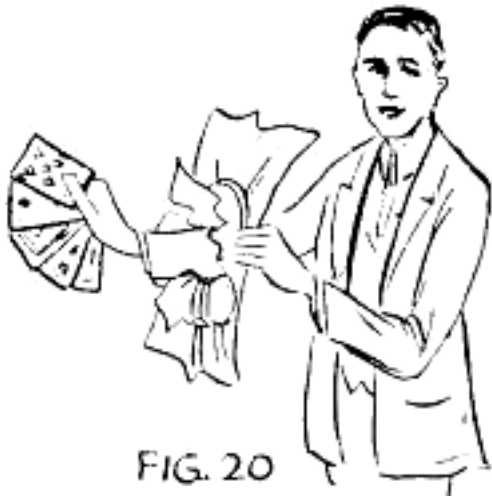
You must gain the ability to back palm like a flash. Start your practice using only one card, then as you gain greater skill in back palming, add more cards. The Back Palm must be done with one long, smooth, continuous movement to get card to back of hand, and then another move to bring card back to front again to be held as when you started the back palm, Figure 15.

After you have taken the cards from under coat, Back Palm them. Turn toward right a little so that your left side is toward audience. Bring hoop up so that outside is toward audience again.



Hold hoop as in Figure 19. Right hand is pulled behind it so that audience can see hand momentarily.

(17-5)



Then push right hand suddenly through the hoops, tearing the paper. The moment your hand is through the paper, bring the cards quickly from the back to the front of your hand by a reverse process (Figures 18-17-16) so that they are held as in Figure 15. Grip cards with tips of fingers at the back and suddenly move your thumb upward. This move causes the cards to fan. Figure 20.

The effect must be that the fan appeared at your fingertips right out of the paper. It will take practice on your part to perfect this production. You must bring the cards to the front of your hand and fan them in a flash.

The effect is very startling when this fan of cards suddenly appears at the tips of your fingers. You can understand how any slowness or fumbling in producing the cards would completely spoil the experiment. Practice then until you have it perfected to a nicety before you perform it before an audience.

As you acquire skill in this card production, add more cards to the number you produce.

NOTE:

Soft, unglazed Steamboat Cards are good for this type of work.

* * * * *

MYSTERY OF THE GLASS HOUSE

Another impromptu effect which leaves your audience thoroughly mystified. A clever and interesting experiment for parlor, club, or stage work.

EFFECT:

Performer requests that two spectators assist him, one standing at his left and the other at his right. Man at right selects a card, remembers it, and returns it to deck. Cards are then shuffled. Performer says he will cause selected card to appear on top of pack. He shows card but it proves to be the wrong one. Magician then isolates this card in a glass tumbler. He gives spectator an empty envelope to examine and seal. Assistant at left is then given the deck of cards and spectator at right is asked to think of any number between one and twenty. Suppose he says - Twelve. Magician says if the card in the glass is not the selected card, then the twelfth card must be the one. Spectator counts down to twelve, but the card there is also an indifferent card. Glass is then turned around and selected card is found to be there instead of the indifferent one placed there. Envelope is torn open and the card that was placed in the glass is taken from the envelope.

PARAPHERNALIA:

- 1 -- A deck of cards.
- 2 -- A glass tumbler (regular size)
- 3 -- An ordinary envelope -- about 3 1/2 x 6 inches in size.

To Prepare:

Have deck of cards, tumbler, and envelope on the table at your left and slightly back of you.

To Perform:

Ask two gentlemen to come up from audience to assist you. Suppose their names are Jones and Brown.

Have Jones stand at your left and a little in front of you, and Brown in a similar position at the right. Be sure that assistants do not screen your movements from the audience.

Pick up the cards, fan them, and ask Brown at your right to select any card, remember it, show it to audience, and return it to the deck.

After he has complied with your instructions, perform the SIMPLIFIED PASS to get the selected card to the top of the deck.

Then say to Brown, who has just selected card:

"It may seem quite remarkable, but the card you selected is having a difficult time in staying in the center of the deck and insists on coming to the top."

Lift up the "TWO" top cards and show as one.

"That, sir, is your card, is it not?"

Spectator, of course, denies this.

"No? That's strange. It must be. You are certain that it is not? If that's the case, I shall just isolate this card in this glass to keep it away from the other cards to prevent it from getting in the way again."

Place the pack of cards on table.

Pick up glass with left hand and place the TWO cards in it, facing audience. Let us assume that the indifferent card which you showed to audience is the Six of Spades. The selected card is back of this card, but, of course, the audience is not aware of this. They think you have merely placed this one indifferent card in the glass. Figure 21.

With right hand pick up envelope from table.

Say to Brown:

"Here is an envelope which I wish you to examine. See that it is empty and that there are no money orders, thousand dollar bills, or bathing suits present. Now, just seal it."



FIG. 21

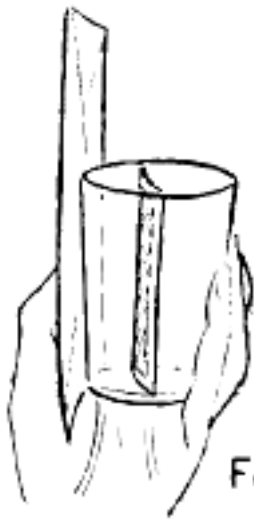


FIG. 22

Take envelope with right hand and place it behind the glass which is still in left hand. Hold envelope against glass with left thumb. Figure 22.



FIG. 23

Hold glass and envelope up in left hand so that audience can see card in glass. Pick up deck of cards with right hand and give it to Jones at left. Figure 23.

"Will you take the deck, sir?"

To Brown,

"And will you choose any number between one and twenty? Just any number. What is it? Twelve. Then if the card you selected is not the one in the glass, then it must be the twelfth card in the deck."

To Jones.

"Will you count the cards one at a time and let us see the twelfth card?"



FIG. 24

As you turn to ask Brown to select a number, you turn slightly to the right. This brings the glass and envelope around so that the envelope is in front of the glass and covers the glass and card. Figure 24.

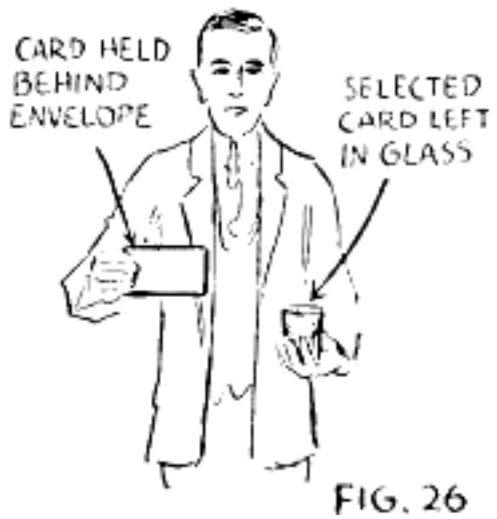


FIG. 25

As you speak to Brown, put right hand on top edge of envelope, fingers in front and thumb in back resting on Six of Spades. Figure 25.

As you speak to Jones, pull the Six of Spades up out of the glass behind the envelope. Use the envelope to accent gesture in talking and pointing to Jones.

It looks perfectly natural to pick up envelope for the gesture. Audience does not suspect that you have a card concealed behind it for they see the card in the glass and do not know you had two cards there. The back of the card in the glass is, of course, toward the audience and must be kept that way until the CLIMAX.



Hold envelope in right hand and glass in left hand while Jones counts down to the twelfth card. Figure 26.

Jones shows twelfth card. This, of course, is an indifferent card and not the one selected.

(17-8)

To Brown,

"Was that the card you selected? No? This IS strange. You say the card in the glass is not your card nor is the twelfth card your card. According to the laws of Magic if the card does not appear at the number you selected, IT MUST BE THE ONE IN THE GLASS."

Turn the glass and show selected card in it instead of the Six of Spades which the audience saw there formerly. Suppose the selected card is the King of Hearts.

"Is that right?"

Set glass on table with left hand and with same hand remove the card.

"The King of Hearts was your card? Correct. What card did you think was in the glass? The Six of Spades? No . . ."

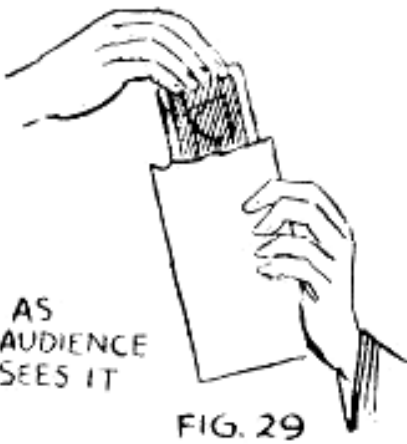
Drop the King on the table after saying, "Correct."



Place left hand on envelope and grasp card and envelope with fingers in front and thumb in back. With right hand tear off one end of envelope to open it. Figure 27.



With first and second fingers of right hand reach into envelope and open it up a little. You pretend that you are reaching into the envelope for something. The spectator knows that he sealed this envelope when it was empty. Figure 28.



Slant top of envelope back toward yourself a little so that audience cannot see top opening. Pull the card up from behind envelope. The effect is that you take the card from the inside of the envelope. Figure 29.

"The Six of Spades is in the envelope."

* * * * *

LESSON 18

Your next lesson is & tremendously interesting and valuable lesson. It is devoted to experiments with Rising Cards -- experiments which are fraught with mystery and entertainment.

Harlan Tarbell

Tarbell System, Incorporated, Chicago.

LESSON 18

RISING CARDS

Rising Card Effects are designated in the magician's vocabulary as "beautiful" effects. This means that these effects are especially clever and effective. And, indeed,

they are.

I do not know who first performed the rising of a card from the pack, but whoever he was, he certainly had a brilliant idea. It has stood the test of many, many years and many, many audiences and proved to be of real Magical value.

Thurston, the big spectacular magician, has made the rising card effect one of the feature tricks of his show for many years. Other magicians the world over, wherever playing cards are used, have put rising card experiments on their programs.

There have been many methods used in accomplishing the effect -- some very simple to perform, others very complicated. Many performers have exercised their ingenuity on rising card problems so that interesting variations of the effect have been brought forth. Some of these require apparatus which costs hundreds of dollars.

In presenting various rising card methods to you in this course, the idea has been constantly before me to give you those methods which are practical, which require only a medium amount of skill and yet are excellent in effect, and, above all, to present them to you in such manner as to enable you to make up the apparatus easily and with almost no cost.

I give you three good methods in this lesson. Varying conditions under which you perform require different methods of working and it is well to be prepared for any occasion. However, you will, no doubt, favor one of the methods over the others and find greater delight in performing the effect by this method. If experience teaches you that you are most successful in presenting this method, you can then make this your feature rising card effect.

* * * * *

CARDINI'S RISING CARDS

This effect was shown to me by Cardini. It is worked on the elaboration of an old principle in Card Magic which has been sold in crude form in circuses, carnivals, dime museums, street corners, and where not. It has commonly been called the "Jumping Card." In the crude method a rubber band was fastened to two cards in a deck and another card was placed between them, forcing down the rubber band. The card was held in place with the fingers. When it was released, the rubber band contracted and forced the card out of the deck, causing it to jump up into the air.

This method of Cardini is worked out to a nicety and is excellent for presentation in Club, Parlor or Stage work.

EFFECT:

Five cards are selected by spectators, remembered, and returned to the deck. Magician holds deck in left hand. He commands and the selected cards rise one at a time up out of the deck, until at the end the last two cards rise together. This gives the performer an opportunity to get in some comedy patter. After the cards have risen, the deck may be given to spectators for examination.

PARAPHERNALIA:

- 1 -- A deck of cards.
- 2 -- Two specially prepared cards.

SECRET AND PATTERN:

To Prepare:

Take an elastic band, about Size 18 as manufactured by Eberhard Faber and sold at any book or stationery store. Cut off one end of the rubber band. Be sure to use fresh rubbers and test them to see that they do not break easily.

Take the King of Clubs and the Queen of Diamonds from an extra deck. Cut a small hole in the upper part of each card. Through the hole in the King push one end of the rubber band. Pull it through until about an inch and a half of band from hole to curve in band is left on face side of card. Figure 1.

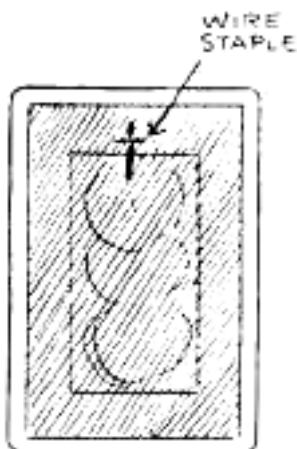


FIG 1

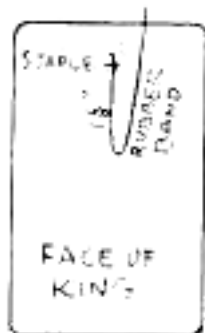


FIG 2

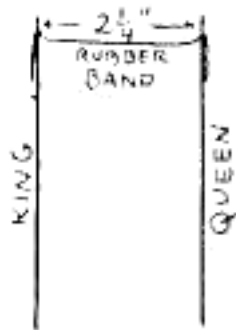
Figure 2 shows arrangement of rubber band on face of King. Now with a wire clamping machine, such as is used in offices to fasten papers together, clamp a staple across the rubber so that it fastens it securely on both sides of card.

Now take the Queen and push the other end of rubber band through hole in this card from the back through to the front. King and Queen should face in same direction and should not face each other. Treat the rubber band similarly as you did with the King.



FIG. 3

Figure 3 shows how the two cards look with rubber band hanging down between them and ends clamped to the cards.



Experimentation will teach you how tight and how long you will want the rubber band to get the proper rising of the cards. I have found the most satisfactory length of the band to be about two and a quarter inches when it is held straight out between the cards. Figure 4.

(18-2)

FIG. 4

To complete the band arrangement, cut the extra length of the bands from the two ends, allowing about a quarter of an inch to hang down beyond staples. You cut these ends from the back of the King and the face of the Queen.

If a wire stapling machine is not handy for your use, push the band through the King in the same manner as described above and sew it to the King with needle and thread. Then spread glue over the back of the card and on the rubber band and place another card over it. The two cards should be carefully glued together as one.

Now take any indifferent card and push the rubber through it as you did with the Queen in arrangement above. Sew band to this card. Spread glue well over the face of it and over end of rubber band. Place the Queen on this card, facing outward. Press cards together well to look like one card with band securely held.

The resulting arrangement looks just like that described above and shown in Figure 3.

Have prepared cards in center of deck, stapled ends nearest you. On "Top" of deck place a duplicate King of Clubs and Queen of Diamonds.

To Perform:

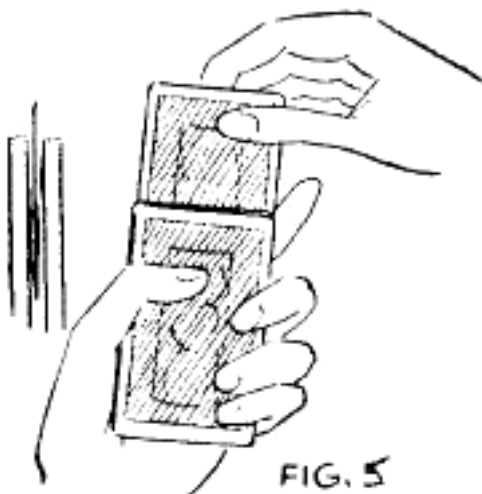
Insert little finger of left hand under the Queen of the prepared cards. Perform the PASS, thus bringing the King and Queen from "Top" of deck to the center and the faked King and Queen to the bottom of deck. Make the JOG in preparation for forcing.

FORCE the King of Clubs on one spectator and the Queen of Diamonds on another.

Allow three more spectators free choice of a card each.

Perform the PASS again, bringing the prepared King and Queen on the "Bottom" to the center of deck. Reverse deck so that stapled ends are toward audience. Cover end of cards with right fingers to prevent audience from seeing the space between prepared cards.

Collect cards one at a time in reverse order from which they were selected, that is, the last one first and the King and Queen last. As you collect each card, you return it to the deck in this manner:



Hold deck with A end upward, cards facing audience. Take card from spectator with right hand and place it in deck, between the two prepared cards. Figure 5.

(18-3)



FIG 6

Push card down with right fingers. This, of course, forces the rubber band down between the two prepared cards and is around D edge of the selected card. Figure 6.

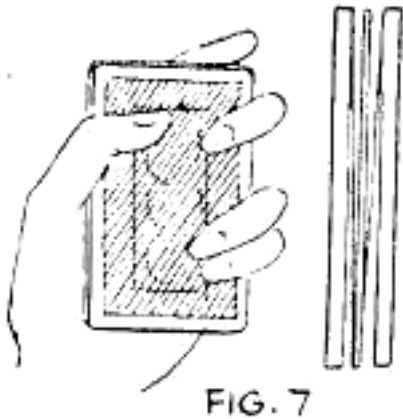


FIG. 7

Collect the next card and place it in deck on "top" of card just placed there. You will have no difficulty in finding this place in the deck. Then collect the third selected card and place on "top" of second, and finally collect the Queen and the King and place them on "top" of the other selected cards. All five selected cards are now between the two prepared cards. Figure 7.

Hold pack of cards firmly gripped in left hand with forefinger over top edge to keep selected cards from being pushed out.

"Some time ago I discovered something peculiar about the relationship between cards and people. It seems that when a card is held for a few moments by a spectator, it absorbs a certain magnetism which causes it either to get lighter or to separate itself from the others by the power of friction. For instance, here is one rising up now and separating itself from the others."

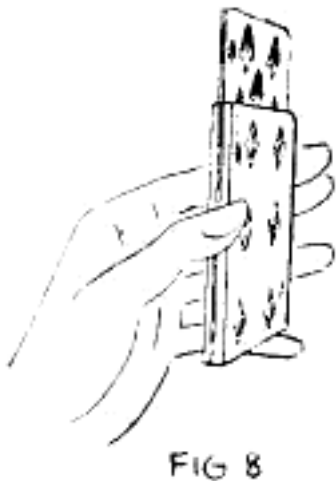


FIG 8

Hold deck as in Figure 8. Have little finger at bottom of deck to keep cards under influence of rubber band from coming out at bottom. Grip deck on one side with thumb and other side with fingers of left hand.

Gradually release your pressure on deck. This causes the rubber band to force the selected cards upward. Allow all five selected cards to rise up as one card. As cards are held squarely with faces toward audience, spectators are not aware that there are really five cards before them rising up out of the deck instead of one.

Permit cards to rise up just a little beyond half their length. Now study this move carefully, in which you remove the front card without letting audience suspect that there are other cards behind it.

Grasp upper edge of front card with first finger and thumb of right hand. Place left forefinger on upper edge of four cards in rear. Pull top edge of first card forward a little and pull it up with right hand. As you do this push the rear cards down into deck with left forefinger. Be sure little finger of left hand holds bottom of deck securely. Figures

9 and 10.

As you remove card from deck, call it by name: "The Three of Clubs" (or whatever card it may be).

Drop card on table or place it on front of deck.

Release pressure of fingers again and let the next card rise with the other three behind it. Remove the front card and push down the rear three as before.

Call the card.

(18-4)

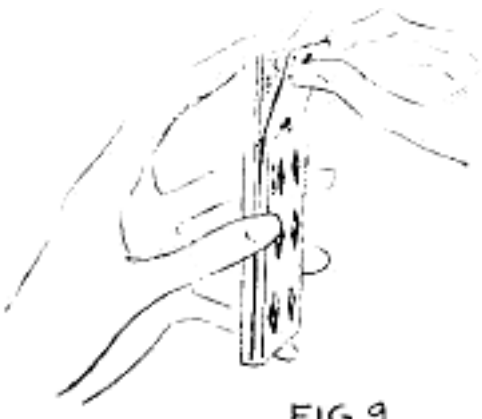


FIG 9

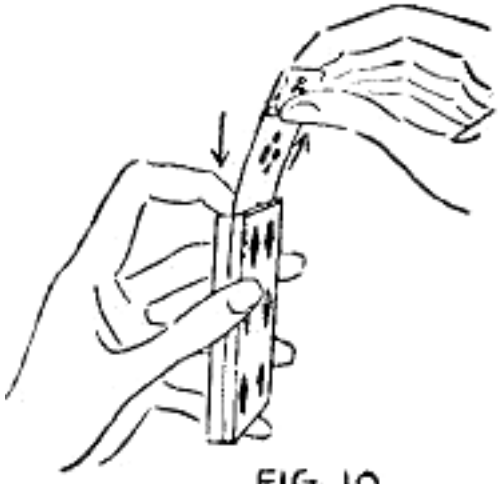
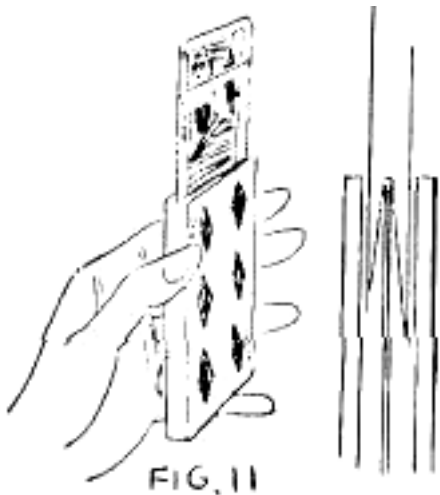


FIG 10

"The Ace of Spades" (or whatever card it may be).

Allow next card to rise with the other two behind it. Remove this card and force other two back into deck. Call card.

"The Ten of Hearts" (or whatever card it may be).



Now reverse deck. Release pressure again. The selected King and Queen, now under the rubber band, push up the prepared King and Queen and cause them to rise up from the deck. With a little practice you can cause the King to rise up first by releasing pressure on that card first. Figure 11.

"Ah, the King!"

Then the Queen rises up also.

"And the Queen! Either he is hiding behind the Queen's skirts or else she will not let him go out alone."

Remove the King and Queen, holding the right thumb over staple and rubber band. Fan cards a little and show them to audience. Figure 12.

Place these prepared cards on front of deck and then fan whole deck in right hand.

If you wish to continue using the deck after this effect, lay the selected cards on the table as they rise. Then when the King and Queen are out, the deck can be handled freely and can even be given to spectators to examine as the apparatus is gone.

NOTE:

There are a number of interesting ways to handle the Queen and King. You can control their rising by means of the first fingers of either hand, allowing one to rise and pushing the other down and vice versa. This gives you an opportunity for comedy patter to put your effect across with a bang. You may let the Queen rise up about an inch and then allow the King to shoot up behind it. The King can always be kept down until ready by means of the left forefinger.

Be prepared with patter no matter how they arise. If King comes up and Queen does not, reach in and pull out Queen, and removing both cards from deck say, "Ah, running away from the Queen, eh?"

* * * * *

THE RISING CARDS AND CARD CASE

A method for presenting a rising card effect which can be used for work at close quarters if necessary.

EFFECT:

Performer fans a deck of cards and divides it into two halves, giving one-half to a spectator. Spectator is requested

to remove any card from his section of the deck and place it among those held by the performer. Two other spectators, likewise, select cards and return them to section held by magician. All the cards are now placed in the card case and it is shown freely. On magician's command, the selected cards arise one at a time. You may permit spectators to remove cards themselves to prove to them that cards arise from center of deck.

PARAPHERNALIA:

- 1 -- Prepared deck of cards.
- 2 -- Prepared card case.

SECRET AND PATTERN:

To Prepare:

Talk half of a deck of cards. With a sharp pen-knife, cut out the central portion of one card as shown in Figure 13.

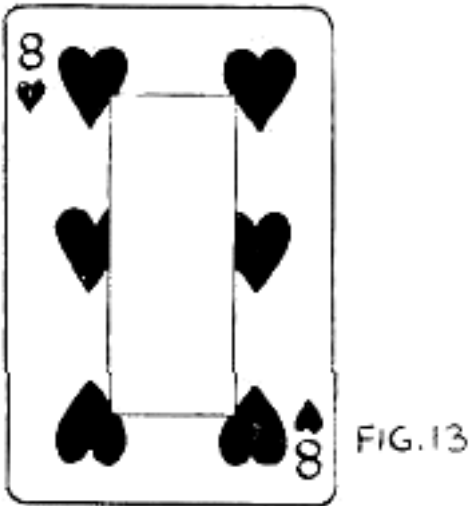


FIG. 13

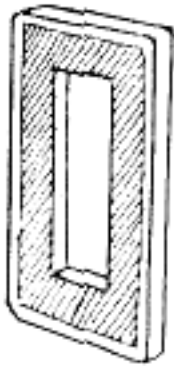


FIG. 14

Using this card as a guide, cut out the central portions of 23 more cards. Square up the 24 prepared cards and you will have a packet with a uniform rectangular hole running through them. Figure 14.

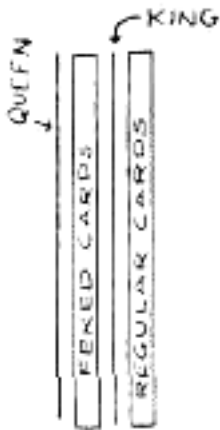


FIG. 15

On "Top" of these prepared cards place the Queen of Diamonds and on the "Bottom" place the King of Hearts. (You may use any other cards, just so you remember them as key cards. I merely suggest using the Queen and King.) Then place these cards on "Top" of rest of pack. Figure 15.

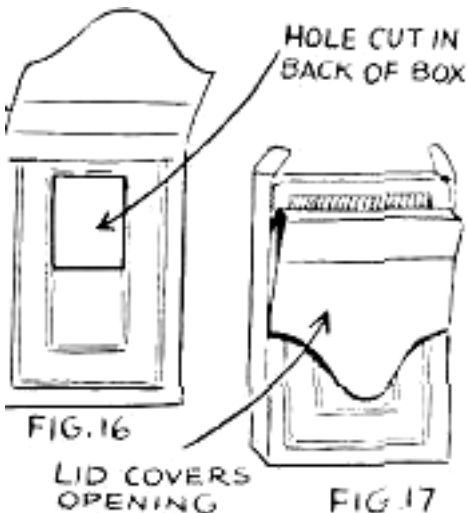


FIG. 16

FIG. 17

Take the cardboard case which cards came in and cut a rectangular hole in the back of box, about an inch wide and about an inch and a half in height. This hole should be so placed that when flap of box is pulled back it is completely covered. If necessary slit down the back cover of box about half an inch on each side to permit flap to go back farther. Figures 16 and 17. Usually, however, the box is already slit on each side.

To Perform:

Have deck in case when you start performing. Remove deck from case and place case on table with prepared side down and opening away from audience.

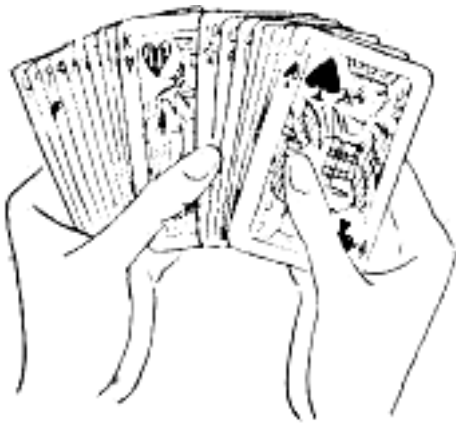


FIG. 18

Fan the deck with both hands. You will find that you have no difficulty in fanning the cards, showing faces to audience, without exposing the holes. Note where the King of Hearts is in the pack. Then separate the deck into two packets with the King of Hearts on the "Bottom" of packet in left hand. Figure 18.

Square up cards in each hand.

"Will you, sir, take this half?"

Give unprepared cards in right hand to spectator.

"Just remove a card, remember it, and return it to this half of the deck which I hold."

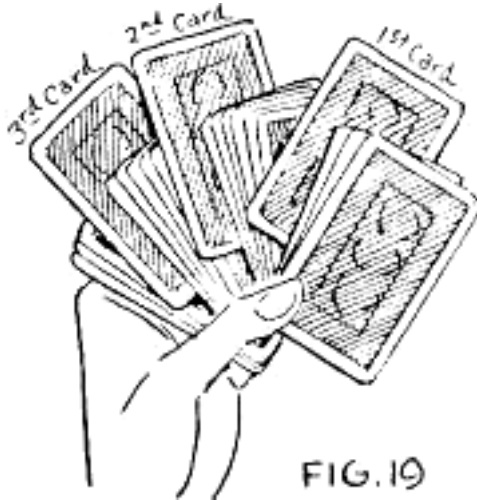


FIG. 19

Spectator places card among those which you hold. Deck should be held fanned out with backs of cards up. Have two more spectators select cards from unprepared section of deck and return them to section you hold. Have each selected card placed in a different part of packet. Figure 19.

Square up packet. Collect remainder of deck which spectator is holding and place these cards in front of packet you hold. Shift the Queen from "Top" of deck to "Bottom."

Pick up card case from table, being careful not to expose hole in back. Place deck in box with backs of cards against hole in back of case. Fold down the lid of box over the hole in case. Show box freely on both sides to audience.

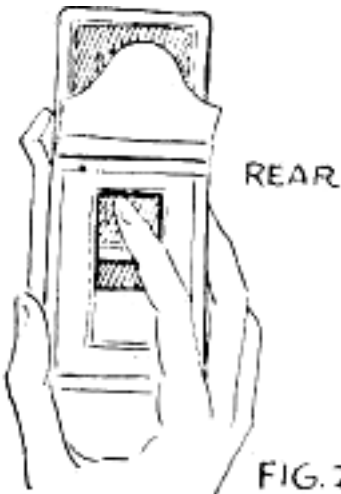


FIG. 20

Take box in right hand, front toward audience. Allow lid to fly up. Place forefinger of right hand against the first card exposed through hole in case. Figure 20 shows view away from audience.

To spectator who drew first card,

"Have you much influence with cards? Some people seem to have remarkable power over them. What was the name of the card you selected, sir? The Five of Diamonds? Thank you. Now you say, 'Five of Diamonds come to papa.' That's it."

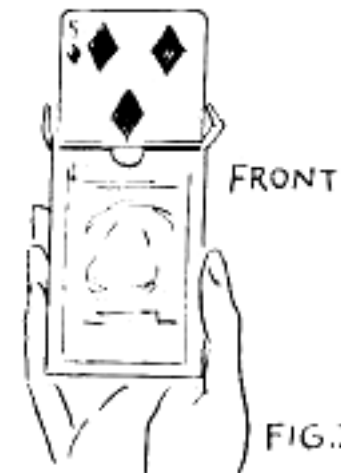
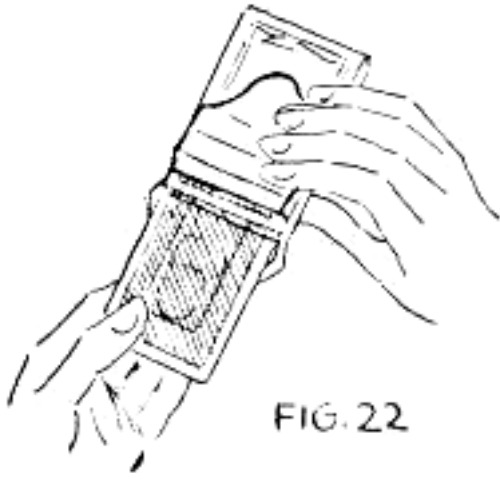


FIG. 21

With forefinger of right hand, which is in position, push up the first selected card -- in this case, the Five of Diamonds. Figure 21.

"Well, talk about influence! You not only make them sit up, but rise up."



Push down lid of box over hole in back and turn box over so that audience can see back of it. You must also show audience that selected card is rising up from among the other cards. Remove card with left hand. Figure 22.

You may drop card on table or, if more convenient, place the card back in the box in front of the deck.

(18-7)

To second spectator who selected card,

"Have you a similar acquaintanceship with cards? Will they shift around to suit you? The name of your card, please. The Ace of Hearts. Now say to yourself mentally, 'Ace of Hearts, walk right out and greet your friend'."

Push the Ace up with one push to make it rise about an inch, and then suddenly pull it down again.

"Ah, it's playing peek-a-boo with you."

Suddenly push card up until it is exposed for a few inches. Then make it jump up and down four or five times, pulling it down about an inch each time.

"Either you can't make up your mind, or else the card is shimmying."

Now push card all the way up and remove it with left hand as you did the first.

"And now for the last. Do not tell me what it is. Just think of it. Now concentrate. Up she comes -- the Six of Spades -- your card."

Remove card and place it in the rear of deck in the case.

Allow whole deck to slide out of box, being careful not to expose hole in box. Drop the case on the table with the hole down. Fan cards slightly, show them on both sides, square them up, and place them on table.

NOTE:

Another way of utilizing this principle is to use two decks. Prepare one by cutting a hole as described above through all the cards except the "Top" and "Bottom" ones. Place this deck in your lower right-hand vest pocket.

Come forward with regular unprepared pack in the prepared box. Remove deck from case and have three or four cards selected by spectators, giving the whole deck to each spectator to select his card from.

Then take pack. Request that spectators hold up their cards so that rest of audience can see them, but not the magician. So saying, turn your back to audience for a moment. This gives you a chance to drop deck into inner right-hand coat pocket and to remove the prepared deck from the vest pocket.

Have selected cards placed back into this prepared deck. Transfer "Top" card to "Bottom" of deck. Place cards in case

and proceed with experiment as described above.

RISING CARDS FROM GLASS TUMBLER

This is perhaps the most popular method of performing a rising card experiment. It is particularly suited to stage performance or working under conditions in which the magician is some distance from his audience. Magician must be far enough away and have such lighting conditions that a fine silk thread will not be visible to spectators.

EFFECT:

Three spectators select a card each. These are returned to the deck and thoroughly shuffled in. The deck is placed in a glass tumbler. A hoop is passed over glass and cards to show that there is no outside connection. The magician then commands and the selected cards rise one at a time. Cards and glass are examined by spectators after performing of experiment without their discovering the secret.

PARAPHERNALIA:

- 1 -- Two decks of cards.
- 2 -- A spool of very fine black silk thread -- Number AAA is best. If you cannot obtain it, use Number A.
- 3 -- A glass tumbler or goblet with bottom large enough to hold a deck of cards easily.
- 4 -- A wooden hoop, such as is used for embroidery work. It is effective to have this painted a bright color.
- 5 -- A table on which to set supplies.
- 6 -- A small wire staple.
- 7 -- A handkerchief.

SECRET AND PATTERN:

To Prepare:

Take one of the decks and remove the following cards:

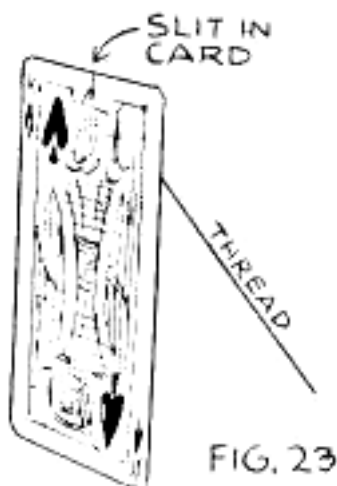
Queen of Hearts

Ten of Hearts

Ten of Diamonds

Seven of Spades

And Seven Indifferent Cards.



Take one of the indifferent cards, say, the King of Spades. Cut a small slit in upper edge A of the card, about one-fourth inch deep. Insert an end of silk thread into this slit, allowing about one-fourth inch to hang down on face of card. Figure 23.

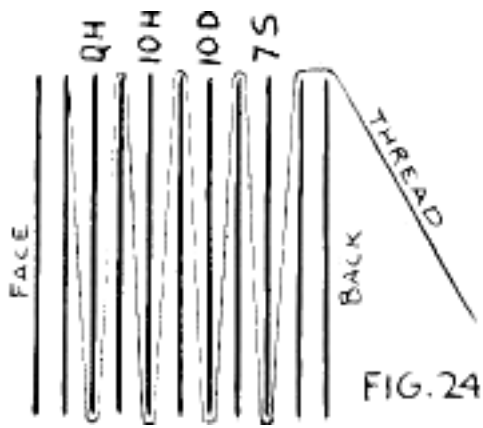


FIG. 24

Let thread come down over back of card, then place the Queen of Hearts on "Top" of it. Pull thread up over back of Queen exactly half way between the ends. On Queen and the thread place an indifferent card. Pull thread over back of this card. Now place the Ten of Hearts on "Top" and pull thread up again. Continue the threading of the cards, placing the Ten of Diamonds next, then an indifferent card, then the Seven of Spades, and finally two indifferent cards. Place the seventh indifferent card on the "Bottom" of the deck. Figure 24 shows you the set-up. All the cards must face the same way.

You can readily understand that if the thread is pulled the Seven of Spades will be pulled up as the back two cards act as a fulcrum.

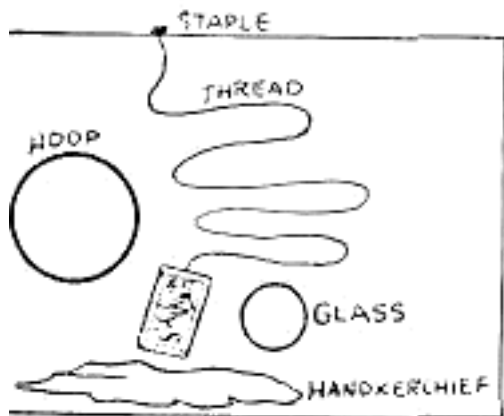


FIG 25

Figure 25 shows the arrangement of your table. The staple is driven in at the back end. To this the free end of the thread is tied. Determine the length of your thread by holding the cards about 18 inches above the table and about a foot in front of you. With cards in this position, the thread should be taut. Place prepared cards at front of table, faces up. In front of cards place a handkerchief to screen them from audience. Arrange thread carefully on table so that it will not get tangled or caught in anything. Place glass tumbler near cards at front of table and wooden hoop on opposite side and farther back.

On the other deck of cards place the Queen of Hearts, the Ten of Hearts, and the Seven of Spades. Arrange these in reverse order with the Seven of Spades on "Top" in preparation for FORCING.

To Perform:

FORCE the Seven of Spades, the Ten of Hearts, and the Queen of Spades on three different spectators respectively. Give the pack to each spectator and ask him to return his card to it. Finally have some member of audience thoroughly shuffle the deck.

Come back to table and place cards on the threaded cards with left hand, faces of cards up. At same moment pick up handkerchief with right hand and then the glass tumbler also with right hand.

"There is an old saying that people who live in glass houses should dress in the dark. It might not hurt this glass to give it a polish and make it still more transparent."

Show glass freely and wipe it out with handkerchief.

"This glass is of pure crystal, made especially for this magical experiment so that you can see through it -- that is, the glass and not the experiment."



FIG. 26

Drop handkerchief on table and pick up the cards. Place them in tumbler, faces toward audience. The thread hangs down behind the glass. Figure 26.

"You can see the cards in the glass, can you not? That is why I wanted the glass to be transparent. There is nothing left for you to imagine. 52 cards isolated in a glass house."

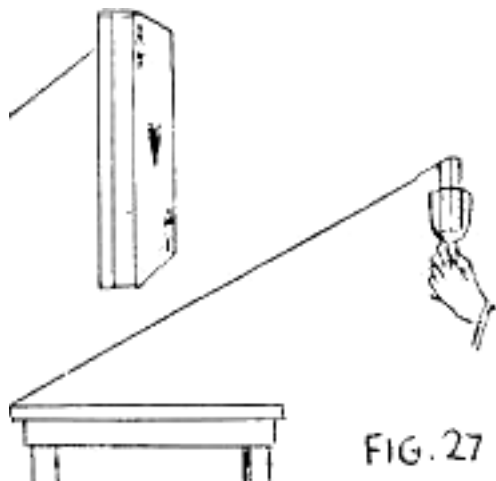


FIG. 27

Figure 27 shows the arrangement of cards - the unprepared deck facing the audience, behind it the threaded deck with thread hanging down behind it. You see here also how you hold the glass with the cards in your left hand in front of table, with the thread stretched straight out from back of table.

"I hear one card telling another that he might be in a glass house but that he cannot see much because of the others. Ah, there he is registering his dissatisfaction and coming out."



FIG. 28

Move glass slightly forward. This pulls the thread tighter and causes the Seven of Spades to rise because this is the last card which was threaded. Figure 28.

"The Seven of Spades. Was that your card, sir? Correct."

Pretend that you hear a murmur in audience.

"What's that? Oh, I know what you are thinking. You think that some spirit pushed the card out. Oh, my no!"



FIG. 29

Pick up the hoop from table with right hand and pass it over cards and glass. Practice how to do this so that you can do it very naturally. Place hoop above glass in a horizontal position. Figure 29.

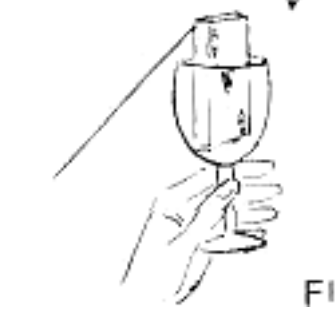


FIG 30

Bring hoop down over glass and onto left arm. Figure 30.

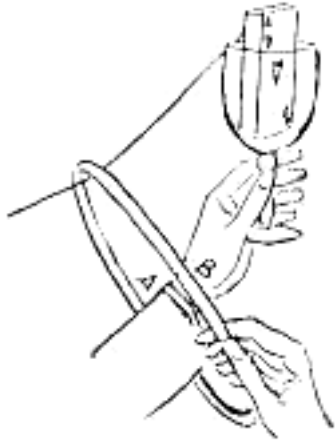


FIG 31

Shift left hand upward a little on glass. Now bring hoop to vertical position still on left side of glass. Figure 31.

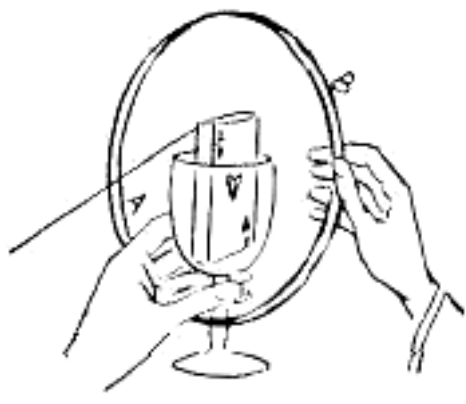
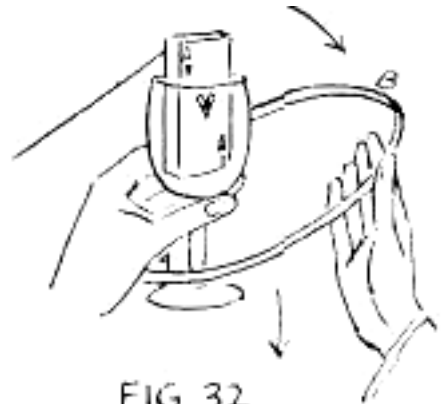


FIG 32

Pull B side of hoop over glass and down to a horizontal position again. Hoop is now clear of thread and can be pulled down over bottom of glass and removed. Figure 32.



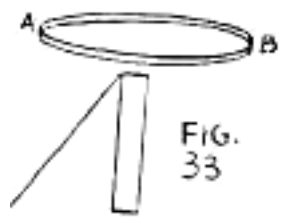


FIG. 33

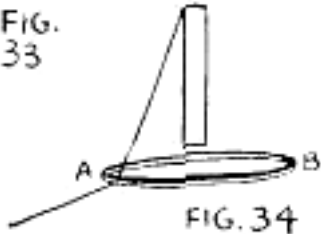


FIG. 34



FIG. 35



FIG. 36

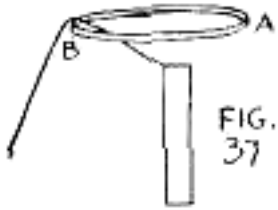


FIG. 37

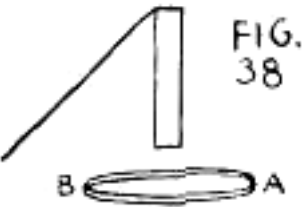


FIG. 38

Figures 33, 34, 35, 36, 37, and 38 show the routine of passing a hoop over a threaded object. Learn this thoroughly. It is exceedingly useful in convincing your audience that certain things have no outside connection, although they really have. Never mention anything about threads or wires. Do not even suggest the fact that magicians ever use such things.

Follow each step shown in the diagram and you will have no difficulty in learning how to perform this. Learn each stage of the move and then perform it quickly as one continuous movement.

(18-11)

"No 'spookses'. That card came out because of pure curiosity."

To spectator who selected second card, "And what card did you select? The Ten of Hearts? Ten of Hearts, arise!"

By this time you have stepped forward a little to take up slack in thread. You now push glass forward a little again, causing the next threaded card to arise, which is the Ten of Diamonds.

"I said the Ten of Hearts, not the Ten of Diamonds. Your card was the Ten of Hearts, wasn't it, sir? The Ten of Diamonds is so anxious to break into society that it breaks in wherever there is the slightest chance."

Push card down into glass again. This leaves it threaded as before. Move glass back a little to give thread enough slack to enable you to push card down easily.

"We'll try again. Up, Ten of Hearts!"

Up comes the Ten of Diamonds again.

"What? Coming up again? You are a naughty, naughty card."

Place glass on table and remove the Ten of Diamonds from deck in glass. Place it in the palm of your left hand, back up. Spank card about four times with right hand.

"Papa will have to spank. Now you go back with the rest of the little 'cardses' and stay there."

Return card to front portion of deck so that it will not interfere with remaining threaded portion of prepared deck. Pick up glass from table again and hold in left hand as before.

"Perhaps you would have more influence with your card, sir. Will you just say, 'Ten of Hearts, arise'?"

When spectator says this, permit the Ten of Hearts to arise. This is the next threaded card and it will come up readily if your thread is taut.

"I think the Ten of Hearts likes you better than it does me."

Remove Ten of Hearts and place on front of deck.

"Now, for the third and last card. Up - up - up."

No card comes up. Look at the deck a moment, perplexed.

"Did you see any card come up? If any did, I can't see it. (To spectator who selected third card.) What was the name of your card, may I ask? The Queen of Hearts? Oh, no wonder. We cannot expect a Queen to rise under ordinary circumstances."

Make a low graceful bow, and as you do so, say,

"Could we have the delightful pleasure of having your gracious majesty arise so that we might gaze on your gorgeous beauty?"

Let the Queen arise.

"All hail the Queen!"

Stand up straight again. Remove the Queen and place it on the front of the deck.

Push glass forward a little. This causes the thread to pull out of the slit in the King card which you started your threading from. This frees the glass and deck entirely.

Take deck from glass and fan it wide with right hand. Also show glass freely.

Replace deck and glass on table.

SUGGESTIONS:

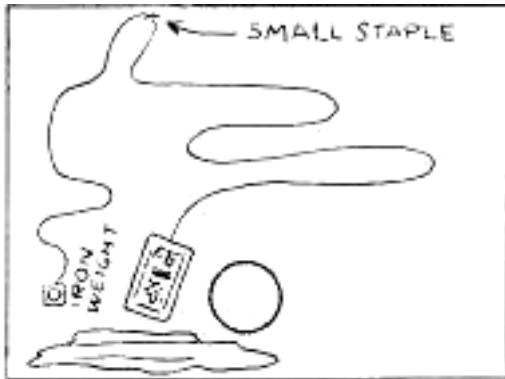


FIG. 39

There are numerous ways of applying this principle in the working of the rising cards. One method is to arrange your table as shown in Figure 39. Everything is set in the same way as described in preceding effect, except that thread is not tied to staple at back of table, but is pulled through it and tied to an iron washer or nut or small weight. Enough thread is allowed to enable the performer to stand several feet away from the table with weight in his left trouser's pocket. The glass with the cards is not held in the hand but remains at the front of the table.

Have table set as in Figure 39. FORCE cards you desire selected as above. Have them returned to pack. Place pack on the prepared cards already on table.

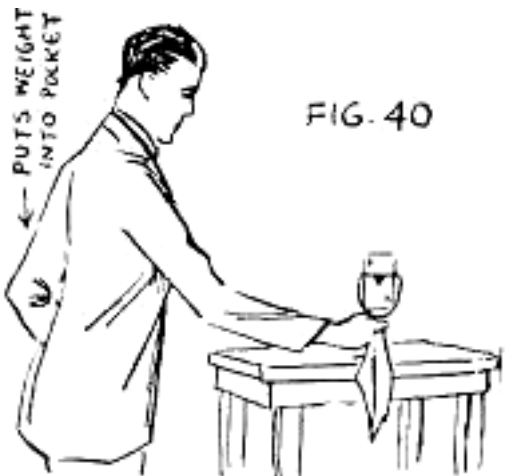


FIG. 40

Pick up handkerchief and glass with right hand, and at same time pick up iron weight with left hand and place it in your left trouser's pocket. This move will not be noticed for the leaning of the body makes such a movement appear natural. Also you are using MISDIRECTION—directing the attention of the audience to the handkerchief and glass. Figure 40.

Proceed to wipe glass as before and place it on table. Pick up the deck and place it in glass, faces of cards toward audience.



FIG. 41

Now stand far enough away from table to make thread taut. Move your body slightly and the pull on the string will cause the first threaded card to rise. You may make a movement of your hands toward cards to cover your body movement, or gesture with right hand and push left hand against thread. Figure 41.

(18-13)

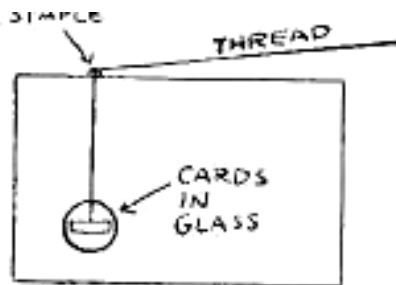


FIG 42.

Assistant Method:

This is a popular method when magician carries an assistant with him. In this case, thread is passed through the staple on back of table and then to floor where it is passed through a second staple. Figure 42.

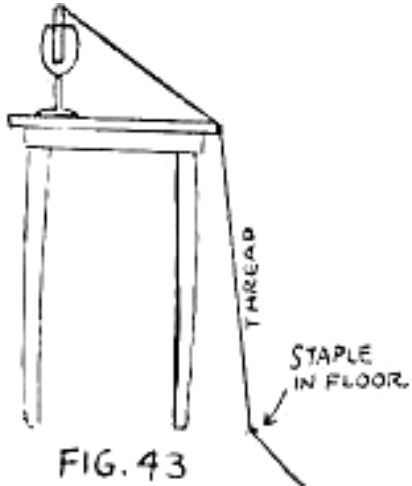


FIG. 43

Thread is then stretched across stage to wings where an assistant holds it and causes cards to rise. Figure 43.

IN PERFORMING THESE RISING CARD EXPERIMENTS, REMEMBER NATURALNESS IN YOUR MOVES. THERE MUST BE NO SUGGESTION OF PULLING.

LESSON 19

Interesting Rising Card Experiments from my own repertoire. Among them are these effects:

1. Three cards are placed in an examined envelope by a spectator. In a most mysterious manner, they suddenly rise out of the envelope.
2. Another method of causing three selected cards to rise out of an envelope.
3. Three selected cards rise out of a book after having been dropped in here and there amongst the pages.
4. An impromptu card rising out of a book.
5. Deck of cards is placed in glass and covered with a soft felt hat. On command the three chosen cards rise through the hat.
6. Deck of cards is dropped into a hat. Three cards rise in a bewildering fashion from hat.

* * * * *

Harlan Tarbell

Tarbell System, Inc. Chicago.

(18-14)

More fascinating RISING CARD EFFECTS are revealed to you in this lesson. When you have studied and mastered the preceding lesson and this one, you will have an interesting group of Rising Card Experiments at your command. For every occasion you will have one or several of these clever effects to work into your program.

With the effects in this lesson I teach you some construction work. It is essential for the magician to know how to build his own effects. The accomplished magician is not only an inventor and a creator, but he is also a builder. The tremendous cost of having apparatus built and the inability to guard secrets in this way has made it necessary for the magician to be a constructionist.

You must now start to study the construction side of your chosen profession. Build each effect in this lesson. You will find the instruction and experience you gain invaluable to you. It will help you greatly in planning and constructing your own original effects.

THE ENCHANTED CARDS AND ENVELOPE

EFFECT:

Three cards are selected by members of audience. A spectator then places them in an envelope and seals them in. Magician places this envelope in a small open metal frame which is on an upright stand. The top of the envelope is cut off with a pair of scissors. Upon command the selected cards rise up out of the envelope one at a time.

PARAPHERNALIA:

- 1 -- A deck of cards.
- 2 -- Spool of fine black silk thread.
- 3 -- Heavy manila envelope, 3 5/8 x 6 1/2 inches. (Can be purchased at a stationery or printer's shop.)
- 4 -- A special tin or brass case.

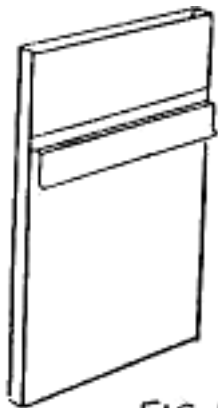


FIG. 1

You should have this made by a tinner or metal worker. It should be large enough to hold 10 cards easily. It must not be too small or you will have difficulty in making the cards rise out of it. About one-third of its length from the top, have a tin ledge by which the case can be hung on a frame. Paint the case a dull black. Figure 1.

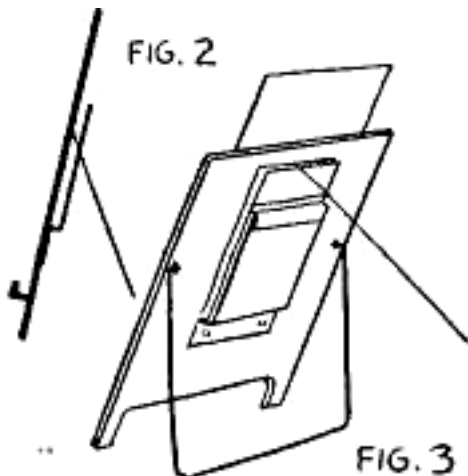


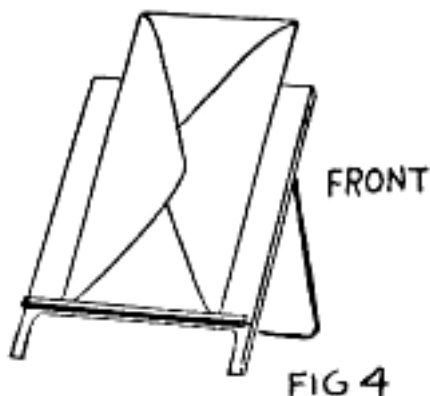
FIG. 2

FIG. 3

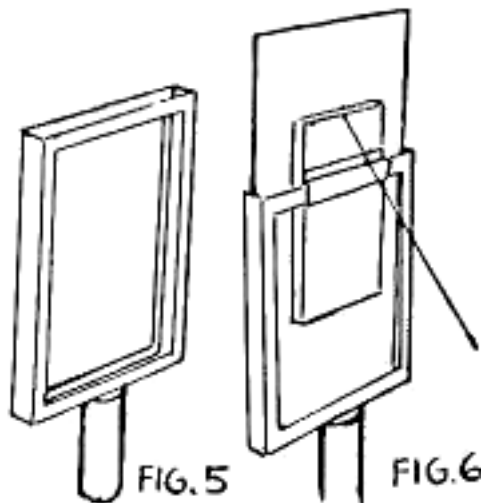
- 5 -- A special stand for holding envelope and tin case.

Get a thin board. Cut it out at the bottom to make two legs. On the front side of the board attach a ledge to support the envelope. Varnish, stain or paint board an attractive color. On the back attach a tin holder painted black to support the tin case with cards. Hinge a piece of wood onto the back or attach a bent wire to hold the board upright. Figure 2 shows side view of the stand and Figure 3 shows back view.

If desired, open work may be cut into the board and backed up with a piece of black cloth to conceal the arrangement at the back.



From the front it just appears that the envelope is resting on board which is propped upright. The audience does not suspect any mechanical arrangement behind it. Figure 4.



6 -- A metal frame.

This may be made of tin or brass and painted a bright red. It should be large enough to hold the envelope and case with cards. The ledge on back of tin case for cards fits over top edge of this frame. On the bottom is a holder by which frame may be put onto a base or pedestal. Figures 5 and 6.

7 -- A base or pedestal to hold frame.

The upright may be made of metal or wood. You may use a piece of metal piping and paint it black with a wooden base gilded with gold bronze. The pedestal should be about 2 1/2 feet high so that when whole apparatus is put together its height is about three feet. Figures 7 and 8.

8 -- A pair of scissors.

SECRET AND PATTERN:

To Prepare:

Take any three cards -- in this case, the King of Diamonds, the Eight of Spades, and the Ten of Hearts. Thread them with four other indifferent cards. (Refer back to Lesson 18 for method of threading cards.) Place the threaded cards into the black tin case. Place tin case in tin holder on back of the envelope stand.

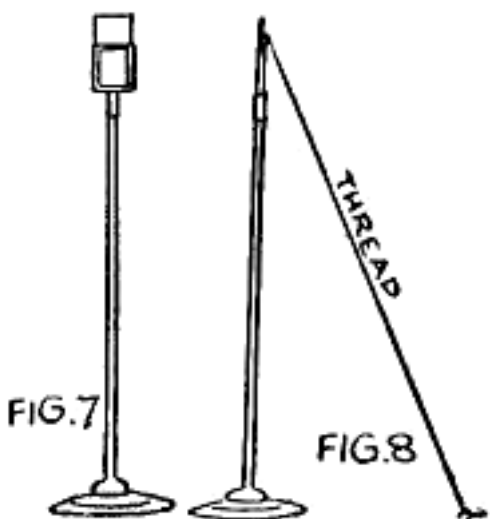
Carry the thread through a staple on the floor a little back of where you intend to place the pedestal. Figure 8. Then run the thread off stage to an assistant for him to operate at your command. Or if you operate it yourself, attach an iron washer to the end of it and place on table, eventually to be placed in your trouser's pocket. In this case allow yourself the proper amount of slack in the thread.

Place the empty envelope on the stand. In front and to the right place the pedestal with the metal skeleton frame on it.

Take a deck of cards and remove the King of Diamonds, the Eight of Spades, and the Ten of Hearts. Place them on "Top" of deck in readiness for FORCING.

To Perform:

FORCE the three cards on three different spectators.



Pick up envelope from stand, open it, and show it empty. Give it to first spectator who selected card.

(19-2)

"Just see that the envelope is empty and place your card inside."

Take envelope and pass it to next spectator.

"And will you please place the card which you selected with the other card in the envelope?"

This done, go to the next spectator.

"Place your card in the envelope with the other two and then seal the envelope."

Have cards placed in envelope so that they face to front of it. If you find that cards are not placed in right, just remove them under pretense of showing them to audience again. Then replace them and have someone seal the envelope.

Or, another way of working is to notice which way cards are placed in envelope, facing front or back, and then place envelope on the stand so that cards face outward regardless of which side of envelope is out.

The point of this is to make sure that you do not have the cards rising face outward from the front of the envelope (supposedly) when the spectators placed them in with backs to front of envelope.

Keep envelope always within sight of audience. Place it again on envelope stand. Figure 4.

Go to pedestal. Remove skeleton frame and show it freely on all sides.

"I can see you as well through this side (look through frame at audience) as I can through this side" (reverse frame and look through other side.)

Pick up the pedestal and set it down again.

"Someone said that this skeleton frame on top of this pedestal would make a good lighthouse if it only had a light in it."

Place frame back on pedestal.

Pick up envelope from stand. As you do so, place thumb in front of envelope and fingers behind stand so that you can lift up also the tin case with threaded cards. Do this easily and naturally as though you picked up only the envelope. Keep the tin case well hidden behind envelope.

"I told the gentleman that we'd try to have a little light on the subject and would fix up a lighthouse with keepers and everything."

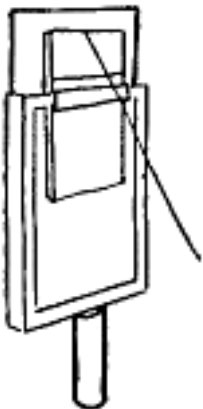


FIG. 9

Place envelope in frame, allowing ledge on back of tin card case to hook over top edge of frame. Figure 9.

(19-3)

"How's that? This envelope makes a good look-out station."

Pick up scissors and cut about three-quarters of an inch from the top of the envelope.

"We shall cut a hole in the roof, or make a window on top, or something. We have three good watchers inside in the form of the three cards that were selected. Yo ho! Yo ho! A ship in sight!"

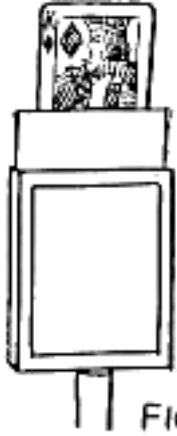


FIG 10

Assistant pulls thread and first card rises up. Or if you are performing alone, move backwards enough to make the card rise. Figure 10.

"Watchman Number One is right on the job - the king of all he surveys. Your King of Diamonds, sir."

Remove the King. To the audience, of course, it appears that the card rose up from the envelope. Though the card really came up from behind the envelope, the illusion is perfect.

"Another ship."

The next threaded card is caused to rise.

"And another watchman on the job. (To spectator who drew card.) You see, sir, he doesn't want you to go on the rocks. The Eight of Spades was your card, was it not? Eight bells, and all's well."

Remove card.

"The boys are working in shifts. Next shift!"

Assistant causes Ten of Hearts to rise more slowly.

"A little lazier than the rest. (In a loud voice.) A shipful of pretty girls in sight!"

Assistant pulls thread quickly. This, of course, causes the card to rise up suddenly.

"That's getting some action."

Remove card.

NOTE:

Another way of making frame for envelope and tin card case is to have a flat piece of tin or heavier metal soldered to bottom of frame to form a base for it to stand on. This eliminates the pedestal but makes it necessary for you to have a table on which to set the frame. Figure 11.

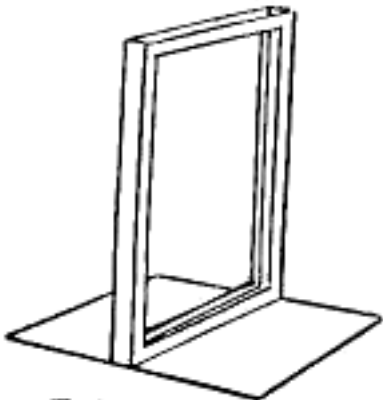


FIG. 11

If card case, or houlette, as it is commonly called, is made of brass it can be nickel plated.

* * * * *

BEWITCHED RISING CARDS AND ENVELOPE

This is another variation of the envelope method of performing rising cards. It is easy to prepare and simple in operation.

EFFECT:

Three selected cards are placed in an envelope and envelope sealed. Top of envelope is cut off. Magician commands, and up rise the three cards out of the envelope, one at a time.

PARAPHERNALIA:

- 1 -- Two decks of cards.
- 2 -- Fine black silk thread.
- 3 -- A double heavy manila envelope, 3 5/8 x 6 1/2 inches in size.

Refer to Lesson 8, pages 10 and 11 for description of Double Envelope.

- 4 -- A pair of scissors.

SECRET AND PATTERN:

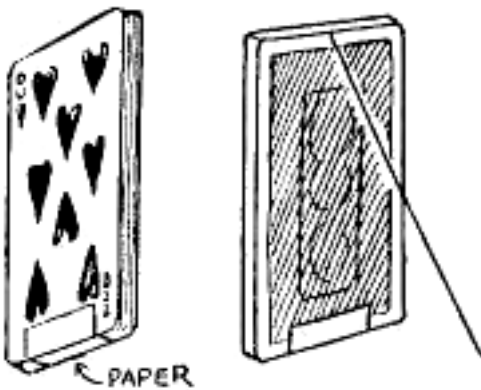


FIG. 12

To Prepare:

Remove the Six of Clubs, the Jack of Spades, and the Ten of Diamonds from one deck of cards. Thread them between four indifferent cards. At the bottom edge of one outer card paste the end of a strip of paper. Draw this under the rest of the cards and paste the other end of it at the bottom edge of the other outer card. This will keep the cards between from falling down. Figure 12.

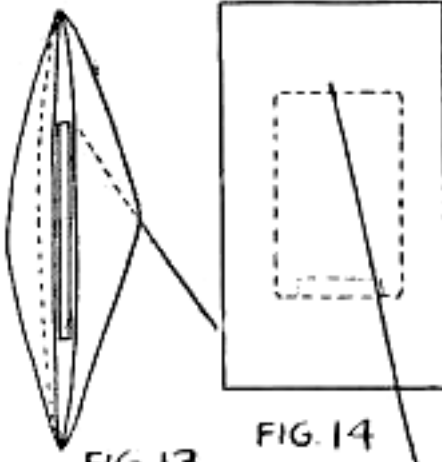


FIG. 13

FIG. 14

Run end of thread through back of envelope with the aid of a needle. Place cards in rear division of envelope. Put a little glue on each outside card and paste back of envelope and partition down on cards to hold them in place. Figures 13 and 14.

Now paste both flaps of envelope together so that envelope looks like an ordinary one. If you have prepared the cards carefully, they will not be noticeable.

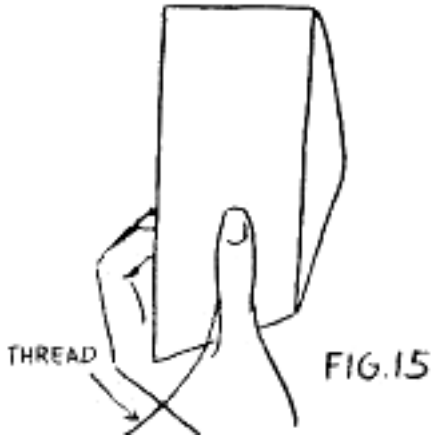
Have prepared double envelope on table. Have end of thread attached to back of table, as explained in Lesson 18. The length of thread should be about the same as in RISING CARDS FROM GLASS TUMBLER in that lesson. Experimentation will teach you the exact length of thread for practical results.

Place duplicate Six of Clubs, Jack of Spades, and Ten of Diamonds on top of other deck in readiness for FORCING.

To Perform:

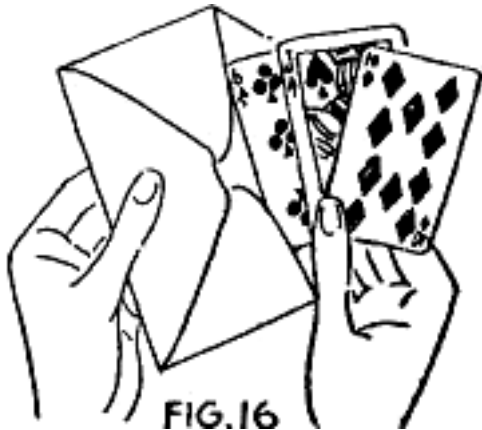
FORCE the Six of Clubs, the Jack of Spades, and the Ten of Diamonds on three different spectators. Then collect the cards and hold them up in right hand so that all can see them.

Call cards by names and hold them in full view as you turn to drop deck on table and pick up envelope with left hand.



As you pick up envelope from table, place left thumb over spot where thread comes out. Show envelope on both sides, then bring threaded side to rear. Figure 15.

"An envelope is commonly used for sending letters, but in this case, we will send a card instead. For good luck, we'll make it three cards."



Show the envelope empty and place the three cards in it. Spread the cards fanwise and hold them with faces toward audience so that all can see that you actually put them into the envelope. Figure 16.

Seal the envelope.

"By sealing the envelope it becomes a first class package -- which is quite necessary for a first class experiment before a first class audience. So, then, we mail the Six of Clubs, the Jack of Spades, and Ten of Diamonds from here - (Place envelope in right hand and hold it as far to the right side as possible. You stand facing audience.) -- to here. (Bring envelope in a semi-circle with a sweep over to the left hand, which should be extended a little to the left.) That is what they call fast air mail. Let us open the envelope, and see what the mail man brought."

Pick up scissors and cut about half an inch from top of envelope. Lay down scissors and hold envelope in left hand.



Gradually bring the envelope forward so that thread is drawn taut and first card arises. Figure 17.

"A code message. An uprising at ten o'clock a. m. Someone is going to get up at ten o'clock tomorrow morning. Coming right up out of cover."

Remove Ten of Diamonds with right hand. Continue moving so that thread is stretched taut and the Jack of Spades slowly arises.

"Ah, his name is Jack. There is a dark man in the case. He carries a Spade. Said he is going around trying to dig up a girl friend for the party tonight. Maybe, a blonde."

After a card has risen, remove it from envelope.

"He doesn't seem to have any visible means of support."

Cause the third card to arise - the Six of Clubs.

"A six. Six Clubs. Six Clubs all in one night. That's what they call stepping out. How does he do it? But the mystery is solved. The woman pays and pays."

Remove the card. Pull the envelope forward again. This move releases thread from slit in front card and releases envelope from thread. You can now turn envelope around and bring it forward to show audience that it is apparently an ordinary envelope.

Drop cards and envelope on table.

NOTE:

Sometimes for a finish I tear the envelope with the selected cards in it through the middle, then place both pieces together and tear it again.

If you do this carefully and with a flourish, audience cannot see the cards inside and believe that there is nothing left in the envelope. This is added SHOWMANSHIP. You have not shown envelope to be empty after cards have risen, but tearing it accents the fact that there is nothing inside.

The tearing is not necessary, however, for audience has seen the cards rise and does not suspect that anything is left in envelope.

If you have an assistant, you may have him cause the cards to rise by pulling thread from the wings as explained in previous effect.

* * * * *

MYSTERIOUS BOOKMARKS

or

RISING CARDS FROM BOOK

EFFECT:

A very pretty experiment in which three selected cards are placed in different parts of a book. The book is closed, yet on command they arise one at a time.

PARAPHERNALIA:

1 -- Two decks of cards.

2 -- A book.

About 5 x 7 1/2 inches is a nice size. Preferably an old book.

3 -- A tin case.

This should be large enough to hold 9 cards easily. Bottom edge is closed. Top edge is open. You can have a tinner make this for a nominal sum. In emergency use card board. Figure 18.

4 -- Fine black silk thread.

(19-7)



FIG 18



FIG 19

To Prepare:

Near the front part of the book cut out enough space to fit tight around the tin card case. Figure 19.



FIG 20

Glue the tin case into the hole cut out for it. Then glue one page down over each side of the case. Figure 20.

The book may now be shown freely with opening of case away from audience. The pages may also be run through except for the prepared part and the audience will not suspect anything.

Thread three cards which you are going to force between four indifferent cards. In this effect, we shall take the Ace of Spades, the Two of Hearts, and the Nine of Diamonds. Place the threaded cards in the case with thread hanging over top edge of book. Now attach end of thread to back of table as described previously.

Place book on table, prepared edge away from audience.

Take other deck of cards and place the Ace of Spades, the Two of Hearts, and the Nine of Diamonds on "Top" in readiness for FORCING.

To Perform:

Pick up book from table.

"Sometime ago in looking over the books in a second hand store, my attention was called to this one. I picked it up, and as I did so, I noticed a peculiar action on the part of the bookmarks. The bookmarks, strange to say, were playing cards, and they acted queerly. Being a conjurer, I naturally became attracted to the peculiarity of the happening. I purchased the book and brought it home with me. On close examination I discovered some odd facts about it. I have often wondered about the former owner. I am curious to know whether he was a conjurer or interested somehow in mysticism. I have never discovered the real secret of this peculiar book, but I have learned some of its peculiarities. For instance, let me show you something about its bookmarks. This deck of cards will answer the purpose nicely."

Place book on table and pick up cards. Perform the PASS, thus bringing the desired cards to the center for FORCING.

"Will you, sir, be kind enough to select any one of these cards for the experiment?"

Force card on this spectator, then continue with two other spectators, forcing the two remaining cards.

Collect the three cards and show them to audience, calling them by name. Hold them up high so that they are in full view as you place remainder of deck on table.

Pick up book again.

"I shall let these cards represent bookmarks."

Run carelessly through loose pages of book. Open book wide in one place.

"In this place, I shall put the Ace of Spades."

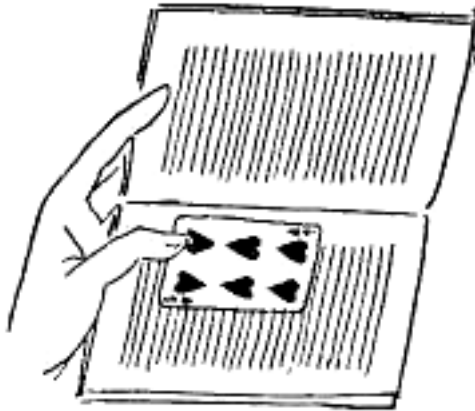


FIG. 21

Run through a few more pages and place the Six of Hearts in another place in the book. Show audience that you actually put the card inside of the book. Figure 21.

"Here I shall place the Six of Hearts."

Put the remaining selected card in a third place in the book.

"And in still another place I shall put the Nine of Diamonds."

Close the book and show it on both sides, being careful to keep top end away from audience. Hold book in left hand as in Figure 22.

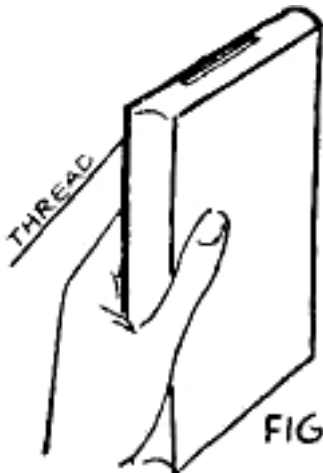


FIG. 22

"Now suppose that I want to turn quickly to the place where the Ace of Spades was placed. I have but to give the Ace a thought and out it comes to tell me of its location."

As you say this, pull the thread taut and the Ace in the tin case arises.

"All I would have to do is to open the book here and find my place. Or suppose I want to find the place where the Six of Hearts is located. I have but to think of the Six of Hearts, and it immediately presents itself and remains here until I remove it or reach in to open the book at the desired pages."

Move book so that the Six of Hearts will rise. Then remove the card. Figure 23.



FIG. 23

"And now there remains the Nine of Diamonds. An odd card that. It so happens that if you use a nine spot for a bookmark, you must knock on the book three times before it will appear. I learned this secret by accident. The nine would not arise, so I struck the book, and luckily I struck it three times."

Strike book three times with knuckles of right hand.

Pull thread taut again, and the nine arises.

"And thus the Nine arises to tell of its location."

Remove card.

"Perhaps you can explain it. I cannot. These bookmarks are as puzzling to me now as they were the first time I performed the experiment."

Lay book and cards aside.

* * * * *

A BOOK AND A CARD

This impromptu Rising Card Effect can be done anywhere at a moment's notice. It is surprising and puzzling in its effect.

EFFECT:

A card is dropped inside of a book. Magician shows the book on both sides and his empty hands to the audience. Suddenly the card rises up in a bewildering fashion from the book.

PARAPHERNALIA:

1--A deck of cards.

2--A book.

SECRET AND PATTERN:

To Perform:

Run through the pages of the book to show that nothing is concealed. Then give book to a spectator to hold.

"Would you mind holding this book? You don't have to read it."

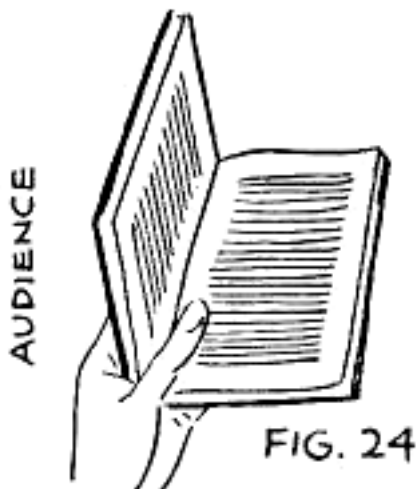
Give deck of cards to another spectator and ask him to select a card.

"Just take out any card from the pack."

Take book from first spectator and open it about in the middle. Request that second spectator drop card into book.

"Please drop the card into the book. By the way, did everyone see what the card was?"

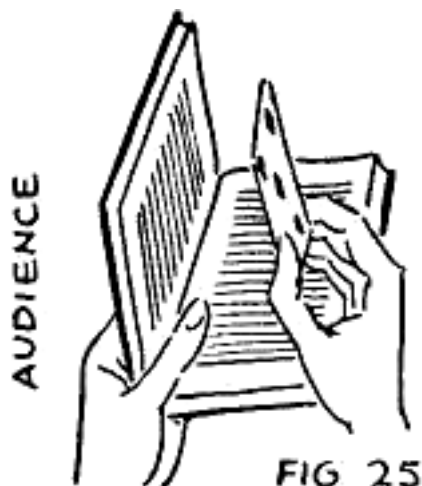
Pick up card with right hand. Hold book in left hand with one side toward audience in a vertical position. Figure 24.



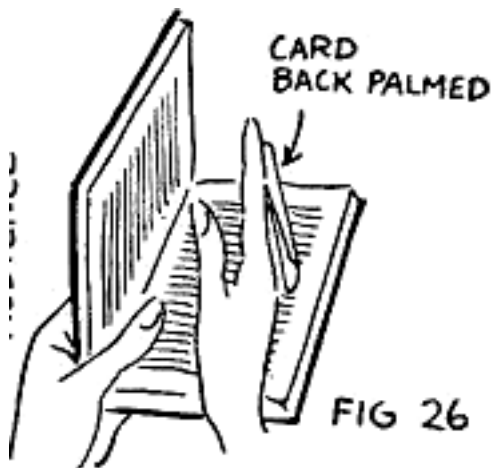
(19-10)

"The Five of Diamonds."

Name the card, whatever it happens to be.



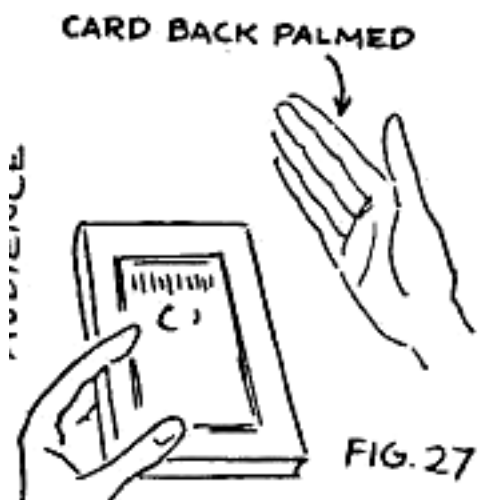
Hold book as in Figure 24 with front cover facing audience. Hold card in right hand in readiness for BACK PALMING. The position of the book should screen your right hand. Figure 25.



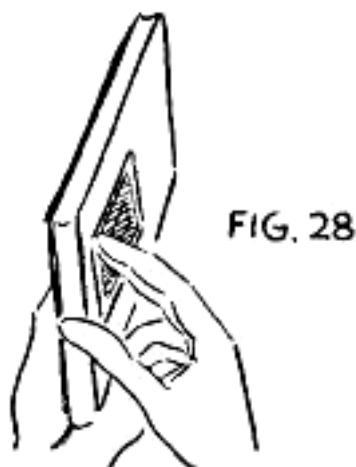
"I'll drop it into the book again."

As you say this, you apparently drop the card into the book. Your hand makes the motion. It is thus brought back of the cover of the book, which is in a vertical position and screens right hand. As soon as hand is screened, BACK PALM the card. Figure 26.

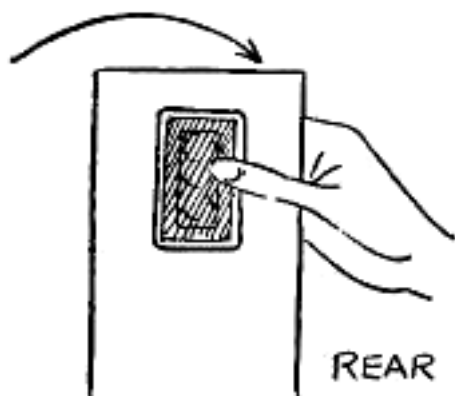
BACK HAND PALMING is taught to you in Lesson 17 under the effect, FLASH CARD PRODUCTION. By this time you should be proficient in performing it. It is a very important principle and must be mastered.



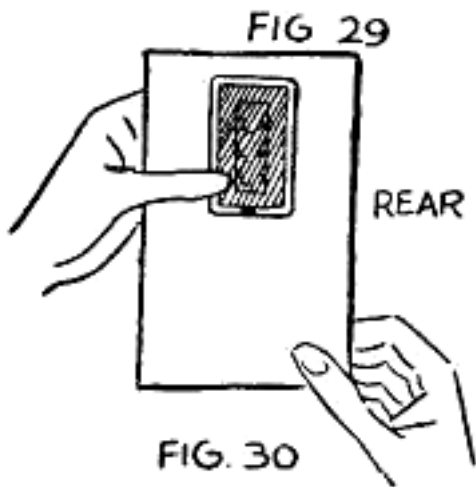
Now raise right hand with card Back Palmed out of the book and close book with left hand. Show palm of right hand empty and show book on both sides to audience. Figure 27.



Turn book up to vertical position again. Bring your right hand back again behind the book. Manipulate the card back to finger tips and place it against the back cover of the book. Hold it there with tips of fingers. Figure 28.

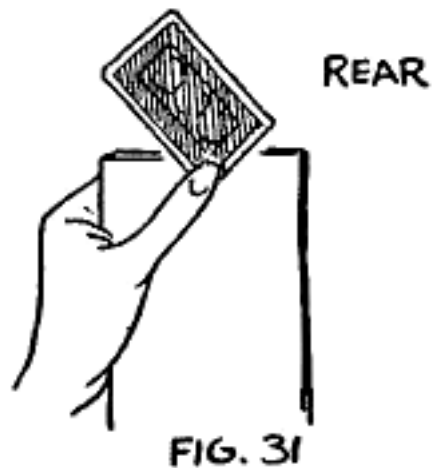


Swing book around to upright position, taking care not to expose card at the back. Now hold card with thumb of right hand. Figure 29.



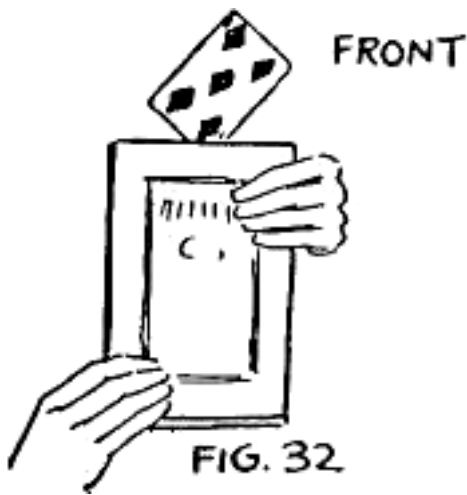
Bring up left hand and place left thumb against card, fingers in front of book. Now place right hand at lower right-hand corner of book. Figure 30.

"Do you remember the old song, 'I'd rather be on the outside looking in than on the inside looking out?' or something of that kind. That is the reason why when you place a Five Spot inside it comes outside."



With left thumb push up card behind book. Audience cannot see movement of your thumb in pushing card. Be sure to hold book at such an angle that upper rear edge is not visible so that audience cannot see that card does not come from inside of the book. Figure 31.

(19-11)



The illusion from the front is perfect. The audience sees your two hands holding the book closed and the selected card apparently rising from the middle of the book. Figure 32.

Remove card with right hand.

* * * * *

RISING CARDS THROUGH HAT

Another effect with threaded cards -- a bit out of the ordinary.

EFFECT:

Three cards are selected by spectators and replaced in the deck. Deck is thoroughly shuffled and placed in a glass cup. A soft felt hat is now dropped over the cards. The magician commands and the chosen cards rise up one at a time through the hat.

PARAPHERNALIA:

- 1 -- Two decks of cards.
- 2 -- A soft felt hat, especially prepared for Rising Cards.
- 3 -- Fine black silk thread.
- 4 -- A glass cup that will hold a deck of cards. A kitchen measuring cup will do.

MODUS OPERANDI:

(Method of Working)

To Prepare:

Have a card case made of tin, as in Figure 18. Punch a few holes in this case.

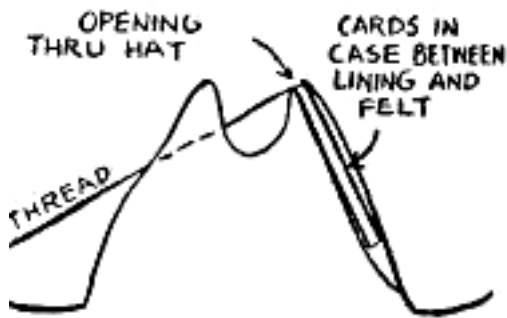


FIG. 33

In one side of the crown of the felt hat, just a little inside of the top edge, cut a hole. Leave the lining intact. Insert the tin case in this opening in hat. Sew around the case to hold it in place between the lining and the hat. Glue the opening around the case. Figure 33.

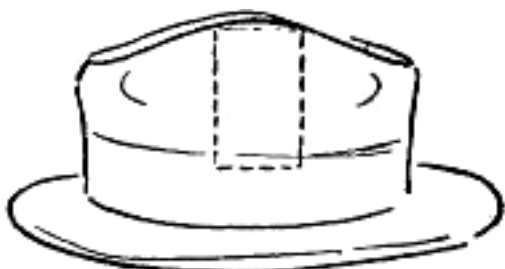


FIG. 34

Figure 34 shows prepared hat. It is placed with prepared side toward audience and nothing unusual is visible. The opening at the top is made inside of the top edge so that it will not be visible from a side view of the hat.

Thread three cards, duplicates of which you are going to FORCE, between four indifferent cards. Place them all in the tin case. Edges of cards should be just a little below edge of case. Thread free end of the thread into a needle. Carry it from top edge of case across dent in crown of hat and through the other side of crown. See Figure 33.

Run the thread off stage to an assistant or make an arrangement whereby you can control pulling of the thread yourself.

To Perform:

FORCE duplicates of the three cards which you have threaded on three different spectators. Have them returned to deck and shuffled in by another spectator.

Place cards in glass cup, facing audience, and place cup on table. Pick up hat at top with left hand, covering opening in hat with palm of hand. Show hat all around without calling verbal attention to same, and especially inside. If carefully prepared, the inside shows nothing unusual.

FRONT



FIG. 35

Drop hat apparently carelessly over the cards and cup. In reality be very careful to set hat down with prepared side straight toward audience. Also be sure that cards in case are facing toward audience. Figure 35.

FRONT



FIG. 36

Have the thread pulled when desired and the three selected cards will apparently rise one at a time right through the hat. Figure 26.

This effect is novel and makes a big hit. I am going to let you write your own patter for this experiment. I am sure you will experience no difficulty in doing so and will find it great fun.

* * * * *

RISING CARDS OUT OF A HAT

This experiment is similar in operation to the effect just described, but the effect is somewhat different.

EFFECT:

Three cards are selected by spectators, returned to pack, and shuffled in. Pack is then dropped into an empty hat. Mysteriously, one by one, the selected cards rise up out of the hat.

PARAPHERNALIA:

- 1 -- Two decks of cards.
- 2 -- Specially prepared hat.
- 3 -- Fine black silk thread.

MODUS OPERANDI:

(Method of Working)

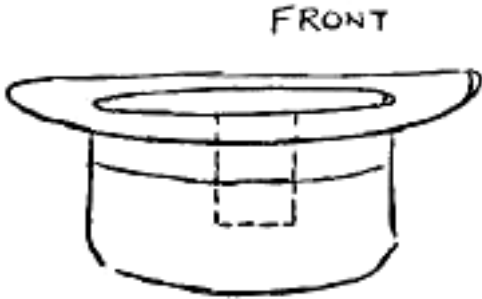


FIG. 37

To Prepare:

Have tin card case made, as in Figure 18. Place this case inside of hat between lining and sweat band on one side. Be sure that opening of case is far enough down beyond edge of hat so that it cannot be seen. Place hat with prepared side straight toward audience. Figure 37.

THREADED CARDS

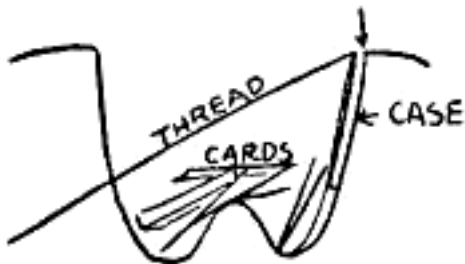


FIG. 38

Select three cards, duplicates of which you are going to force, and thread them between four indifferent cards, as previously explained. Insert cards in the tin case in hat. Draw thread over top edge of case, across inside crown of hat, and through other side of hat. Figure 38.

Pass thread through a staple on floor and off stage to an assistant, or make an arrangement for yourself to control the thread.

To Perform:

FORCE three cards, have them returned to pack and shuffled in.

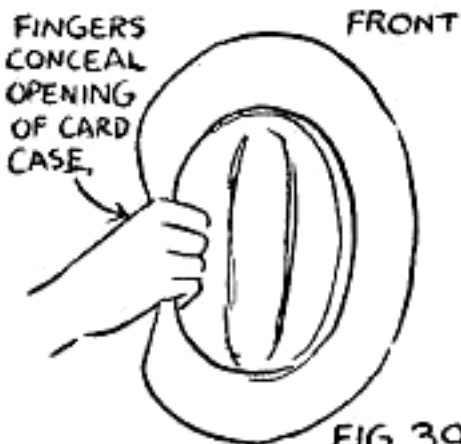


FIG. 39

Pick up hat with fingers over brim at point where case is inserted, thus concealing the arrangement. Show hat empty. Figure 39.

Replace hat on table, opening upward and prepared side squarely in front of audience. Drop the pack of cards into the hat.

FRONT

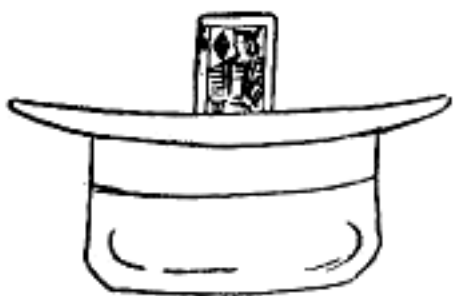


FIG. 40

Have the thread pulled and the selected cards will each rise in turn, apparently right out of the hat from the deck that was dropped there. Figure 40.

Remove each card after it has risen.

You may adapt the Patter which you have written for the previous effect to this one. Or you may write new Patter particularly suited to this experiment.

Remember in writing Patter to put a comedy touch in. This always helps to put the effect over big.

* * * * *

LESSON 20

This lesson marks another milestone in your progress toward becoming a Real Magician. In it you will find invaluable instruction in the Psychology of Successful Magic and material on the Arranging of Programs which will prove to be tremendously helpful.

I also give you two snappy effects, for which I send you

the PARAPHERNALIA:

1 -- Magician shows his wand to be solid. He wraps it in a piece of newspaper and gives it to a spectator to hold. Performer suddenly takes wand, tears paper in which it is wrapped into a number of pieces, and the wand has vanished. It is then produced from the coat pocket.

2 -- King Solomon's Wedding Bands. A comedy experiment, showing how this wise man successfully selected a thousand wives.

We are leaving Card Magic for a while to take up some different angles of Magic. There are more wonderful Card Effects planned for you throughout the course which you will come to later on.

A handwritten signature in cursive script that reads "Harlan Tarbell". The signature is fluid and elegant, with a prominent flourish at the end of the name.

Tarbell System, Inc. Chicago.

(19-15)

LESSON 20

This lesson marks the completion of another ten-lesson period in your progress. You have forged ahead now to your second program lesson. This is, indeed, an accomplishment.

I know from your letters the inspiration and enthusiasm you have felt over your course in Magic, and I know how your interest and desire to learn has grown with each lesson. With such spirit you cannot help but succeed.

I know you yourself have noticed the improvement and development you have made in your mastery of the Great Mystic Art. I know the thrill you feel when you realize that you are learning the great secrets of an Art which no one else, perhaps, in your vicinity knows and that you are becoming skilled in Great Magic.

I need not say again that your investment of time and money in this course will bring returns a hundredfold.

Your friends, no doubt, have been astonished by your exhibition of Magical Power. If you have not felt capable heretofore of giving a performance before an audience, by the time you have reviewed your lessons up to this point and have mastered this lesson, you should feel well able to perform.

Go to the entertainment committees of your club, your lodge, your church, go to the schools in your neighborhood and offer your services. In most cases they will be delighted to have an entertainer whom they can call on. If you feel justified in doing so, charge something for your performance. If not, give your services gratis and you will gain immeasurably in experience and confidence and ability.

With this lesson I send you FREE several valuable pieces of paraphernalia, among which are a regular wand and a vanishing wand. I teach you an effect using the two wands so that you may have an entirely new kind of effect for a new program. I also teach you an interesting cloth band effect.

Before we proceed with the study of these effects and the arrangement of programs, I want to discuss further with you some of the factors in the Psychology of Magic, which you must know thoroughly to be a new type Scientific Magician.

HOW TO PLEASE YOUR AUDIENCE

The Dual Character of the Forces of Life

Everything in life has a dual character -- in every force in life lie the powers for both construction and destruction.

The fire that warms your home can destroy your home. The water that feeds your tissues can drown you. So you see, in the same thing lie the forces for both good and evil.

So it is with your Magic. All depends on whether you use it in a fine, skillful manner, or whether you abuse it and make light of it. Used properly, this great Art can mean tremendous success and happiness for you, but abused, it can mean your downfall.

Your audience, if pleased, will applaud you and heap praises on you and talk about you in a way that may "make" you. The same audience, if displeased with your appearance, your manner, your language, your performance, can hurt you. It is up to you, then, to please your audience. Study how to do this and you need never fear that you will not be successful.

What the Public Wants

People want illusion. They rush to the movies, to the theater, because they want to be entertained in an unreal world, a world of fancy. They want to live in their imaginations for a while and to forget life with its hardships. They find the theater a retreat where they can withdraw from everyday life and see things that are near the ideal.

Artists, writers, producers and actors work to produce the ideal. In the theatrical world all is illusion. There, people live through the troubles and experiences of the characters and find that in the end there is harmony. The lovers fall into each other's arms and live happily ever after. All difficulties are adjusted and everything has a pleasant outcome. The audience is pleased and happy that all is well. Each one has forgotten his own troubles and feels that his affairs will also have an agreeable ending.

This is a great factor in the explanation of the magician's power. He deals with the unreal. His art is so far removed from everyday life that the spell he casts over his public is tremendous. His is a world created entirely of fancy and not fact. He gives the people illusion. And that is what the public wants.

Another thing that the public is intensely interested in is mystery and the supernatural. These will never lose their fascination and, as they are the very stuff of which Magic is made, the Art of the Magician will never fail to hold people spellbound. Magic will never die, and the Magician with his power to produce supposedly supernatural effects will ever continue to thrill the public.

KEEPING UP WITH THE TIMES

Change in the Character of Magic

The character of Magic, like that of everything else in life, has changed with the changing world. At one time a great deal of cumbersome apparatus was used – many trick cases and trunks and long table drapes. The Magician, too, was encumbered with voluminous robes.

Robert-Houdin, whom I have mentioned before as the founder of the modern school of legerdemain, did away with all the gaudy, clumsy paraphernalia of his predecessors. From his time sleight of hand came into its own and this, of

course, does not require much paraphernalia. Many Magicians acquired great skill in manipulating small objects, such as coins and cards, and made a great success of it. T. Nelson Downs is a King of Coins in the magic world. Manuel is another clever coin expert. There was a craze at one time for coin acts in imitation of Downs. Special acts were also built around the use of cards. Howard Thurston was once famous for his card act.

This was the beginning of the development of impromptu and vest-pocket Magic, which of recent years has come into such popularity. The demand for Magicians to perform at clubs, in homes, at social functions, has required the further development of this type of Magic. In such cases the performer cannot have an elaborate preliminary set-up. This has necessitated the simplification of apparatus and the creation of effects which permit the use of paraphernalia which the Magician can carry about with him and for which he can use ordinary objects.

This simplification of paraphernalia and of effects has made the Art of Magic even more astonishing by reason of its impromptu and apparently makeshift nature.

This type of work has developed the suit case act, where the properties are carried in a suit case and are taken out and replaced as necessary. (See Lesson 10, How to Present a Program.) At such a performance the Magician is ready for work when he opens the suit case and has completed his act when he closes it.

The important thing in Modern Magic is not necessarily elaborateness, but novelty, surprise, something spontaneous and effective; and that is what the Modern Magician must give.

Individuality You Display Must be Suited to the Times

This brings us back again to a discussion of Individuality – an Individuality suited to the times. Robert-Houdin was the first Magician to discard the old clumsy robes and to appear in a dress suit. He did the Art a good turn by making departure from the old order. Since his time, however, many performers have worn full dress, and not with such good effect. On the stage with a full evening show a la Thurston or Houdini, the dress suit is permissible, providing the performer is the type that can wear one. In view of the change in style, you are much safer in appearing in a Tuxedo for dress wear, thus avoiding any possibility of friction with the audience. For the informal performance the business suit will do very well. There is no need for you to try to display individuality in dress or appearance until you know just what you will accomplish thereby, and whether it is of positive benefit to you.

Take mustaches, for instance. At one time there was a craze for Magicians to wear mustaches and goatees. It arose through imitation of a hero, the usual foundation for fads. This hero was Alexander Herrmann – Herrmann the Great. This great magician wore a mustache and a goatee. They enhanced

his appearance and were well suited to him and gave him individuality. Those who imitated him, however, must have in many cases appeared ridiculous. Today we have Laurant, LeRoy, and Brush who wear distinctive looking mustaches and with effect. However, there are some would-be magicians who feel that they must have mustaches, regardless of suitability, to make them individual and great magicians. If these fellows don't grow them, they paste on big black mustaches and utterly disregard their complexions and color of their hair with the result that they present a ludicrous figure.

Set Your Stage in Keeping With the Times

Dealers in magical supplies have greatly influenced the stage settings of magicians, particularly of novices in the field. The dealers sell certain stock sets and apparatus. The result is that there has been too much sameness in stage settings. When the curtain rose or parted, there stood the old familiar magic tables, the same apparatus. This has grown very monotonous and uninteresting to the audience.

Other magicians went to the other extreme of too much display and gaudiness in striving for individuality. The pendulum is now swinging back again, however, to simplification of stage settings with better effect. It is not necessary to overdo special costumes and gorgeous scenery in these times. People like simplicity with artistic effect. You may make your stage setting colorful and unique, if you like, but keep it simple. Do not use old, cheap looking effects in your settings, and remember always to suit the occasion and the audience. Let good taste and modernism guide you.

MAKING AN IMPRESSION

How to Make Your Appearance.

The first impression which your audience forms of you is very important in your future success. You must, of course, be very careful of your magical properties. They must be kept in good condition so that they will be attractive and convey the impression that you have high standards in your work.

As to your personal appearance, I believe it is unnecessary for me to reiterate that you must be neat and careful about your clothes, your hands, your hair.

When you enter, walk in briskly. Do not shuffle along unless you are doing a comedy act and do it for effect. Walk directly to the center of the stage without looking at your audience. Do not bow and scrape and nod as you come in. Do not notice people until you are at the center of the stage. Then turn and face your audience and direct your attention to them. If you are to perform at a dinner or some other special occasion, do not get the attention of the guests until the time for your performance arrives. Only at this psychological moment must you make the audience notice you and keep their attention focused on you until you are through.

Always study your opening very carefully, for remember, you will sell yourself or harm yourself at the first moment of your performance.

Excercise Magnetism on Your Audience.

Keep your eyes! on your audience most of the time. Talk directly to them. Now and then for effect you may pick out one or more spectators and direct your attention to them. Talk convincingly to them and impress them, and you will find that this is a means of impressing everyone in that audience.

Talk distinctly and convincingly. Talk loud enough for every one to hear you and give enough force to your words to send them straight to the mark. Be careful of your language. Use judgment in what you say, and above all, speak correctly. Put expression into your voice and face -- avoid a monotone and a blank look. Put LIFE into your performance.

Create Interest in Your Spectators.

Your problem is to arouse and to hold the interest of your audience. Be snappy in your work and your audience will be interested in watching you. If you give a slow, long-drawn out program your spectators will fall asleep -- and that spells tragedy. You must not, of course, go to the opposite extreme and work so fast that your audience cannot follow you.

The next factor in creating and holding interest is attention to what the public demand is -- what they want you to give them. The wise magician, just like the wise merchant, studies the trend of the times and the kind of things people are clamoring for. He then capitalizes on this. He presents to the people the things they want and are willing to pay for and presents them in attractive packages, that is, in a pleasing form.

Study your program from the standpoint of the particular occasion and the particular audience. Try in your effects and in your "Patter" to come within the experiences of your spectators. Do not do things and say things that are absolutely foreign to their own lives and that they will not understand. Enter into their own lives and their own knowledge a little and they will give you their understanding and appreciation. You will then have their interest and the success of your performance is assured.

* * * * *

MAINTAIN A HEALTHY ATTITUDE TOWARD MAGIC

You know from your own experience that it is always the unsuccessful fellow or the one who bears a grudge who is a knocker. So it is in Magic. The man who has made no mark in the profession or the man who is an out and out failure is the one who says that Magic is dead. That man sticks to the same old hackneyed program; he dresses the way magicians did years ago; his patter is stupid; and even his work is so poorly done that school boys ridicule him. His language is improper. He irritates his audiences instead of pleasing them. And then he goes about knocking Magic. His outlook is not healthy and he will never succeed until he wakes up and changes his attitude.

(20-5)

The man who knocks Magic has not had the proper foundation. He does not know the principles of Magic. He does not understand Magic as a Science. He does not know the proper way to present his effects. He does not know SHOWMANSHIP. He has not the slightest conception of the psychological nature of his work. How, then, can he succeed? He knows something is wrong and it does not occur to him to look within himself for the difficulty. No. Instead he knocks his profession.

You never hear the successful Magician knocking Magic. He finds it tremendously ALIVE and full of opportunity and big financial return. He is well known and admired. He is in demand. He will not discourage you for he has gained success and knows that you can. He is a BOOSTER. He, perhaps, has been discouraged himself many times by the knocker, but determination led him on until he reached the goal of the GREAT.

You must not let the knocker discourage you or plant any doubts in your mind if he should come your way. You know that you stand head and shoulders above him with your SCIENTIFIC TRAINING in MAGIC. You are enthusiastic and inspired, you are enjoying a rare opportunity in studying this course. Let nothing dampen your spirits. Keep your outlook healthy and you are bound to succeed.

* * * * *

We come now to the new effects in this lesson. They are easy to perform but permit of excellent SHOWMANSHIP.

THE VANISHING WAND

A good effect with which to open a program.

EFFECT:

Performer, after tapping his wand on the table to prove that it is solid, wraps it in a piece of paper and gives it to a spectator to hold. Magician then suddenly grasps the wrapped wand and tears it to pieces. Mysteriously the wand has disappeared. Now, however, magician reaches into his inside coat pocket and produces the solid wand again and proceeds with it throughout his performance.

PARAPHERNALIA:

1--A regular wand - sent you FREE with this lesson.

2--A vanishing wand.

This is apparently solid like the regular wand, but in reality it is made of a paper shell with solid ends.

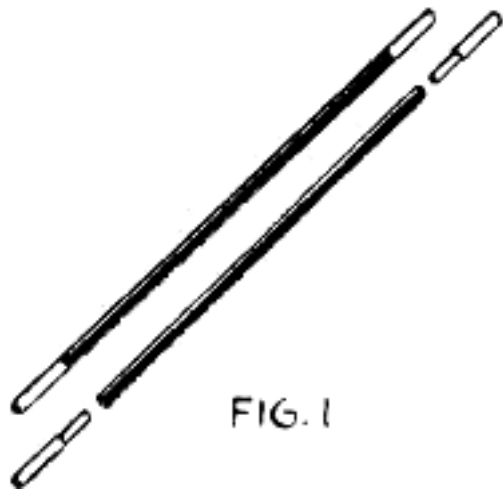
This is also sent you FREE with this lesson, including a few extra paper shells.

3--A piece of newspaper, about 17 inches square.

SECRET AND PATTERN:

To Prepare:

Note how the special vanishing wand is made. It is a black paper shell with wooden plugs which fit into each end. Place this wand alongside of the regular wand and you will find them very similar in appearance. Figure 1.



Because of the solid ends on the special wand, it can be tapped on the table and shown apparently to be solid. Even if it is dropped on the floor, it sounds as though it were solid and a regular wand.

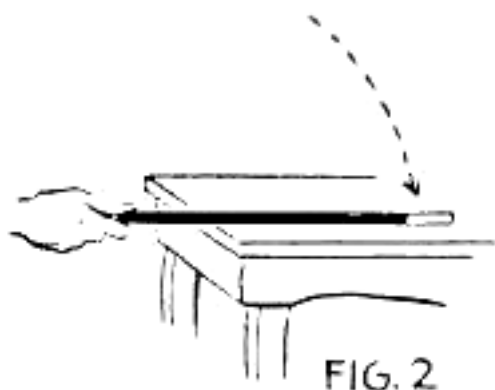
Have wand and paper on table, or if you choose, you may enter with special wand in your hands.

Tuck the solid wand away beforehand in your inside coat pocket. Push the upper end back under pit of right arm so that there will be no danger of exposure. Better still, make a long narrow pocket for the wand to fit into. To do this, just sew a piece of black cloth of the proper size inside of your coat.

To Perform:

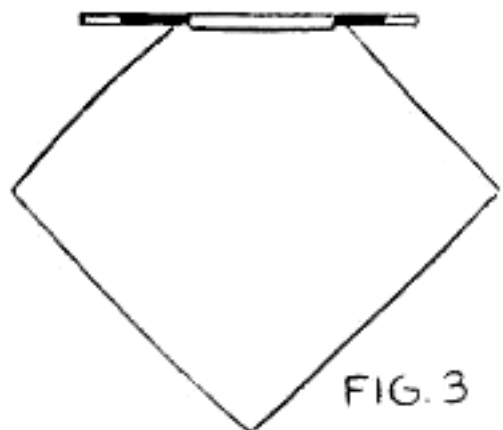
Have special wand in your hands.

"For years the Hindu Magician has been known for his baffling experiments in Magic. Tourists have come from all over the world to see the mysteries of this ingenious mystifier. No spectator has ever discovered any of his profound secrets. One experiment which the Hindu does is a particularly interesting one. He takes a small stick or twig from a tree. My wand will answer the purpose here for it is a piece of ebony wood tipped with ivory."



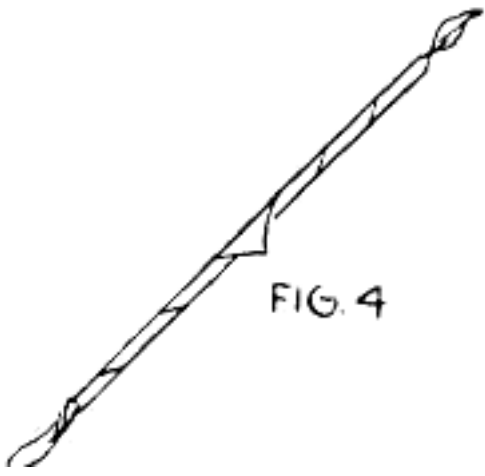
Tap wand on table two or three times to show that it is solid. Be sure to tap the wooden ends and not the paper shell for this may tear over the end of the table. Figure 2.

"He usually passes the stick around among the spectators, and then, picking up a piece of paper, wraps the wand carefully in it."



Take piece of paper and wrap wand in it. Start at one corner and roll the wand up diagonally across the paper. This keeps the wand within sight of the audience until it is completely wrapped. Figure 3.

"Then he twists the paper tightly at each end so there is no chance for escape."



Twist the paper about each end of the special wand. The paper now completely covers the wand. The audience knows that it is there, however, for they saw you actually wrap it up. Figure 4.

(20-7)

"Then he gives the wrapped stick to some spectator to hold. Will you sir. please hold this wand?"



Give wrapped wand to spectator. Have him hold the wand vertically with his right hand at the bottom wooden end and his left hand at the top wooden end. Figure 5.

"You feel the stick, do you not? Wood is pretty solid, and if you are feeling well at all -- which you seem to be -- it isn't difficult to detect. Perhaps you had better just stand up so that all of the audience can see."

Have gentleman arise and hold wand in same position so that all can see.

"Suddenly the Hindu reaches over and grasps the paper."

Suit the action to the word. Reach over and take wrapped wand from gentleman.

"He says, 'Hi-Hi,' and tears it into pieces."

Tear paper through the middle. Then place the two halves together and tear them through again. Crumple up the paper into a ball and throw it aside or drop it on the table.

The tearing of the wand is not difficult. The wooden ends are small and are not noticed when the paper is crumpled up. Be careful that no one gets hold of the paper to examine it. Always destroy your evidence as soon as possible.

"The gentleman here wants to know what became of the stick. I shall explain it. Do you remember when I said, 'Hi - Hi'? That was the signal for the stick to jump."



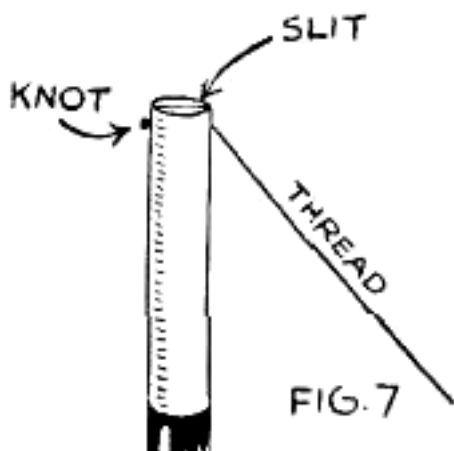
Reach in and take regular wand from inside right coat pocket with left hand. Flourish the wand around and show it to audience. Figure 6.

"And here it is in my inside pocket."

SUGGESTIONS:

The principle of the vanishing and reproduction of a wand permits of many variations.

For quick action the performer wraps wand in paper after showing it to be solid and tears it up immediately without giving it to an assistant to hold.



Another interesting way to produce a wand is to get an opaque flower vase and place it on the table. Make a little slit in one end of the wand into which insert the end of a piece of thread. Knot the free end of thread so that it will not pull out. Figure 7.

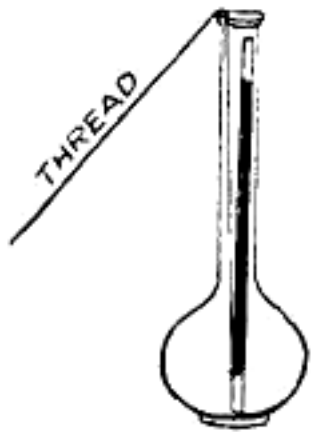


FIG. 8

Drop wand, prepared end downward, into the vase. Vase should be high enough to cover wand when it is inside. Now run thread over to back of table and tie to a tack or staple, as you did in rising card experiments. Figure 8.



FIG. 9

Pick up vase in left hand and bring it forward. The tightening of the thread will cause the wand to rise up out of the vase. Grasp wand with right hand before it topples over. It will pull away from thread easily. Figure 9.

If an assistant is available, run the free end of the thread out to him in the wings offstage. You need not touch the vase, then, but have him cause the wand to arise by pulling the thread.

* * * * *

KING SOLOMON'S MARRIAGE BANDS

This is a modification for practical use of the old Afghan Bands. It is an age-old principle brought up to date.

There is a touch of comedy in this effect and because of its nature, it is adapted to mixed audiences made up of a group of young people of the marriageable age.

EFFECT:

Performer shows a band of bright red cloth. He tears it in two, thus forming two separate rings. One of these rings is torn in two parts and instead of forming two rings, the two bands are found to be linked together. The other half of the original band is torn in half and the surprising result is one large band instead of two separate bands.

PARAPHERNALIA:

1 -- A strip of bright red percale --one yard long and four inches wide.

SECRET AND PATTERN:

To Prepare:

Get a yard of percale and make up a few of these bands. Percale comes in yard width. One yard will make nine bands. The material tears crosswise very easily and you will find no difficulty in tearing it into four-inch bands.

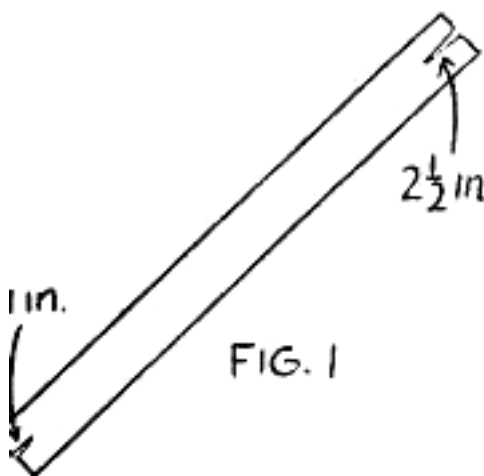
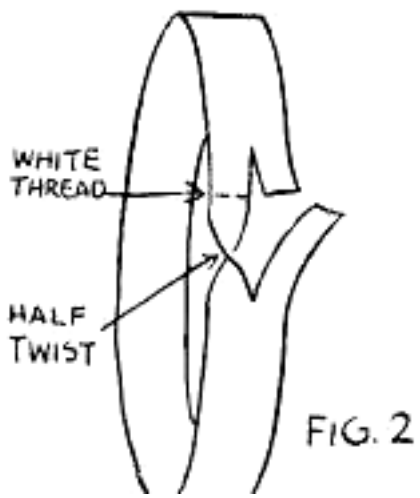


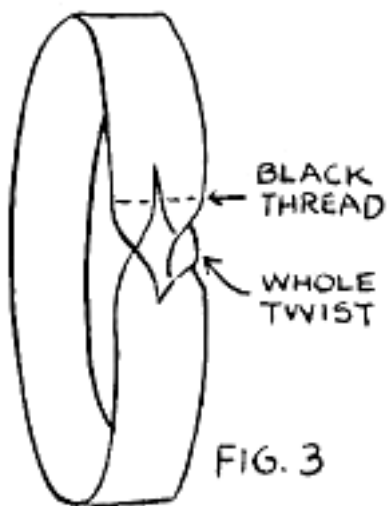
FIG. 1

Take one four-inch band. With a pair of sharp scissors cut a slit two and a half inches long in one end and one inch long in the other. Figure 1.

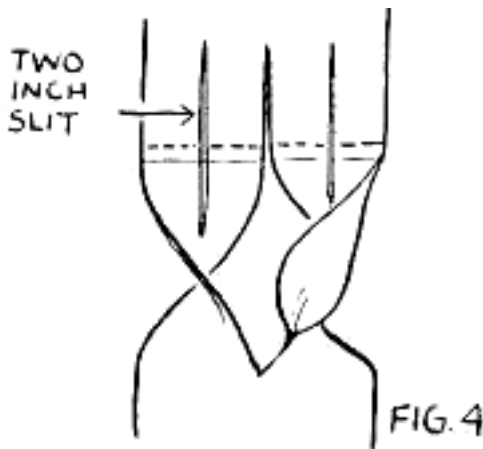


Bring the two ends of the band together. Take lower left-hand end of strip and give it a half twist. Sew it to upper left-hand strip with white thread. By doing this, you bring the inside of the cloth at one end against the outside of the cloth at the other end. Figure 2.

(20-9)



Take the lower right-hand end and give it a whole twist. Sew this end to the upper right-hand end with black thread. This whole twist brings the outside of the cloth right back again to outside of the upper end. Figure 3.



Through each of the two sewed sections of the band cut a slit about two and a half inches long. Figure 4.

Fold up the band with faked ends inside. Have ready on table.

To Perform:

Pick up folded band from table and hold it in left hand.

"It is said that King Solomon was a very wise man -- so wise that he was able to keep peace among one thousand wives. Men in this day and age wonder how in the world he did it. I have discovered the secret -- not from King Solomon himself for I never knew the gentleman personally -- but in a roundabout way from a friend whose great great grandfather's great great grandfather was personal magician to the King and thus he got the inside information. It seems that the King knew how to pick 'em. Before he married each time of the thousand times, he brought out his magic marriage band."



Unfold the band, taking care to keep the prepared side at the back and away from the audience. Hold band over left hand as in Figure 5.

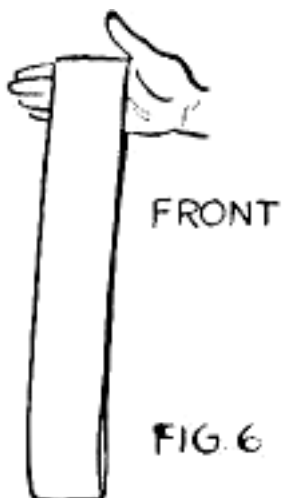
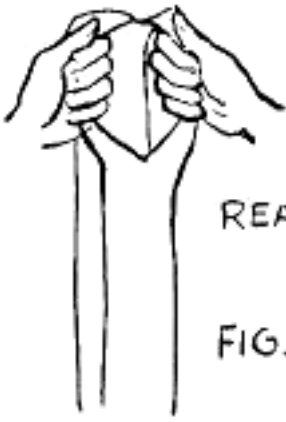


Figure 6 shows front view. Band appears to be ordinary to the audience.

"This is one of them -- a strip of red cloth made in the shape of a circle. He would tear the circle apart."



REAR

FIG. 7

Grasp band through large slit in middle, one hand holding each side of the band. Pull sideways in opposite directions, tearing the band until it is torn through into two separate bands. Figure 7.

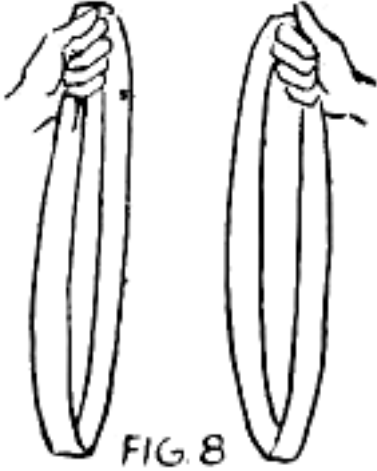


FIG. 8

Hold one band in each hand with prepared joining covered by palms of hands. Figure 8.

(20-10)

"And when it tore into two separate rings, he knew that the young lady before him was not in harmony with him and that their lives were too far apart."

Let the ring that is sewed with white thread hang over your left arm and take the ring that is sewed with black thread in your right hand.

"Perhaps the band, however, when it was torn formed two bands, one linked in the other."



FIG. 9

Insert fingers of both hands into slit in this band and pull apart until band is torn all the way around. The result will be one band linked in another, caused by the half twist which you made in joining the band. Figure 9.

"This was better – while they moved in separate circles. they were linked together in other respects."

Drop linked bands on table. Take other band from left arm and put fingers in slit in readiness for tearing.

"Then came the real test."



FIG 10

Tear band all the way around. The result will be one large band instead of the two that one would expect; caused by the whole twist which you made when joining this band. Figure 10.

"He tore the band again and it became one large band. He knew then that the young lady and he were in harmony and were joined together as one. So they were married and lived happily together ever after."

* * * * *

ARRANGEMENT OF PROGRAMS

The big idea in arrangement of programs is to get the interest of the audience, to hold their interest, and to make a lasting impression.

I have already discussed with you the importance of getting the interest of your audience. This puts the audience into a receptive mood and establishes a pleasant connection between performer and audience. Then the effects must progress to keep the audience keyed up until you reach your last effect – your masterpiece. Your finishing number must be so good that it wins an outburst of spontaneous applause from every member of your audience. As to what your masterpieces or finishing numbers will be, I cannot say. They depend on your personality and your likes. You can judge for yourself what effects are fitted to you and which you will make a big success with.

Have VARIETY in your programs. Inject plenty of comedy touches to break the tension of seriousness. You must get the contrast between seriousness and fun into your programs. Keep your audience in a wave of emotion -- now laughing, now tense, then laughing again. In this way, you avoid being monotonous and tiresome, by not overdoing

the humorous or overemphasizing the serious. Then with your last effect, make an impression that will hold. Leave your audience talking about you.

These programs which I have arranged for you are for Club or Parlor work or any occasion which demands the smaller program. While they may be used also for Stage work, they are particularly adapted to the less formal presentation.

I.

- 1 -- The Vanishing Wand (Lesson 20)
- 2 -- Chinese Paper Tearing (Lesson 4)
- 3 -- Producing a Card from a Whole Orange (Lesson 14)
- 4 -- The Bewitched Banana (Lesson 14)
- 5 -- King Solomon's Wedding Band (Lesson 20)
- 6 -- Cards That Pass in the Night (Lesson 12)
- * -- For an Encore -- Cards Up the Sleeve (Lesson 13)

II.

- 1 -- The Vanishing Wand (Lesson 20)
- 2 -- Mystery of the Traveling Numbers (Lesson 8)
- 3 -- Snap It. (Lesson 17)
- 4 -- Mystery of the Glass House (Lesson 17)
- 5 -- Rising Card Escape (Lesson 9)
- 6 -- The Card and the Banana (Lesson 14)
- 7 -- Three Cards Through the Handkerchief (Lesson 16)
- 8 -- Japanese Thumb Tie (Lesson 11)

III.

- 1 -- King Solomon's Marriage Band (Lesson 20)
- 2 -- Vanishing Cigarette in Handkerchief (Lesson 2)
- 3 -- "Tack It" (Lesson 16)
- 4 -- Card Through the Handkerchief (Lesson 16)
- 5 -- Rising Cards in Glass, (Lessons 18
Or Any Other Rising Card Effect 19)
- 6 -- Mystery of the Glass House (Lesson 17)
- 7 -- Cards That Pass in the Night (Lesson 12)

I WANT TO HEAR FROM YOU

I am intensely interested in how you are progressing with your studies, and I am very eager to know whether you have begun to perform.

I have received enthusiastic letters from some of you, and I want to hear from others. Perhaps those who have not written are too busy with their studies and their Magic shows to spend time writing. If that's the case, it pleases me greatly. However, I should appreciate hearing of the success of my students and wish the busy ones would make a special effort now to write their teacher the good news.

Tarbell System Incorporated, Chicago.

Lesson 21

This lesson gives you your foundation for SLEIGHT OF HAND WITH COINS. This starts you on an entirely new group of principles in your study of the great art of Sleight of Hand and teaches you a great many important coin manipulations.

LESSON 21

SLEIGHT OF HAND WITH COINS

You have now reached the stage where you are ready for sleights with coins. This field of coin manipulation is a vast one and a thorough knowledge of it will add much to your Magical Education. Other small objects may be handled in a manner similar to coin sleights. Consequently when you have mastered the manipulations in this lesson you have proceeded a long way in your mastery of Sleight of Hand.

T. Nelson Downs is a King of Coins. He built a great reputation by specializing in Coin Magic, and at one time his act was imitated more than any other in the realm of Magic. Who will forget his famous Miser's Dream in which coin after coin was plucked from the air and dropped with a jingle into a borrowed hat? I do so wish that every one of my students could see this expert coin manipulator at work.

Another expert in coin manipulations is Manuel, Master of the Mighty Dollar, as he styles himself. His work is a revelation in coin sleights.

I teach you a great many principles of coin sleights in this lesson. This is to give you a firm foundation in the art.

Practice well and MASTER every movement I give you and your reward will be a variety of methods at your command for vanishing and appearing a coin or other small object.

Many of these principles are very simple in operation; others I have analyzed and simplified to such an extent that careful study of the illustrations will enable you to learn them without difficulty. I have illustrated this lesson so profusely that there need be no doubt about any move.

The fundamentals of Magic which are very important in these manipulations are:

Angles of Visibility

Naturalness

Misdirection

Stand before your mirror and watch your reflection closely so that you learn to do these manipulations correctly.

* * * * *

The first thing for you to do is to review the section on the ART OF MISDIRECTION in LESSON 3. This is absolutely essential as your beginning in learning coin sleights.

There are many types of hands and some methods of manipulation lend themselves better to one type than to another. Practice them all, however, and then you can discover for yourself to which methods your hands are best adapted.

The most popular coin for general use is the half dollar. Start with a coin that has a fairly good milled edge. I send you FREE for this lesson three Palming Coins. You will find them fine for manipulation work as the edges are well milled and permit of a firm grip. I advise you to purchase about 2 dozen of these coins as you will find them invaluable in future coin tricks. We can supply you with them at \$1.00 a dozen.

PALMING USED IN COIN SLEIGHTS

1 -- Front Flat Palm.

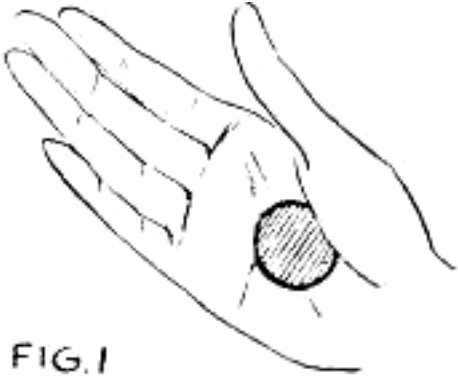


FIG. 1

This is the ordinary palm in which the coin is held flat against the palm. Slight pressure of the fleshy part of the base of thumb and third and fourth fingers holds the coin. The fingers should be slightly curled and the whole hand must be held in an easy, natural position. Avoid any awkward movement of trying to stretch the fingers and thumb outward. Figure 1.

2 -- Pressure Palm.

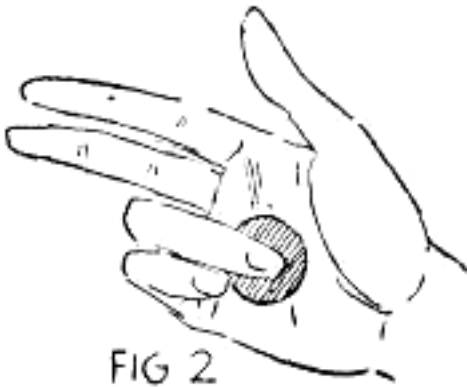


FIG 2

This is a very easy way of concealing a coin. The coin is placed flat against the palm as in the Front Flat Palm, but in this method the third finger tip holds it against palm of hand. Figure 2.



FIG 3

You can hold your hand in a perfectly natural manner in using this method. The third and fourth fingers curl under and the thumb and first two fingers are straight. Figure 3 shows hand as it looks to audience.

3 -- Front Edge Palm.

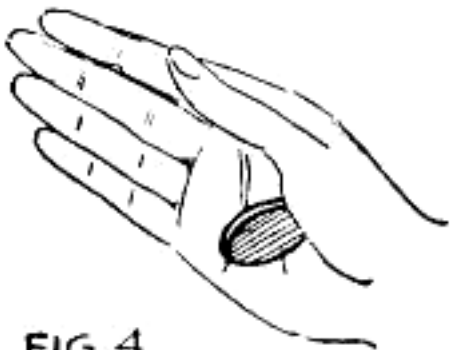


FIG. 4

Coin is palmed by its edge. It is held in a slanting position between the fleshy base of thumb and base of fourth finger. Figure 4.

4 -- Front Thumb Palm.

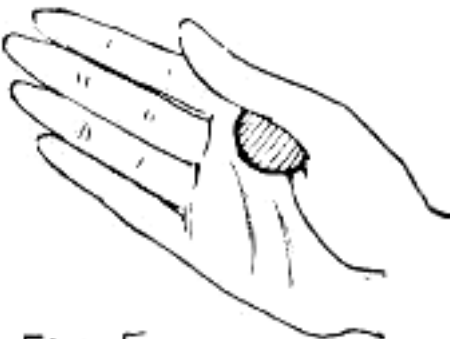


FIG. 5

Very convenient to use. Coin is held between thumb and base of first finger. Care must be taken that coin is well inside of the hand and does not show from back of hand. Figure 5.

5 -- Back Thumb Palm.

Coin is held in crotch of thumb and first finger. Coin is at back of hand so that palm of hand can be shown freely without detection. Figure 6.

(21-2)

FIG.6



6 -- Invisible Thumb Palm.

This palm is excellent for you can show both sides of hand and yet have the coin concealed.



FIG. 7

Coin is held in a horizontal position between base of first finger and thumb. First joint is turned downward slightly. Figure 7.



FIG. 8A

Figure 8A shows view from above.



FIG. 8B

Figure 8B shows hand as it looks to audience. You may show front and back without having anyone detect the concealed coin.

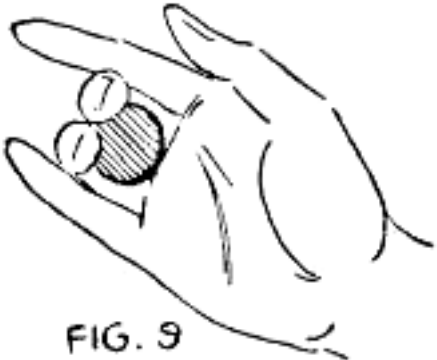


FIG. 9

7 -- Finger Palm.

You learned this palm in Lesson 1. Coin is held at third joint of second and third fingers. These two fingers are slightly curved to hold it securely. Rest of fingers are held naturally. Figure 9.



FIG. 10

8 -- Curled Finger Tip Palm.

This is also a simple palm in which coin is held between second and third fingers near the tips. The fingers are curled into the palm with other fingers held naturally. This method is very useful in change-over palming from one hand to another. Figure 10.



FIG. 11

9 -- Front Finger Palm.

Coin rests flat on second and third fingers over the second joints. On each side the coin is gripped by the first joints of both first and little fingers. If second and third fingers are moved away, coin must still be gripped by other two fingers. Figure 11.

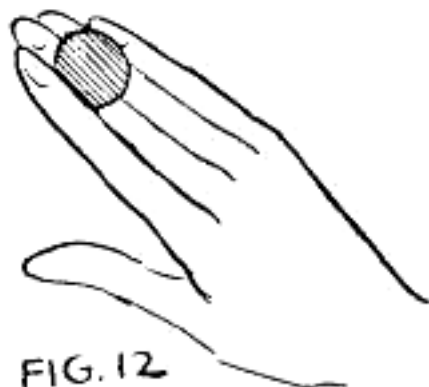


FIG. 12

10 -- Back Finger Palm.

Similar to palm described above except that coin is held on back of hand. It rests flat over second joints of second and third fingers and is gripped on its edges by first and little fingers. Figure 12.

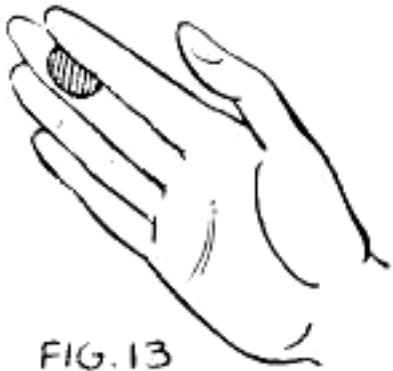


FIG.13

11 -- Front Finger Clip.

Coin is gripped securely between first and second joints of first and second fingers with the coin toward palm of hand. It must not be seen from back of hand. Figure 13.



FIG.14

12 -- Back Finger Clip.

Similar to Front Finger Clip, except that coin is held to back of hand. It must not be visible from front of hand. Figure 14.

(21-3)



FIG. 15

13 -- Closed Finger Palm.

Coin is held in place by being gripped in second joint of third finger and crease in palm as hand is partially closed. Other fingers are held naturally. Figure 15.

* * * * *

The thirteen methods of palming described above cover those used in the ordinary realm of coin sleights for concealing and producing coins.

Now we proceed to methods of holding coins while they are visible to audience.

HOLDS USED IN COIN SLEIGHTS

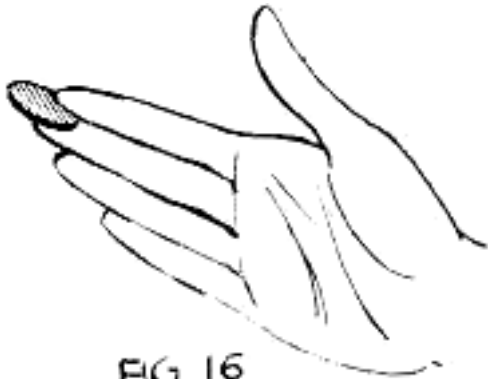


FIG. 16

1 -- Finger Tip Clip.

Hold coin at tips of fingers so that as much of coin as possible is visible, yet with enough between fingers to permit you to grip it securely. Figure 16.



FIG. 17

2 -- Two Finger Balance.

Balance coin at tips of any two fingers next to each other. Figure 17.

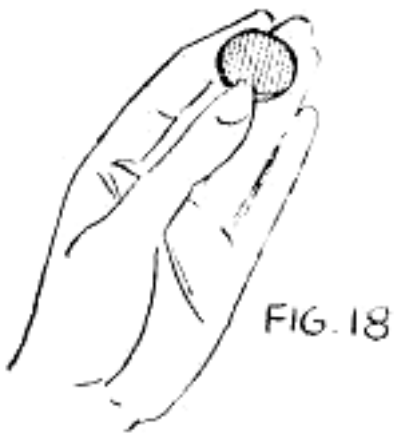


FIG. 18

3 -- Thumb-Fingertip Horizontal Hold.

Grip coin in a horizontal position at tips of thumb and first three fingers. Figure 18.

4 -- Thumb-Fingertip Vertical Hold.

Hold coin in vertical position between tips of thumb and first two fingers.

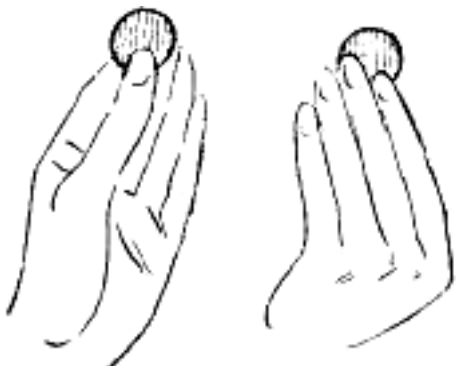


FIG. 19

FIG. 20

Figure 19 shows view away from audience and toward performer.

Figure 20 shows hand and coin as seen by audience.

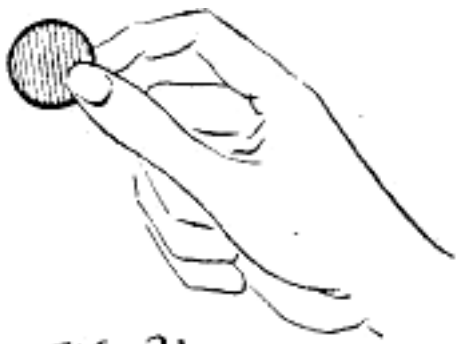


FIG. 21

5 -- Production Clip.

This is an excellent hold for production of coins in the "Miser's Dream" and other coin productions. Hold coin between tips of thumb and index finger. Practice letting coin come from various holds and palms to this Production Clip. Figure 21.

(21-4)



FIG. 22

6 -- Pinch Clip.

Hold coin by edges between tips of thumb and first finger. Figure 22.

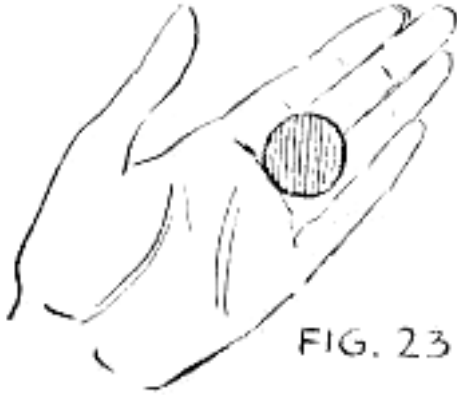
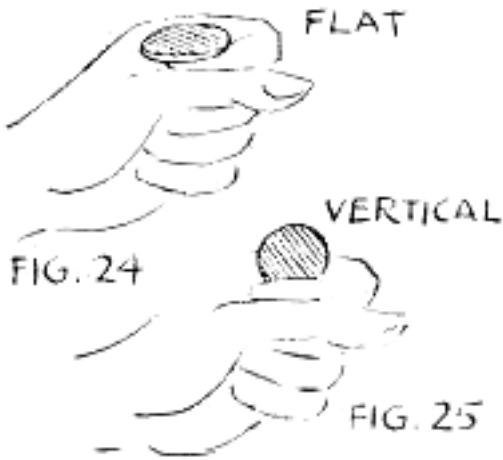


FIG. 23

7 -- Flat Finger Position.

Hold coin flat on two middle fingers, near the base as shown in Figure 23.



FLAT

VERTICAL

FIG. 24

FIG. 25

8 -- Fist Horizontal and Fist Vertical Holds.

Lay coin flat on top of closed hand over the thumb and first finger. Figure 24.

Clip coin vertically into curled index finger with fist closed. Figure 25.

To vanish coin pretend to pick it up with right fingertips. When covered by fingers let coin drop into closed left hand. Carry right hand away as though containing coin. Open hand and show coin has vanished.

MANIPULATIVE METHODS FOR VANISHING A COIN



FIG 26

1 -- Front Thumb Palm Vanish.

Have coin in Finger Tip Clip position in right hand. Figure 26.



FIG 27

Pretend to throw coin into open left hand, but as right hand makes motion of throwing towards left hand, curve the first and second fingers with coin inward to crotch of thumb. Figure 27.

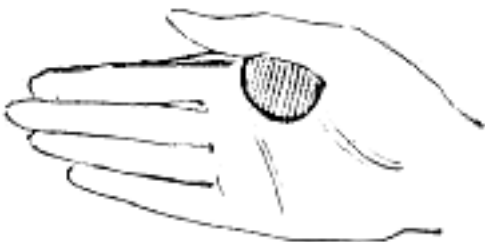


FIG. 28

Close thumb against coin until it is held in regular Front Thumb Palm position. When coin is secure, fingers, of course, are straightened out. Figure 28.

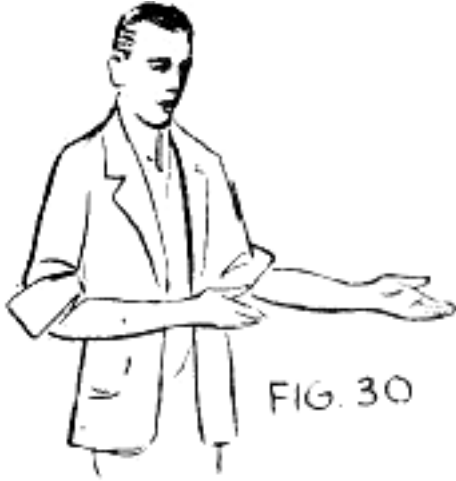


Right hand continues its movement without a noticeable pause and goes to left hand, which should be quickly closed about it. Figure 29.

(21-5)

To the audience it appears that you have actually placed coin in left hand. Withdraw right hand, still holding coin, and open left hand to show that coin has disappeared. Beware of sudden jerky moves. Be graceful. Put "class" into your manipulations.

2 -- Top Pocket Vanish.



This is a continuation of the above vanish. When coin is apparently placed in left hand and hand closed about it, left arm is raised above the level of the waistline. Right arm is, of course, brought on a level with left. Figure 30.

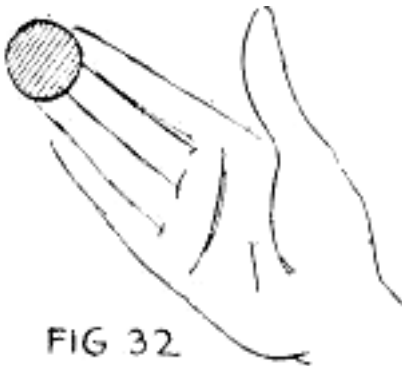


Right hand should be brought just above the left top pocket in your coat. You will find it very easy to drop the coin in that pocket. Figure 31. Be sure to keep your eyes on your left hand.

Lower right hand slightly then. Now left hand is opened again and shown empty and right hand may also be shown empty. Some performers sew a piece of stiffening to upper edge of pocket to keep it open and easy to get things into.

PERFECT THE MOVE OF OPENING THE HAND TO SHOW THAT COIN HAS VANISHED. You must put showmanship into this. Open your hand slowly and gracefully. The hand must never be opened suddenly except in a throwing motion or some special action that requires it. Study this move to give it finish.

Let me say again -- practice before a mirror and do each sleight just as you would if you were actually placing the coin in the left hand. Remember NOT to look at the opposite end of your effect. Do the moves NATURALLY.



3 -- Front Flat Palm Vanish.

Use the Two Finger Balance for holding coin and showing it to audience. Figure 32.



As you turn hand over and bring it toward left hand, apparently to place coin in left hand, bend your second and third fingers inward to palm of hand. Figure 33.

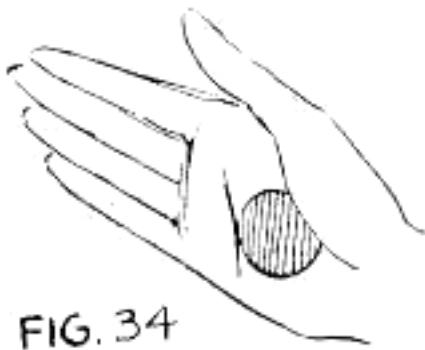


FIG. 34

Press coin into palm of hand and then straighten fingers. Coin is now held by the Front Flat Palm method. Audience thinks you have placed coin in left hand and are not aware that you have it concealed in right hand. Figure 34.

In each Vanish, you continue movement of right hand toward left, of course, after you have vanished the coin into your right hand. You pretend to close left hand over coin and open right hand. Then open left hand slowly and show that coin has disappeared.

(21-6)

4 -- Front Finger Palm Vanish.

Hold coin in Front Finger Palm position in right hand. Show coin plainly to audience, holding both hands out toward them. Figure 35.



Turn right hand over into left hand as if to drop coin there. Figure 36. Remove right hand with coin still Front Finger Palmed. Then curl third finger inward and conceal coin by the Closed Finger Palm method (Figure 15). This method makes it natural for you to point at left hand with right index finger. Open left hand and coin is gone.



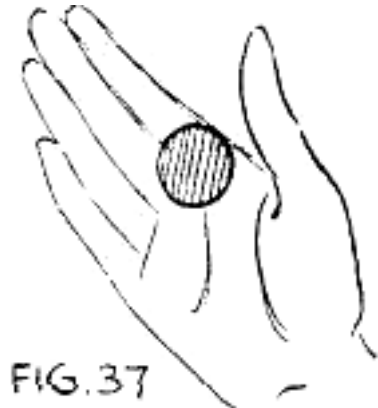
A modification of this Vanish may be made in this way:

Start with the coin in the center of right palm. Slant fingers downward slightly so that coin slides down to the position for the Front Finger Palm. Grip coin there and turn hand over, bringing it toward left hand. Then continue as in the regular Front Finger Palm Vanish.

The effect to the audience is that the coin continued to slide from the right hand into the left. Do not hesitate in turning of right hand toward left and the illusion is perfect.

5 -- Thumb Grip Vanish.

Hold coin in position at base of first finger of right hand. Show to audience in this position. Figure 37.



Turn hand over toward left as though to let coin fall into left hand. As hand turns, hold coin in place with right thumb. Figure 38.



Right hand continues over to left hand. Close fingers of left hand around it apparently to take coin. Remove right hand and completely close left hand. Figure 39.





Open left hand slowly to show it empty with the coin gone. Figure 40.

Remember NEVER TO LOOK AT THE HAND WHICH CONCEALS THE COIN but look at the other hand and the eyes of the audience will follow yours -- simple misdirection.

(21-7)

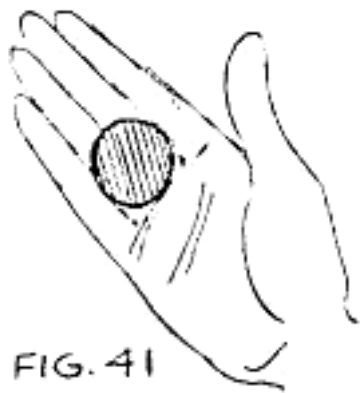


FIG. 41

6 -- Finger Palm Vanish.

This is another simple natural vanish. Hold coin in Flat Finger Position (Figure 23) as shown in Figure 41.



FIG 42

As you turn hand over toward left, curl under your second, third, and fourth fingers to grip coin and palm it in regular Finger Palm style. Figure 42.

Coin is apparently thrown into left hand, which closes about it at the right moment. Then hand is opened and coin has disappeared.

7 -- Lift Up Vanish.

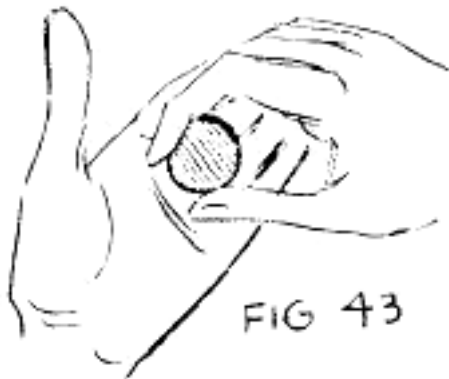


FIG 43

Place coin in left hand in Flat Finger Position and show it freely to audience. Figure 43.



FIG. 44

Reach down with right hand, apparently picking up coin. Just as you pretend to lift coin, turn left hand slightly toward your body so that coin is concealed from audience. Finger Palm coin in left hand and point index finger at right hand, which continues upward in its movement of pretending to carry coin away. Figure 44.



FIG 45

Figure 45 shows you the effect to the audience. The movement is so natural that they do not suspect that you do not have the coin in right hand.

Close right hand, squeeze it over imaginary coin, then open it, and coin has vanished.

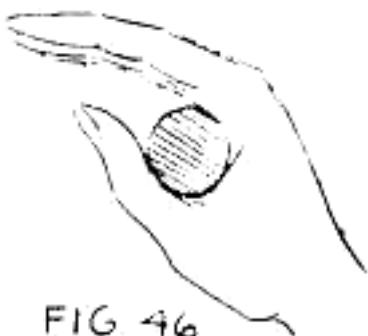


FIG 46

8 -- Invisible Thumb Vanish.

Hold coin as in Figure 26. Curve fingers inward to position shown in Figure 27 as you pretend to throw coin into left hand. From this point, however, do not continue with the Front Thumb Palm. Hold coin in position at crotch of thumb so that it can be gripped at edges as shown in Figure 46.



Now hand may be shown on both sides. When hand is shown from the back, the coin is not visible to audience. When hand is turned to show front, curve fingers inward to conceal coin. Then fingers may be straightened again to show hand from front. Figures 47 and 48.



When hand is dropped, it is easy to let coin fall into the regular Finger Palm.

(21-8)

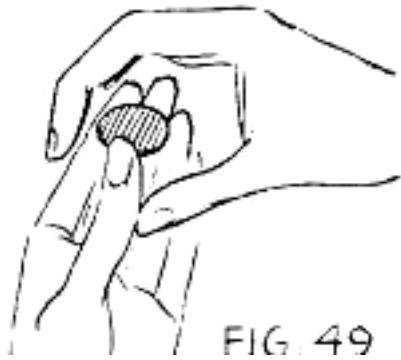


FIG 49

9 -- Le Tourniquet Vanish.

This is an old timer and is very simple. Coin is held in Thumb-Fingertip Horizontal position (Figure 18). Cover coin with right hand, allowing thumb to come under coin. Figure 49.

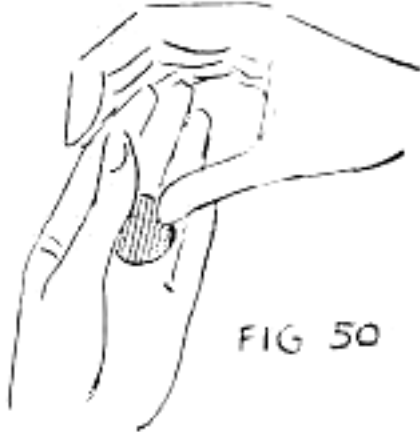


FIG 50

Now allow coin to drop into Finger Palm position in left hand. Close right hand as if you had actually lifted up coin from left hand and carried it away in right. Figure 50.

Left hand may then be dropped to side as right hand is opened to show the coin gone.

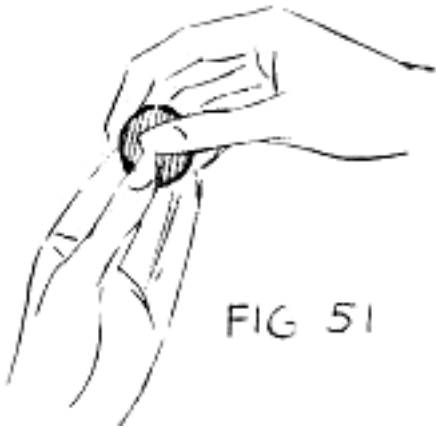


FIG 51

10 -- Pick Up Vanish.

Hold coin in left hand by the Thumb-Fingertip Vertical Hold (Figures 19 and 20). Reach down with right hand as if to pick up coin. Figure 51.



FIG 52

As right hand screens coin from audience, let the coin slip down into Finger Palm position in left hand. Figure 52.

Take right hand away as though holding coin, close it, and pretend to vanish coin. Then open hand and show it empty.

11 -- Front and Back Finger Palming.

Only one hand is used in this method of vanishing a coin and both sides of hand are shown to audience.

This method requires some skill; therefore, it will require real practice before you are ready to use it. Downs and Manuel can Front and Back Palm a quantity of coins -- even a dozen or two would be easy for them. Such work requires too much skill, however, for the average magician. I shall teach you other methods of handling a quantity of coins later on in the course. We begin here to learn how to master this principle with one coin.

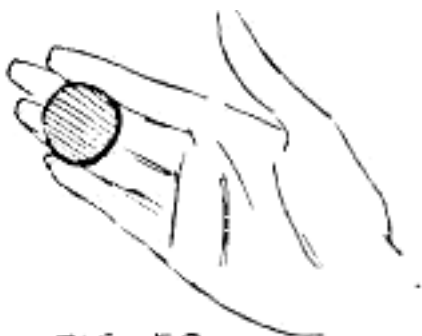


FIG 53

Hold coin in Front Finger Palm position (Figure 11). Remember coin is gripped on both sides by first and fourth fingers. Figure 53.



Curve second and third fingers under coin, holding coin securely between first and fourth fingers. Figure 54.

(21-9)

FIG 54



Let coin revolve as fingers go under it. Figure 55.

Study these moves out very slowly, but remember that, of course, they are performed very quickly and as one continuous movement.



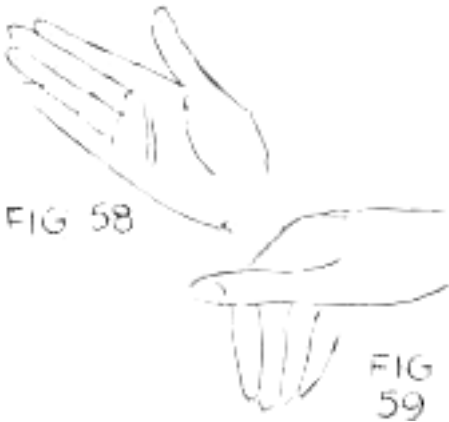
Straighten out fingers. This brings coin automatically to back of hand in same position as it was on front of hand. Palm of hand is shown to audience and it appears that the coin has vanished. Figures 56 and 57.



This first movement of getting coin from front to back of hand should be done with a big move of the whole arm. Arm is lowered slightly, then raised as though tossing coin in air. As you do this, curve fingers under coin and pivot coin to back of hand.

Now to show back of hand and yet conceal coin:

Coin is on back of hand after completing the above movements. Figures 58 to 62 show how the movements of getting the coin to front of hand again appear to the audience.



Start with hand in position shown in Figure 58, coin on back of hand.

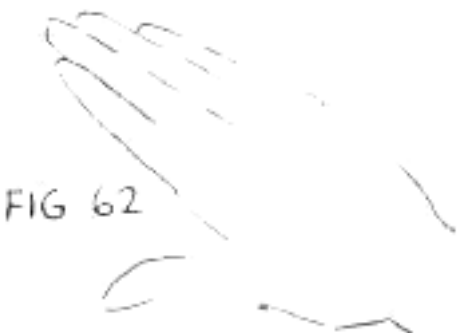
Turn fingers downward and thumb straight over them as in Figure 59.



Now bring thumb downward, turning back of hand toward audience. Figure 60.



Slide second and third fingers out from under coin, pivoting coin with them. Figure 61.



Straighten fingers out behind coin so that it is now held Front Finger Palmed again. Back of hand may now be shown to audience. Figure 62.

To show front of hand again and conceal coin:

Just reverse movements of getting coin from back to front. Start with position shown in Figure 62 and work back to Figure 58.

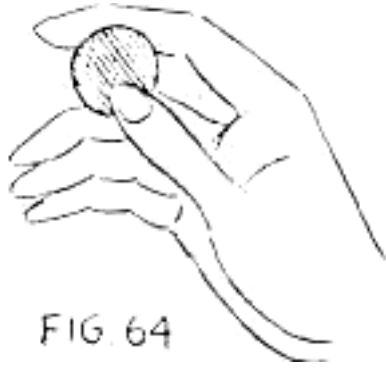


Figure 63 shows position of arm and body in doing the Front and Back Finger Palming. Right side of body is turned away from audience. Right arm is held out at side with hand elevated.

Master this principle with BOTH hands. You are then able to get effects apparently using one coin, but in reality using two, one in each hand. When one is exposed in one hand, the

(21-10)

other is concealed in the other hand. You can apparently pass a coin from the hand to the elbow, through the knees, etc. It is well, then, to have the principle at your command.



12 -- Back Finger Clip Vanish.

Hold coin as shown in Figure 64. This is also a one-hand vanish.

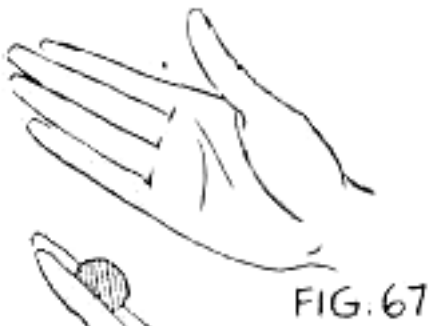


The real grip comes between tip of thumb and second joint of second finger. Lift up index finger from coin. Figure 65.



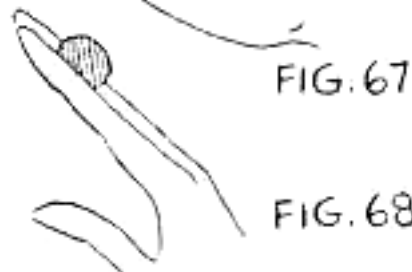
Bring index finger down on opposite side of coin. Figure 66.

Grip coin between first and second fingers and remove thumb. Coin is now held in the Back Finger Clip Position.



Palm of hand is shown to audience and coin has apparently vanished. Figures 67 and 68.

This vanish should be done with a throwing motion. Left side of body should be turned to audience and arm stretched out to the right.

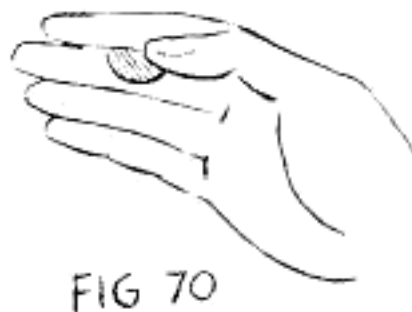


To bring coin to Front Finger Clip position:

This is a variation of Front and Back Hand Palming, but in this case the coin merely slides back and forth between first and second fingers.



Close hand so that tip of thumb can rest easily on coin. Thumb holds coin tight against second finger while first finger moves to opposite edge of coin. Thumb also aids in pulling coin forward. Figure 69.



Straighten first and second fingers, holding coin clipped between them. Remove grip of thumb. Coin is now in Front Finger Clip position. Figure 70.



During these movements the hand is turned with back toward audience. WATCH YOUR ANGLE OF VISIBILITY on these positions. Figure 71.

FIG 71



Figure 72 shows how wrist is bent slightly backward in making these movements so that audience cannot see coin being transferred from Back to Front Finger Clip.

(21-11)

FIG 72

To bring coin from front to back of hand again:

While back of hand is toward audience, place thumb against coin. Push coin between fingers to bring it to Back Finger Clip Position as you turn hand to show empty palm. Thumb screens coin until it is in back position, then it is raised and hand shown as in Figure 67.

TO GET RID OF COIN AFTER VANISHING IT IN HAND

To the audience the coin has vanished when the hand is opened, but to the performer there still remains the problem of disposing of the coin which is still in one of his hands.

The best place for depositing the coin is in one of your pockets. I described the Top Pocket Vanish before in this lesson.

Let us assume that coin is in your right hand. You want to dispose of it by dropping it into your right trouser's pocket. To do this without being detected requires MISDIRECTION.



Reach out with left hand before you open it to show that coin has vanished. As you reach forward, the body bends forward, and the right hand automatically comes near the right trouser's pocket. Have left side of body toward audience, and as your left arm swings forward to pretend to give coin to an assistant or to vanish it, slip fingers of right hand into pocket and drop coin there. Remove right hand from pocket immediately. Figure 73 shows view away from audience.

When you have perfected this move, you may even have front of body toward audience. Lean forward and make throwing motion with left hand and you will secure sufficient MISDIRECTION to enable you to drop coin in right trouser's pocket without detection. Other methods may be used, such as the following: Turn left side to audience and pick up something from table with left hand, at the same time dropping coin into right pocket.

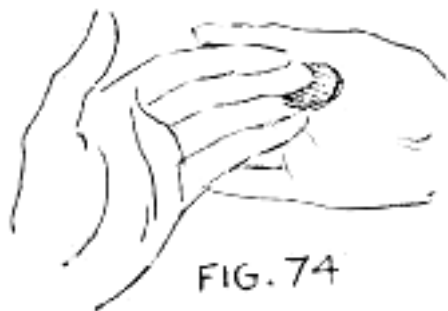
You may use the same moves for getting coin into coat pocket -- also for getting the coin from left hand into left pocket.

Many times in vanishing a coin I do not hurry to get rid of it, but take my time and drop it into my pocket when reaching for a handkerchief or some other article. Or sometimes I lay it on the table where it can't be seen when I reach for my wand.

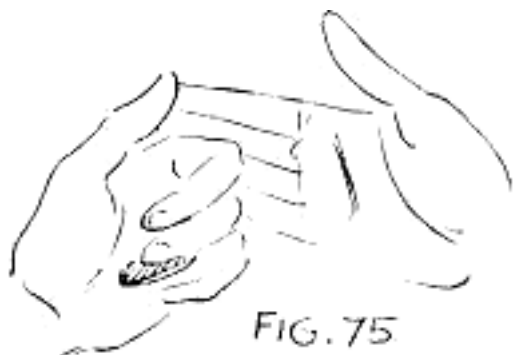
THE ELUSIVE CHANGE-OVER PALM

This is a principle which enables you to show both hands empty in a casual way without calling attention to the fact

that the coin is gone. The coin is, of course, concealed in one of your hands.

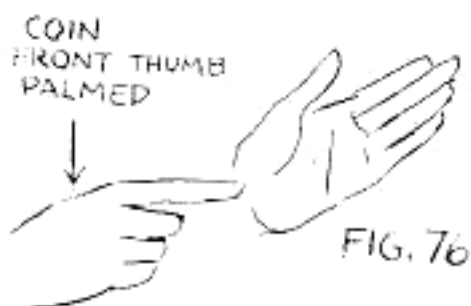


Let us assume that you have the coin Thumb Palmed in your right hand. Bring left hand up to it and grasp coin between tips of second and third fingers. Figure 74.

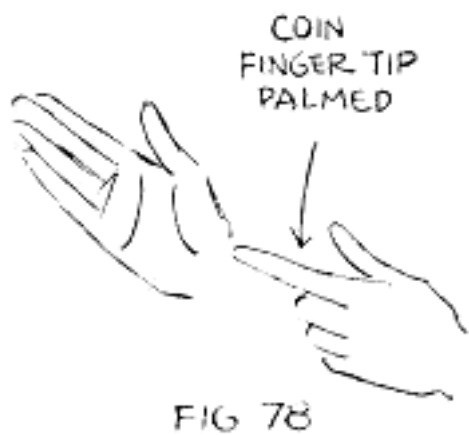


Curve fingers inward to palm of hand. This brings coin into Curled Finger Tip Palm position in left hand. Figure 75.

Right hand may now be shown freely for coin is in left hand. Reverse movement and place coin back to Thumb Palm position. This frees left hand, which may be shown to audience. That is the way the principle works.



This is the way your hands look to the audience. You have coin in right hand, Thumb Palmed, and audience sees back of right hand and palm of left. Now swing your body to the right side. As your hands pass in front, they naturally come together and you take coin in left fingers. Figures 76 and 77.



Movement to right continues. Palm of right hand, then, comes into view and back of left hand, which now has the coin Curled Finger Tip Palmed. Figure 78.

Audience has apparently seen both sides of hands. You need not say anything about your hands being empty. Merely use Suggestion.

Practice before your mirror, working out each movement carefully. Master the principle with both hands, also starting with coin Front Thumb Palmed in the left hand, then swinging to the left.

THE THUMB CHANGE-OVER

This is another Change-Over principle which is very useful.



Coin is Front Thumb Palmed in right hand. Right side of body is toward audience and hands are held up at left side, backs of both hands to audience. Figure 79.



FIG 80

Bring left hand down until front of right thumb is over back of left thumb. Change coin over from Front Thumb Palm position in right hand to Back Thumb Palm position in left hand. Figure 80.

(21-13)



FIG 81

Swing hands up together to front so that palms are toward audience. Spectators have now seen both backs and palms of your hands and think nothing is concealed. Figure 81.



FIG
82

Hold hands up at level of chest. Move them apart to show that you have nothing between them. Figure 82.

Reverse movements again to show backs of hands and get coin into Front Thumb Palm position with hands as in Figure 79.

Practice also bringing coin back into view as in Figure 21, the Production Clip. It is easy to bring coin from almost any Palm into this position. Study it until you can do it skillfully.

There is much in this lesson to keep you busy, and I hope by the time you receive Lesson 22 you will be well advanced in your mastery of Coin Sleights.

Harlan Tarbell

TARBELL SYSTEM, INCORPORATED, Chicago.

LESSON 22

Three Coin Classics are taught you in this lesson:

1 -- Fifteen coins are counted into a hat by a spectator. He removes two, and suddenly they disappear from his hand. He counts the coins in the hat again and finds that the two have mysteriously returned.

2 -- Fifteen coins are held tightly in a spectator's closed hand. Two are removed and placed in his other hand, yet they wander back.

3 -- A great trick -- amazing in its effect. A marked coin is wrapped in a piece of newspaper and given to a spectator to hold. Upon unwrapping the paper, it is discovered that newspaper has been transformed into a nest of three envelopes, the innermost containing the marked coin. Then the envelopes are changed back again to the original sheet of paper in spectator's hands.

* * * * *

Coin work permits of some wonderful effects. Here you learn three coin classics.

The first and second are based on a popular magical experiment called "Multiplication of Money". David Devant, noted English conjurer, calls it "Magical Addition", for in no part of the experiment does the money multiply. The third is also a version of an experiment popular among the older magicians, but seldom seen today. In Devant's hands, this effect was a thing of beauty. I have thoroughly analyzed the effect until I arrived at a simplified, modernized method for working it.

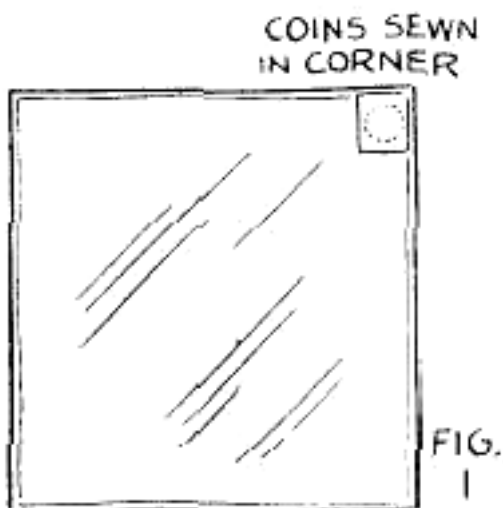
THE HOMING COINS

EFFECT:

Performer shows a plate of coins, then pours them into a borrowed hat which a boy is holding. He says that he placed fifteen coins in the hat, but the audience is a bit skeptical as the coins were not counted. Boy counts the coins and finds that there are actually fifteen. Coins are poured back into the hat again. Boy then gives performer two of the coins, which leaves thirteen in the hat. The two are wrapped in a handkerchief and given to the boy to hold. Mysteriously the coins wander back into the hat from the handkerchief. Boy counts the coins from the hat onto the plate and finds that there are fifteen as at first. Magician repeats the experiment, leaving the audience as thoroughly puzzled as ever.

PARAPHERNALIA:

- 1 -- Seventeen coins, all alike. Half dollars or palming coins are best.
- 2 -- A small china plate.
- 3 -- A small piece of magician's wax.
- 4 -- A prepared handkerchief -- with two coins, the same as those used in the experiment, sewed into the corner.



Sew square of white cloth large enough to cover coins over one corner of the handkerchief, making a pocket. Put another piece of cloth between the two coins to keep them from clinking when handkerchief is handled carelessly. Now insert coins in pocket of handkerchief and sew them in. Figure 1.

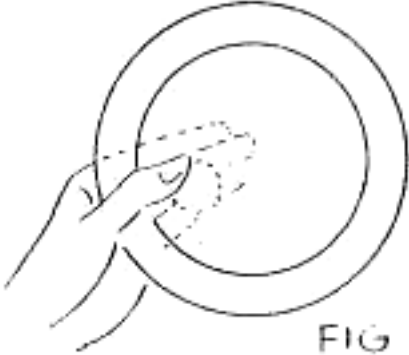
This pocket is made the same way as the one in Figure 11, Lesson 14, in which you sewed in pieces of a card.

To Prepare:

The prepared handkerchief should be in one of your right pockets.

Rub the small piece of wax well between the fingers to make it soft and stick it on your lower vest button. The piece of wax need be only about an eighth of an inch in diameter, or less.

Have fifteen palming coins on the plate.



Place two coins in left hand in position for Finger Palming. Take plate with coins in left hand, fingers under it and thumb on top. Coins can be held between fingers and plate easily, and because of natural position of hand holding plate, audience will not suspect that you have coins concealed. Figure 2.

To Perform:

Come forward with plate of coins in left hand and two coins concealed underneath.

"To begin with, I want to borrow a boy -- a boy that would be interested in money. Ah, there is a boy who looks like a good financier. I know that you will be glad to help me to mystify this audience financially. (Get boy to start forward.) By the way, we must also have a hat. Will some gentleman please give my friend his hat for a little while? There is one. Just bring it along with you."

To make it easier to get the boy to come up, you should come closer to audience. Pick out a boy and beckon to him and help to get him to the platform. As he comes forward, take his arm and lead him up to the center of the stage. Have boy stand at your left.

"Before we start with financial affairs, it might be well for us to get acquainted and exchange references. What is your name?"

Boy tells his name. We shall assume that it is John.

"John. That's a good name. My great-great grandfather's name was John. They named Johnny-Cake after him. Well, I'm glad to meet you. I have a lot of confidence in you and I suppose you have a lot of confidence in me. Of course, the audience has confidence in us for we wouldn't fool them for the world, would we, John? You see you can trust John implicitly."

To gentleman who loaned his hat:

"You do not mind if John uses your hat for a bank?" (To John) "See whether there is anything in the bank. Examine the hat carefully."

Boy examines the hat and finds it empty.

"What's the matter? Is the bank empty? Sort of short of funds, eh? John, if you will hold the hat over here for a moment I shall put some money in the bank, and we'll start a banking proposition."

Boy brings hat close to you. Turn plate so that coins fall into hat. Hold plate tilted a little above the hat so that audience can easily see the coins falling into the hat.

"Those were thirty-dollar gold pieces that I put into the hat -- thirty-dollar gold pieces made of platinum. FIFTEEN of them. Hold the hat tight, John, so that the fifteen coins will be safe."

Look at audience, then look at John, then back to audience again, and then at John again.

"John, I hesitate to say it, but there are a few people in the audience -- I shall not mention any names, of course -- who have a sneaking suspicion about the number of coins which I put into the hat. Just think of that! I put fifteen thirty-dollar gold pieces made of platinum in the hat, and they doubt my word. Of course, John knows that there are FIFTEEN coins in the hat, don't you, John? (Whisper to John to say, "No".) No? I doubt very much whether you are acquainted with thirty-dollar gold pieces made of platinum. To convince everyone that a magician tells the truth, I shall ask John to count the coins onto the plate one at a time. Count them out loud."

One by one, John counts coins out onto plate. If he does not speak distinctly, count with him so that audience can have no doubt as to the number of coins.

"FIFTEEN -- no more, no less. All right, we'll place them back in the bank."

Pour coins back into hat again. Be sure to hold plate so that audience can see coins dropping into hat. As coins slide down, release the two concealed in your fingers and let them slide down with the rest into the hat. To do this bring edge of plate near top of hat. Figure 3.

There are now SEVENTEEN coins in the hat instead of fifteen. Audience, of course, thinks there are fifteen.

Place plate on table.

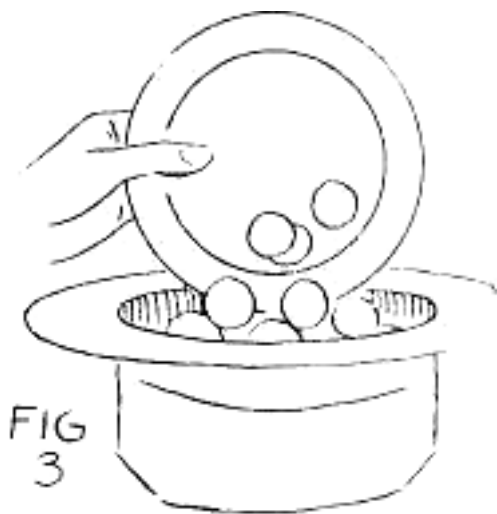
"John, take TWO coins out of the hat and give them to me."

Take the two coins which John gives you and show them to audience to convince them that there are two coins.

"One -- two."

Whisper to John to turn hat around in a circle.

"What's this? Passing the hat around? You must be a deacon. Hold the hat up high -- as high as you can reach comfortably."



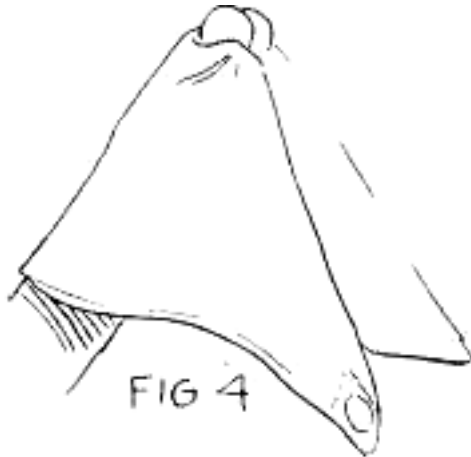
When the hat is held high, John is prevented from looking inside and counting the coins.

Show the two coins you have, one in each hand, flat sides of coins to audience.

To John:

"Two from FIFTEEN is thirteen, isn't it? You aren't superstitious about holding THIRTEEN coins, are you?" (To audience) "John says that thirteen are better than ten. He has an eye for business."

Place both coins in left hand. Reach into pocket and bring out the prepared handkerchief. Place it over your left arm, then take coins with right hand. Place handkerchief over left hand with the ends falling down. Have faked end near you and away from audience.



Show both coins slightly apart and place them in center of handkerchief in left hand. Grasp coins through the handkerchief with tips of fingers and thumb of left hand. Figure 4.



Now as you bring right hand up towards coins, catch the faked corner of handkerchief between third and fourth fingers. Grasp coins between first and second finger tips of right hand. Figure 5.

With left hand throw handkerchief over coins and your right hand and pretend to pick up coins in left hand through the handkerchief. In reality you grasp the coins in the faked corner and FINGER PALM the free coins in the right hand. Draw right hand downward and away as left hand lifts handkerchief up.

"I shall wrap the two coins in this handkerchief and ask you. John, to hold them securely. Hold the hat in your right hand and the handkerchief and coins in your left."

Give handkerchief to John so that he grasps the coins. He feels them and believes he is holding the two coins you just put under it. The ends of the handkerchief hang down.

Be careful of your ANGLE OF VISIBILITY with the coins Finger Palmed in your right hand. Neither John nor the audience must see them.

"You feel the two coins all right through the silk of the handkerchief, do you? Good! Hold them tight. Imagine you are Scotch. The money which I took from the bank reminds me of homing pigeons -- take them away but they fly back again. John, what would you say if the two coins you are holding should fly out of your hand into the hat? Say, 'Go.'"

As John says, "Go", take hold of a corner of handkerchief with left hand. Whisk it from his hands suddenly, and to all appearances the coins have mysteriously vanished.

"I guess they went."

Take handkerchief in right hand, and as you pick up plate from table with left hand, place handkerchief in right pocket. Now transfer plate to right hand, thumb on top and fingers concealing two coins under it.

You now have the same arrangement that you had in your left hand when you began this experiment.

"Count the coins! in the hat, John, to see whether the two coins flew back to the bank again. If so, there should be FIFTEEN again, instead of THIRTEEN. Count them one at a time out loud".

John counts coins onto plate.

"Fifteen. They did come back. By the way, John, would you like to have me teach you this trick so that you can do it? You would. Then you shall have a lesson. The most important part is to be able to get as many as FIFTEEN coins together all at once. Place them on a plate, or platter, if you like. Get someone's hat and pour them into it, all FIFTEEN. Sometimes the audience doubts you, that is why I had you count them one at a time out loud."

As you say, "Pour them into it", pour the coins back into the hat as you did before and let the two coins in your right hand slide into the hat with the others.

"Usually someone holds the hat but as no one is handy, we'll just set it down over here on the table. But before we do that, take out TWO coins."

John takes out two coins.

"Place the hat on the table."

Boy places hat on table.

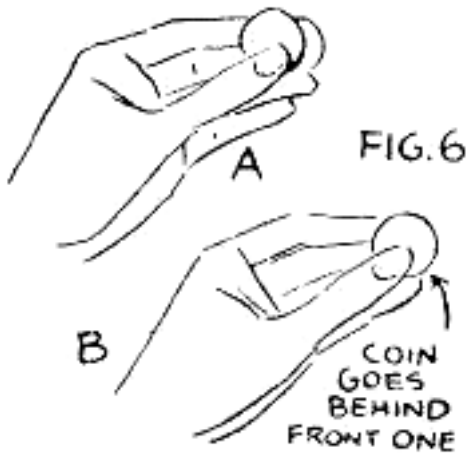
"And give me the two coins."

Take coins in left hand and as you do so, pick ball of wax from lowest vest button with tips of first finger and thumb of right hand. Bring coins over to right hand and press the wax on center of coin towards you. Press it out flat with right thumb to spread it on coin. You can do this easily without being detected.

"Of course, that leaves THIRTEEN in the hat. Now watch what I do with the coins."

Have waxed side of coin toward you. Have second coin in front of first, toward audience, but keep them a little apart. Hold coins in left hand.

Show both coins plainly so that all can see the two of them. Move waxed coin away a few inches with right hand and replace again on other side of second coin so that wax is between the two.



"Are you watching both coins, John?"

FIG.6

Turn left hand to audience as in Figure 6A. Screen coins with right hand, apparently taking coin from behind, but in reality push two coins together and press tightly with fingers and thumb of left hand. Figure 6B.

Remove right hand fingers as though taking the coin. Open them slowly and show that coin has vanished.

"There is one gone."

Throw double coin over to right hand and then back to left. The coins will hold together as one, and no one will notice the extra thickness. When holding coin up to audience, flat side should be exposed.

Hold double coin in Finger Tip Clip position (Lesson 21, Figure 16). Pretend to throw it into left hand, which closes as though holding coin. During throwing motion, Front Thumb Palm double coin in right hand. Point index finger toward closed left hand and make motion toward it. While doing this, raise hand to upper left coat pocket and let coin drop into it. (See Lesson 21.) Open left hand and show that coin has vanished. Now show both hands, fingers spread wide apart.

"And the second one has likewise melted away. But, as you know, John, they really flew back into the hat -- that is, if you have done the trick properly. Pick up the hat and count the coins one at a time again onto the plate."

Boy picks up hat and you pick up plate. He counts the coins aloud.

"FIFTEEN. There, John, you have performed the trick well, and if anyone wants to hire you to bring their money back again, I'll give you a good recommendation."

Dismiss boy and return hat, or you may retain him or the hat for another experiment.

* * * * *

INVISIBLE MONEY TRANSIT

Another version of the "Multiplication of Money" experiment.

EFFECT:

Performer brings forward small plate on which are fifteen coins. These he pours into a spectator's hand, who counts them one at a time onto the plate to prove that there are fifteen coins. Performer is given two of the coins, and then the rest are again returned to spectator's hand. Thus thirteen are left in the hand. Magician wraps the two coins in a handkerchief and gives them to spectator to hold also in other hand. Upon command the two coins disappear from the handkerchief and appear mysteriously with the thirteen

coins. Spectator counts coins one at a time and finds that he holds fifteen in his hand.

PARAPHERNALIA:

- 1 -- Seventeen coins, preferably palming coins or half dollars.
- 2 -- A small plate or saucer.
- 3 -- Special handkerchief with two coins sewed into corner, as described in preceding experiment.
- 4 -- Small piece of wax, as in above effect.

SECRET AND PATTERN:

To Prepare:

Place small piece of wax, less than an eighth of an inch in diameter, on bottom button of vest. Put special handkerchief in a handy pocket.

Have fifteen coins on plate and two under it, held in hand, as in preceding experiment.

To Perform:

Come forward with plate and coins arranged as described, holding them in left hand.

Have spectator come up from audience and stand at your left.

"I have had people say that they liked the experiment I am about to perform because there is money in it. I suppose, sir, that you too are interested in money. Now, I have a whole plate of it. These are thirty-dollar gold pieces -- I do not know what they are made of, perhaps white gold or tin."

Pick up one coin and show it to audience. Replace it on plate.

"There are fifteen of these coins."

Pour coins from plate into your right hand, keeping coins under plate in position.

"I will ask you to take them."

Give coins to spectator helping you.

"And count them one at a time out loud on this plate as I hear a peculiar vibration passing through some of the members before us signifying their doubt as to whether there are fifteen coins."

Spectator counts coins one at a time aloud and places them on plate. If he does not count loud enough, count with him. Be sure that everyone is satisfied that there are fifteen coins.



"Fifteen. You are to be congratulated on your counting."

Grasp plate with right hand and pour coins into left hand. Hold back of plate toward audience in this case. Pour the fifteen coins into the left hand with the two coins already there. Figure 7.

Now give coins to assistant.

NOTE: If you desire, you may pour the coins from the plate into your right hand, also releasing the two coins from under the plate and allowing them to drop with the rest. Or if you prefer, coins may be poured directly into assistant's hand, holding plate in left hand.

"Please hold the FIFTEEN coins again -- in your left hand."

When spectator has coins in hand, say,

"Close your hand tightly so that none of the money will evaporate. They say that money is hard to hold onto. That's why I want you to hold the coins tight."

The real reason is that you do not want him to see the coins and count them.

"By the way, before we go any further, I want to borrow TWO of the coins. Will you give me just two of them?"

Take the two coins from spectator.

"Now close your hand tight again. Pretend you are a Scotchman whose wife has asked him to buy her a new hat."

Take small piece of wax from vest button with right hand and press it onto the center of one of the coins. Keep waxed side toward you and away from audience.

Hold coins in full view in left hand. Slip front coin back of the other so that wax comes between them. Do not press together as yet.

Reach into pocket and remove special handkerchief with right hand. Throw it over left arm. Transfer two coins to right hand, then cover left hand with handkerchief and place coins at left finger tips. Grasp them thorough the handkerchief. Be sure to have faked corner of handkerchief away from audience.

Wrap up the two coins as you did in preceding effect, raising the faked corner to center and wrapping coins therein. Grasp fake corner through the handkerchief in left hand and with right press the two free coins together.

FRONT THUMB PALM the double coin in right hand and remove from under handkerchief.

"Will you please grasp the two coins with your thumb and finger tips of your right hand? Now keep your hands apart."



Give handkerchief to spectator so that he grasps the faked corner in the center of it. He holds this in right hand and the rest of the coins, supposedly 13, in his left hand. Fig. 8 shows position of assistant.

Now raise your right hand to upper left coat pocket and drop double coin in it. It will not click if pocket is empty for wax holds the two coins tight together. It is well, as suggested before, to have a little stiffening in upper part of pocket to keep it open. Sometimes a fountain pen in one corner of the pocket answers the purpose.

"Do you feel them? Just hold these two coins in Scotchman fashion. Imagine you are a banker and someone wants to borrow some money. It takes a magician to get money from some people nowadays. Anyway what I intend to do is to cause the two coins over here to jump back with the other coins over there. You would, no doubt, be surprised to see them jump. Of course, they may jump without your seeing them. They say it is hard to see money sometimes, especially when it is scarce. There is a lot turned out of the mint that you and I never see."

Take hold of one corner of the handkerchief.

"Are you ready to see the money go? Money goes fast -- usually faster than it comes, so watch closely. You still feel the coins, sir? All ready -- Go!"

Whisk handkerchief suddenly out of spectator's hands. The coins in it have apparently vanished.

"They've gone."

Place handkerchief in pocket or on table as you pick up saucer.

"No doubt, you feel the weight in your left hand heavier by two coins. Please count the coins out on the plate again, and you will find that instead of thirteen coins you have FIFTEEN for the two coins have passed over into your left hand."

Assistant counts coins one at a time aloud until the fifteen have been counted.

"FIFTEEN."

NOTE: In case you are performing and have no wax handy, vanish one of the coins in your upper left coat pocket, then drop the other coin in another pocket when convenient.

Or you may use this ruse for vanishing both coins. Take out your watch for the purpose of taking the assistant's pulse. As you do so, drop both coins into your pocket.

Hold assistant's wrist for a few seconds, then say, "Yes, your heart is all right." Replace watch in pocket and proceed with experiment. Sometimes I allow two coins to remain Finger Palmed until I jerk handkerchief from spectator's hand. Then I place coins and handkerchief in pocket.

* * * * *

THE COIN IN THE MAGICAL ENVELOPES

This experiment is really a Coin Classic. When skillfully done, its effect is wonderful.

EFFECT:

Performer requests that a spectator mark a half dollar and loan it to him. He wraps this coin in a piece of newspaper and gives it to spectator who is assisting him to hold. He then waves a piece of sealing wax over the parcel. Spectator opens newspaper and finds that it has been converted into a large newspaper envelope sealed with wax. Upon opening the envelope, he finds that another sealed envelope is enclosed in the first. The second envelope is opened and it contains a third sealed envelope. The third is opened and is found to contain the half dollar.

Magician then offers to show assistant how to do the trick. He repeats it and this time the envelopes are opened and the loaner of the coin finds his marked coin in the third envelope.

Performer then suggests that assistant might like to keep the six envelopes as a souvenir. He gives the assistant the envelope crushed into a ball. A mishap occurs however. Magician accidentally touches the assistant's hand with the sealing wax and this causes the envelopes to change back again into the two pieces of newspaper which they were originally.

PARAPHERNALIA:

1 -- Three copies of the same newspaper.

Select a sheet and remove it from each of the three newspapers. Use single sheets (double sheets cut in half).

2 -- Two half dollars with the same date. Put small cross marks exactly alike on each.

3 -- A borrowed half dollar. Borrow one which matches the others as nearly as possible.

4 -- Stick of sealing wax.

SECRET AND PATTERN:

To Prepare:

Take one of the three selected sheets of newspaper and cut it in two, from top to bottom and not across. Figure 9.

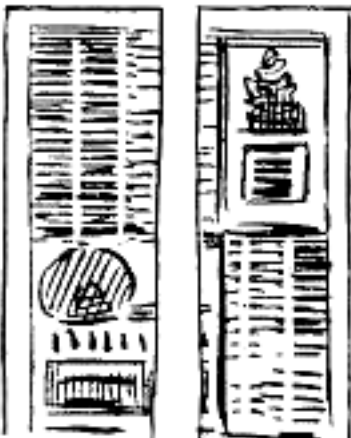


FIG. 9

Take one of these half sheets. Cut from it three squares of paper in the following sizes:

1 -- 8 1/2 x 8 1/2 inches

2 -- 7 1/2 x 7 1/2 inches

3 -- 5 1/2 x 5 1/2 inches

From each of these squares you are to make an envelope.

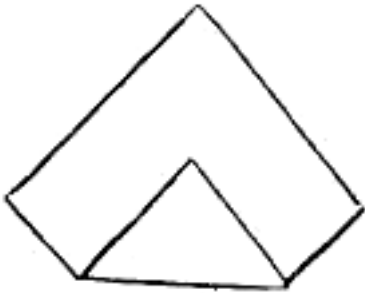
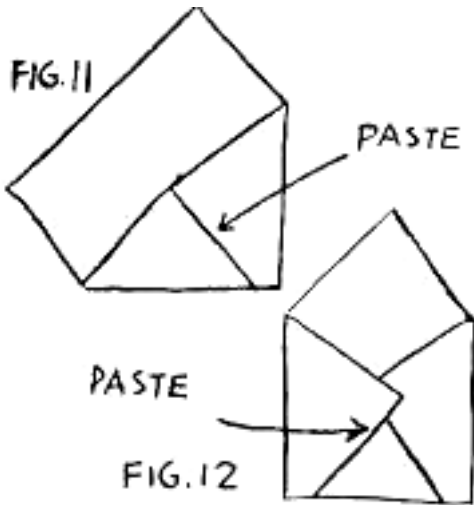


FIG. 10

Take the largest square. Fold over one corner about three inches. Figure 10.



Now fold over the corner on the right side. Figure 11. And finally fold the corner on left side. Paste these corners down to make an envelope. The open corner forms the flap. Figure 12.

Make envelopes of the other two squares also.

Fold down the flaps. Through the crease in the top of each cut a slit about an inch and three-quarters long with a sharp knife.

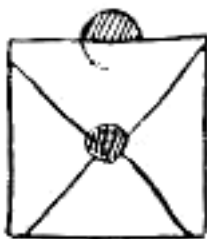


FIG. 13

Take one of the half dollars and insert it halfway into the smallest envelope through the slit. Fold down the flap and seal it with some sealing wax. Figure 13.

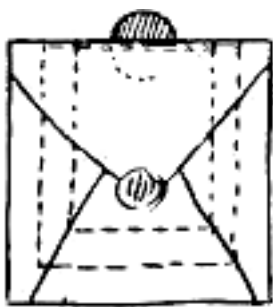


FIG. 14

Place this envelope in the next largest one with the coin protruding from the slit. Fold over flap and seal with wax. Then insert these two sealed envelopes in the largest one with the coin protruding from the slit. Seal down the flap with sealing wax. You now have a package of three envelopes with a half dollar sticking out halfway through the slits. Figure 14.

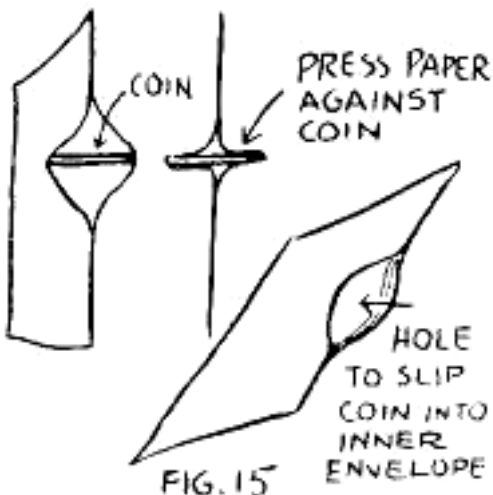


FIG. 15

Be sure that all three slits are even. Now turn half dollar at right angle to slits and press paper against it. Remove the coin and a hole from the outside into the inner envelope remains. Figure 15.

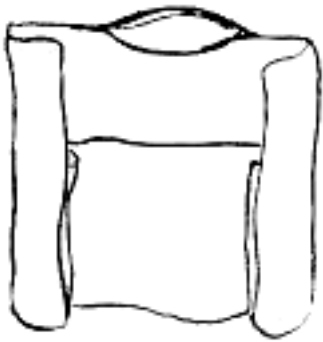


FIG. 16

Fold the bottom up a little and the sides over just enough to keep the three envelopes in position. Figure 16.

Place package of envelopes in right trouser's pocket with hole in envelopes up. You will find that you can easily slip a half dollar into this hole and thus into the inner envelope of the three.



FIG. 17

Take the other half sheet of paper and cut it into three squares as you did with the first. Make three envelopes. In the smallest one place the other half dollar. Seal envelope with sealing wax, enclose it in the next largest one. Then place these two in the largest one and seal it. Figure 17 shows how the three envelopes look when you have the whole package made.

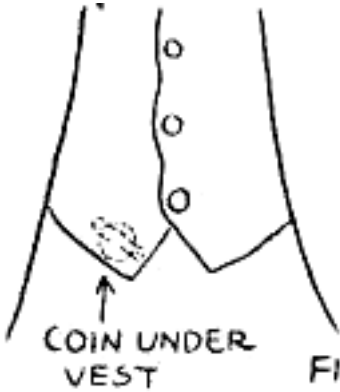
Crush this package into a ball.

Take another of the selected sheets and cut it in two as you did with the first. Take the half which matches the envelopes that you just screwed up into a ball. Place this on table with the ball just under it and concealed from audience. Place the other half sheet nearby.

If working with a suitcase, as is common with club work, just have ball of envelopes and paper in case.

Now take the third sheet of paper and cut it in half. Roll the two halves into a compact ball. Place it in right coat pocket.

Have a half dollar handy so that you can get at it easily for Finger Palming.



I suggest that you sew a half-inch piece of elastic under vest at lower right side. Insert half dollar in this, and when the time comes you can easily slip right fingers under edge of vest to Finger Palm it. Figure 18.

Or if you prefer, place the coin in a convenient pocket which you can reach easily when time comes to Finger Palm the coin in right hand.

FIG. 18

Place stick of sealing wax in left coat pocket.

To Perform:

Have a spectator come up to help you. Ask him to be seated a moment and take charge of the stage while you go down into the audience and borrow a half dollar. Take coin from some gentleman in the audience, then return it and ask that he mark it so that he can easily identify it.

"Mark it well so that you can readily identify it in case you see it again -- or rather in case you do not see it again."

While he is marking it, get coin from under vest or from pocket and Finger Palm it. Have second, third, and fourth fingers curled around coin so that it cannot be seen by audience. You may grasp your coat lapel with right hand also to dispel any suspicion that you have something in right hand. Take marked coin between thumb and first two fingers of right hand, keeping back of hand uppermost.

Pretend to transfer coin to left hand, but as you toss coin, FRONT THUMB PALM the marked coin in right hand and let your own coin fall into left hand. Just before doing this bring the marked coin to Finger Tip Clip position so that movement will be easy. When you have disposed of your coin into left hand, let marked coin fall into regular Finger Palm position.

Go back to stage. Have assistant stand at your right as you face audience. Give him your coin from your left hand. The audience thinks, of course, that you have given him the borrowed marked coin. Tell assistant to close his hand over

coin. Now you stand away from him for a moment, your left side toward audience.

"Now, Sir, if in three minute's time you were to open your hand and find the half dollar had vanished, you would be surprised, wouldn't you?"

Assistant says, "Yes," or laughs.

"And so should I."

As you talk to assistant, slip right hand into right trouser's pocket and let marked half dollar fall through the slit in the envelopes into the smallest one. When you do this, insert your first and second fingers into the slit to make it easy for coin to slide in. Close hole and roll envelopes into a ball. You will have no difficulty in doing this without being detected for audience is laughing at your last remark and there is a slight pause in your performing.

Remove hand from pocket.

THE IMPORTANT PART OF THE TRICK IS NOW DONE. The trick is really over before the audience thinks it has begun.

"Well, I am not going to do this trick that way. Money disappears easily enough without adding magical influence to it."

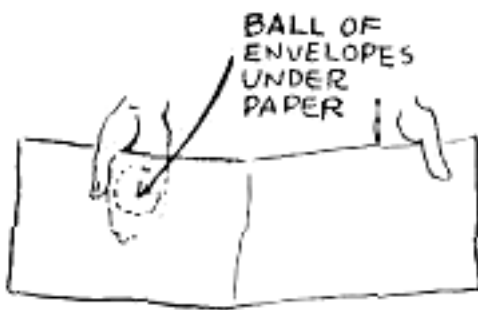


FIG 19

Go to table and pick up newspaper with ball of envelopes behind it. Hold it with right hand, thumb in front toward audience and rest of hand behind holding ball. Grasp other end of paper with left hand and fold it over in half. Open paper up, then close it again. Figure 19.

"I am going to ask you to place the half dollar on this piece of paper under my thumb."

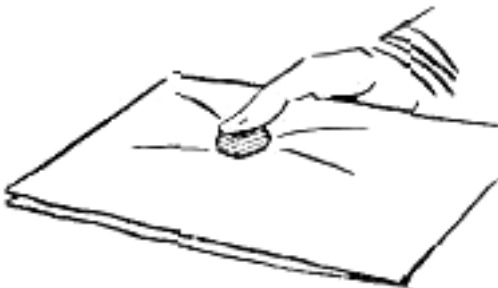


FIG. 20

Hold right hand toward assistant with paper folded over double and ball concealed under it. Have him place coin under your thumb. Figure 20.

Roll paper into a small ball with coin inside. Be careful to keep ball of envelopes concealed behind it. Hold the two balls together and hold them up as one for the audience to see.

"Strange thing about paper -- the smaller you roll it the smaller it becomes. Just take the half dollar wrapped up in the paper and hold it this way."

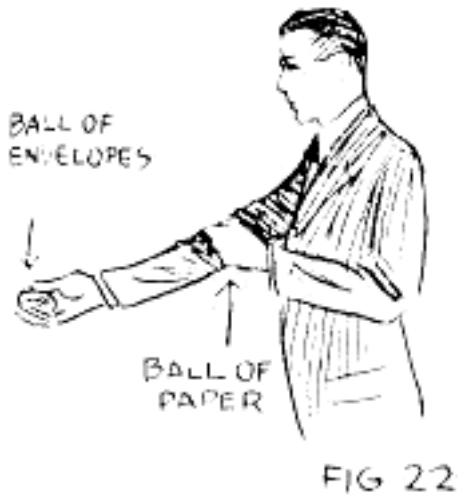


FIG. 21

As you talk, turn the two balls of paper around so that ball of envelopes is on top. Press into left hand with cupped right hand. Figure 21.

Curl second, third, and fourth fingers of left hand around ball of paper underneath and palm it.

Lift ball of envelopes away with right hand and hold up so that audience can see it.



Now turn to give this ball to assistant. Extend right hand to him and let left hand come up to grasp right sleeve at elbow. This is a natural movement and helps you to conceal palmed ball in left hand. Figure 22.

Hand ball to assistant.

"Hold it tight while I get some sealing wax."

Reach into left coat pocket with left hand and drop palmed ball therein as you bring out stick of sealing wax.

"Take the sealing wax and touch the back of your hand three times, then open your hand. What has happened? Nothing? Strange! Suppose you open the parcel and show it to the audience. After all, you know we must let them see part of the trick."

Take wax from assistant and replace in left coat pocket. Assistant unfolds paper and finds a large envelope instead of the half sheet of newspaper which he expects.

"The mystery deepens. What have we? An envelope, securely sealed with wax. I think the wax is still warm. Please open the envelope."

Assistant opens the envelope and takes out the second envelope.

"Another sealed envelope! Take it out. By the way, this is the very latest fashion in envelopes -- made of newspaper. Up on the second envelope."

Assistant opens it and takes out the third envelope.

"Well, a third one. Open it, please, and you will perhaps find the half dollar."

Assistant opens third envelope and takes out half dollar.

"To show you that this is the same paper we started with, just examine the half dollar. You see it is the same."

Half dollar has marks on it and appears to be the same as the borrowed coin.

At this stage audience thinks the trick is done and will, no doubt, applaud you. Anyway, while assistant is identifying coin and audience is in that frame of mind, you can secretly prepare for the next stage of the trick.

Reach into right trouser's pocket and squeeze the envelopes into a ball. Remove the ball Finger Palmed in your right hand. Grasp your right coat lapel with right hand to conceal ball.

"Will you please take the coin down to the gentleman from whom we borrowed it? Or just a minute -- before you return the coin. Will you remember what I did so that you

can do it when you get home? First I borrowed a half dollar, had it marked so that the owner would know it when he saw it again and then had it wrapped in a piece of newspaper."

Reach over with left hand and pick up newspaper. Turn your right side toward audience. Transfer paper to right hand so that it is held as in the beginning of the experiment with the ball behind it. Now turn to right so that your left side is a little toward audience.

IN PERFORMING THIS REPEATED VERSION QUICKEN YOUR MOVEMENTS. You are repeating and pretending to explain. As you know, it is not wise to repeat an experiment in Magic. In this case, however, it is all right for you leave the audience just as puzzled as they were after the first showing. Do it with plenty of snap nevertheless.

Request that assistant place coin on paper again.

"Place coin on paper again. That's it. Now you remember I rolled the paper into a ball and gave it to you."

Roll up paper into ball, exchange it for ball of envelopes in right hand, and give envelope ball to assistant. Palm other ball in left hand as illustrated in Figure 21.

"And then I told you to touch it with a piece of sealing wax."

Reach into left coat pocket for wax and leave ball of paper there. Give wax to assistant.

"Touch it three times."

Take back the wax.

"Now, all you have to do is to open the parcel and there are our envelopes. Open the first. Now the second. Now take the third one down to the owner of the coin and let him open the envelope and remove his half dollar."

Assistant takes envelope down to loaner of coin.

"Just as soon as the owner has removed his coin, will you please bring the envelope right back to me again?"

This prevents assistant from examining the coin too closely. While assistant is returning to stage, say to owner of coin,

"That is your coin, is it not? It is. Thank you."

YOU MUST IMPRESS ON YOUR AUDIENCE THE FACT THAT THE COIN IS THE ONE WHICH YOU BORROWED, otherwise much of the effect is lost.

While all this is going on, it is easy for you to reach into your left coat pocket and Palm out the ball of paper from it. Grasp lapel of your coat again.

Now gather up envelopes from table and place ball of paper behind them. Say to assistant,

"Perhaps you would like to have all these envelopes as a souvenir of this little occasion. With the envelopes in your possession, you are sure to know how to do the experiment."

Take envelope from assistant and place with the rest. Show them freely, then roll them all up into a ball. Press Palmed ball against it and show both as one.

"Yours with pleasure."

Go through the routine as before, Palming ball of envelopes in left hand and handing ball of paper to assistant.

"And I suppose you want the magic sealing wax also."

Reach into pocket for sealing wax and leave ball of envelopes there.

"However, there is just a little warning I want to give you. Be careful when you are holding the envelopes in your hand not to touch your hand with the sealing wax."

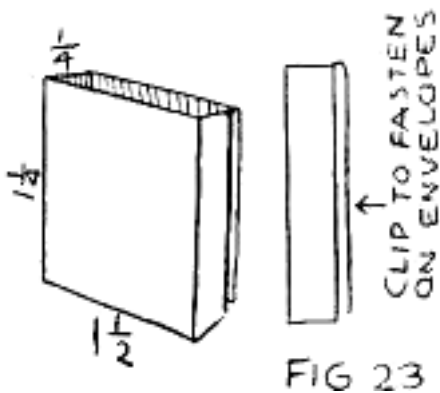
As you say this, touch his hand with the wax.

"Or you will find that the envelopes will turn right back to plain paper again. I believe, after all, that I had better keep the sealing wax. (Place it in pocket again.) Just open the paper now."

Assistant opens ball and finds the two half sheets of newspaper instead of the envelopes. Help him to spread them out.

"Well, anyway you know how it is done -- and perhaps some day you will be good enough to tell me so that I can do it myself."

NOTE: You should have no difficulty in getting coin into nest of envelopes in pocket. If you desire, however, you may make a little tube of cardboard or tin. This must be large enough to allow a half dollar to slide through easily and must have a big enough opening to find easily.



Have tube made 1 1/2 inches wide by 1 1/4 inches high by 1/4 inch deep. It is open, of course, at top and bottom. Have a piece at back by which to clip tube to envelopes. Figure 23.

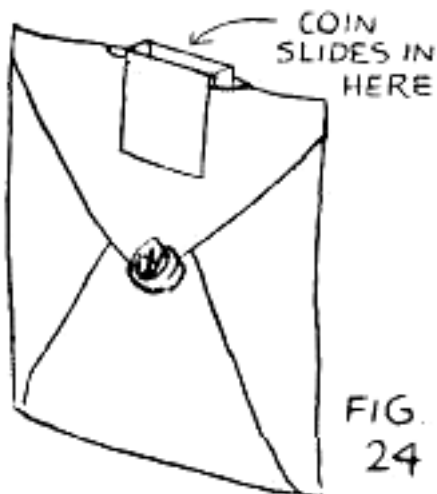


Figure 24 shows how tube fits into slits in the three envelopes. This allows an open passage for the coin into the smallest envelope. After coin has been dropped in, remove the tube and leave it in pocket.

LESSON 23

A fascinating lesson with coins in which you learn to make the half dollars appear and disappear most mysteriously. You learn to pick them from here and there out of the air, from your elbow, from your knees, from a spectator's ear, from every imaginable place. And for presentation you learn these interesting effects:

1 -- The Miser's Dream. A quantity of coins are caught in rapid succession from the air with the empty hand, and are then tossed into a hat. More coins are then produced from your knees, from a lady's hair, etc.

2 -- A knot is tied in a borrowed handkerchief. A marked coin is then borrowed from a spectator and placed in an envelope. In a puzzling manner the coin travels from the envelope into the knot in the handkerchief.

3 -- Two clever methods for vanishing a coin which is wrapped in paper.

4 -- Two empty glass tumblers are shown. Into one are counted five half dollars. This is then held in left hand. Other glass is held in right hand some distance away. Upon command the coins pass one at a time from the left glass to the empty right one.

* * * * *

A handwritten signature in cursive script that reads "Harlan Tarbell". The signature is fluid and elegant, with a prominent flourish over the "l" in "Tarbell".

TARBELL SYSTEM, INCORPORATED, Chicago.

(22-16)

LESSON 23

This course in Magic would not be complete unless you were taught the famous Miser's Dream effect. It was a very popular number with T. Nelson Downs in his Coin Act. The experiment is very interesting for it permits of many variations. The money can be picked out of the air, from various parts of the performer's body, from the whiskers of some spectator, from a lady's coat, or it may be caused to fall in a shower when someone sneezes.

The other effects in the lesson also offer good opportunity for manipulative sleights with coins in vanishing and producing them. I teach you the general principles and I want you to work them out to fit various occasions. In tricks where there is repetition, you must vary the means of producing coins so that you do not lose the punch of the experiment. You must add spice to the effect and keep your audience interested.

This lesson is based around the use of two dozen half dollar-size Palming Coins. If you desire, however, you may use more coins, even as many as fifty.

THE MISER'S DREAM

EFFECT:

Performer borrows a derby hat from a spectator and shows it empty. Then he reaches into the air and produces a half dollar, which he tosses into the hat. From then on, in an amazing manner he produces coins from here, there, and everywhere. The supply seems to be endless and the audience is bewildered by the mysterious happenings.

PARAPHERNALIA:

1 -- Two dozen Palming Coins.

(It is well to have a supply of these coins on hand for your various coin effects.)

2 -- Three black safety pins from 1 7-8 to 2 inches long.

3 -- A borrowed derby hat. A derby is preferred because it is stiff and the coins make a noise when they are dropped into it. In case of necessity, use a soft felt hat, although the experiment is not so effective when it is used. Sometimes a performer carries his own derby hat for the experiment.

SECRET AND PATTERN:

To Prepare:

Place nine coins in your empty left trouser's pocket.



Inside the right side of your coat about an inch and three-quarters from the bottom, place one of the black safety pins. About one-half inch back of it, place the second pin, and one-half inch back of that, the third one. Figure 1.

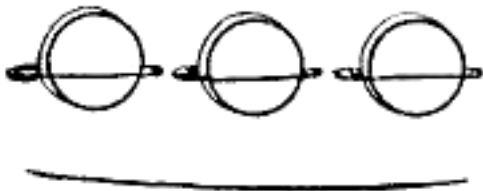
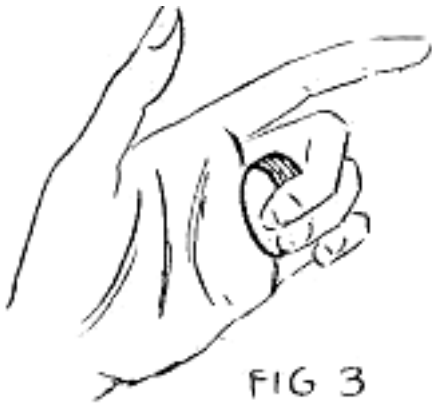


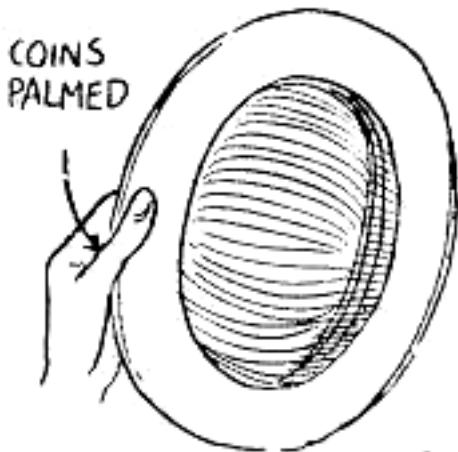
FIG 2

Close each pin and into each place five coins. The wire on each side has enough spring to hold the coins securely. You may have to pull the wires apart or push them together a little to adjust them to the coins, but this is an easy matter. Allow a larger section of the coins to extend above the pins and a smaller section below the pins. This is done to make it easier to release the coins when you need them. Figure 2.



To Perform:

Borrow a derby hat. Hold it in right hand, and as you go back to stage, reach into left trouser's pocket with left hand. Stack the nine coins and bring them out Finger Palmed—the coins rest at base of fingers and are held in place by tips of second and third fingers. Remove hand from pocket. Be sure that fingers conceal coins. Figure 3.



As you turn to face audience (right turn), transfer hat from right to left hand. Grasp hat with thumb and index finger of left hand. Figure 4.



FIG 5

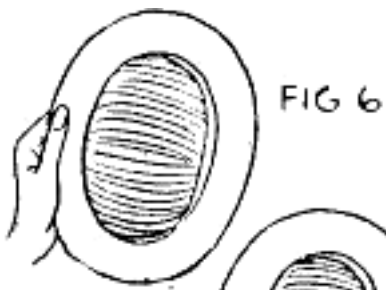
This position gives you a good grip on hat and completely conceals coins so that hat may be shown from all sides. Figure 5.

"Deep down in our hearts there seems to be the desire to make money fast. Almost anyone would rather like to wake up in the morning and find himself a millionaire. I have learned, however, that the only safe way to make money fast is the magical way. You see there is plenty of money around, but the trick is to get it. Are you aware of the fact that the air is full of money and that it lurks in the most unexpected places? Now all that a magician needs to make money is his empty right hand."

With hand pointing downward, show right hand on both sides, fingers wide apart.

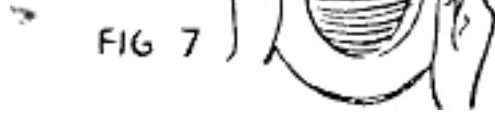
"And he uses a hat to hold the money in."

Show hat empty, even examining it under the hat band.



Hold hat up in left hand with opening toward you. Grasp other edge of brim with right hand. Figures 6 and 7.

(23-2)



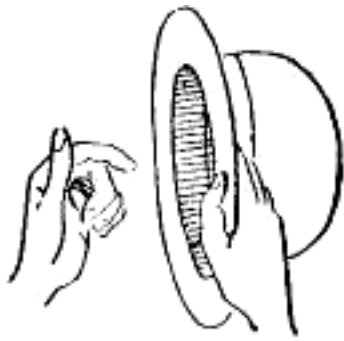


FIG. 8

Remove left hand from hat and bring it over to right hand. Turn hat with right hand. Figure 8.



FIG 9

Grasp hat just above right hand with fingers of left hand inside the hat and thumb outside. Remove right hand from brim of hat. Figures 9 and 10.



FIG 10

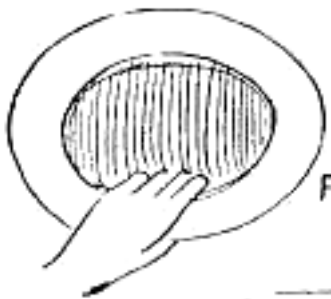


FIG 11

As you bring left hand into position, let the coins arrange themselves along the inside band of the hat and hold them in place with your finger tips. Figure 11 shows how coins are concealed by fingers of left hand inside the crown of the hat. Nothing is visible to the audience. Figure 12 shows how coins are arranged along the band of the hat under the fingers.



FIG 12



FIG 13

Figure 13 shows a detailed view of the arrangement of the coins. They are spread a little apart and overlap each other. The one on top is nearest the finger tips.



FIG 14

Push top coin forward a little with fingers so that it is ready to be released. It is now easy for you to allow this coin to fall into the hat at the desired moment. Figure 14.



FIG 15

With right side of body toward audience, reach into air with empty right hand and pretend to pick a coin from nowhere. Close hand as though it holds a coin, then open it slowly and show empty hand as though coin had gone again. Reach up again and take an imaginary coin from the air. Figure 15.



FIG 16

Toss this imaginary coin into the hat. As right hand is over the hat, release the top coin under your left fingers and let it drop into the hat. The illusion is perfect. The audience hears the coin fall and it appears that you actually threw a coin into the hat with your right hand. Figure 16.

(23-3)



"There's one coin."

Reach into hat and take out coin. Hold in Finger Clip position and show it to audience on both sides. Figure 17.



Now apparently toss coin back into hat again, but as right hand travels toward hat, Front Thumb Palm the coin. Figures 18 and 19.



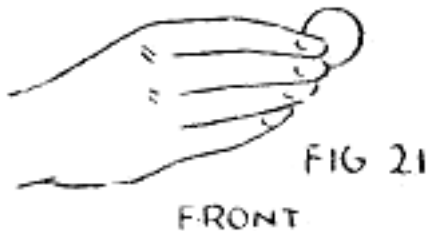
Continue movement of right hand to hat as though throwing coin in. Figure 16.

At the same instant allow another coin to drop from left fingers into hat. Be sure to time the dropping of the coin from left fingers properly with the action of the right hand in pretending to toss the coin into the hat.

"And another over here."



Reach up into the air again at another point and pretend to catch another coin from the air. This time you show the coin. You produce it by forcing out the coin which you have Thumb Palmed to your finger tips and hold it in the Production Clip position. The movement of your hand in reaching up for a coin will cover the movement of producing the coin. Figures 20 and 21.



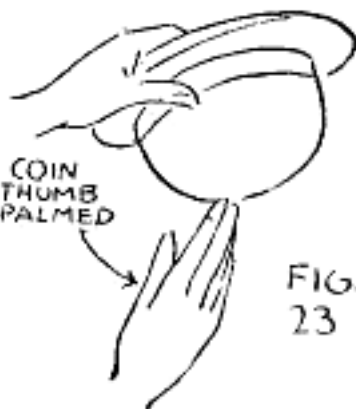
Finger Clip the coin and pretend to throw it into the hat. In reality, Thumb Palm the coin again and at the right instant let another coin drop from left fingers into the hat.

"I'm beginning to see lots of coins."

Produce the next coin from under right knee. Pretend to throw it into the hat, but Palm it and drop a fourth coin from left hand.



Now produce a coin from behind your left elbow. Raise hat with left hand and hold right hand with coin Finger Clipped under crown of hat. Figure 22 shows position of hands.



Now pretend to throw coin right through bottom of hat. As hand goes up to hat, Thumb Palm the coin again and let a fifth coin drop from left hand into hat. Figure 23.

"That one went right through."

Pretend to pick coin from air again, producing coin in Production Clip position from right hand. Pretend to throw it high into the air; in the meantime, Palm it again. Hold left arm outstretched. Follow imaginary coin with your eyes-look upward as though watching it go up and then down to hat. Pretend to catch it in hat, and at the right instant drop a sixth coin from left hand into hat. Make this as real as possible.

REMEMBER THAT PANTOMIME IS VERY IMPORTANT IN ILLUSION.

Reach out for another coin and pretend to drop it into hat, allowing a seventh coin to fall from left hand. Then repeat again and let an eighth coin fall from left hand.

You now have one coin left in your left hand and one coin palmed in your right hand.

"This is called, Easy Come, Easy Go."

Reach into the air for a coin again, and this time really drop coin from right hand into hat.

Reach into air again and pretend to grab a coin in right hand. Now TURN BODY TO THE RIGHT SO THAT LEFT SIDE IS TOWARD AUDIENCE. Pretend to throw imaginary coin in right hand high up into the air. Follow it with your eyes.

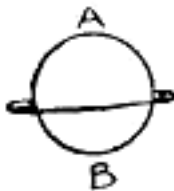


FIG. 24

Allow right hand to fall at your side. Curl your fingers up under your coat and release the five coins in the front safety pin. Now pretend to catch coin from the air in the hat and release last coin from left fingers. Keep opening of hat slightly turned from audience so that they cannot see coin fall from left hand. Figure 24 shows side of hat toward audience.



FIG 25



To learn how to get coins from safety pin easily, study the diagrams in Figures 25 and 26 carefully. Let top edge A of coins come downward. This brings edge B to the top and turns bottom edge of coat up with it. Figure 25. Push edge B down and out of safety pin with thumb. Let coins come into hand in Finger Palm position and close second, third, and fourth fingers over them to conceal them. Figure 26.



FIG 26

Turn to the left again so that you can hold back of right hand naturally toward audience.

"Every man his own mint."



FIG 27

Reach up into air after coin, and in doing so, slide a coin from those palmed in right hand into Production Clip position with thumb. Figure 27 shows coins in Finger Palm position. Put thumb over them and open fingers out as in Figure 28. Push coin out to end of thumb and index finger and close other fingers over rest of coins again. Figure 29.



FIG 28

Throw this coin into hat. Reach up into the air again and slide a second coin from right hand into Production Clip position. Throw this coin into hat. Continue to reach for coins and toss them, one at a time, into the hat until all five coins have been taken from right hand. Vary the production of the coins by producing from elbow or knee.



FIG 29

"A fine shower for the first of the month's bills."

Turn opening of hat toward audience. Reach in with right hand and scoop up a good handful. Hold hand above hat and let coins slide, one by one in rapid succession, into the hat.

"Just like a miser letting the gold run thru his hands."

Reach in again and pick up a handful of coins, this time keeping back of hand to audience. In pouring coins back into the hat, hold back a few and palm them. You will have no difficulty in doing this.

"Money, money everywhere, and to think of the years I had to work for a living."

Reach out and produce the next bunch of coins, one at a time, from various places.

Now scoop up a handful of coins from hat with left hand and let them slide back, retaining some in your hand. Produce these coins as you did before with right hand, varying your productions to keep your audience at a high pitch. For instance, you may produce a coin from a spectator's coat and toss it into the hat. Reach into hat and take out a coin.

"You see, this is just like the rest, Sir."

Catch money from here and there—from a spectator's ear, from a lady's hair—until the supply in left hand has been exhausted.

Now take hat in left hand again and hold it in front of spectator. Tell him to sneeze, and as audience is watching him, reach up under coat again and release five more coins into right hand. Finger Palm coins.

"That's a poor sneeze. Better blow."



Put right hand with coins palmed to spectator's nose, hold hat underneath, and let coins slide down into hat as though they came out of his nose. Figure 30.

This gets a good laugh and gives you an opportunity to reach under coat again for third load of five coins. Produce these one at a time from various places—a spectator's chin, or hair, from a coat, or lady's hat. Toss these into the hat as they are produced. Then reach into hat again, scooping up a handful of coins, letting them slide back, and retaining a few by Palming them in your right hand. Go up to another spectator, and holding hat under his nose, ask him to blow.

"Blow hard."

Place right hand on his nose and let coins slide into hat.

"There now, we have half a hat full of money."

Go back to stage. Pour coins out into a bowl.

"And as parting advice to the ladies, try this sometime with hubby's hat."

NOTE:

The Miser's Dream offers 30 much opportunity for variation in production that you need never lack for chances to make this effect especially interesting.

Throwing the money through the hat Is always good. Also you may pretend to put coin in mouth and blow it into hat, dropping coin from left hand to complete the illusion.



Here is a good move: Vanish coin by means of the Back Finger Clip Vanish (Lesson 21, Figure 64 to 68) in right hand. You face front with both arms extended to sides. As you vanish coin from right hand, drop a coin into hat from left hand, watching the hat as you do so. Then produce coin again at right finger tips. Figure 31.

Another arrangement is to have a safety pin with a load of coins just inside the bottom of your left trouser's leg. Boldly reach up and under cover of trouser slip coins out of pin and produce them. Or you may have a small wire clip, such as is used to hold letters together, under each lapel with a coin in each, which you can produce.

Study the Palms and Vanishes in Lesson 21. Many can be used to good advantage. Instead of pretending to place the coin in left hand, pretend to place it in the hat. Use the Invisible Thumb Palm to show the hand apparently empty every once in a while.

PUT SNAP AND LIFE into the catching of the coins. Do not let time between production of coins drag. Work fast to keep your audience keyed up to a high pitch of excitement.

THE COIN, ENVELOPE, and HANDKERCHIEF

EFFECT:

A coin with some identifying mark on it is borrowed from a spectator. It is placed in an envelope. A borrowed handkerchief is knotted. Suddenly the coin disappears from the envelope and appears in the knot in the handkerchief. The envelope is torn up and the handkerchief is untied to disclose the coin.

PARAPHERNALIA:

- 1 -- A fairly heavy manila envelope, or some other envelope which is fairly opaque. Size: 3 7-8 x 6 1-2 inches.
- 2 -- A half dollar.
- 3 -- A borrowed half dollar.
- 4 -- A borrowed handkerchief.

SECRET AND PATTTER:

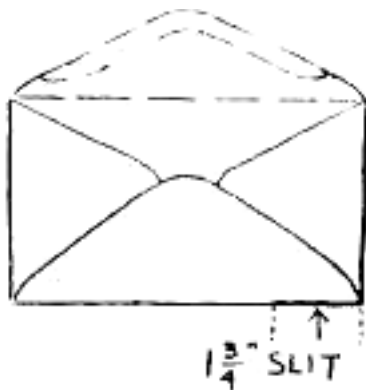


FIG. 32

To Prepare:

On the bottom edge of envelope, out a slit about an inch and three-quarters long. Do this carefully right on the fold so that it will not be noticed. A safety razor blade is excellent for cutting the envelope. Figure 32.

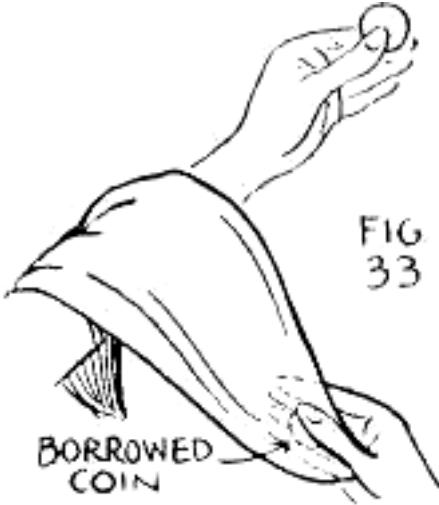
Have half dollar held by wire clip under vest or lower edge of coat, or you may have it in pocket which you can reach conveniently. If you desire, you may have coin Finger Palmed and come forward to start experiment with it already in position.

To Perform:

Borrow a handkerchief and place it over left arm. Borrow half dollar and ask owner to mark it for identification. Take coin in right hand, being careful to conceal other coin Finger Palmed. Finger Clip coin and, pretending to transfer it to left hand, Front Thumb Palm it and drop your own coin into left hand. This is the same move as you learned in your last lesson under the effect, THE COIN IN THE MAGICAL ENVELOPES.

Now allow the borrowed coin which is Thumb Palmed to slip down into Finger Palm position.

Go back to stage. Take handkerchief by corner nearest you, placing hand under it with coin and thumb on top toward audience. Hold your own coin up in left hand. Figure 33.



Draw handkerchief away from left arm. As you do so, raise index finger of right hand up and over to front of handkerchief near thumb so that it is near edge of coin and handkerchief is held between first and second fingers. Figure 34.



When handkerchief falls from left arm, it is held gripped in right hand. Borrowed coin is held between thumb and fingers and is covered on both sides by handkerchief. Figure 35.



Place half dollar which you have in left hand on table or some other place in full view. If you have an assistant, you may give it to him to hold.



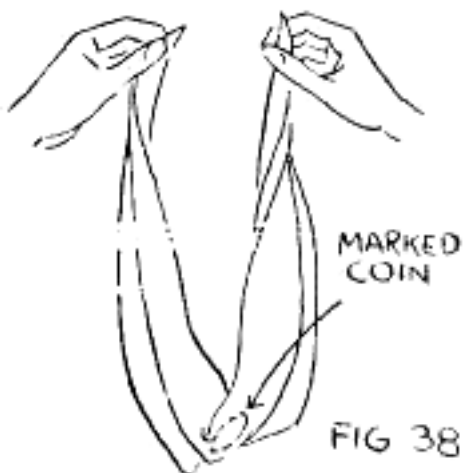
With coin held in fold of handkerchief in right hand, pick up opposite corner of handkerchief in left hand and hold as shown in Figure 36.



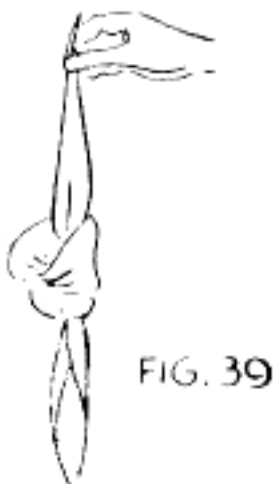
Now with a movement cause the corners C of the handkerchief to flip up over middle and fall down in front. Figure 37.

(23-8)

FIG 37



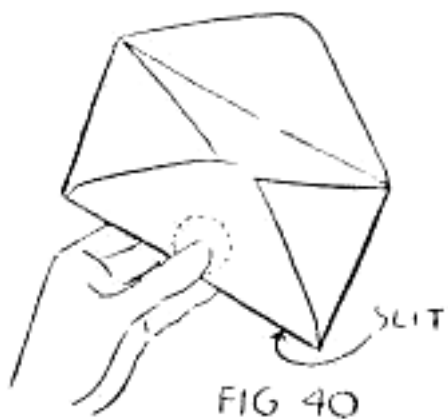
This makes a tube in middle of handkerchief. Bring two ends fairly close together. Release coin and allow it to slide down tube to center of handkerchief. Figure 38.



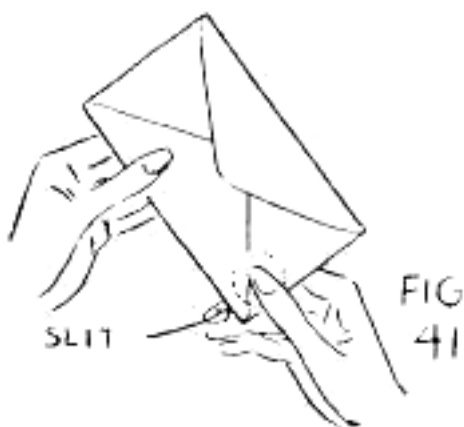
Tie a knot in handkerchief and give it to spectator to hold by one of the corners. If coin is visible in knot, pull down cloth over it a little to conceal. Figure 39.

Pick up half dollar and the slit envelope from table.

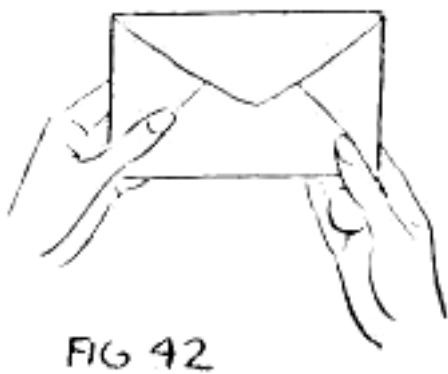
"The gentleman has marked his half dollar. He can recognise it easily, I am sure. Would you mind, sir, if I sent it away in an envelope?"



Show envelope empty and drop half dollar into it so that audience can see it go in. Coin comes to bottom of envelope. Hold it there with thumb and fingers of left hand. Figure 40.



Seal flap of envelope. Now turn it on end and let coin slide down to slit corner. Hold coin there with right hand. Figure 41.



Turn envelope straight again and let coin SLIP OUT THROUGH SLIT IN ENVELOPE INTO RIGHT HAND and Finger Palm it. Figure 42.

Take envelope in left hand. Drop coin into upper left coat pocket or right trouser's pocket, as you have been taught to do, without letting audience see. You may have a pencil in one of your coat pockets and drop coin into pocket while reaching for pencil.

"I will just mark the envelope with my secret initials."

Mark envelope and place pencil back in pocket.

"In reality, I should not have done that. I forgot that the gentleman marked his coin. Strange as it may seem, two magic marks on the same package oftentimes dissolve that which is within."

Shake envelope and listen.

"It seems rather quiet within. Sir, your coin has kissed us goodbye."

(23-9)

Tear up envelope into small pieces and drop on table.

NOTE:

A ruse to use is to paste a piece of opaque paper, cut round the size of a half dollar, in the bottom of the envelope. After you have taken coin out, hold envelope up in front of a burning candle or match and show shadow of coin within (really the opaque paper). Set fire to envelope and let it burn, finally dropping the remains onto a plate. You have apparently burned the coin.

Another clever fake is to paint a disk the size of a half dollar with Chinese White water colors, such as are used by show card writers and artists, on the inside of a white envelope. Inside of envelope may be shown with nothing in it, but when envelope is held to light, the disk shows opaque and appears to be the coin. Paint disk so that it looks like coin is lying at bottom of envelope. With a manila envelope, use a paint to match made by mixing white, red, yellow, and a touch of black.

You may also work it this way. Hold envelope to light with coin in it before you slide coin out into your right hand. Have coin in middle of envelope at bottom when you do this. Take envelope away from light and let coin slide into hand. Hold envelope in left hand and let it burn, in the meantime disposing of coin in right hand.

"But something tells me that it has not gone far."

To gentleman holding the knotted handkerchief.

"Would you mind untying the handkerchief to see whether the gentleman's coin has in some mysterious way hidden itself inside the knot?"

Spectator unties the knot and finds the borrowed coin.

"Will you please give it to the gentleman who loaned it to me and let him identify it as his coin? Remember, I do not touch the half dollar myself. Is that your coin, Sir? Which goes to show that as you give so shalt thou receive."

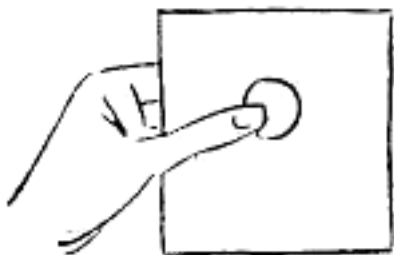
Return borrowed handkerchief or use it for another experiment.

HOW TO VANISH A COIN BY WRAPPING IT IN A PIECE OF PAPER

These methods of vanishing a coin will prove helpful at times. The moves are natural and the effect is mystifying.

Method 1:

Take a piece of paper about five inches square,--newspaper or any opaque paper will do.



Place coin a little above center of paper. Figure 43.

FIG. 43



Fold up bottom edge of paper to within half an inch of the top edge. Figure 44.

FIG 44

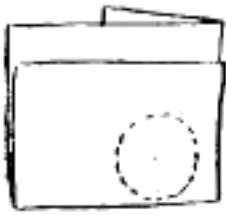


FIG 45

Fold right side of paper over in front. Figure 45.

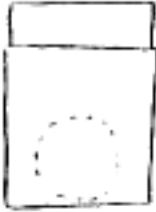


FIG 46

Then fold left side of paper over in front. Figure 46.

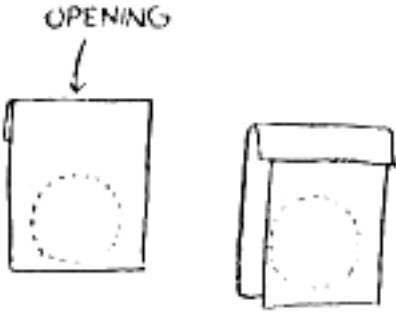


FIG 47

FIG. 48

Fold top half-inch down in front. To all appearances, the half dollar is wrapped securely in the paper, but in reality the coin is in the rear partition with an opening at the top. Figures 47 (rear view) and 48 (front view).

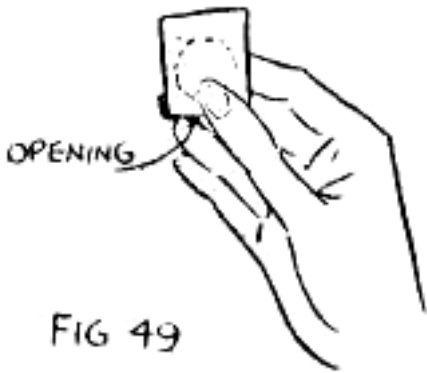


FIG 49

Turn paper over so that opening is downward and hold in right hand as in Figure 49.

If someone is near you, let him feel the coin in the paper. Then allow the coin to slide out into your right hand, Finger Palm it, and take paper in left hand. Now all that remains to be done is to get rid of the coin in one of your pockets and then tear the paper up. Or, if you desire, you may tear up the paper with the coin still Finger Palmed and then produce the coin from some suitable place.

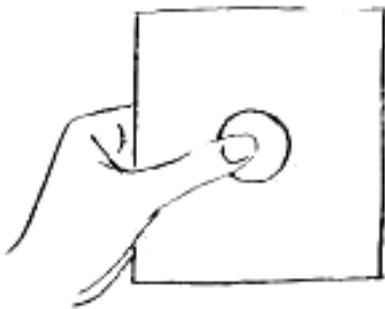


FIG 50

Method 2:

Place coin in center of paper. Figure 50.

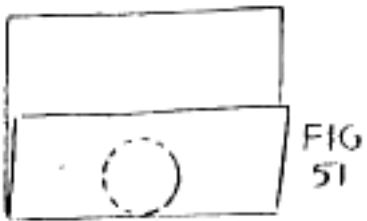


FIG 51

Fold up bottom third of paper to cover coin. Figure 51.



FIG 52

Fold down top third. Figure 52.



FIG
53

Grip right end of paper with thumb and first and second fingers of right hand. Figure 53.

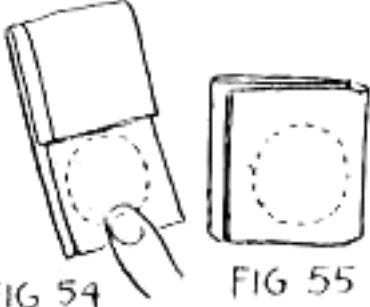


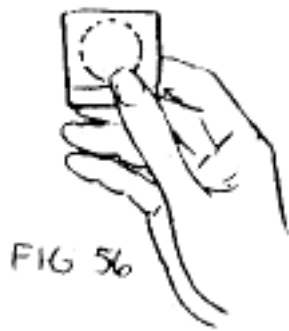
FIG 54

FIG 55

Fold over left third of paper, and as you do so, turn paper up to vertical position and let coin slip down from center of paper to bottom near right hand. Figure 54.

Now fold over bottom or right-hand third with coin in it. Figure 55.

(23-11)



As the coin is in the rear fold and near the end of the paper, it can be easily slipped out from opening into right hand in Finger Palm position. Figure 56.

Tear paper into small pieces or burn it.

THE PASSE COINS AND GLASSES

This is an excellent effect to work under artificial light and at such a distance from spectators that a fine black silk thread will not be visible.

EFFECT:

Two empty glass tumblers are freely shown. Into one five palming coins or half dollars are counted one at a time. Performer holds this glass in his left hand and the empty glass in his right hand. Upon his command, a coin leaves the left-hand glass and drops into the right one. The coins are then counted and only four remain in the left glass. Magician continues to pass the coins from the left glass to the right until all five have passed over.

PARAPHERNALIA:

- 1 -- Five Palming Coins, or half dollars.
- 2 -- A Special Palming Coin with small hole in it.
- 3 -- A spool of fine black silk thread.
- 4 -- Two glass tumblers.
- 5 -- A small black safety pin.

SECRET AND PATTERN:

To Prepare:

Figure 57 shows how the magician looks as he performs this effect. There must be no unnaturalness to suggest in any way the preparation which you make for the experiment.



Now take the small safety pin and, through the hole in the end, tie one end of a piece of black silk thread. Pin the safety pin up under the left armpit onto your coat, slightly to the rear so that it will not be noticeable. Allow enough length on your thread to reach from the safety pin thus placed to the bottom of your left coat pocket. Then tie the free end of the thread through the hole in the Palming Coin. Then place coin in left coat pocket. Length of thread varies with different performers and experience will teach you the length of thread you can work with best. Figures 58 and 59.



FIG 58



FIG 59

To Perform:

Come forward and pick up the two glass tumblers from the table. Show glasses to be empty.

From your right coat pocket take five coins and count them, one at a time, into the left glass. As you do this, turn your left side away from audience.



Reach into left pocket with left hand and take out the coin on the thread. Finger Palm this coin, curling your fingers a little to conceal coin. Figure 60.

Pick up glass with coins between thumb and first finger of left hand. You will have no difficulty in doing this with coin Finger-Palmed in hand. Pour coins into empty right hand, then set glass down with right hand.



Drop coins into left hand on top of the threaded coin. Place them all at base of first finger and hold in place with left thumb. Figure 61.



Remove top coin. Curl second, third, and fourth fingers of left hand inward and place coin in Curled Finger Tip Palm position (Lesson 21, Figure 10). Do this quickly with the aid of your right hand, also using it as a screen. Figure 62.



Pick up empty glass at right-hand side. Hold it near the bottom between thumb and first finger of right hand. Show palm of hand freely. Figure 63.

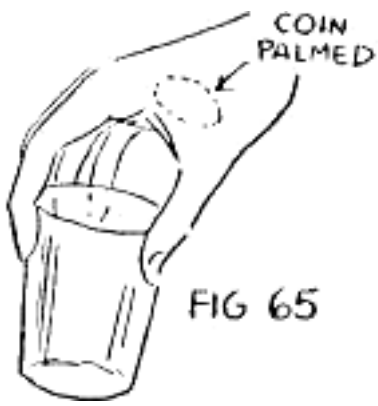
"I use this glass so that you can see through it."



Talk to people on right as you say this and show the glass. Now turn toward left and, as you do so, perform a CHANGE OVER in this way: Place right hand, back toward audience, with glass in front of left hand. Under cover of this screen, straighten second and third fingers of left hand with coin and force coin into the palm of right hand. Palm coin in regular manner, gripping it by its edges. Figure 64.

Right hand continues in its movement to the left without a pause, and the audience is not aware that you have done anything unusual with it. Now say to the people on the left,

"That is, you can see through the glass, and NOT the trick."



Swing back to front. Now grip middle of glass with left thumb and forefinger and raise right hand to position shown in Figure 65.

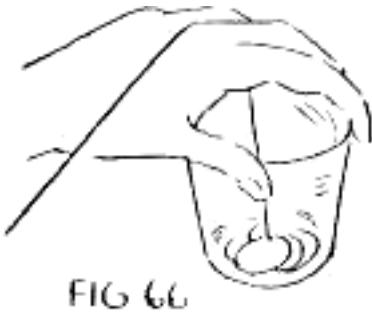
This brings the palmed coin up above the glass.

Release hold on glass with left hand and bring glass over to your right side. Keep back of right hand toward audience.

(23-13)

"As I said once before, I have five coins. I shall count them again, one at a time, into the glass. One-two-three-four - five."

Count the coins out of your left hand, dropping the threaded one last as the fifth coin into the glass. Thread comes up over top of glass on side nearest you.

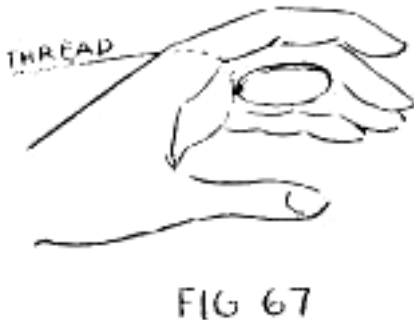


Pick up glass with left hand over the top of it, getting thread between second and third fingers. Let thread fall over back of hand to bottom edge of sleeve. Figure 66.

Glass must be held at such distance from the body to allow enough slack in thread so that coin will remain at the bottom.

Hold the two glasses about three feet apart in position shown in Figure 57.

"Now, watch. Five coins in this glass and none in the one over here. I'll pass one across. One - two - three, Go!"



Shake the left-hand glass up and then down for a few inches. At the same time, move the glass far enough from the body to make the thread taut and to pull the threaded coin up into Finger Palm position. Keep thread taut to hold coin in position. Figure 67.

Turn and look at right-hand glass. Let the Palmed coin fall from right hand into glass. The effect is, of course, that one coin has gone from the glass on the left to the one on the right.

Set right-hand glass on table and reach over, taking left-hand glass at the middle with right hand. Move left hand from top of glass to bottom, now holding it between thumb and first finger. Hold threaded coin firmly in Finger Palm grip. Now pour coins into right hand.

Set glass on table and count coins, one at a time, into left hand again on top of threaded coin. Be sure to conceal this coin until it is covered with another.

"One - two - three - four. One coin has passed over into the other glass."

Under cover of right hand, adjust the coins as you did before, placing one in Curled Finger Tip Palm position. Pick up right-hand glass.

"If this glass were made of tin, you couldn't have seen the half dollar pass over."

Perform the CHANGE OVER now by bringing glass in front of left hand and forcing coin into palm of right hand.

"That's the advantage of glass."

Bring glass back to right side and hold ready to release coin from palm of hand.

Drop coins, one at a time, from left hand into other glass. The threaded coin goes in last as the fourth coin.

"One - two - three - four."

Show left hand empty. Bring thread up through fingers again and pick up glass at top.

"It's funny what happens when I talk to the coins in Persian. Alley - oop!"

Shake glass up and down, drawing thread taut and thus getting threaded coin into Finger Palm position again in left hand. Look at right-hand glass and let palmed coin fall into glass from right hand.

"Another coin has passed over."

Set right-hand glass on table, then pour coins into right hand as before. Set left-hand glass on table and count the three coins into left hand, placing coins on top of threaded one.

"One - two - three."

Under cover of right hand, push the uppermost coin into Curled Finger Tip Palm position and then force it into Palm position in right hand. Let right hand drop to side as you count the three coins in left hand into the left-hand glass again.

"One - two - three."

Pick up glass in left hand again as before, with thread adjusted. Then pick up right glass.

"In case I should forget how to talk Persian, I have learned how to talk Chinese to the coins. Sprechen Sie Deutsch?"

Shake glass up and down, drawing thread taut and forcing coin into left hand. Then let palmed coin fall from right hand into glass.

"There goes another. If you look close enough, you can see them jump over."

Repeat routine of pouring coins from left glass into right hand and then counting them back into left hand.

"One - two."

Do the CHANGE OVER and palm top coin in right hand as before. Count the TWO coins in left hand into glass. Then pick up left glass with thread in position and right glass in right hand.

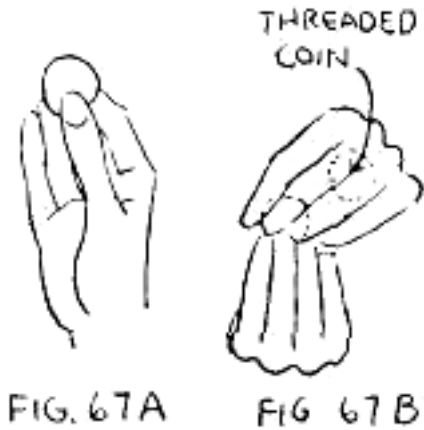
"Parley voo Fransay?"

Shake glass and coin comes up into left hand.

"Wee - wee."

Drop coin from right hand into right glass.

"So that leaves us with ONE coin in this glass."



Pour the one coin into right hand. Hold coin up at finger tips as in Figure 67A. Set glass on table. Pretend to take coin with left hand. When it is screened with left hand, let it fall into Palm position in right hand. Figure 67B.

Carry left hand away as though holding coin. Then open hand and show threaded coin. The audience, of course, thinks that this is the coin which you took out of the glass.

"I shall drop the last coin into the glass."

Drop threaded coin into left-hand glass with thread in position between fingers. Pick up right-hand glass with right hand.

"Now watch the last coin closely. Alley - oop!"

Shake glass and cause coin to come up into hand, leaving the glass empty.

"Alley - ga - zam!"

Let coin fall from right hand into right glass.

Set right-hand glass on table, then show left-hand glass empty and set it also on table.

"Traveling this way is better than street cars."

Pick up right-hand glass and pour coins into empty glass. As you do this, turn right side toward audience. This gives you a chance to drop threaded coin into left coat pocket and thus dispose of the evidence.

NOTE:

For closer work, a human hair may be used instead of the thread. Experiment with a long hair, graciously given to you by some lady friend who still retains her long tresses.

THE PASSE COINS FROM HAND TO HAND

An especially good effect for close work and entirely impromptu so that you may perform it at the dinner table, at your club, or while entertaining at a party.

EFFECT:

Magician shows four coins in his left hand. His right hand is empty. He then closes both hands and reopens them to show three coins in his left hand and one in his right. Performer continues to close the open his hands, each time showing one less coin in his left hand and one more in his right, until all four coins have passed over into his right hand.

PARAPHERNALIA:

- 1 -- Four. Palming Coins.
- 2 -- A Palming Coin Shell.

This shell fits over a Palming Coin without changing the appearance of the coin at all. When shell is on coin, it looks like one coin. When shell is taken off coin, it looks like you hold two coins.

This shell has many uses in the vanishing and producing of a coin. As it has the appearance of a coin, the audience believes it to be a coin. Precaution must be taken, however, not to let audience see back of shell.

SECRET AND PATTTER:

To Perform:

Have a table in front of you on which to lay coins as occasion requires.

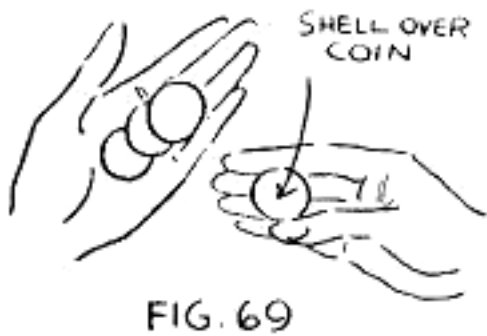
Have the four coins in your right hand. Over one of the coins have the shell.

"This experiment is done with four coins. I think it was originally founded cm that famous axiom, 'You have the money, but can you keep it?' Anyway, keep your eyes on the four coins."

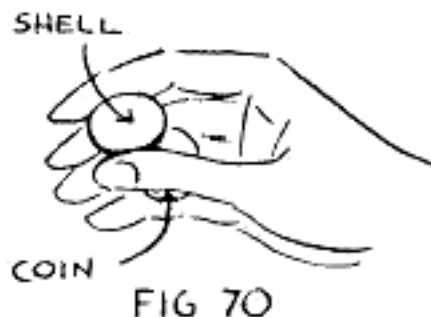


Count coins one at a time into the left hand. Hold them spread out over fingers with thumb on top. Have coin with shell on top with front of shell exposed. Show coins to spectators. Figure 68.

Show right hand empty.



Take coins in right hand again and then lay three of them on left hand, one at a time, in position shown in Figure 69. Retain coin with shell in right hand with shell uppermost.



Let coin rest on second and third fingers of right hand. Grip edge of shell between thumb and first finger. Raise thumb and forefinger, thus lifting the shell free from the coin. Figure 70.

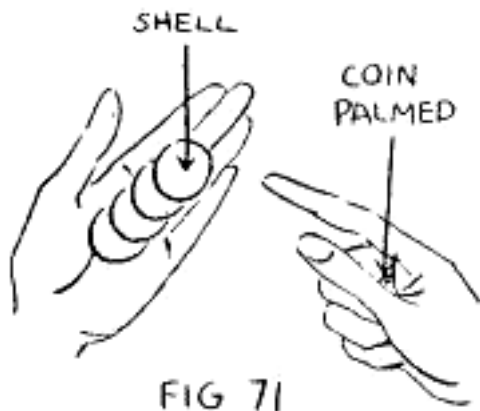


FIG 71

Place shell with other coins on left hand and retain fourth coin by Palming it in right hand. Audience believes that you placed four coins on left hand. Figure 71.



FIG 72

Close both hands, and in doing so, allow shell to slip over top coin in left hand. Hold hands about two feet apart. Figure 72.

"It is difficult for money to stay in one place. First, I have it, then you have it, and then someone else gets it. For instance, I have four coins in my left hand."

Open left hand to show only THREE coins. The placing of the shell over one coin eliminates a coin.

"That is, I did have four coins until the money began to circulate, and now I have only three."

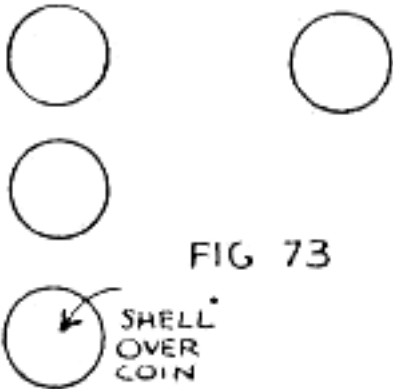


FIG 73

With the left hand count the coins onto the table, one at a time, in a row. Put the coin with shell down first as Number One. Figure 73.

"And it seems, the other has circulated over to my right hand."

Place coin from right hand down on table also.

Pick up the three coins which you placed on table with your left hand, this time taking them up with right hand. Place them one at a time on left palm again. When you pick up coin with shell, however, place in right hand again as described above (Figure 70). Then place shell in left hand as a coin and retain the coin Finger Palmed in right hand.

"I place the three coins back in my left hand, and pick up the other again in my right hand."

Pick up coin on table with right hand. Be careful to keep Palmed coin concealed while you take coin from table. Now close both hands again as before. The shell slips down over uppermost coin again, leaving two coins in left hand.

"Note carefully, and perhaps you will see the next one pass over—that is, you will see if you have psychic eyes."

Open left hand and show two coins.

"It went. And so now we have--one, two."

Count coins onto table again, placing coin with shell down first as Number One. Open right hand.

"And over here—two coins."

Lay coins from right hand on table in a row.

Pick up with right hand the two coins placed down by left. Place one coin in left hand. Then Palm out coin from shell as before, retaining it in right hand, and place shell in left hand as second coin.

Pick up the other two coins with left hand.

Close hands and let shell cover remaining coin in left hand

"Now we have a fifty-fifty game—two in my left hand and two in my right. That is, that is what we had before another one slipped away."

Open left hand and show single coin. Open right hand and show three coins. Count them out onto the table.

"One - two - three."

Cover coin in left hand with right hand and lift off shell, carrying it away in right hand. Audience does not suspect anything for they saw one coin in left hand and still see one. Now hold up coin and look at both sides.

"For this last one I take extra precautions."

Reach into right coat pocket. Leave shell there and bring out right hand as though holding a pinch of salt in fingers.

"I put a little salt on his tail..."

Pretend to sprinkle salt on coin. Now apparently secure coin in left hand by closing hand. In reality, Thumb Palm the coin in right hand and close empty left hand.

"And keep him by his lonesome over here."

Motion to left hand. Allow Thumb Palmed coin to slip to Finger Palm position. Then pick up the three coins from table with right hand and close your hand over them.

"I guess the salt wasn't strong enough."

Open left hand and show coin gone.

"This one, too, has left, and we find it over here with the others."

Count coins out onto table with right hand.

"One - two - three - four."

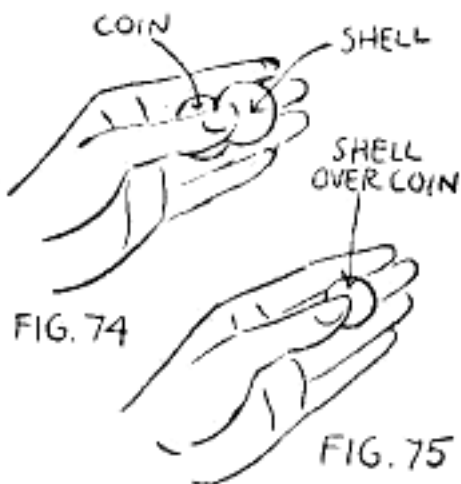
NOTE:

Coins may now be handled and shown freely as the shell has been disposed of.

The shell coin offers many interesting variations in Coin Magic. It may be introduced into Coin Sleights with excellent results.

Here are two good effects, using the shell:

Take two coins, one covered with the shell. Show coins freely and show hands empty. To all appearances place both coins in left hand, but in reality place one coin and the shell, retaining the other coin Finger Palmed in right hand (as you did in the preceding effect). Figure 74.



Call attention again to the TWO coins in left hand. Turn back of hand to audience and slip shell over coin in left hand. Now expose palm of hand and show ONE coin. Figure 75.

Now reach down behind your knee and produce coin from right hand, or from left elbow. The effect is that the coin vanished from left hand and appeared again at another place.

Another effect is this one, in which you show a coin and the shell as TWO coins. Place them in left hand as in Figure 74. Show them freely, then cover coins with right fingers, pretending to carry one away. In this move slip shell over coin as in Figure 75. Then vanish imaginary coin from right hand, and show hand empty.

Now pick up coin with shell in right hand and vanish by Thumb Palming method. Drop coin into upper coat pocket.

Open left hand and show that coin has vanished.

If you wish to produce the coins again, do not drop coin with shell into pocket. Keep in right hand and produce it from behind knee as one coin. Place it in left hand, retaining shell in right hand, and produce shell from left elbow as second coin. Place shell also in left hand as coin.

* * * * *

LESSON 24

Eggs! Eggs! You are going to learn Egg Effects in the next lesson. I believe you are ready now for these interesting effects and so here are two mighty good ones with lots of good fun in them.

1 -- Humpty Dumpty Outdone. A spectator places a real egg into a handkerchief. He then is asked to feel of it through the handkerchief and to squeeze it hard with his hand. The egg breaks. Magician asks spectator to take egg out of handkerchief. Spectator is, of course, reluctant to do this because of the mess caused by a broken egg. He finally does, however, and takes the egg out whole as it was in the beginning.

2 -- A small cloth bag is shown empty and is given to a boy to hold. A girl is given a handkerchief to hold by its four corners. Magician drops an egg into the handkerchief. Suddenly this egg vanishes and appears in the bag which the boy holds. Then mysteriously this egg vanishes from the bag. Magician looks for it in the boy's coat and instead produces a pair of lady's stockings and other laugh-provoking articles. Finally the egg is found to have returned to the bag.

(23-21)

LESSON 24

Eggs, as apparatus, are the subject of this lesson--a delicate subject, and one which must be handled with care. I have, therefore, very carefully and thoroughly analyzed the effects in this lesson. I have made them simple and clear so that you can learn to do them easily and quickly.

Eggs have played a big part in successful Magic. The extremely puzzling effect which the experiments with eggs have on the audience are due to the nature of the material used. Eggs are so fragile and difficult to handle that spectators marvel at the Magician as he produces eggs and vanishes them in the most nonchalant manner.

In this lesson I teach you how to handle one egg at a time. Later on I teach you how to produce a quantity of eggs from an empty hat--an experiment which keeps an audience roaring with laughter.

Comedy is, of course, closely associated with eggs. In these effects which you learn today, there is opportunity for much good comedy.

HUMPTY DUMPTY OUTDONE

This effect used to be quite a favorite of mine as it is a bit unusual and very puzzling.

EFFECT:

Performer passes his handkerchief and an egg around for examination, then asks a spectator to bring them back to him and assist him in the experiment. Magician then grasps handkerchief by the corners and tells assistant to drop egg into it. The egg, of course, falls to the center of the handkerchief. Spectator is told to feel of the egg through the handkerchief, then to BREAK the egg. The crushing of the egg is heard and all believe it to be smashed. Performer then asks assistant to reach inside the handkerchief and remove the egg. Assistant hesitates for a broken egg is rather a messy thing to pick up. He finally does reach in, however, and brings out the egg wholly restored to the amazement of himself and the rest of the spectators. Handkerchief is opened wide and shown empty.

PARAPHERNALIA:

1 -- A man's white handkerchief. This should be as heavy and as nearly opaque as possible. A freshly laundered handkerchief will be more satisfactory for this reason.

2 -- An egg.

3 -- An egg shell. This is easily prepared by making a small hole in each end of an egg, inserting a toothpick to break the yoke, and then expelling the contents through one hole by blowing through the other.

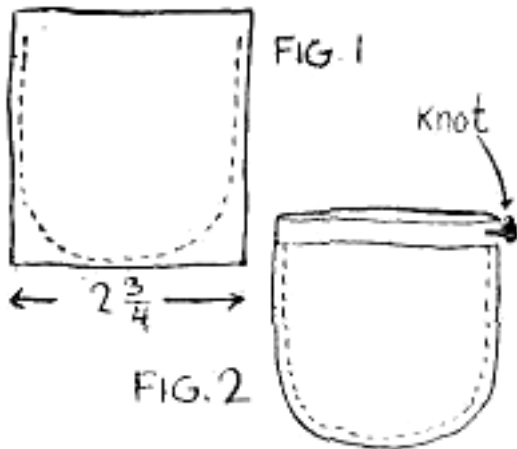
4 -- A small piece of white cloth. Part of an old handkerchief will do for this. Size: about 6 1/2 x 2 3/4 inches.

5 -- A pin, a small piece of white string, and a needle and white thread.

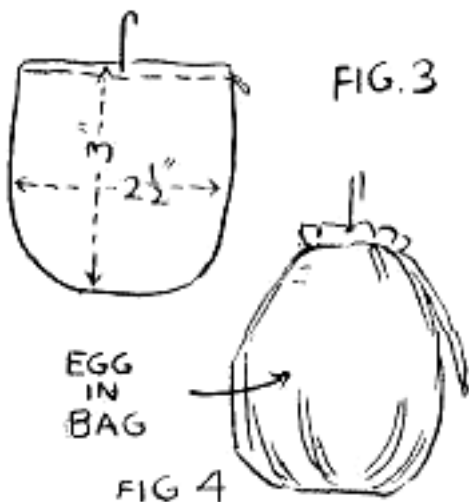
SECRET AND PATTERN:

To Prepare:

Make a small bag of the white piece of cloth. This must be large enough to hold the egg shell.



Fold the cloth over in two to make the bag about 3 1/4 inches long. Sew the two edges together as shown in Figure 1. Then trim off the edges close to the seam. Fold the top edges down all around about three-eighths of an inch, insert the white string under the fold, and sew this fold down. Tie a knot in the ends of the string close to the bag. Figure 2.



Turn bag inside out. Take the pin and bend the end of it over about three-eighths of an inch. Run it through top edge of one side of bag, pushing it up until head is close to bag on inside and little hook extends up. Figure 3. Place empty egg shell inside the bag and draw the string tight to close bag and keep fragments of shell, when it is broken, from falling out. Tuck loose ends of string into inside of bag. Figure 4.



Take bag and insert point of pin into upper edge of upper left vest pocket. Figure 5.

Your coat covers bag completely and no one is aware, of course, that you have this arrangement of the bag under it.

Have handkerchief and whole egg in some convenient place, and you are ready for the experiment.

To Perform:

Come forward with egg and handkerchief.

"You have no doubt, heard of the famous egg called Humpty Dumpty. 'Humpty Dumpty sat on a wall.' Well, this is one of his descendants."

Show the egg, and hand it to a spectator.

"Would you mind, sir, holding Humpty Junior?"

Turn to another spectator and give him the handkerchief.

"And would you mind giving this handkerchief the once over? I think you will agree that there is enough material to make Humpty a nice wedding dress in case he ever needed one."

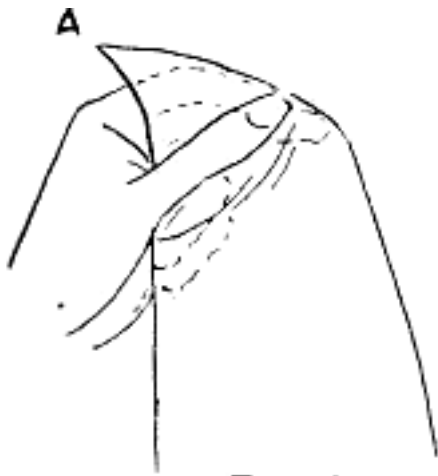


FIG 6

Take handkerchief from gentleman and hold it in left hand as shown in Figure 6. THE WAY YOU GRIP THE HANDKERCHIEF IS VERY IMPORTANT. Hold it against base of thumb with second, third, and fourth fingers gripping it tight on under side. Top edge is gripped between index finger on under side and thumb on top. Handkerchief must be drawn taut between the two grips.

To spectator holding egg:

"Will you please come up with me here and act as guardian over the egg?"



FIG 7

Turn your back to the audience and walk towards your stage or place where you are performing. The moment your back is turned, reach inside of coat with right hand. Grasp head of pin on bag firmly between tips of thumb and first finger. Remove bag from vest. Figure 7.

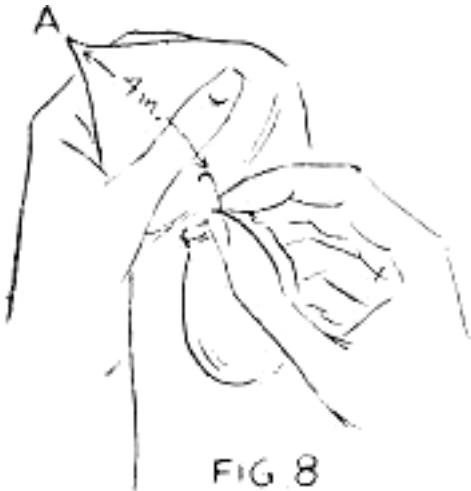


FIG 8

Bring left hand with handkerchief in front of you and quickly pin the bag to handkerchief. Insert pin about four inches from upper corner of handkerchief. It is easy to do this if you hold handkerchief taut in your left hand. Perform this move of attaching bag very quickly. Figure 8.



FIG 9

Extend left arm a little toward left so that audience sees handkerchief and back of left hand. They cannot see bag with egg shell as it is on palm side of hand. Figure 9.



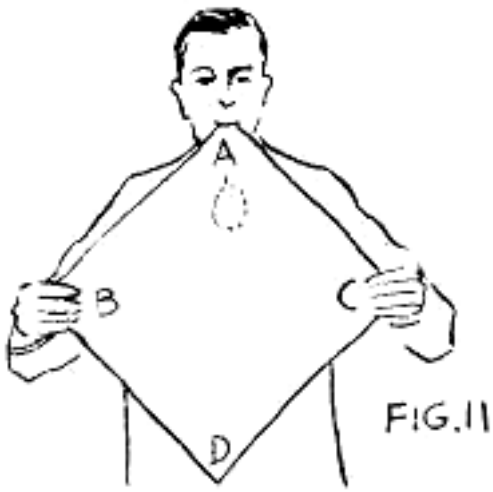
FIG 10

Now you have reached the place where you are going to perform and turn left to face your audience. Be careful not to expose bag as you turn. Gradually in making your turn, bring your left hand in front of you with back of it toward audience. Figure 10.

To all appearances you merely took the handkerchief from the spectator who examined it, went back to the stage, and then turned around to start the experiment.

The spectator holding the egg has followed you. Have him stand to your right and a little forward so that he cannot see the bag on the back of the handkerchief. Keep the handkerchief near your body to screen bag.

"I shall ask you, sir, to stand right there."



Take upper corner A between your teeth. Hold out the two side corners B and C with your right and left hands. This is done to show the handkerchief empty without saying that it is. The little bag is, of course, concealed behind the handkerchief. Figure 11.

(24-3)



FIG. 12

Bring corners B and C up with each hand to corner A. Grasp corner A with left forefinger and thumb. Figure 12.

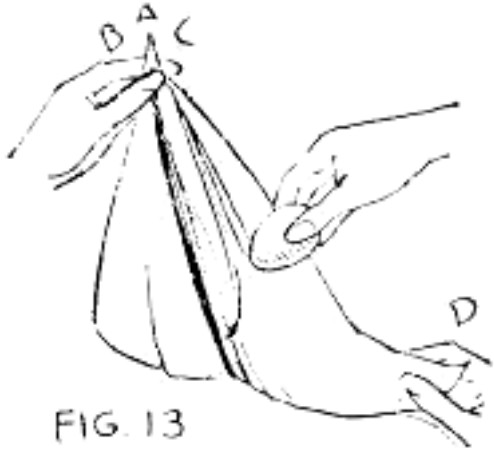


FIG. 13

Remove corner from mouth, holding the three corners A, B, and C with thumb and first two fingers of left hand. Grasp corner D with right hand. Hold handkerchief as shown in Figure 13.

Ask assistant to place egg in the handkerchief as shown in illustration.

"You are quite certain, sir, that you have an egg? All right. Then place the egg in the handkerchief."

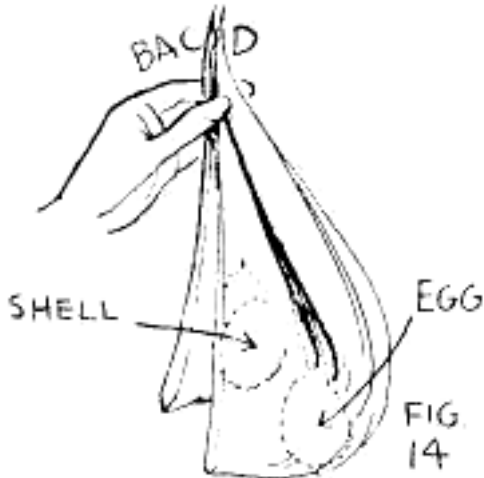


FIG. 14

After assistant has done this, bring up corner D and place it with the other three corners. Grasp it in left hand as in Figure 14. This illustration also shows position of the bag containing the egg shell and the whole egg.



FIG. 15

Place right hand around center of handkerchief which is hanging down and the egg in it. This brings egg into palm of right hand and thumb of right hand behind egg shell. Figure 15.



FIG. 16

With right thumb push the egg shell in the bag upwards. Be careful to conceal whole egg in right hand by turning back of hand to audience. The effect is that you are merely grasping one end of the handkerchief with your right hand and the other end with your left, and that the egg is brought up under the handkerchief between your hands. Figure 16.

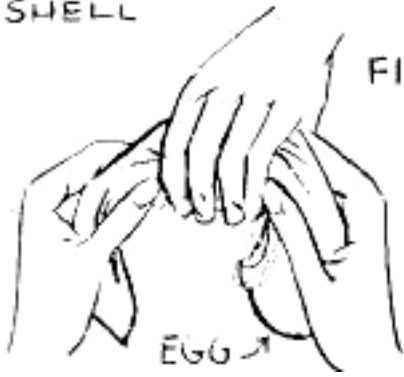
"Will you please feel it now and see that the egg is safe within the handkerchief?"

Have assistant feel the egg. He believes, of course, that he is feeling the egg which he placed there. The audience, too, believes this.

"Please break the egg. You needn't have any fear of the consequence. It is wrapped in the handkerchief, and as it's my handkerchief, all is well. So just go ahead and break."

SPECTATOR
BREAKS
SHELL

FIG 17



Have assistant grasp egg shell and break it. The crushing of the shell is heard by the assistant and the audience so that they do not doubt that the egg has been broken. Figure 17.

(24-4)

"There certainly isn't any doubt about your breaking the egg."

Drop handkerchief again to position shown in Figure 15. Then release hold with right hand and hold handkerchief as in Figure 14. Now open corner D a little with right hand.

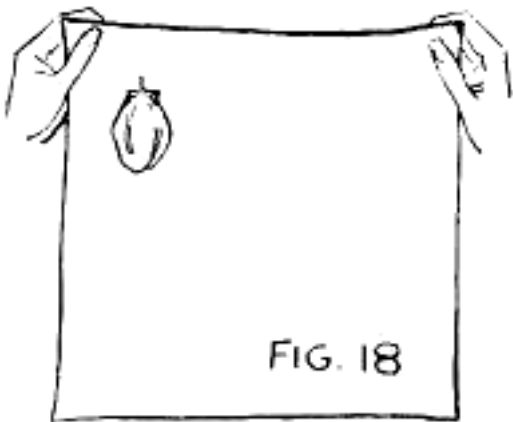
"Will you please reach inside the handkerchief and take out the egg? You would, no doubt, like to have it as a souvenir for this momentous occasion of our little tete-a-tete."

This gets a laugh from audience as they think egg is broken and a mess inside the handkerchief. Assistant, too, usually hesitates about reaching in.

"Of course, you remember that old Humpty Dumpty fell off a wall and all the king's horses and all the king's men couldn't put Humpty Dumpty together again. Personally, I don't see what horses had to do with it--unless it was a horse on the king, as we commonly say."

Assistant reaches into handkerchief and, to his surprise and the surprise of everyone, removes the egg whole.

"However, Humpty Junior is different. He lives in this more modern age of flippers and flappers, so a mere squashing means nothing in his young life. He just pulls himself together again. I believe you will find the egg fully restored."



As you say this, hold corner A with thumb and first finger of left hand and corner B with right hand. Pull hands apart, allowing corner C to drop down. Be sure to have little bag at back of handkerchief. Hold handkerchief spread out before audience to show it empty. Figure 18 shows view nearest to performer and away from audience.

Fold up handkerchief with bag concealed inside and place it aside or in pocket.

"I know, sir, that you will find this experiment very useful should you order scrambled eggs and then suddenly decide that you want them soft boiled."

If you desire, you may break egg into a saucer to prove that it is a real egg. Or you may just put egg aside and start with another trick, or you may use this egg for the next experiment with the egg bag.

NOTE:

A borrowed handkerchief may be used for this experiment. If you use a borrowed handkerchief, palm off the little bag from it after you have completed the effect. You can crush the bag up small in your palm as the egg shell is broken. As you go to return handkerchief, held in left hand, place bag in your pocket with your right hand.

THE EGG BAG

The experiment in which an egg disappears and reappears in a small cloth bag has come down through the ages to us. It has been worked by many methods and in various versions, and it has always been a popular number on magicians' programs. It affords the audience much amusement, especially if there are children present.

This version which I teach you is fool-proof and very effective. In combination with it you also learn how to vanish an egg from a handkerchief and how to produce funny articles from the coat of the boy who is helping you. The handkerchief and egg bag vanishes can be applied to other articles as well as an egg -- articles, such as a watch, a ball, a glove, etc. The production of articles from the boy's coat gives you a good chance for comedy. Any number and variety of articles may be produced, once you have mastered the principle of getting a "load" of articles up under the back of his coat for production.

EFFECT:

Performer gets a boy and girl to assist him. He shows a small cloth bag to be absolutely empty and gives it to the boy to hold. He then shows a colored handkerchief, brings its four corners together and asks the girl to hold them. Magician now shows an egg and drops that into the handkerchief. The little assistants feel the egg to make sure it is there. However, when performer takes the handkerchief into his own hands, the egg suddenly vanishes. Next the egg is produced from the bag held by the boy. Magician replaces the egg in the bag and then mysteriously causes it to disappear from the bag. A suspicious movement toward his right trouser's pocket by the performer leads the audience to suspect that he dropped the egg in his pocket. The excitement has started and the performer must turn out all his pockets to satisfy the crowd that they are empty. And great is the bewilderment of the audience when the egg is now found in the bag again. Magician now gives an explanation of the effect, with the result that the audience knows less than ever. This explanation is merely a ruse so that experiment can be concluded in a most puzzling manner. Suddenly while performer holds the egg, he is surprised to find that he does not have it. The boy and girl deny that they have it. Magician pats the boy's coat and feels around for the egg. He reaches in suddenly and pulls out from the boy's coat a lady's stocking, then a pair of baby's stockings, and finally some baby clothes.

PARAPHERNALIA:

1 -- Two eggs.

2 -- Two colored opaque handkerchiefs, exactly alike. The best size is 17 inches square. Get ordinary colored bandanna handkerchiefs. Launder them.

3 -- A piece of colored flannelette or some other soft, opaque material for the egg bag. I use a dark red material for my bag, but you may use any dark color you desire.

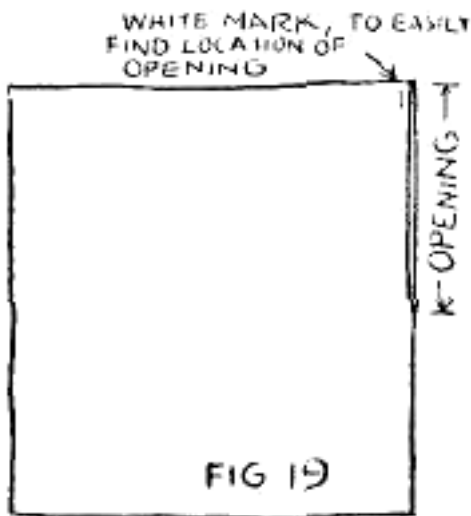
4 -- A needle and thread (thread as near same color of bag as possible, or darker).

5 -- Pins.

6 -- A lady's stocking, preferably bright colored. A pair of baby's stockings. Some small baby clothes, such as a dress, a shirt, and a baby bonnet.

SECRET AND PATTERN:

To Prepare:



HANDKERCHIEF--

Take the two colored handkerchiefs and sew them together, carefully matching the edges and sewing close to the edges. Half the length of one side leave an opening between the handkerchiefs. At corner of handkerchief near this opening sew a mark with white thread, pointing parallel with the opening so that you can easily find it. Sew this mark on both sides of the double handkerchief. Figure 19.

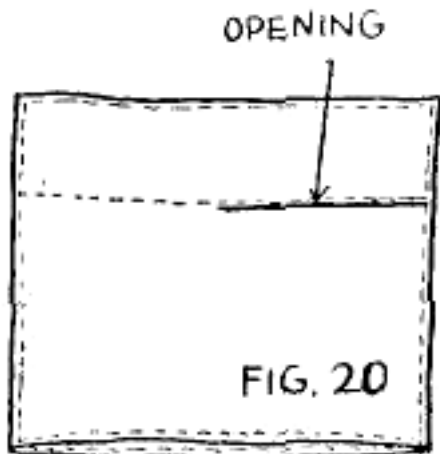
Wash and iron the handkerchiefs to remove their stiffening and make them soft and easy to handle.

EGG BAG--

This is easy to make. It is just a small cloth bag with one side double. The size is 9 inches wide by 8 inches deep.

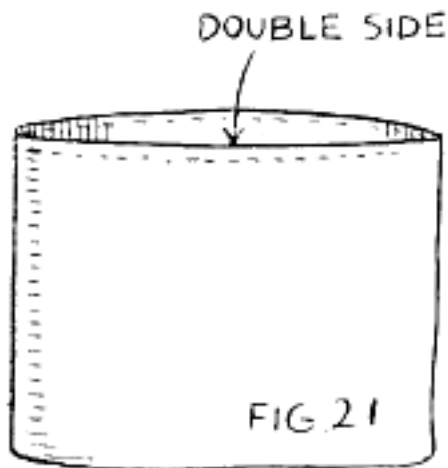
Cut out one piece of cloth, 10 x 17 inches, and another, 10 x 8 1/2 inches.

Hem the edges all around to keep them from raveling, turning them about a quarter of an inch. Fold the larger piece of cloth in two. The smaller piece will now exactly fit over the larger doubled piece. Place smaller piece on the folded piece and sew carefully around three of the sides, leaving the fourth side free for the opening of the bag. Now sew top of smaller piece to top of side of bag nearest to it. Use thread of the same color or a little darker than the material, never lighter.



Now measure up 2 1/4 inches from the bottom of the bag. Sew across the bag on this line, catching the smaller piece of cloth and the side of the bag nearest to it. Cut a slit four inches long in the smaller piece of cloth, just above the stitching. Sew the edges of this opening to prevent raveling. Figure 30.

(24-7)



Turn bag inside out. This brings trick opening on inside of bag. Figure 21 shows bag as it looks to audience.

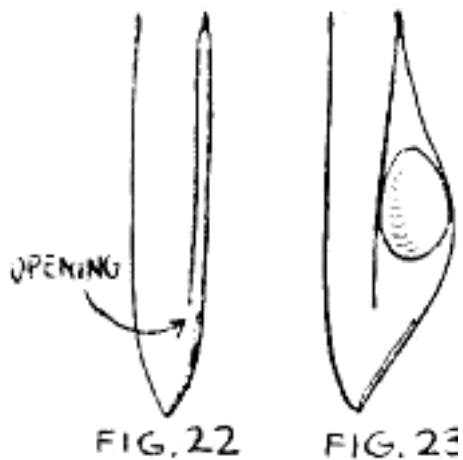
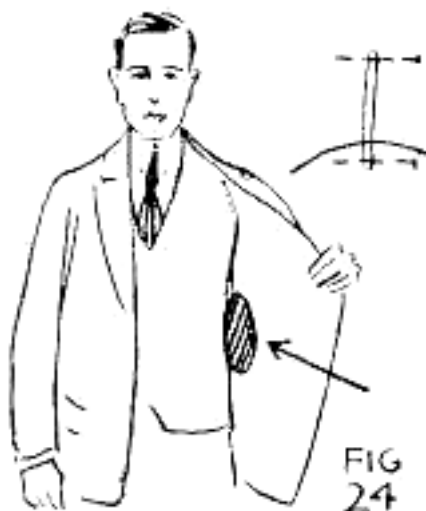


Figure 22 shows trick opening inside of bag. You notice that top of extra partition of bag is sewed to top of one side of the bag proper. About one-third way up from bottom of bag this partition is again sewed to side of bag, except for the four-inch opening which you left above the stitching. If an egg were inserted in the trick opening it would come into position between partition and side of bag as shown in Figure 23.

BODY LOAD--

The articles you are going to produce we shall call the Body Load. Take the baby bonnet, shirt, and dress, and roll them up tight. Around this bundle wrap a pair of baby's stockings. Then around all this wrap the lady's stocking and hold the end in place with a pin. This gives you a small compact package which is easy to unwrap when the pin is removed.

On edge of bundle fasten a pin. Through middle of pin place a loop of black thread about an inch or two long. This thread should be strong enough to hold the bundle but not so strong that it cannot be broken easily when pulled.



Pin other end of loop to left side of vest, high enough up so that bundle hangs in the hollow of the waist. When coat hangs down naturally this bundle cannot be seen. Figure 24.

The detail diagram at the upper right corner of Figure 24 shows the arrangement of the pin on the end of the bundle, the loop, and the pin on the vest.

Now to get ready for your experiment--Have the body load in place. Put an egg into the trick opening in the egg bag, turn bag upside down and let egg drop to top of bag, directly above trick opening. Egg is now between partition and one side of bag at the top. Fold bag and lay it aside, being careful that form of egg does not show. Have the other egg in right coat pocket. Fold prepared handkerchief and have it handy. If you are doing a club show, have handkerchief and egg bag in your grip, and all you have to do is to reach in for them when you need them.

To Perform:

Come forward with prepared handkerchief.

"I want a nice little girl to hold this magic handkerchief."

Pick out some little girl in the audience and give her the handkerchief to hold.

"That's it. Hold it up high. Now, can I get a boy to hold this egg?"

Reach into pocket and take out egg. Give it to boy.

If you desire, you may produce the egg in this way. While attention is directed to the girl holding the handkerchief, reach into your right coat pocket, palm the egg, and then produce it from a lady's hair or some gentleman's ear. Keep back of hand uppermost until production is made so that egg will not be exposed. Productions of this kind, of course, add to the comedy of an effect. As you take the egg, say,

"Pardon me, but may I use this egg?" Then give egg to boy and say,

"Hold the egg up high. Can everyone in the back see? Well, maybe you had both better come forward a bit."

With a hand on each of your little assistants lead them to the stage. Some children hesitate about coming up, so you must help them along with little remarks and a little leading.

Place the girl at your left and the boy at your right. Ask their names and introduce them to each other. Let us assume that her name is Frances and his name is John.

"I don't suppose you have ever held a magic handkerchief before, have you, Frances?"

Unfold the handkerchief and hold it by two corners, showing both sides.

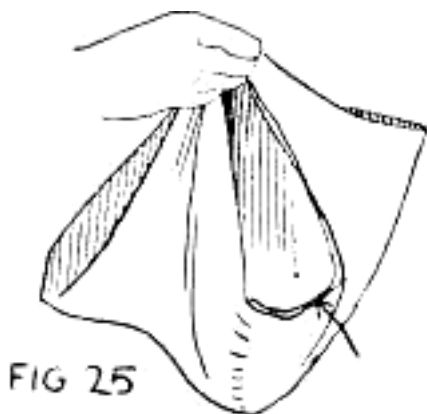
"There isn't really any difference between a magic handkerchief and the kind we usually have as far as looks are concerned. The only difference is that when you tell it to do something, it will do that thing. If I should drop this handkerchief on the floor and tell it to dance, it, being a magic handkerchief, would have to dance. That would be rather funny, wouldn't it, Frances, to see a handkerchief dance?"

Gather up the four corners of the handkerchief this way: First get handkerchief into position between your two hands so that white thread mark is in left hand and opening between handkerchiefs is on top. Right hand holds the other top corner.

Now place the right-hand corner over with the left, bring up the lower right-hand corner and finally the lower left-hand corner. Hold all four corners in your left hand.

Figure 25.

(24-9)



Reach into the opening, indicated by the arrow in the above illustration, and spread it out so that it looks like one of the spaces between the corners of the handkerchief.

"Now, I'll just gather the handkerchief by the corners and let you hold it as am, Frances."

Give handkerchief to Frances to hold by the four corners, keeping prepared opening toward John.

Get the Egg Bag.

"John, I suppose you still believe in fairies and brownies and all that sort of thing; but you would, no doubt, be surprised anyway if a fairy princess came tripping put of this bag which I have here and tapped you with her magic wand. I guess we'd all be surprised."

Unfold bag and hold it with the OPENING DOWNWARD so that the egg will not fall out through trick opening and into the bag. Be sure to have double side of bag containing the egg nearest you.



FIG. 26

Now turn bag around so that double side comes toward audience, screening egg with right fingers. Reach into each side of bag with thumbs and turn bag inside out.

Figure 26.

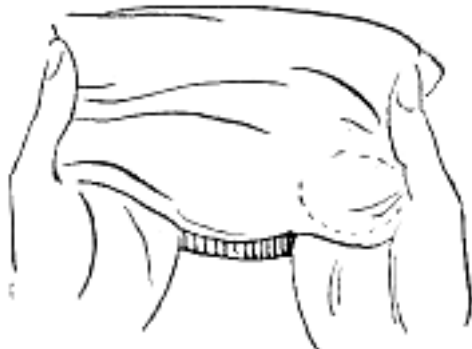


FIG 27

This brings the double side of bag nearest you again with the egg concealed in it against your right palm.

Figure 27.

"Well, there is no need to be surprised for there is nothing inside the bag."

Turn bag inside out and back to outside again quickly several times. The trick opening in the double side of bag is not visible to audience. As you turn bag, it is stretched a little and there are folds in it so that the opening cannot be seen.

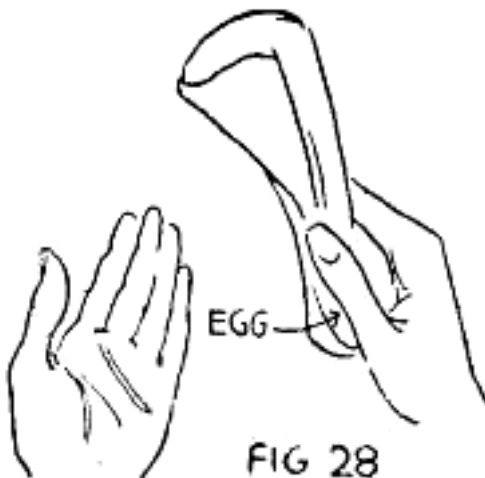


FIG 28

Now with trick opening again on inside, roll up bag. Hold egg in right hand and strike left hand several times with other end of bag. This is to prove that bag is empty.

Figure 28.

Unfold bag again, keeping double side nearest you. Hold bag now with opening at top as you would naturally. The egg automatically drops down through trick opening into the bag. Fold the bag again.

"John, if you hold the egg in your left hand, I will give you this bag to hold in your right. Then you will be doing it RIGHT."



FIG. 29

Give folded bag to boy to hold at the top. He cannot feel egg inside as this is at the bottom.

Figure 29.

"By the way, John, were you ever a magician?"

He will, of course, shake his head or say, "No."

"You were. That's fine. Then I can let you do this trick instead of me. Frances, you don't mind if John does the trick, do you? Oh, you'll help him? Well, that's better yet. All right, John, bring the egg over and drop it into the handkerchief. First hold it up and show it to the audience and then drop it into the handkerchief."

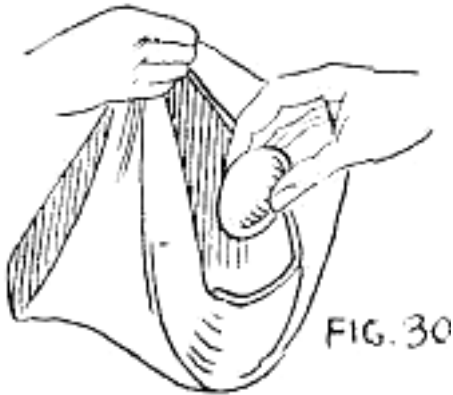


FIG. 30

Have John drop egg into opening you have prepared between the two handkerchiefs. You can open it wider as he goes to drop egg in so that he will have no difficulty in getting it into the right place.

Figure 30.

To all appearances he has dropped egg into center of handkerchief, but in reality he dropped it between the two handkerchiefs through the fake opening.

"Yes, you dropped it all right. I can feel it. Frances, do you feel the egg resting so cozily here in the bottom of the handkerchief?"

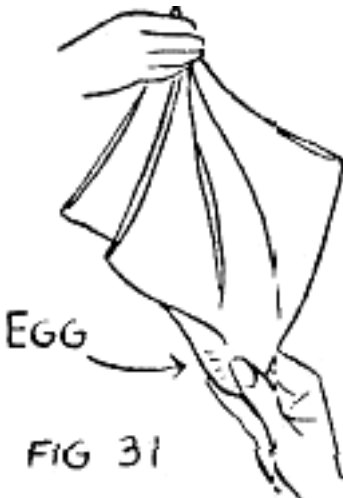


FIG 31

Let her feel the egg through the handkerchief.

Figure 31.

Reach over and take the MARKED corner of handkerchief between your left thumb and forefinger and take the next corner with your right thumb and forefinger. Be careful that you take the right corner in your right hand to keep opening of handkerchiefs at the top. Do not remove handkerchief from Frances' hands yet.

"Now, Frances, if you will take the egg."



EGG INSIDE OF HANDKERCHIEF

FIG. 32

Now take the handkerchief. Let the other two corners of handkerchief, which you do not hold, fall down so that handkerchief is spread out between your hands before the audience. The egg falls to the bottom between the two handkerchiefs. It seems that the egg has vanished into the air. Show both sides of handkerchief.

Figure 32.

"That's strange! I thought we had an egg."

Crumple up handkerchief in right hand and place it in coat pocket or some other convenient place where egg will not be visible.

"Oh, I forgot that was a magic handkerchief and that the egg, not being an Easter egg, would not stay in the magic handkerchief. John, give me that bag."

Take bag from John and open it. Be careful to show hands empty. Hold bag with opening upward by your finger tips.

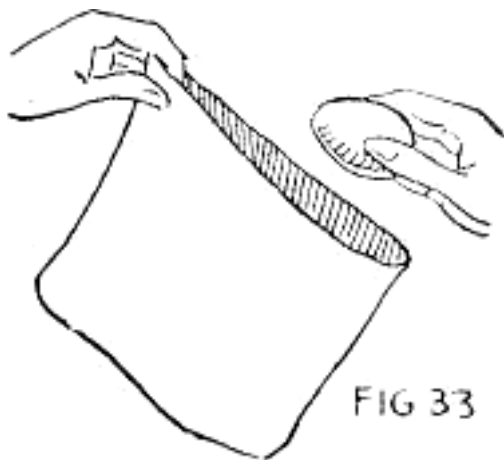
"Now, John, reach inside."

John reaches in and takes out the egg.

Then you take the egg in your right hand.

Figure 33.

"There's the egg! John, I congratulate you. I forgot you were a master magician and so you played a trick on Frances and me. Now, Frances, suppose I show John a trick. Watch me closely. Here is a bag and here is an egg."

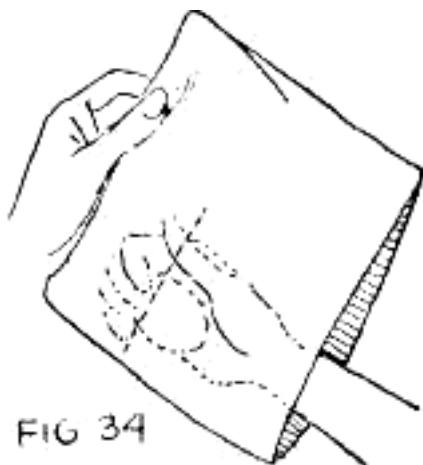


Bag is in left hand and egg in right hand. Show both freely.

"I will place the egg inside of the bag."

Hold bag in left hand as shown in Figure 34. Double side is nearest you. With right hand place the egg inside the bag and into the trick opening.

Turn open end of bag downward, letting the egg fall between the partition and outside of bag just opposite the trick opening.



Position of bag and egg is shown in Figure 34A.

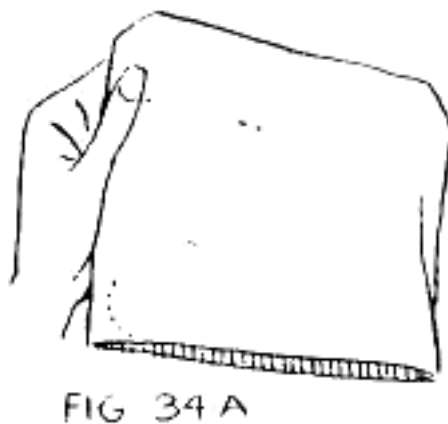
"And when I say, 'Go,' the egg will disappear. Are you ready? One, two, three -- Go!"

Remove right hand quickly from bag, keeping back of hand to audience. Shake bag up and down, keeping your eyes on it. Then suddenly reach into right trouser's pocket with right hand and quickly withdraw hand.

The effect you are trying to create to the audience is that you took the egg from the bag and placed it in your pocket and that you tried to do this unobserved.

"See, it is gone."

Turn bag inside out and back again several times.



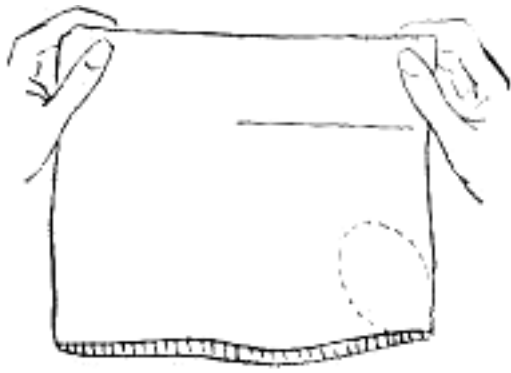


FIG. 35

Now turn bag wrong side out again with the trick opening toward you. Egg is, of course, on right side of bag at the top of it, which is held downward.

Figure 35.

(24-12)

THUMB COVERS OPENING

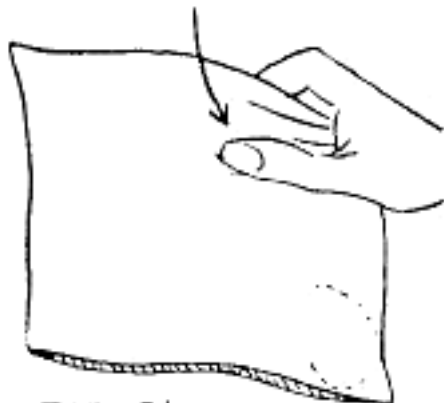


FIG. 36

Cover trick opening with thumb, holding the bag by the right corner in the right hand. Turn this side of bag to audience and back again toward yourself.

Figure 36.

Of course, there is excitement in the audience for they KNOW that you placed egg in your pocket. You are working for this excitement and the comedy touch and you pretend not to notice what the audience is saying.

"There, I have turned the bag inside out and outside in to show you that the egg has disappeared."

The audience will be saying, "It's in your pocket." You assume great surprise and say,

"In my pocket? No, no, there is nothing in my pocket."

Turn your left trouser's pocket out and replace. Audience says, "No, the other pocket."

"Oh, yes, the other pocket ..."

Show your vest pocket. As the audience insists that you have the egg in your other pocket, show your coat pockets.

Finally, pretend that you at last understand what they mean.

"Oh, you mean in my trouser's pocket? Oh, no, there is nothing there. Now, we'll continue."

As you have not shown your right trouser's pocket, the audience is convinced that the egg is there. The excitement grows greater than ever.

Now turn your right trouser's pocket inside out. It is empty, of course.

THE AUDIENCE IS AMAZED.

"Well, John, the egg flew away. This egg, however, came from a homing pigeon and it takes after the pigeon. If you take it away, it flies back again, invisibly, because it travels so fast. The egg is now back in the bag."

Peep inside of bag, but do not let anyone else look inside. By this time, have bag right end up. The egg, of course, automatically drops into the bag through the trick opening.

"There it is, back in the bag."

Drop hand with bag to your side for a moment. Pretend that you are not going to show egg to audience. Of course, they are not going to take your word that the egg is in the bag. But you continue in an unconcerned manner.

"Now, for our next trick, Frances."

Excitement in audience has started again for they are not satisfied that the egg is in the bag. In answer to their remarks, you say,

"Oh, pardon me—pardon me. Frances, reach into the bag."

Frances brings the egg out.

"There's the egg. Perhaps, John, you would like to have me explain this to you in a clear, concise manner. First of all, you get an egg and a little cloth bag this size. Then you put the egg into the bag."

Place the egg in the bag with your right hand.

"Having put the egg into the bag, you take it out again. You must keep your hand closed over the egg and the back of your hand toward the audience so that they cannot see it, and slip the egg into your pocket."

Take egg from bag with fingers curled over the egg to hold it easily. Show how egg is held and slip hand into right trouser's pocket.

"But you do not leave it in the pocket. You take it out again and slip it underneath your arm next to your coat and keep it there with the pressure of your arm."

Take egg from pocket again and place it up under your left arm so that you can hold it easily in place by slight pressure of the arm.

Figure 37.

Hold egg with right hand and raise left arm a little to show that egg is under arm pit.

"As the pocket is empty, it is easy to show it empty. And as there is nothing in the bag, it certainly isn't difficult to show it empty. Now when you want the egg again, just reach up under your left arm with your right hand, let the egg fall into your hand, and then reach into the bag and bring out the egg."

Reach up under arm and take egg in right hand, curling your fingers over it. Reach into bag with back of hand to audience and bring out the egg at your thumb and finger tips.

"I is just an easy trick after all, isn't it? I'll show you once more how to do it, in case you didn't follow it."

Place egg in bag again with right hand just as you did before, getting egg into trick opening. Figure 34. Turn opening of bag downward so that egg falls to top of bag. Figure 34A.

"Place the egg in the bag. Then take egg out again, keeping back of hand to audience."



Pretend to take egg out, back of hand to audience, but actually leave it in the secret pocket of the bag. Place hand in pocket as though putting egg there.

"Then you take egg out of pocket again and place it up under your arm."

Take hand from pocket as though holding egg and pretend to place egg under left arm pit. Hold left arm pressed awkwardly against you as though you had an egg under it.

"Then turn the bag inside out and, of course, there is no egg in it."

Turn bag inside out several times. The egg, of course, is in it, but the audience is not aware of this. They think your explanation is bona fide.

With bag turned right side out again, hold it in left hand, opening downward.

"Of course, the egg under the arm is perfectly safe unless you should accidentally lift up your arm."

Raise up your arm as you say this to show that egg is gone. Turn your left side to audience to convince them that egg is actually gone.

"And then, you see, you might not have any egg. In that case, you can wave your arms freely and show your pockets empty."

Wave your arms about and turn your right trouser's pocket out to show it empty.

"Of course, the bag is empty."

Turn bag inside out and back again. When it is inside out, egg is in position shown in Figure 27 against your right palm. Then in turning bag back again, hold egg in place with right thumb.

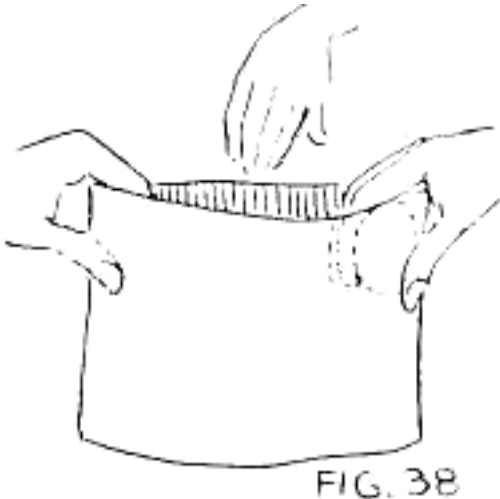


FIG. 38

Now shift your hands so that your fingers are inside of the top opening instead of your thumbs. Bag is now turned with the opening upward and egg is held at top by right hand.

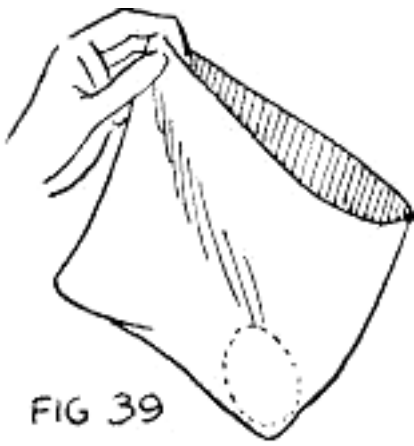
Figure 38.

"The egg is not in my hands, not in my pocket, not under my arms, not in the bag, so it must be somewhere. By the way, John, did you feel inside the bag? But first, hold my right wrist with your left hand and, Frances, you hold my left wrist so that an egg cannot jump down out of either of my sleeves."

John and Frances take hold of your wrists.

"Now, reach in, John, and feel around."

John, of course, finds nothing in the bag. When he has taken hand from bag, release egg from your right hand, and it will fall into right corner of bag through trick opening.



Remove right hand from bag and hold it above bag, showing it empty with fingers spread wide apart. Hold bag in left hand in position shown in Figure 39.

"You felt all over the bag, didn't you? In this corner and that corner?"

Reach into bag with right hand and feel around inside. Then take out hand with the egg. Hold egg up so that all can see.

"Really, I think there is some trick to this because there is the egg."

Have children release grip on your wrists. Bag is in your left hand. Curl your right hand about egg and then grasp bag with right hand.

Turn left side to audience and look at John. Talk to John to MISDIRECT his attention as you lift right hand from bag to right coat pocket and drop egg into it.

"It all goes to show, John, that you cannot watch too closely."

Point to him with the bag. After you have deposited egg in pocket, withdraw right hand immediately and replace it on the bag.

"Now, here is this simple little bag."

Show bag in left hand.

"And this simple little egg."

Look at right hand, pretending you think egg is there. Show right hand empty with much surprise on your part.

"I thought I had the egg. John, did you take it? That's strange."

Look at both sides of bag, without turning it inside out. Then crumple it up in left hand and place it in left coat pocket.

"John, have you the egg in your pocket?"

Step close to John and feel his right coat pocket with your left hand. Then feel his arm and his back.

Figure 40.

As you lean forward close to John, your coat opens a little. Reach up under left side of your coat with right hand. Grasp Body Load pinned to your vest. Pull the thread loop and break it, getting bundle into right hand.

(24-16)





Figure 41.

Bring your left hand to John's shoulder. Grasp the edge of his right lapel and pull it toward you, thus opening the right side of his coat. His coat acts as a screen when you are close to him so that you can place the bundle in your right hand quickly up under the right side of his coat.



Figure 42.

Push bundle well up under coat, then release hold on John's lapel with your left hand. Now place your left hand up under his coat and push the bundle over his shoulders to his back. As you do this, turn John around a little so that when bundle gets into position on his back, the audience will not see the bulge under his coat. Grasp John's left arm with your right hand.

When bundle is in position, bring left hand down again and grasp John's right lapel. Pretend to continue to search him with your eyes. Then turn John around so that audience can see bulge on his back.



Figure 43.

"Pardon me, John, but what is this slight bulge in the back of your coat here?"

With your left hand reach up under John's coat again and grasp the bundle. Also reach down through the top of his coat in back with your right hand. Unpin the bundle quickly and pull out the stocking with your right hand.



Figure 44.

"It must be some of your wearing apparel."

Hold stocking up for John to see. Reach into coat again from the top. Assist your right hand with left hand on outside of coat. Remove the baby stockings.

"Really, John, you have quite a collection."

Show garments to John. Open up every article so that audience can see them all plainly.

Reach in again and pull the rest of the baby clothes out one at a time, showing each one as you remove it.

"But never mind, John, it always pays to do your Christmas shopping early."

Dismiss the children, thanking them for helping you.

NOTE:

Many funny articles can be pulled from a boy's coat. Even a baby bottle half filled with milk could be placed inside of the load.

Sometimes a pocket is sewed or pinned to left side of vest with an opening at top to hold articles.

In transferring bundle from yourself to boy, the MISDIRECTION IS VERY IMPORTANT. Your eyes and left hand must distract the attention from your right hand.

Use great care in putting the load up the boy's back. Be sure that it is far enough up so that it does not drop out accidentally. Your left hand can aid you in adjusting it.

Practice this Body Loading well. Skill in doing it will be very useful to you later on when you learn other productions.

A handwritten signature in cursive script that reads "Harlan Tarbell". The signature is fluid and elegant, with a large, sweeping flourish over the "l" in "Tarbell".

TARBELL SYSTEM, INCORPORATED, Chicago.

* * * * *

LESSON 25

HOW TO VANISH AND PRODUCE A LIVE RABBIT. Imagine it! So soon you are ready to learn this wonderful magical effect --this baffling effect which has so often amazed you! The different methods you learn for vanishing and producing other small animals such as doves, guinea pigs, chickens, etc., will prove most interesting and invaluable to you as a Magician. This lesson means a great big step forward for you in Magic!

(24-18)

LESSON 25

You have made wonderful progress with your Magic! Here, you are on your twenty-fifth lesson already. I want you to stop at this point and think back on how much you have learned.

First, and above all, you have learned much of the Science of Magic -- that is, the Psychology of Magic, Showmanship, the PRINCIPLES of Magic, of Sleight of Hand. Secondly, more than 60 effects of great variety have been revealed and taught to you so that they are now YOURS.

You realize by now that this is no mere "bag of tricks" you are getting in this Course. I think this is a good time for you to go back again and reread the section on Magic as a Science in Lesson 1. Then thoroughly review the many principles taught you, using the outlines in Lessons 4 and 13. This review of principles every once in a while is absolutely essential to your success. Each time you review, the principles establish themselves more firmly in your mind and become a part of you. And, of course, the more automatic the working of the principles becomes, the better is your presentation of the effects.

Review

Lessons 13 to 24

I give you here a brief outline to aid you in continuing your review from Lesson 13 to Lesson 24 inclusive.

This time that you spend in reviewing will pay big dividends. You can easily see for yourself how much your performing improves after having gone over your lessons at several different times.

Lesson 13 is an interesting Card Lesson and teaches you the important Principle --

The Regular Pass

Lesson 14 gives you novel effects with cards in combination with fruit. The Principles taught are:

The Force

The Jog

The Thumb Palm

Mechanical Arrangements explained:

Handkerchief Card Concealment

Double Envelope

False Pip

Cloth Changing Bag

Lesson 15 -- Effects from the repertoires of two preeminent Magicians, T. Nelson Downs and Percy Abbott of Australia.

Important Principles of Palming and Shifts:

Right Angle Slip Up Palm

Oblique Slip Up Palm

Right Angle Kick-In Palm

Oblique Slip Up Palm Shift

Index Finger Shift

Thumb-Little Finger Shift

Lesson 16 -- More of the Magic of Cards with effects from another Great Magician, Ed. Reno, putting into use Principles you have learned.

Lesson 17 -- Cardini, the wizard of England, reveals some of his famous experiments in this lesson.

Principles:

Edge of Coat Concealment

Back Hand Palm and Flash Production

Card Changing in Glass

Card from Empty Examined Envelope

Lesson 18 -- The remarkable Principles of Rising Cards, known and used by the great men in Magic. Cardini's Rising Card experiment also taught to you.

Lesson 19 -- Original Rising Card Effects from my own repertoire. Beginning of your instruction in constructive work.

Lesson 20 -- A most valuable lesson discussing important points to help you become a finished artist in Magic:

How to Please Your Audience

Keeping Up With the Times

Making an Impression

Maintaining a Healthy Attitude Toward Magic

In addition, you learn two interesting effects, one with a wand and one with bands, and

Arrangement of Programs

Lesson 21 -- Thorough analysis of the Principles of Sleight of Hand with Coins:

Thirteen Different Palming Principles

Eight Coin Holds

Twelve Manipulative Methods of Vanishing Coins

How to Dispose of Coins

Change Over Methods

Lesson 22 -- Coin Classics, involving the use of Sleight of Hand Principles you have learned.

Lesson 23 -- More interesting Coin Effects.

Study your Patter carefully to make your experiments more effective.

Lesson 24 -- Tricks with Eggs, teaching you the handling of eggs. Good opportunity for Comedy Magic here.

Also, you learn how to make my most efficient Egg Bag.

I hope you are giving the best that is in you to Magic so that you may join the ranks of the successful. Do you realize that the famous magicians of the world today are using these same effects, which you learn, on the stage and are making their reputations and success and money with them? You are being equipped to go out and make your start toward fame and fortune. And you have the tremendous advantage of having this Scientific foundation in Magic.

The great Magicians today had to start at the very bottom and strike out blindly to grasp what they could of Magic and hope for the best. But you have done away with years of hardship and failure. You can start ten years ahead of the point where these Magicians started. You can go out with CONFIDENCE and make a success.

* * * * *

LESSON 25

This is a wonderful lesson. You learn new and interesting productions of live rabbits or other small animals. You also learn construction of your apparatus. A knowledge of how to build your own apparatus is absolutely essential to your success, and here you begin with the building of valuable production boxes.

I AM SAVING YOU MONEY

Have you ever stopped to think how many, many years of experience and experiment and how many thousands of dollars it has taken to bring the effects in this Course to you? Painstaking analysis and constant simplifying have been done. And now YOU can get the benefits of it with little effort and little money. Big effects which required expensive and massive apparatus you can now perform with ease. I teach you how to master the effects easily and quickly, and I teach you how to build your apparatus at trifling expense.

Professional Magicians of years of experience tell me time and again: "It is marvelous the way you teach effects with such a small cost of production. There is nothing in the whole course that a man cannot build for himself or have built for just a small amount."

It is small wonder that the world's foremost Magicians say this Course would be cheap at \$1,000. Many of them spend fabulous sums on one effect alone.

(25-3)

Only recently, Thurston wrote me that he had spent about \$10, 000 trying to simplify and perfect a certain illusion. Leon told me that he spent \$1, 000 for the secret of one effect which he is using in his vaudeville acts -- a secret so simple that a schoolboy should know it, yet one which is baffling the finest vaudeville audiences in the country.

Percy Abbott, famous Australian Magician, said to me one day: "It takes a man of experience really to value what you are teaching. If I were to start all over again in Magic as I did years ago and someone were to offer me \$10, 000 or your Course in Magic, I would take the Course. Knowing what I do today, I say that your Course means a saving of TEN YEARS in working toward success."

So remember -- the analysis and simplification of effects which I teach you is SAVING YOU MONEY. None of the value of the effects is lost. In fact, some of the experiments are improved -- yet the construction of the paraphernalia is so simple that you can do it yourself for a very small expenditure.

In today's lesson I teach you the construction of production vanishes, which you can do at home. It is not a bit unusual for Magicians to spend a hundred dollars or more for production vanishes of this kind.

* * * * *

EFFECTS WITH RABBITS

The Production and Vanishing of animals is an important part of Magic. The rabbit seems to be the most popular animal for this work. He is easy to handle and the audience always likes to see a rabbit, especially if there are children among the spectators.

In this lesson I teach you how to produce and vanish a rabbit, using apparatus which is simple to make. All you need is a hammer and saw, a paint brush, and some wood. Despite the simplicity of the apparatus, the effects are most mystifying.

Once you learn the principle of construction of the apparatus, you can use it in any size or shape for production and vanishing of other animals. A guinea pig, a couple of doves, a chicken, a duck, a white mouse -- or even three or four rabbits -- may be produced and vanished by building the apparatus in accordance with the requirements. Various other articles may be produced and vanished with the same apparatus -- such as an elaborate silk production with various colored Chinese or Japanese silks.

* * * * *

THE "MODERN" RABBIT BOX PRODUCTION

This effect is valuable for the production and vanishing of a rabbit. It has also possibilities for the transforming of articles -- such as changing a white rabbit into a black one,

etc. A little ingenuity on your part may produce some excellent effects.

This production works well in pantomime. If you have music to accompany you, you can enhance the value of the effect.

However, the experiment permits of good patter. It may be presented, for instance, as a Chinese experiment with a description of the way in which some old Chinese conjurer performed it. It may be performed as Pandora's Box with a production of what she found when she opened the lid of the box. Or it may be presented as Milady's Hope Chest in this way: Ask some lady to make a wish as to what she would like to have appear in the hope chest. Make the request general, merely looking in a certain direction. Several people will probably make wishes, and then will think you meant someone else. Then you can say, "Rather a funny wish - a rabbit's foot; and here you are, four of them," and produce the rabbit from the box. You can get a good comedy effect this way: Say that you are going to build a man's Hope Chest and whatever a man wishes will come into it. Motion to some bald-headed man and say, "Ah, the gentleman wishes for a little hair (hare). Here you are, sir - a little hare." Then produce the rabbit.

Should you care to produce a chicken instead of a rabbit, name the effect, "The Darkey's Dream." The production of a chicken is self-explanatory. If performed before a juvenile audience, the effect may be called, "The Easter Box." Produce some colored Easter eggs, and then finish by producing the rabbit that laid them. Any other original idea which appeals to you can be worked up with this apparatus. Do some original thinking and you will be surprised and pleased at your own ability to create effects on the principles I give you.

The rabbit production which I teach you here is presented as a Chinese story. This makes an excellent stage presentation.

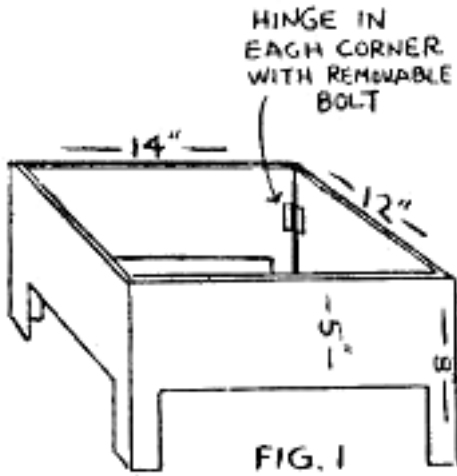
EFFECT:

Performer constructs a small table on the floor or on another table. Then he shows an empty box with no top or bottom. This he places on the table. Next he shows a lid on both sides and places it on the box. In spite of the fact that trickery seems impossible, magician now raises the lid and takes a live, squirming rabbit from the box.

PARAPHERNALIA:

- 1 -- A special small table with fake removable top.
- 2 -- A box without top or bottom.
- 3 -- A lid to fit over box.
- 4 -- A rabbit.
- 5 -- A chair and a table.

HOW TO CONSTRUCT THE APPARATUS:

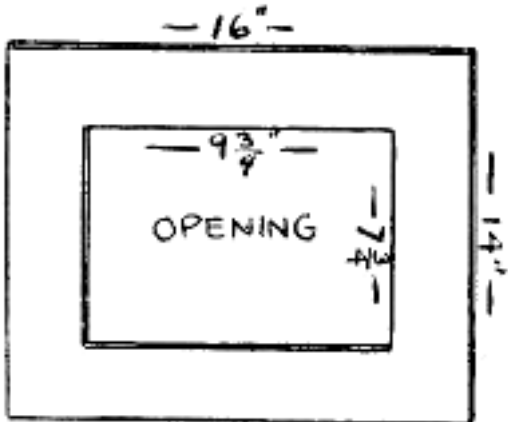


The Base of Table:

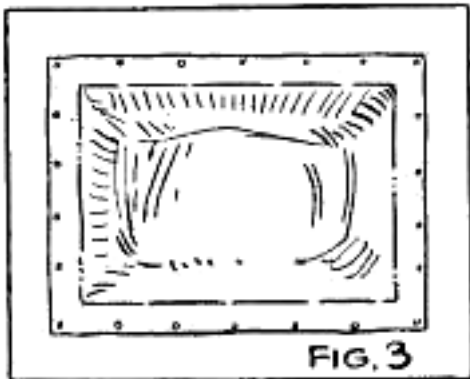
Get four boards about a quarter to three-eighths inch thick -- three-ply wood is good. Cut down two boards to 12 inches, and two to 14 inches to make the box 12 x 14 inches. Now saw the boards down to 8 inches depth and cut them up three inches to make legs as shown in Figure 1. Then fit the boards tightly together and hinge them inside with good, strong hinges in each corner. Hinges should have removable bolts so that they can be removed and box packed flat. Study Figure 1 carefully.

Special Table Top:

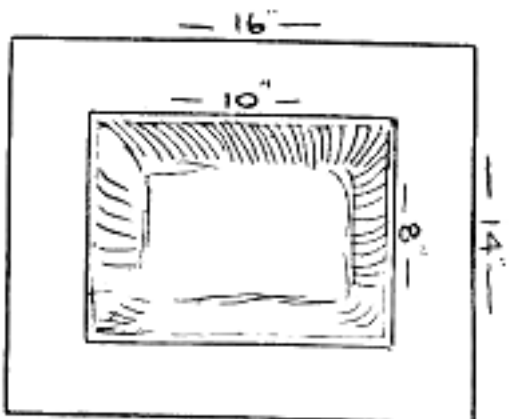
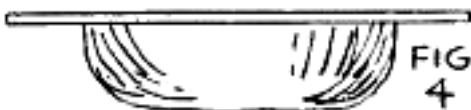
In the table top lies the trick. This must be built to look just like a thin table top and yet faked to conceal a rabbit.



Take another board, 16 inches long x 14 inches wide. Cut a hole in the center, 7 3/4 x 9 3/4 inches. Figure 2 shows you a diagram of the table top with the exact dimensions.



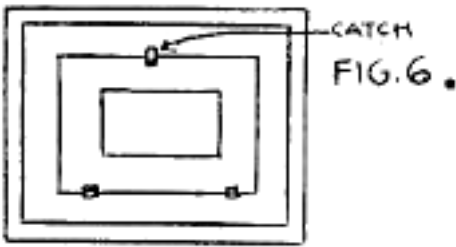
Take a piece of black cloth, large enough to hold a rabbit. Tack it all around the opening of the board to make a bag. Figure 3. Figure 4 shows side view of board with bag in it. This bag should not hang down too low or it will be exposed at bottom of the base of the table.



Now take another thin board, 16 x 14 inches. Cut out the center of this to make an opening 10 x 8 inches. Place this board on top of the board with bag so as to cover tacked edge of cloth. Screw or nail the two boards together. Figure 5.

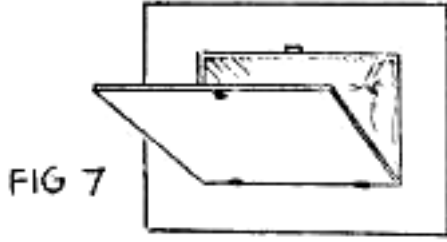
Use thin, three-ply wall or furniture board, as this will not warp. Have each board one solid piece. It is well to take a little pains in constructing this table top, for if you make it well the first time, it will last.

Take a board large enough to fit the opening in the special table top and make a door. Put two hinges on one side and a catch on the other. Have the catch secure and yet one which is easy to open.



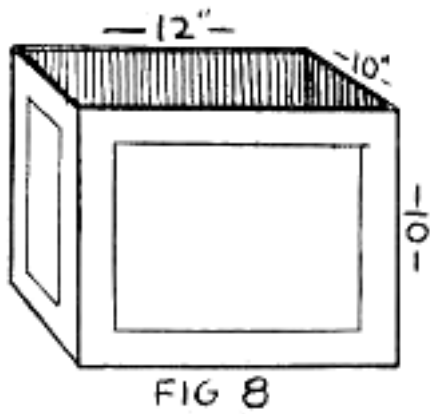
Figures 6 and 7.

IT IS WELL TO PAINT OR LACQUER THIS TABLE AND TOP. Use Chinese red and stripe or decorate it with black. Figure 6 shows how stripes may be painted around the table top. The strip around the edge of the door should be wide enough to camouflage the hinges and catch of the door.



The table top should look like a thin unprepared board with no suggestion of magical properties. Therefore the smaller and less visible the hinges and catch can be made, the better. It is wise to sink the hinges and catch into the wood so that they do not protrude at the top of the table.

The Box:



Make a box of thin boards without a bottom or top. Size: 12 inches long x 10 inches wide x 10 inches deep. Paint and decorate the box with stripes as you did the table and table top.

Figure 8.

Top for Box:

The top for box is also of thin three-ply wood. Make this top 14 1/2 inches long x 12 1/2 inches wide. Paint and decorate it as you did the table top. It is well to establish a certain color harmony between the four pieces of apparatus -- the base of the table, the special table top, the box, and the box top. It is effective to use Chinese characters or decorations on them, although you may decorate them in any manner you choose.

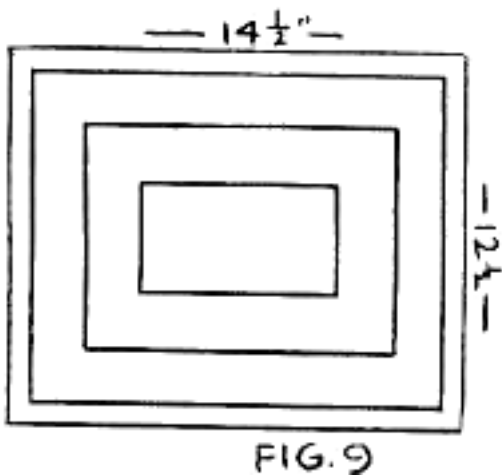


Figure 9.

* * * * *

SECRET AND PATTERN:

To Prepare:

Place rabbit in the bag of the special table top, close down lid, and fix catch. Arrange the four pieces of apparatus on a chair in this manner: Box top against back of chair; Box in front of it on seat of chair; Special table top on the box; Table base on table top. Rabbit, of course, is under the table top inside the box.

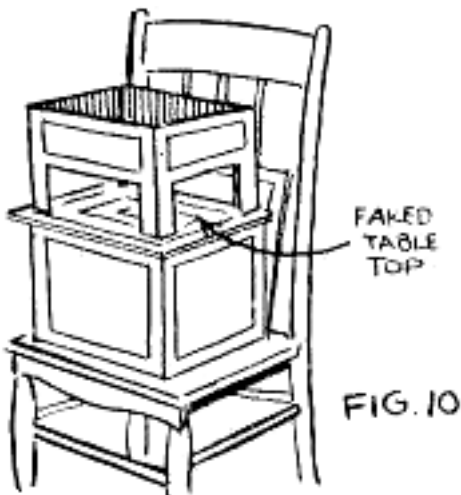
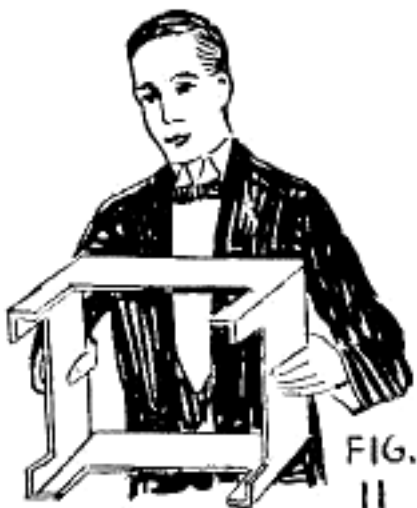


Figure 10.

To Perform:

Come forward and start with your Patter.

"Once upon a time, an old Chinese conjurer told me how he used to make certain wishes come true. 'First of all,' he said, 'make a table. Take a table base with a hole in it.'"



Pick up the table base. Show it to audience, turning it all around and on end so that they can see through it. This is to show that nothing is concealed.

Figure 11.

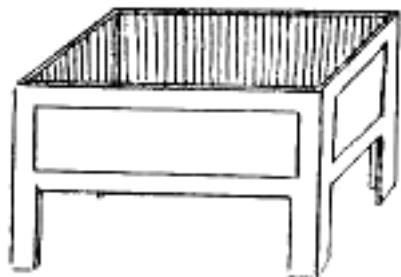


FIG 12

Now place the table base on a table, setting it squarely in front of audience so that they can see it plainly.

Figure 12.

"Then he told me to place table top on this."

Pickup the table top, grasping it by the end farthest away from the audience. This causes the other end to slant downward and thus conceal the rabbit in the bag under it. Place this top on the table base, putting down the side nearest the audience first.



FIG.13

Figures 13 and 14.

(25-7)



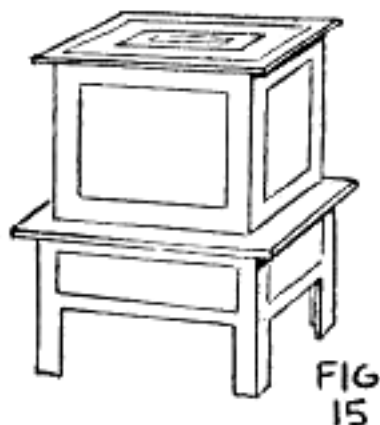
FIG.14

Do this quickly and in a careless manner, as though you just picked up a board and laid it on the table base to make a top. Your MISDIRECTION here is your easy way of handling the special top.

"Now the important part is this magic Chinese Wishing Box."

Pick up the box. Run your right arm through it to show it empty, also hold it up high and move it from side to side so that audience can see through it and is convinced that it is empty.

"This box was built during an early Chinese Dynasty, 935 B. C. – B. C. meaning By Chinaman. By Chee Wu, the grandfather of Ching Poo. In fact, Chee Wu gave me this box himself. 'Now place the box on the table,' said Chee Wu, 'and cover it carefully.'"



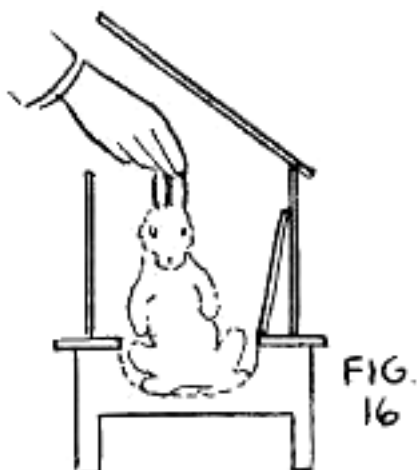
Place the box on the table top. Then pick up box top, show it on all sides, and place it on box.

Figure 15.

"The lid is on. This is the box that makes wishes come true. Will you make a wish, sir?"

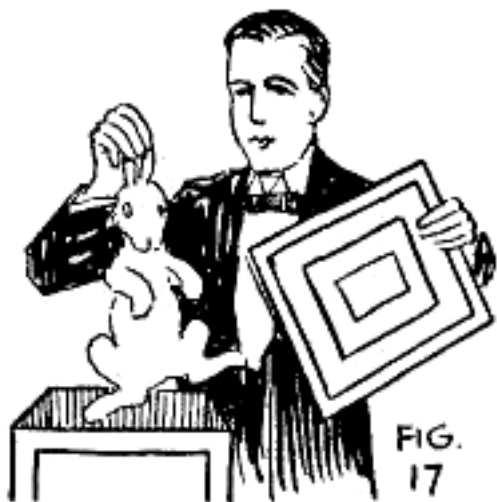
Nod in the direction of someone in the audience, but to no one in particular.

"What a strange wish, sir. The gentleman wishes for a rabbit's foot. No doubt, to keep the evil spirits away."



As you say this, with left hand raise end of lid farthest from audience. With right hand reach into box, open door of table top, grasp rabbit by the ears, and pull him out.

Figure 16.



The rabbit is produced, of course, from under the table top, which is under the box. To the audience, however, it appears that you take the rabbit right out of the box. As you produce rabbit, remove top of box entirely, then show rabbit so that all can see.

Figure 17.

"There you are, sir, not only one rabbit's foot, but four of them."

NOTE:

Should you ever desire to use box for a Color Changing Rabbit Production, work it this way: Have a white rabbit in the bag in table top. Have a black rabbit out in full view. Remove box top and reach into box with left hand. Raise door of special table top. Take the white rabbit out of the bag and drop the black one in. Now Produce the white rabbit. Let the door of the table top fall back into place with the catch securing it. It is well to pad the door with felt to prevent its making a loud noise when falling. Then remove the box and show it empty.

If apparatus is large enough, the two rabbits may be placed in the bag at the beginning. Take the black one out first, then pretend to overhear someone saying that they do not want a black rabbit. Use suitable patter here. Then drop black rabbit back into the bag and produce the white one. In this production, lift up the box and show it empty after each color change.

Work quickly! Fumbling ruins your effect. To the audience a second seems as long as a minute if your performance is not snappy.

THE "SUCKER" RABBIT BOX VANISH

"Sucker" tricks in Magic are those in which the performer apparently "gives away" the trick. This is done in an exaggerated manner, and the audience is sure that they know how to do it, much to the performer's discomfiture. The magician tries to cover up matters, only to make them worse, until at the finish he proves that the audience is wrong in their conclusions and that he has fooled them after all. You have an example of the "sucker" effect in the last lesson when you use the Egg Bag and pretend to place an egg in your trouser's pocket. These effects are always very popular in Magic.

This "Sucker" Rabbit Vanish is amazing. Juvenile audiences almost go into a riot over it.

EFFECT:

Performer constructs a box with a lid on it. He takes a live rabbit and drops him into the box. Then he makes a magic circle over the box with his hand, removes the lid, and shows the box empty. But suddenly the audience awakes to the fact that there is a false partition in the box and that the rabbit is under that. Magician appears to be embarrassed. After much by-play, he finally raises the partition and opens up the bottom of the box to prove conclusively that the rabbit has vanished.

PARAPHERNALIA:

- 1 -- Special Top for Box.
- 2 -- Special Box.
- 3 -- Rabbit.

HOW TO CONSTRUCT THE APPARATUS:

Special Top:

Follow the directions given you for building the Special Table Top in preceding effect. This special top is constructed in the same way. Size: 14 1/2 inches long x 13 1/2 inches wide. Door size: 8 x 10 inches, with hinges and catch as in Special Table Top.

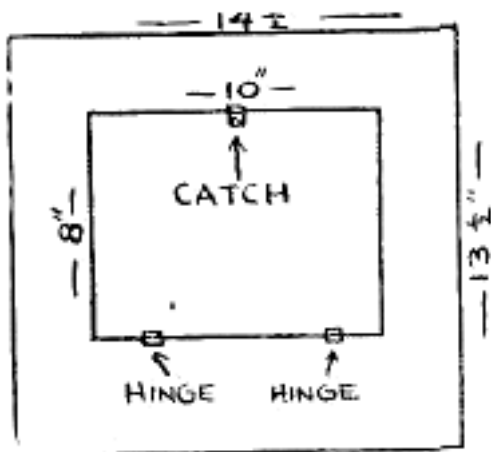


FIG. 18

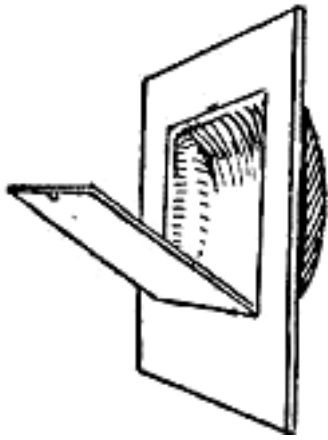


FIG.
19

Figure 18.

Figure 19 shows bag in this Special Top with door open. As you see, it looks just like the special table top.

(25-9)

Special Rabbit Box:

Make this box of rather thin wood. Take two boards, each 6 x 10 inches. Place two of the 10-inch sides together and secure them by some kind of catch which can be opened. This forms the bottom of the box, making it 10 x 12 inches. When the box is completed, these two boards act as doors. Now take two boards 12 inches long x 6 inches wide and two others 10 inches long x 6 inches wide. These form the sides of your box. Hinge them all to the bottom, fitting them tight together. Now take another board about 9 1/2 inches x 6 inches. Place this inside the box with a 9 1/2-inch side against a 10-inch end of the box. Hinge this about one inch from the top of the box. Let the other end fall to the bottom of the box and put a small knob on it.

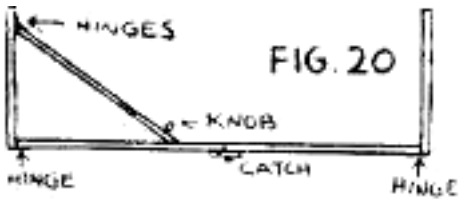


Figure 20 shows a cross section of the box. Notice the catch in the bottom, the hinges on the sides, and the little partition with the hinges and knob inside the box.

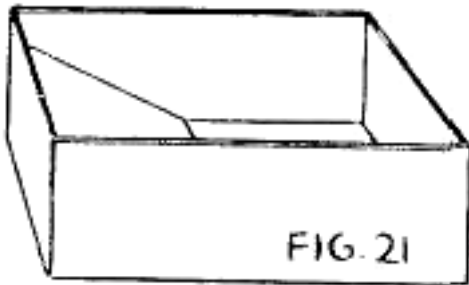


Figure 21 shows the box as it looks when completed.

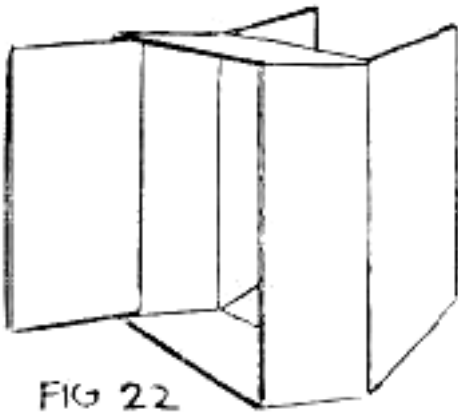


Figure 22 shows the box opened. The catch on the bottom is opened and the two sections open out like doors. The partition is opened outward also with the aid of the knob on it. The audience believes that the rabbit is concealed under this partition.

SECRET AND PATTERN:

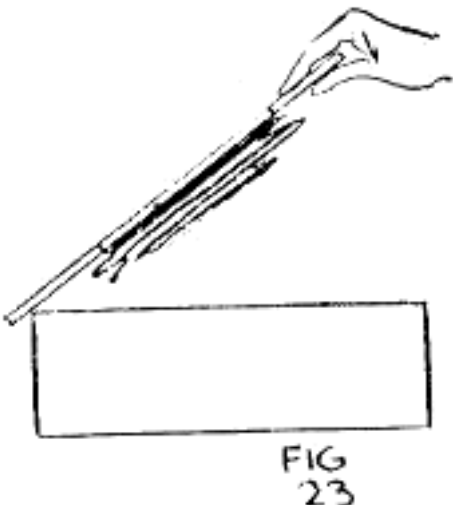
To prepare:

Have the Special Top lying on the table with the bag underneath, of course. The bag collapses and the top lies flat on the table. Have the Box and Rabbit on table nearby.

To perform:

Pick up the Rabbit.

"This is quite an extraordinary rabbit. He is an Easter rabbit and lives in Easter-Egg-Land. It is only by special consent that he has come to visit us at this time of the year. I had to assure him that if he would come to visit us I would get him home all right."



Pick up Special Top by rear edge to conceal bag underneath. Place it on Box, putting front edge down first to screen bag.

Figure 23.

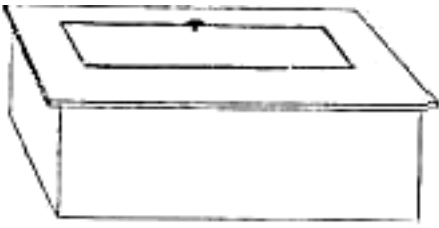


FIG.
24

Figure 24 shows box as it appears to audience. To them the lid is just an ordinary board covering the box.

"This is a rabbit house that I had made for Bunny on his official visit. It is here that he lays Easter eggs."

Open door in the Special Top. Hold rabbit up high for a moment, then place him inside. Rabbit apparently goes into the box, but really goes only into the bag.

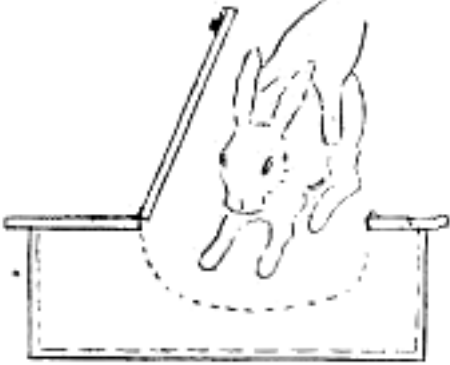


FIG. 25

Figure 25.

(25-10)

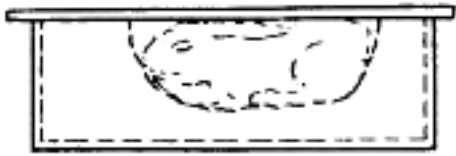


FIG. 26

Get the rabbit well into the bag. Close door in the Special Top and spring the catch. Figure 26 is a cross section of the

box, showing the rabbit in the bag.

Talk to the rabbit inside by bringing your head down near box.

"Are you there all right?"

Pretend the rabbit is answering you. Talk in a subdued ventriloquial voice when answering yourself. Say, "Yes, I'm here all right." Then to audience:

"See, he says that he's all right. What color eggs would you like to have him lay? Blue? Bunny, Bunny, the little girl says she wishes you would lay some blue Easter eggs."

Place ear near box as though listening for a reply.

"Did you hear him say anything? That's funny."

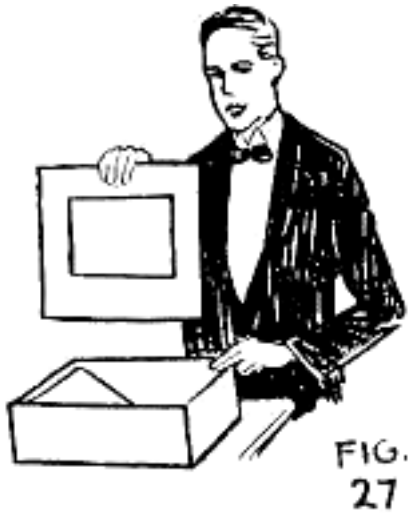


FIG. 27

Remove top of box. Hold bag side away from audience, of course. Keep eyes on box. Place top on a chair nearby or give it to an assistant. Do this quickly as though you are eager to go on and examine the box.

Figure 27.

"Why, he's gone."

Pick up box as though it were rather heavy because of the rabbit under the partition. Hold top of box out toward audience. With right hand hold partition down inside box.

Figure 28.

"The little girl wanted blue eggs, and I guess he just 'blue' away."

Move right hand farther down on partition. Lift it up a little and then replace as though rabbit were trying to push partition up.

About this time the "show" starts with the youngsters. They think that the rabbit has not vanished at all but is under the slanting door in the box.

"We are all satisfied that the rabbit has vanished."

The children are not satisfied, however, and clamor to see under the door.

"Oh, underneath – Oh, no, the rabbit isn't underneath."

Show bottom of box. As the commotion grows, show various parts of the box, but not under the partition. Finally say:

"Oh, under here. There is nothing there. THAT IS JUST THE FLAT BOTTOM OF THE BOX. So now, we're all satisfied that he has gone."



FIG 28

Pretend that you are going to put box away. Finally, when the excitement is at a high pitch, say:

"Oh, I forgot I had a special bedroom built for the rabbit, and you think he is in there."

Open up the slanting door, then release catch at bottom of box, allowing bottom doors to open out.

"He's nowhere around here. He's back in his home in Easter-Egg-Land."

* * * * *

NOTE:

This method of working is presented for use when there are quite a number of children in the audience. It may also be presented as a straight vanish in pantomime style without using Patter at all. This method takes only a few moments.

After you have disposed of top when doing it in pantomime, pretend to hear someone say that rabbit is under slanting door. Shake your head, raise door, and open bottom sections to show box empty.

* * * * *

MILADY'S HAT BOX RABBIT VANISH

The effect can be performed with a cardboard box. In spite of the simplicity of the apparatus, it is easy to produce a rabbit, and the production is very effective.

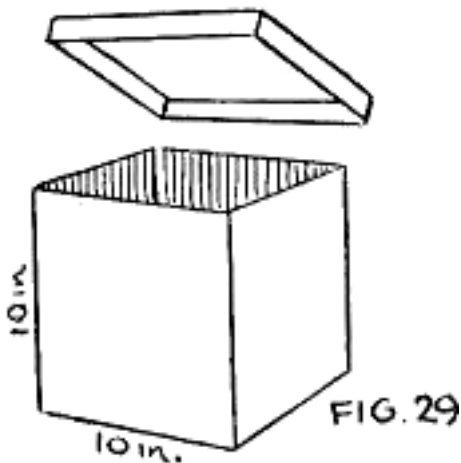
EFFECT:

A cardboard hat box is shown empty. The top is shown on both sides and removed, then rest of box is examined. Top is then replaced. In an instant, Magician opens box again and produces a rabbit from it.

PARAPHERNALIA:

- 1 -- A heavy cardboard box with lid.
- 2 -- A black cloth bag to hold rabbit.
- 3 -- A small rabbit.

HOW TO CONSTRUCT THE APPARATUS:



The Hat Box:

Use a heavy cardboard box, 10 or 12 inches square, with a removable lid.

Figure 29.

FOR STAGE USE OR CLUB SHOWS it is well to make a box of thin three-ply wood. Paint the outside to resemble a hat box, making it white and striping it with blue, green, or red, or cover it with bright red satin for a pretty effect. Line with green. If you desire, you may make the bottom in two sections hinged to the sides and with a catch so that it can be opened to permit spectators to look through box.

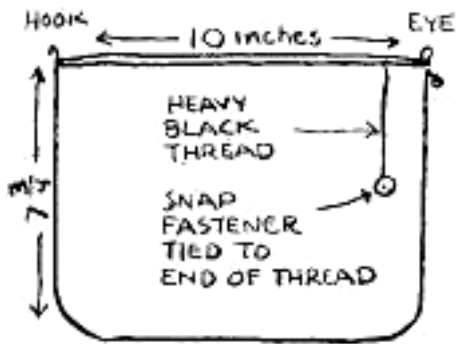


FIG. 30

The Rabbit Bag:

This should be made of soft black cloth. Fold over a piece of cloth to make the bag 10 x 7 3/4 inches. Round the bottom corners and stitch around three sides of the bag. Turn the top in to make a hem and run a black draw string through it, knotting the ends. At one end of top sew a hook and at the other an eye as shown in illustration. Near end of draw string at top, sew a heavy black linen thread about 2 1/4 inches long. To the end of the thread tie half of a snap fastener. Use a large fastener, size 3-0 or larger.

Study Figure 30 carefully. It gives you a detailed diagram of the construction of the bag.

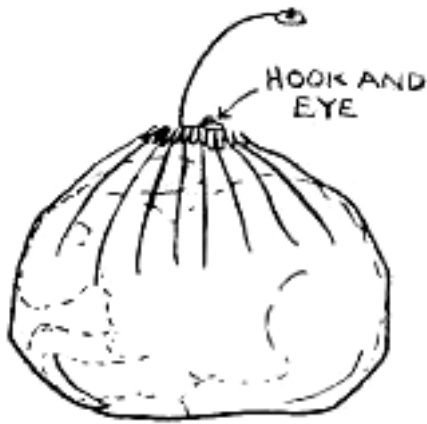


FIG. 31

Figure 31 shows how rabbit is placed inside the bag. Draw the draw string tight at the top and hook the hook and eye to hold it secure. Leave the linen thread with fastener outside.

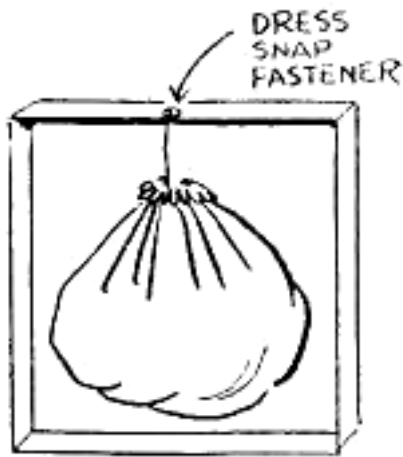


FIG. 32

Top of Box:

Sew the other half of snap fastener to inside of one edge of lid. Now snap the fastener on thread to one on box lid. This permits the bag with the rabbit to hang inside of the lid.

Figure 32.

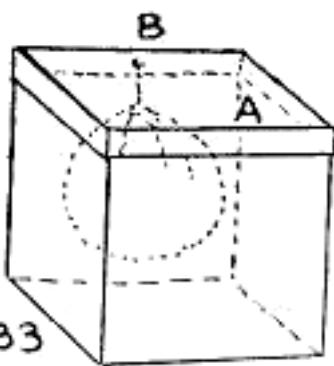


FIG. 33

Place top of box on box. Bag with rabbit hangs down inside attached to lid by thread and fastener.

Figure 33.

MODUS OPERANDI:

To Prepare:

Have box arranged as in Figure 33 with rabbit and bag to rear. Bring it in and place on table or have assistant hold it.

To Perform:

With left hand at back of lid and right hand at front, raise the lid a little and slide it forward on top of box. Curl your left fingers under lid and hold snap fastener to prevent unloosening.

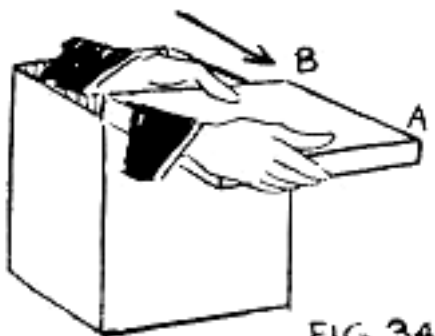
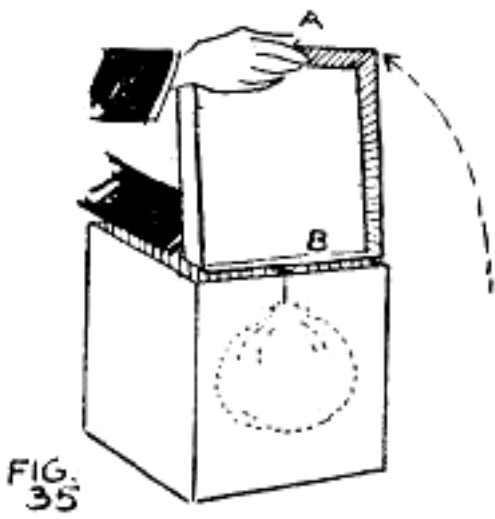


FIG. 34

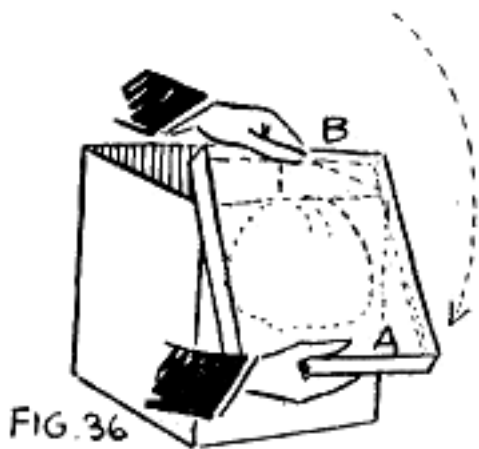
Figure 34.



Raise front part of lid (A) upward to show INSIDE. Audience can see nothing inside of lid. The bag and rabbit hangs inside of box and the snap fastener on edge (B) of lid is not visible.

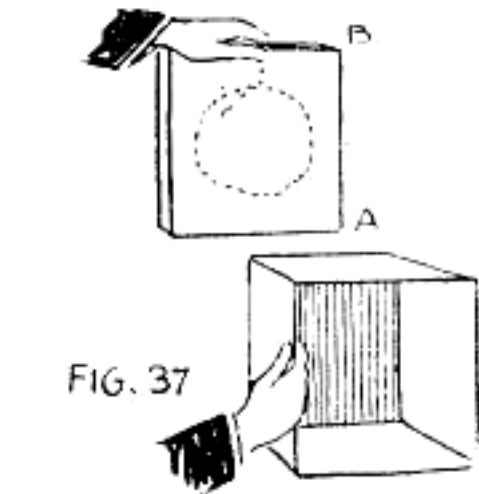
Figure 35.

(25-13)



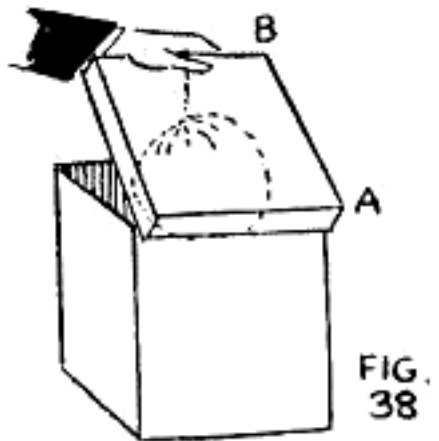
Bring edge (A) down again and let edge (B) come up to show outside of lid to audience.

Figure 36.



Bring lid into vertical position and remove completely from box with left hand. This automatically brings the rabbit bag out of the box to hang down inside and behind the lid. Edges on lid screen it from audience. Hold lid up by edge (B) with left hand and show box empty with right hand.

Figure 37.

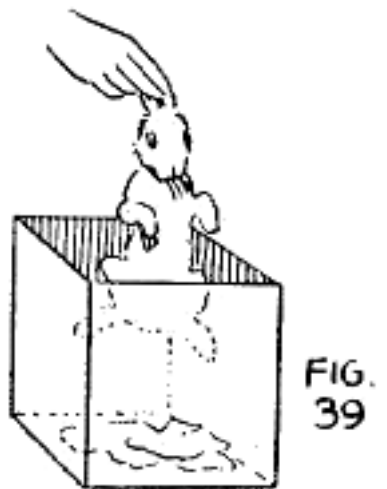


Set box upright again and place lid on it. First put edge (A) down on box. Then as you gradually put edge (B) down, unsnap the fastener and let the rabbit bag sink gently to bottom of box. Let lid come into position over box without hesitating in the movement so that audience does not suspect anything.

Figure 38.

If you have a fan handy, fan the box.

Remove lid and show both sides of it to audience.



Reach inside the box, release the hook and eye, open mouth of bag. Grasp rabbit by the ears and pull him out of the bag and produce him from the box. If rabbit does not slip out easily from bag, use your left hand to help free him. Let the bag remain in the bottom of the box.

Figure 39.

NOTE:

As in the two preceding rabbit effects, this, too, may be presented with patter.

A bit of originality which I used to use with juvenile audiences is this: I would have a plate of small bits of cotton prepared. Then I would drop them into the box and apparently transform them into a rabbit.

A SUGGESTION:

Get a regular size lady's hat box of good quality, such as come from fine milliners. Instead of producing a rabbit, produce a lady's hat. The hat is concealed behind the lid of the box just as the rabbit bag was, attached to a thread and snap fastener. Be careful that hat is small enough to be concealed easily behind the lid.

I performed this effect myself, many times with THREE hat boxes. I showed each one empty and then went from one to another and took out a hat from each. I used

three assistants, each holding a box. You may perform the effect, however, placing the boxes on chairs.

(25-14)

THE "UNIQUE" BOX RABBIT VANISH

This is an interesting variation of the "Modern" Rabbit Box Production in the first part of this lesson.

EFFECT:

Performer shows a rabbit and drops him into a box. The lid is closed, box is removed from table, and given to an assistant to hold. The table on which box was placed is taken apart to show that it contains nothing. Magician then opens the box in which he had dropped the rabbit, and behold! the box is empty --the rabbit has vanished.

PARAPHERNALIA:

- 1 -- Special table.
- 2 -- Special table top.
- 3 -- Special box with hinged lid.
- 4 -- Rabbit.

HOW TO CONSTRUCT THE APPARATUS:

The Table Base: Construct as shown in Figure 1 of this lesson. Nail a block of wood to each corner so that table legs can be screwed into them.

The Table Top: Construct as shown in Figures 2 to 7 in-elusive.

The Rabbit Box: Construct this box the same size as the box in Figure 8. This box is different, however. Hinge the bottom only to the back side of the box, leaving the other three sides of the bottom free. Around the bottom edges of the box put a small strip of wood or metal for the bottom to rest on. Put a knob on the front end of the bottom of box. This bottom should swing up and back so that it is straight up against the back side of box. At the point where knob hits back of box, make a hole or indentation for the knob to fit into.

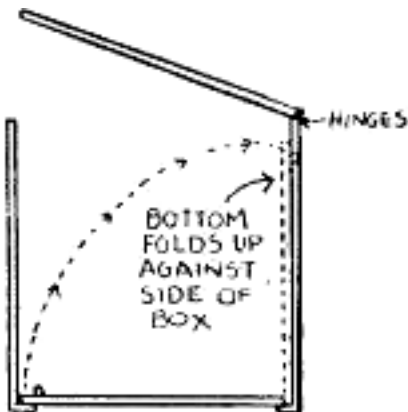


FIG. 40

Figure 40.

From the outside there is nothing unusual-looking about the box. The bottom looks ordinary.

Paint and stripe the box and table to make them look artistic and decorative.

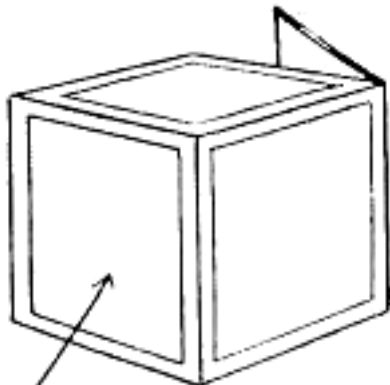


FIG. 41

Figure 41.

MODUS OPERANDI:

To Prepare: Have table base ready with legs on it. Place table top on it.

To Perform: Audience sees table, but believes it to be just an ordinary table.

Bring in box and show it on all sides with lid closed.

Have assistant hold rabbit, or have it nearby.

Place box on table top so that bottom of box covers door in table top.

Raise lid of box. Reach into box with left hand and raise bottom up against back of box. Then open door of table top and raise that up against back of box. Hold these doors in place with left hand if necessary. Take rabbit by the ears with right hand. Show him to audience and place him in the box. Let him sink gently into the bag in the special table top. To the audience, of course, it appears that you put the rabbit into the box.

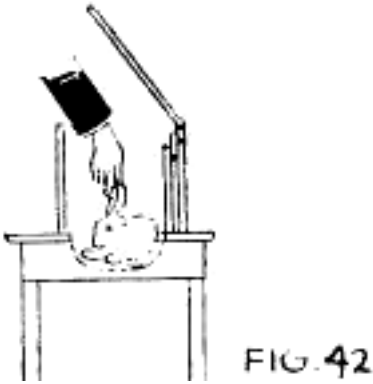


Figure 42.

Allow the door in table top to close, then let bottom of box fall back into place. The rabbit is now safe in the table top. Move the box forward a little so that you can spring the catch on table top door.

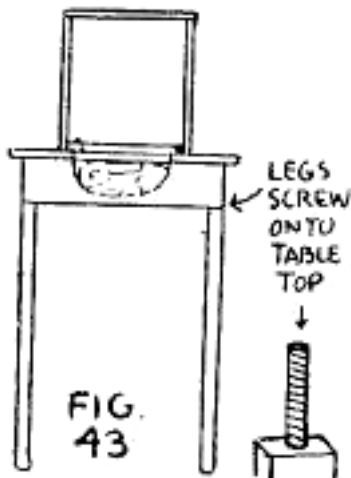


Figure 43.

The detail diagram in this illustration shows how the legs are screwed onto the table.

Pick up box from table and show it all around. Give it to assistant to hold or some youngster who is helping you.



Figure 44.

Take the table top off, raising the rear edge first and holding it vertically to conceal rabbit. Place it against a chair in upright position. Pick up table base and show it freely.

All that remains now is to take the box, open the lid, and show that the rabbit has vanished. If you desire, you may push in the bottom to enable audience to look through box.

* * * * *

NOTE: It will require a little experimenting on your part with catches and knobs. You can try different kinds until you find those most satisfactory. A loop of string sometimes answers as a knob, or sometimes just a tack.

LESSON 26

Amazing, fascinating effects with ribbons! Little, simple ribbons form the basis for experiments which make a tremendous hit with the public.

- 1 - Cutting and restoring a ribbon while it is held by two spectators.
- 2 - Mysterious penetration of a ribbon through a card.
- 3 - Cut and restored ribbon effect of Ellis Stanyon, noted English magician.
- 4 - A SPIRIT MESSAGE.
- 5 - Puzzling transposition of a piece of ribbon from one sealed envelope to another. Envelopes are unprepared, and

may be examined.

(25-16)

SIMPLICITY IS THE KEY-NOTE OF THE TARBELL SYSTEM OF MAGIC

SIMPLICITY is the key-note of this Course in Magic. Every move, every principle has been so thoroughly analyzed and reduced to such simple terms that they are easy to master. The explanation for the working of each effect is so detailed that you can learn it in no time.

That is the wonderful thing about this System. You learn Magic quickly -- easily -- and thoroughly I

The uninitiated man in Magic, of course, has the impression that the explanation and working of Magical effects is very intricate and very difficult, simply because these effects are so puzzling. He also thinks that the Magician has an enormous amount of massive and complicated and expensive apparatus. Then when the beginner in Magic studies the Tarbell System, he finds everything so simple -- he finds the apparatus so easy to make at a trifling cost -- that he is astonished to see how quickly he learns to be a Magician.

There is just one fear in my mind on that score. And that is, that the beginner in Magic, seeing how simple it is, will think that he can't fool the public. Of course, that is an erroneous idea.

REMEMBER -- The simpler the effect, the more puzzling to your audience.

REMEMBER -- The simpler the apparatus you use, the more amazing is the effect.

I have often wished that I could let you witness a performance of the effects I teach you in this Course before I explain them to you. You would be puzzled and bewildered by the mysteries. Then when I teach you the secrets of the experiments, you would give them full appreciation and value, regardless of how simple they seem.

REMEMBER -- In this Course you get practically all of the most baffling effects in Magic.

You get effects which the world's greatest magicians are actually using on the stage today. Effects with which they are making Fame and Fortune. Effects which have come down through centuries and are still profound mysteries to the public. Effects from the Orient which seem like miracles. Original effects with which I have baffled even eminent magicians. From little Impromptu Tricks, through Sleight of Hand, to great Stage Illusions, you get the "cream" of Magic. And if it seems simple to you because of its Scientific Analysis, do not for a moment discount its amazing mystery to your audience!

The famous magicians of the day have all had to learn through experience to value SIMPLICITY. All of them, probably, started with trunkfuls of apparatus, and finally ended up by

carrying their real shows around in their vest pockets. I have thrown away bushels of apparatus, as through my years of experimenting I hit upon easier methods of working effects. Less and less apparatus - easier operation of experiments -- and I have produced some of my finest and most amazing effects.

A well known magician recently told me about a wonderful card effect which he used on his programs. He showed me a piece of apparatus which had cost him about \$500 to perfect. It happened that I had experimented with the same effect when I was 16 years old and had worked out a satisfactory bit of paraphernalia which cost \$2. When I explained to him my simple apparatus, he discarded his own. And why? Because mine was a simple method, more certain in operation, and permitted of much more effective SHOWMANSHIP.

I do not mean to infer by this that elaborate tricks and full stage settings are not effective. They are.

BUT REMEMBER -- Elaborate settings are used in accenting a simple "Ant Hill" Modus Operandi (Method of Working) to produce a great "Mountain" of an effect.

* * * * *

LESSON 26

Five interesting experiments in which a piece of Ribbon plays a prominent part. Because of the colorful effect of Ribbon, it enhances the value of these experiments.

THE CUT AND RESTORED RIBBON

EFFECT:

A bright red ribbon is shown by performer and an end is given to each of two spectators to hold. Showing his hands empty, Magician gathers up the middle of the ribbon and cuts it in half, then twice again for good luck. The pieces fall to the floor. Or, if desired, the ends of the ribbon may be burned. Yet in a moment, the ribbon is completely restored.

PARAPHERNALIA:

- 1 -- A Thumb Tip--This was furnished you FREE with your first box of apparatus.
- 2 -- A piece of bright red ribbon, about 6 or 7 feet long and one-half to an inch wide.
- 3 -- An extra piece of the same ribbon, about 9 inches long.
- 4 -- A pair of scissors.
- 5 -- A small Japanese fan.

To Prepare:

Take the nine-inch length of ribbon and fold it over to make a loop with the two ends meeting. Glue the two ends into the Thumb Tip at the under side. Or if you desire, work two small holes near the under edge of the Thumb Tip. Sew the ribbon to the Tip through these holes.

Figure 1.

Fold ribbon into the Tip so that end of loop comes on top.

Figure 2.

When you place your thumb in the Tip, it goes on top of the ribbon; and when you draw your thumb out, the loop of ribbon is easily pulled out with it.

Figure 3.

Place scissors in upper left coat pocket and fan in a convenient right-hand pocket.

Place Thumb Tip on right thumb as in Figure 3, and have long piece of ribbon in right hand.

To Perform:

Ask two spectators to come up from audience to assist you. Have one stand on your right and the other on your left.

"It is said that Confucius, the great Chinese philosopher and teacher, once wanted to teach some of his students a certain philosophy. He thought the best way to do it was to give them something which they could actually see. So he took a piece of ribbon and asked two students to hold an end each."

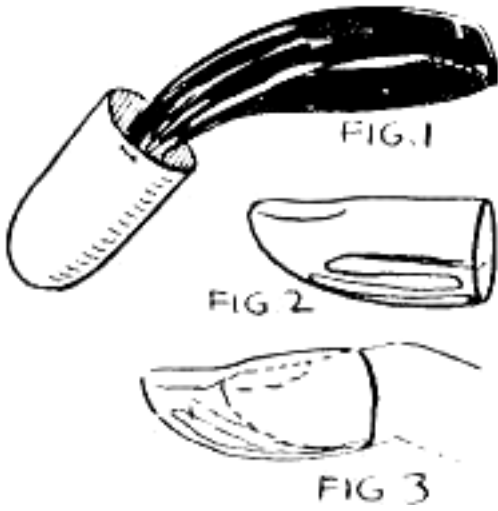




FIG. 4

Give each of spectators assisting you an end of ribbon. You stand behind ribbon and at the middle of it.

Figure 4.

"The way to true friendships," said Confucius, 'is the straight, bright line of understanding.' He went on to say that it too often happens that another mind steps in and tries to destroy friendship."

Show hands empty. Then pick up ribbon at the middle with thumb and index finger of right hand.

Figure 5.

"This disturbing element takes the line of understanding at the middle and holds it in his left hand of trouble-making."

(26-3)

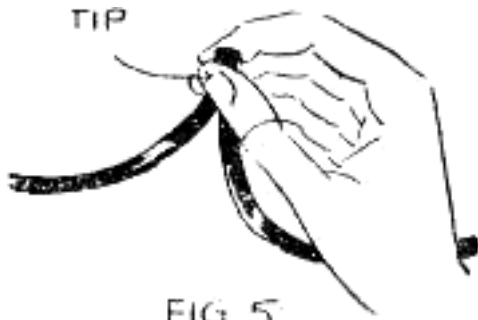


FIG. 5

Place ribbon against palm of left hand.

Figure 6.

Curl left fingers over ribbon. Remove right forefinger from ribbon, then grasp Thumb Tip on right thumb securely in left palm.



FIG. 6

Figure 7.

Withdraw right thumb from Tip, pulling with it the loop of ribbon attached inside. The effect to the audience is that you have pulled the middle of the long ribbon up through your left palm and out between your thumb and forefinger to form a loop. In reality the middle of the long ribbon is grasped in the lower part of your left hand. The Thumb Tip is in the Palm with the loop of ribbon extending out above your hand.

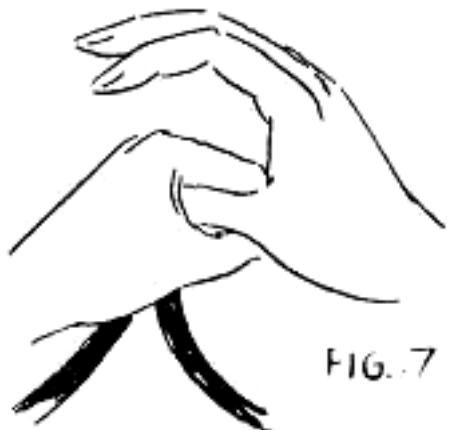


FIG. 7

Figure 8.

Reach into upper left coat pocket and take out scissors.

"Then with the scissors of dissension, he tries to cut off understanding at the middle."

Cut a piece from the loop of ribbon and let it fall to the floor. Then cut the ribbon twice again, letting these pieces fall to the floor.



FIG 8

FIG. 9

Figure 9.

"To make sure his work is well done, you see, he keeps cutting into understanding inch by inch. Then he looks at the two severed ends and smiles and tucks them into his left hand of evil-doing."

Tuck ends into Thumb Tip with right thumb until they are all in. Of course, to audience it appears that you are tucking the ribbon into palm of left hand. Insert thumb into Tip and carry Tip away on right thumb. Show right hand empty by waving it around a little, holding end of Tip toward audience, as you have been taught. Keep your grip on long ribbon in left hand.



Figure 10.

"Then he takes the fan of hate and confusion."

Reach into coat pocket with right hand. Leave Tip in pocket, and remove fan. Open it out.

"And tries to fan in many wild exaggerated tales and suspicions."

Fan left hand a little.

"But the force that rules the universe is peculiar. The very fanning which is supposed to pull friends apart often acts as cement in holding friendship together. And where true friendship exists, all the cutting in the world or the fanning in of misunderstanding will not destroy the true, straight

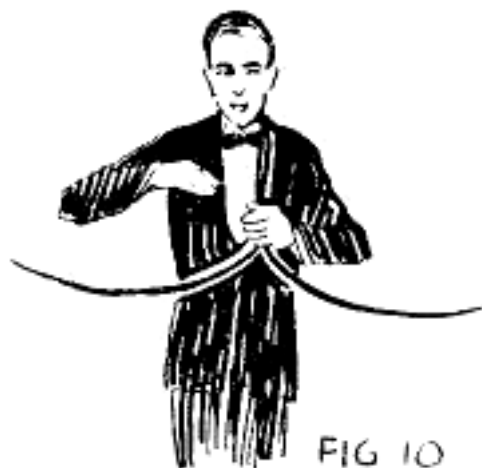


FIG 10

line of understanding built between the two friends."

(26-4)

Release ribbon from left hand and let it fall, stretched out again between the two spectators.

"There is much happiness in the wisdom of understanding. And Confucius without confusion made his philosophy clear to his students."

* * * * *

A CARD AND RIBBON MYSTERY

EFFECT:

Performer asks a spectator to select card from a deck. He then picks up an envelope and a piece of ribbon. Showing the envelope empty, he makes a hole in the center of it with his knife. Through this hole, the ribbon is threaded. The selected card is then dropped into the envelope which is sealed. Magician then states that he will cause the ribbon mysteriously to penetrate the selected card. Envelope is torn open and card removed. Lo and behold, the ribbon is running right through the center of the card!

PARAPHERNALIA:

- 1 -- A double envelope. The same as the envelope used in the mathematical effects in Lesson 8.
- 2 -- A piece of bright-colored ribbon, 4 feet long.
- 3 -- A deck of cards.
- 4 -- An extra card--let us say, the 6 of Spades.
- 5 -- A pocket knife.

SECRET AND PATTERN:

To Prepare:

Take the extra card. Just for example, we shall use the 6 of Spades. Place it in the rear compartment of the double envelope. (We call the two compartments front and rear as they are when you hold the envelope with the flap open and the back toward you. The rear compartment is really toward the front of the envelope.) Have face of card toward inner partition. Seal the two flaps together.

FIG. 11

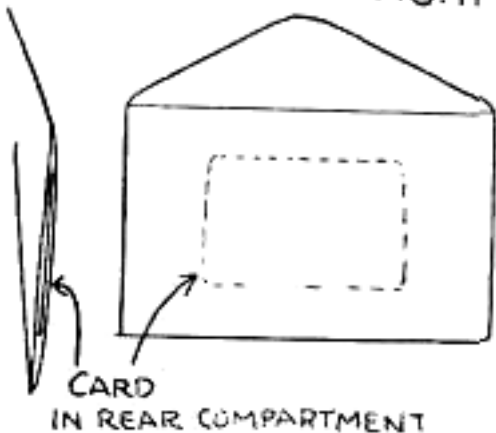


Figure 11.

Take out the 6 of Spades from the deck of cards and place it on "Top" of the deck.

Have prepared envelope, ribbon, and deck of cards on table.

(26-5)

To Perform:

Have spectator come up from audience to help you.

"Science has recently shown that objects supposedly solid are not really so. These solids are really composed of small bits with spaces between. Of course, these spaces cannot be seen. For this reason, a radio wave passes through seemingly impenetrable objects. In Magic we have used these laws of solid through solid for many years. A rather odd example of the working of this law came to my attention in connection with a playing card and a ribbon."

Pick up the deck of cards. Make the REGULAR PASS, bringing the 6 of Spades from the "Top" to the Center of the deck. Make the JOG above this card in readiness for FORCING.

"Any card will answer the purpose. Select one, if you please."

FORCE the 6 of Spades on your assistant.

"What card did you select, sir? The 6 of Spades."

Place the deck on the table. Pick up envelope and ribbon. Open envelope and show it empty.

"Please look in the envelope, sir. You will find it as empty as my pocket. Now to begin with in our experiment, it is necessary to have a hole through the envelope."

Take pocket knife. Push large blade right through the center of the envelope and the card sealed into the fake partition.

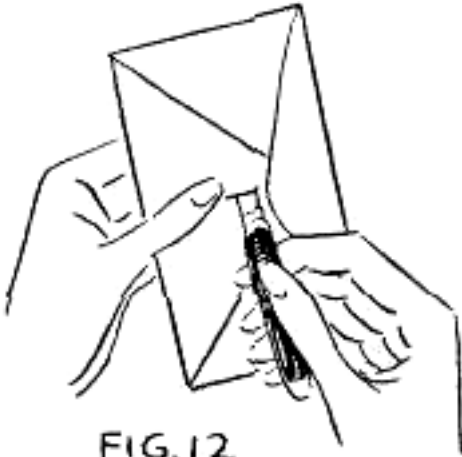


FIG. 12

Figure 12.

"Then we must run this ribbon through the envelope."

With the aid of your knife, push one end of ribbon through the envelope. Draw ribbon through until half hangs down on each side of envelope.



FIG 13

Figure 13.

"When we open the envelope, you can see the ribbon running through both sides."

Open envelope wide so that all can see the ribbon penetrating both sides.

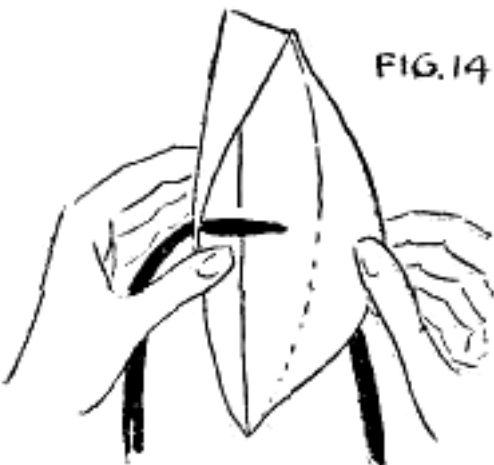


FIG. 14

Figure 14.

"Just an envelope, you see, with a ribbon running through it. Now, sir, if you will let me have the card you selected, I shall place it inside the empty envelope."

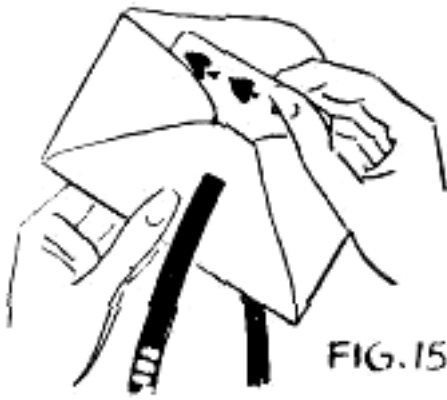


FIG.15

Take card from assistant. Hold envelope and card so that all can see them plainly. Place card inside of envelope as shown in Figure 15.

As soon as you get card into position shown in Figure 15, turn envelope with open flap toward you. Push card down into envelope in vertical position at right end. This brings card away from ribbon in the center of envelope. Audience, of course, thinks you merely continued to push card down in horizontal position as they saw it. Moisten flap and seal. Then turn envelope with flap side toward audience again.

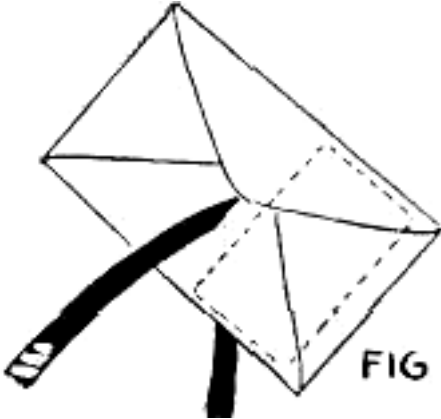


FIG 16

Figure 16.

"You observe that the card has been placed down on the ribbon. This prevents the ribbon from being easily pulled through the envelope."

Pretend to pull on ribbon to show that it does not move.

"In fact, the ribbon is held so tight that it doesn't want to move at all. However, if I pull hard enough, a peculiar thing happens. The ribbon is pulled up into the card, and instead of passing under the card, will pass right through it. Let us try again."

Pretend to pull ribbon again and to have difficulty in making it move. Then really pull it and show audience that it does move now. Pull it back and forth a few times.

"Now, it slides easily."

Tear open the envelope at the end opposite to where the selected card is.

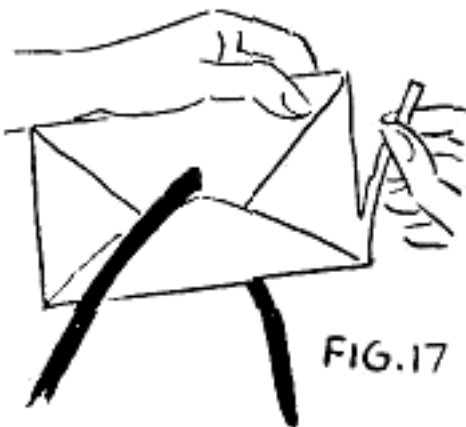


FIG.17

Figure 17.

"We open the envelope and reach inside."

Insert your right fingers into the envelope, spreading apart the compartment containing the card you originally placed there. The ribbon, of course, is running through it. Be careful to push middle partition flat against flap side of envelope with the spectator's selected card between them.

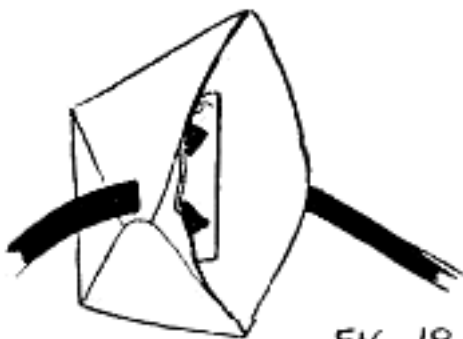


FIG 18

Figure 18.

Show inside of envelope to assistant. Then hold opening toward audience. Show right hand empty, reach into envelope with it and grasp card. Pull card down gradually so that all can see ribbon actually through it and through both sides of envelope.

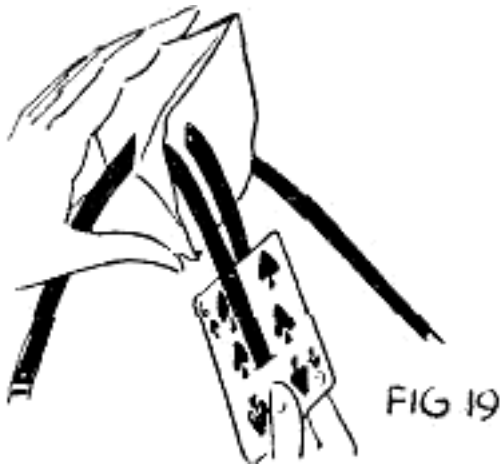
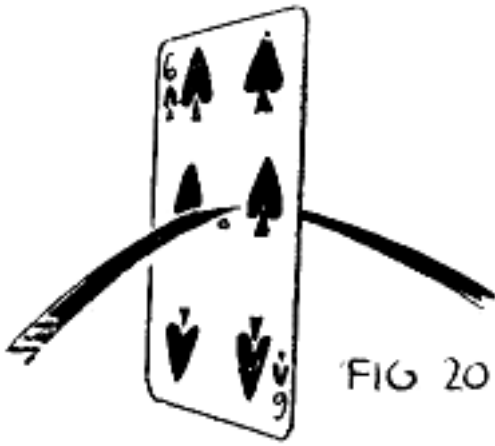


Figure 19.

"If you observe closely, you will see that the ribbon has penetrated the center of the card you selected, sir."

(26-7)



Full card and ribbon free of envelope and show both sides to audience.

Figure 20.

"Proving thereby that things are not always what they seem, and that solid objects can be passed through other solids."

To spectator assisting:

"You perhaps would like to possess this card and ribbon in commemoration of our little tete-a-tete. However, be careful not to explain how we accomplished this experiment."

NOTE:--To facilitate getting ribbon through envelope, you may thread ribbon on a large bodkin and push it through prepared envelope and card that way. When ribbon is through, slip the bodkin off.

* * * * *

THE GHOSTLY RIBBON

(A Mysterious Cut)

This excellent experiment with a ribbon and an envelope is an effect worked out by Douglas Dexter of London. Mr. Dexter is honorary Vice President of the Magic Circle, London.

EFFECT:

Performer picks up a long envelope from which he removes a Japanese fan and throws it aside. He then cuts off the bottom end of the envelope with a pair of scissors. Now taking up a long piece of heavy silk ribbon, he pulls it all the way through the length of the envelope, leaving the ends hanging out. His next move is to cut the envelope in half right across the middle. Much to everyone's surprise, however, when he pulls the two sections of the envelope apart, it is plainly seen that the ribbon is still whole.

PARAPHERNALIA:

1 -- A bright-colored length of ribbon-- about 30 inches long x 2 inches wide.

2 -- A long manila envelope, about 2 1/2 or 3 inches wide and 9 inches to a foot long.

If you cannot obtain envelopes like this at a stationery store, you will find it easy to make them from manila wrapping paper. Cut a strip of paper about 6 1/2 inches wide by 15 inches long. Lap over the two long edges of the paper about one-half inch and fold paper so that this comes in the middle of one side.

3 -- A pair of long-bladed scissors.

Paste these two edges well together. At both ends cut off the seamed side of the envelope about two inches, leaving the other side for flaps. Fold up one of these flaps and paste to envelope. Fold over other end but do not seal.

4 -- A small Japanese fan.

SECRET AND PATTERN:

To Prepare:

Take the envelope and just through the front cut a slit across the middle. This leaves the back of the envelope whole. At each end of the slit cut away a tiny triangle of the paper. This is done to make it easy to insert the point of the scissors and make the cut across the envelope complete in one movement, when you come to that part of the trick. Be careful that these little cut triangles do not show from the back of the envelope.

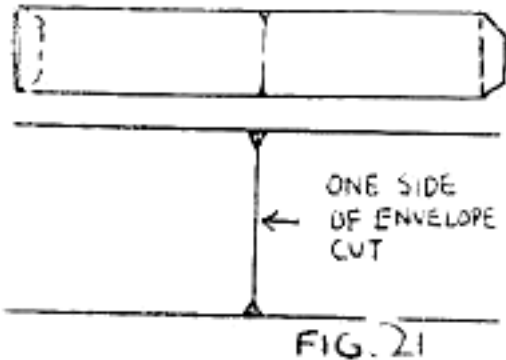


Figure 21.

Insert a small Japanese fan in the envelope to keep it extended and so facilitate the working of the experiment.

Place envelope with fan in it, on table, prepared side of envelope down. Have ribbon and scissors handy.

To Perform:

Pick up envelope with fan. Keep prepared side concealed in hand.

"In life's many illusions, things are! not always what they seem. Things have both a material self and a spirit or ghostly self. When we deal with the latter, we find some interesting phenomena. This brings us to an odd mystery - that of the Ghostly Ribbon."

Open the envelope, remove fan and place it aside. Be sure to keep prepared side of envelope away from audience.

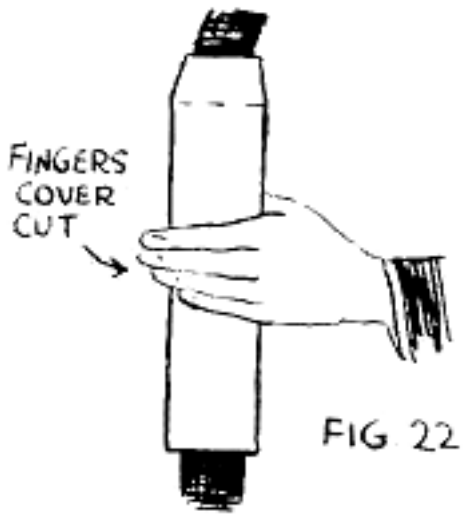
Pick up scissors and cut off the sealed bottom end of envelope.

"This is really a mystery of Old England, involving an envelope with the bottom cut off. The reason for this is to make a tube of the envelope through which a ribbon can be freely passed."

Press edges of envelope a little to make it bulge. Pick up ribbon and insert one end in top of envelope. Let ribbon slide down through whole length of envelope and out the bottom end. Have ends of ribbon extending from envelope of equal length.

Figure 22.

(26-9)



AS AUDIENCE SEES IT

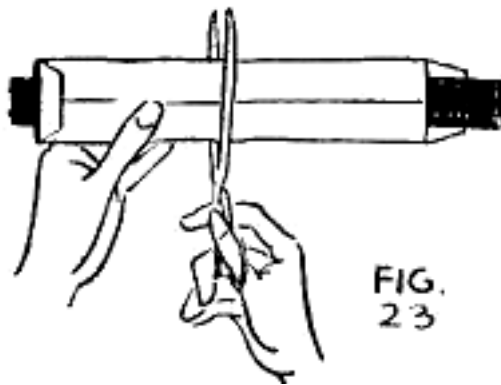


FIG. 23

Take envelope in left hand as shown in Figure 23. Flap end of envelope is toward your right hand. Prepared side is toward you and away from audience. This figure shows how the audience sees the envelope. Insert your scissors ready to cut.

WHAT REALLY HAPPENS

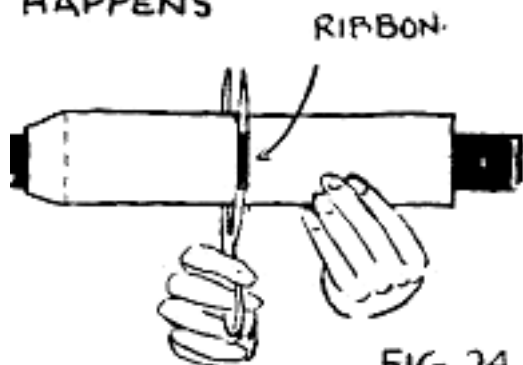


FIG. 24

Figure 24 shows the actual operation of the cutting. This view is toward yourself. Insert one point of the scissors into the bottom of the slit in the envelope. Pass scissors up UNDER the ribbon and out through the top end of the slit. You can readily see that when you cut the ribbon will be unharmed.

"Now we take this ordinary pair of scissors, and with it we cut. There is a peculiar thing about this Ghostly Ribbon, however. It is like ghostly vapor."

Cut envelope in half with scissors. One clean cut should be sufficient to separate it into two sections. Withdraw scissors.

"Unlike the envelope, it will not stay cut, but immediately and invisibly merges into the whole ribbon again."

Separate the two sections of envelope and show that ribbon is still intact. Pull ribbon free of pieces of envelope and show it again.

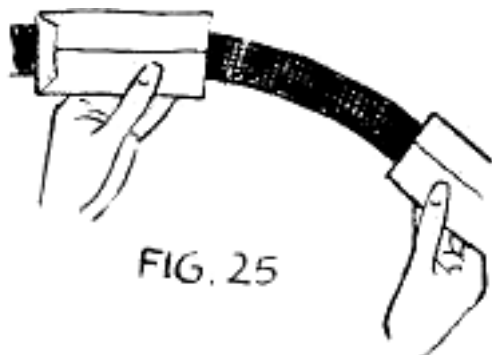


FIG. 25

Figure 25.

"To quote Old Mother Hubbard, 'There are more things in heaven and earth than we have dreamed of in our philosophy.'"

NOTE:—An experiment like this permits of good patter. You may use an old faded ribbon which looks Oriental and build a story around it about ancient times. You might say it was brought to you from an old castle in Persia by a ghost who inhabited it at one time. Or use any original ideas for patter which occur to you.

* * * * *

A SPIRIT COMMUNICATION

In Lesson 8, I taught you THE MYSTERY OF THE TRAVELING NUMBERS. In this lesson I give you an interesting variation of that effect, combining it with the use of ribbon.

EFFECT:

Two pieces of cardboard are shown to be blank on both sides. A spectator is requested to write four numbers, one on each side of the two pieces of cardboard. These slates are then wrapped with ribbon and given to a spectator to hold.

Magician now asks several spectators to write numbers of three digits, one under the other, on a small pad of paper. Another member of the audience adds these numbers. Magician then opens up the package of slates, and inside on one of the card boards has been mysteriously written the sum of the numbers.

PARAPHERNALIA:

- 1 -- Two pieces of heavy white cardboard, about 4 1/2 x 7 inches.
- 2 -- A yard of light-colored ribbon, such as light blue or pink, about five-eighths of an inch wide.
- 3 -- A small pad of paper.
- 4 -- A pencil.

SECRET AND PATTERN:

To Prepare:

THE CARDS:

Take one of the pieces of cardboard and write in the center of it the numbers -- 2285. Make each number 1/2 inch high. Write them with crayon or ink.

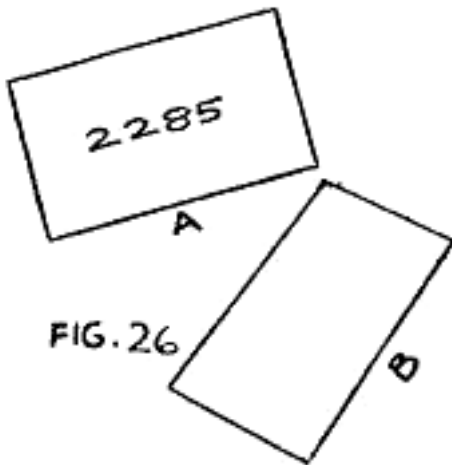


Figure 26.

Place the card A with numbers on it on top of blank card B. Fit edges evenly together.

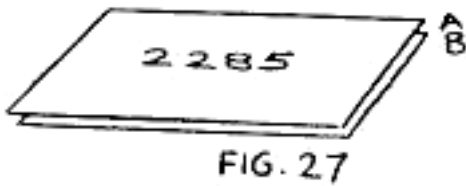


Figure 27.

Take the ribbon and cover the number on the top cardboard with it. Allow about 11 inches of the ribbon to extend beyond the cardboard at the right side and the rest to hang down over the cardboard and left side.

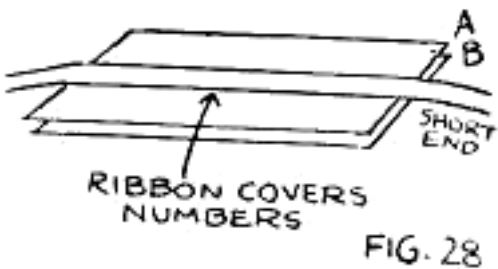
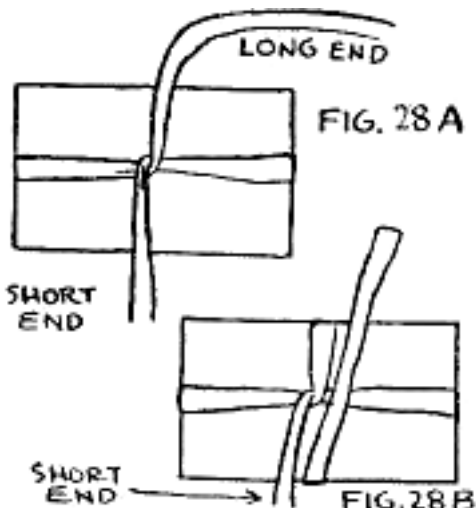


Figure 28.

Now turn cards over and bring ends of ribbon together at the center. Bring left ribbon under right and up around the cards back to the center again.



Figures 28A and 28B.

Tie a bow in the center with the two ends of the ribbon. This knot is, of course, on card B.



FIG 29

Figure 29.

The audience sees two blank cards tied with a piece of ribbon and suspect nothing unusual about them.

(26-11)

THE PAD:

On one side of Pad write in pencil the following numbers under each other, in the same way that you did in preparing the card in Lesson 8:

623

864

921

283

194

See Figure 35 on next page.

The sum of these numbers is 2285, the same number that you wrote on Card A.

Have prepared cardboards on table nearby or in your suitcase and have pad, numbered side down, on table, in your pocket, or grip.

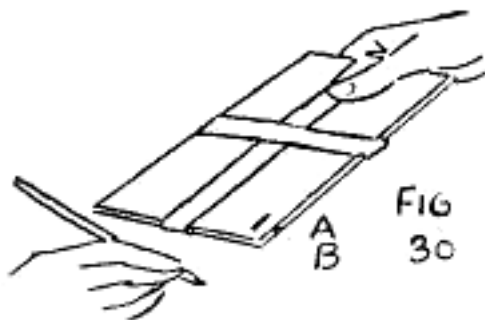
To Perform:

Come forward with package of cardboards. It is well to have a spectator come up to assist you.

"There are some things in Magic which are as mysterious to me as they are to my audiences from the standpoint of scientific analysis And this is one. There was an Old English merchant once who used to keep track of his financial department in an odd way. In a most mysterious manner he could tell just how his business was prospering day by day, even when he was away on a long journey. This was his method. He used to carry with him two pieces of cardboard tied up with baby blue (or pink) ribbon with a pretty bow on them, such as I have here."

To assistant, handing him pencil:

"Please take this pencil. And now I want you to know that these pieces of cardboard are really just pieces of cardboard with a side on each side. I shall ask you to mark all four sides, one at a time. Mark this one here in the lower right-hand corner with the number 1."



Hold slate in front of assistant as shown in Figure 30 and have him mark Number 1 in the lower right-hand corner of this card – the one with the numbers concealed under the ribbon.

"I shall turn the cards over and have you mark this side Number 2."

Turn the cards over so that bow of ribbon is on top, and have assistant mark the number 2 in the lower right-hand corner.



Figure 31.

"That's two sides."

(26-12)



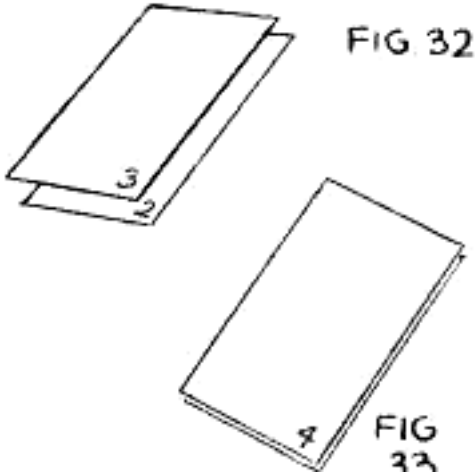
FIG 31

Unfasten the ribbon and remove. Audience sees all of this card B, and it is blank. Take upper card B and place it under Card A with the number 2 still facing upward. This brings the numbered side of card A, which was marked Number 1, between the two cards.

"Now mark the Number 3 on this side in a similar manner."

Spectator marks top card Number 3.

Square cards up and turn both over together so that assistant may mark fourth side.



Figures 32 and 33.

"And finally, mark this remaining side with the Figure 4. Now you have plainly marked all four of the sides, sir."

Move the upper card to the right about an inch and a half to show the Numbers 4 and 1 to audience. Then turn cards over and show the Numbers 3 and 2.

Square up cards again.

"I shall again tie up the cards with the ribbon, and then ask you, sir, to act as guardian over them."

Tie the ribbon around the cards again, making a bow on the side marked 4.

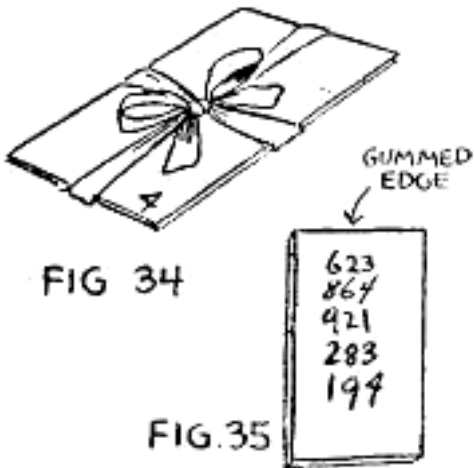


Figure 34.

Give cards to assistant.

Take the prepared pad and hold numbered side against palm of left hand. Hold pencil in right.

Figure 35.

"On this small pad of paper I want several people to write numbers of three digits, such as 689 or 405 - any number you choose. Write your numbers under each other so that we can add them later. I shall ask five people to write any numbers that come into their heads so that you may be convinced that the numbers are absolutely written of free choice by the spectators. Will you, sir, write your number of three digits?"

Hold pad in palm of your left hand while assistant writes his number. Go to four more people and have them write a three-digit number each.

In some cases you may hand pad to spectator as he writes number, but be sure he holds numbered side down on knee or hand. A GOOD MAGICIAN USES JUDGMENT. If he sees any movement to turn pad, he quickly puts his thumb on top and fingers under it, apparently to steady it.

Take pad after five spectators have written numbers and go some distance away to a spectator who does not know what

numbers have been written. Have pad in left hand and drop it to side.

"Who is a good mathematician for adding purposes in this assembly?"

As you say this, turn pad over so that faked numbers are uppermost and spectators' numbers are against palm of left hand. This is very easy to do without being noticed.

Tear off upper sheet of pad with faked numbers.

"Ah, here is a person who looks like a likely mathematical expert. Would you mind just adding these numbers together?"

Draw a line under the figures.

Give pencil and this sheet of paper to spectator. Place pad in pocket.

"Just take care that the total is correct, as it is a matter of grave responsibility."

Say this in a joking way to give a touch of humor to the situation.

"You have added the numbers, sir? Thank you. Now the secret of the English merchant's ability to keep track of his daily business finances every day and to see how much business he did even while he was on a journey was accomplished through the power of the magical cards which the gentleman there holds."

Motion to assistant holding the cardboards tied together.

"All the merchant did was to take these two blank cardboards which the gentleman examined and marked - tied them together -- and left the rest to their mysterious power. Let the numbers which the various people wrote represent the five sales of the day."

To spectator holding paper with list of numbers.

"What was the day's business? How much money did we take in?"

Spectator who added numbers' reads sum.

"Two thousand, two hundred, and eighty-five dollars. Not bad for a day, is it? Of course, that is just one of our light days."

Take paper with figures from spectator so that he will have no evidence left with which to check up later the numbers which other spectators actually wrote.

To spectator holding cards:

"Will you please untie the cards, sir, and look on the inside?"

Assistant unties the cards, separates them, and looks on the inside.

"A number has mysteriously appeared on one of the blank cardboards. Two thousand, two hundred, and eighty-five -- the exact numbers that the sum of the five figures totaled."

Take cards from assistant and show card A with the number on it so that all can see it plainly.

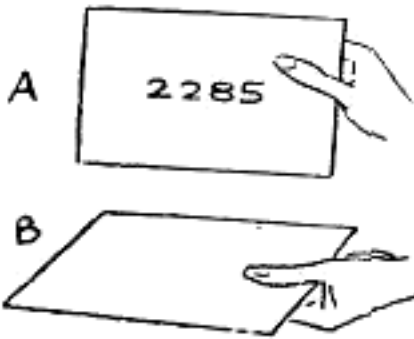


FIG. 36

Figure 36.

"So here was the merchant's secret. His answer was recorded daily on the cards. And now that the business men here have seen this remarkable system, I know that their business methods will be completely revolutionized."

* * * * *

A WANDERING RIBBON

A snappy effect which should be worked in a brisk manner.

EFFECT:

Two envelopes, one pink and one blue, are given out for examination. A spectator seals the blue one and makes a large mark of identification on it. Magician then gives spectator a long piece of ribbon to examine and mark for identification. Performer then places ribbon in pink envelope and seals it in. He shows his hands empty and tears the pink envelope into several pieces. The ribbon has vanished! He picks up the blue envelope, tears off the end, reaches into envelope, and draws out the marked ribbon.

PARAPHERNALIA:

- 1 -- A Thumb Tip.
- 2 -- A piece of ribbon about 18 inches long x five-eighths of an inch wide -- soft ribbon so that it can easily be secreted in Thumb Tip.
- 3 -- Two envelopes, one pink and one blue. These should be opaque. You may use any other colors, just so the two can be differentiated.
- 4 -- A black lithographic pencil.

SECRET AND PATTERN:

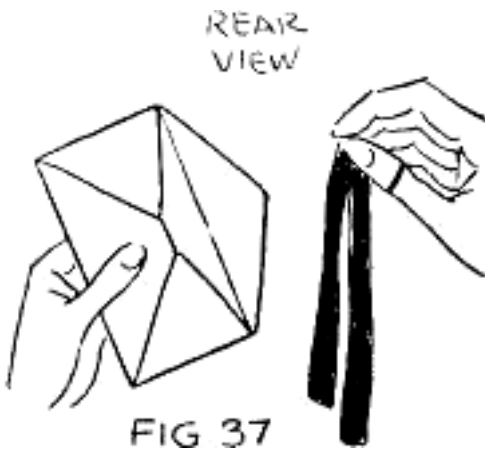
To Perform:

Have spectator mark blue envelope and the ribbon with the pencil -- any mark by which he can identify them.

Show envelope empty, then permit spectator to examine it and seal it. Hold envelope high so that it can be seen at all times and place it standing against some object on table.

Show pink envelope and ribbon in left hand. In the meantime, place right hand in pocket and get Thumb Tip on right thumb while you are talking.

"There is one thing which I wish someone would explain. Why is it that if I Place a red ribbon in a pink envelope ..."



Bring pink envelope in left hand into position shown in Figure 37. Take ribbon in right hand. Be sure to keep Thumb Tip screened behind ribbon and fingers of right hand.

Put thumb and fingers of right hand with ribbon into envelope. Turn to right and hold hands up at right side, so that back of envelope is more toward audience and all can see you tucking ribbon apparently into envelope. Hold Tip in envelope by pressure of left thumb and fingers outside. Remove right thumb from Tip and poke ribbon into it.

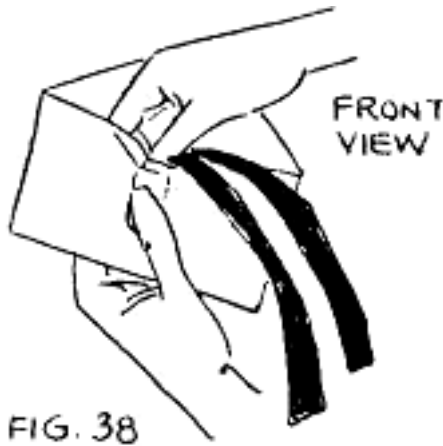
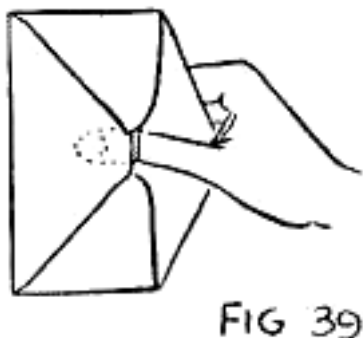


Figure 38.

Be sure to get all of the ribbon nicely tucked into the Tip. On the last poke, insert your right thumb in Tip again. Bring envelope around so that front of it faces audience again.



Remove Thumb Tip from envelope, carrying it away on right thumb. Show right hand empty by pointing thumb toward audience.

Hold envelope in horizontal position in front of you, bringing right thumb with Tip back of it. Moisten flap and seal envelope.

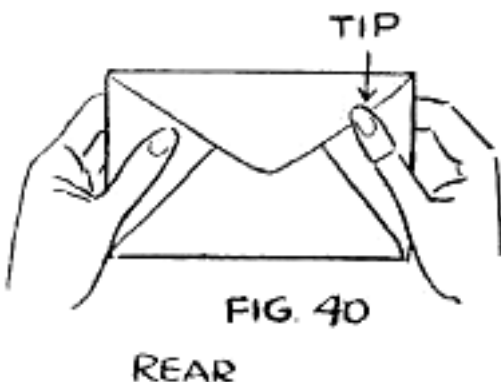


Figure 40.

Show envelope on both sides, then show hands empty with fingers spread wide apart.

"And tear up the envelope ..."

Finger Palm Thumb Tip in right hand.

Tear envelope in half and then into a number of small pieces. Drop pieces on table or let them flutter down onto the floor.

"The ribbon will vanish?"

Insert right thumb into Tip again.

Pick up blue envelope with left hand and show both sides.

"But if I take the blue envelope that the gentleman found empty and then sealed - and tear off the top ..."

Finger Palm Tip again.

Tear off top end of blue envelope.

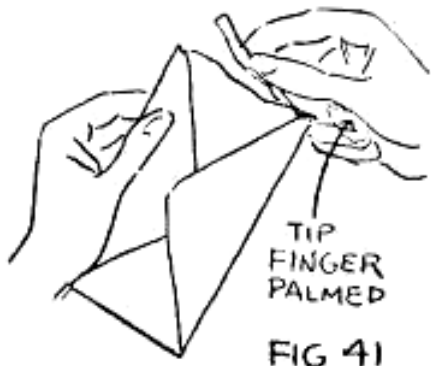


Figure 41.

Replace Tip on right thumb. Show right hand empty. Open end of envelope by bulging it a little with left hand and by inserting fingers and thumb of right.

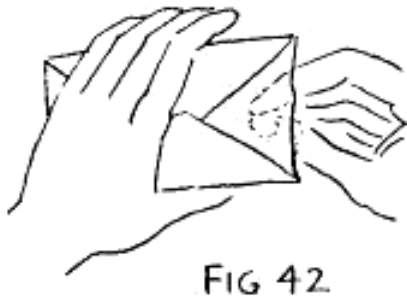


Figure 42.

"And then open up the envelope with the thumb and forefinger of my empty right hand - and reach well within the envelope ..."

Grasp Tip with thumb and fingers of left hand outside of envelope. Slip right thumb from the Tip, grasping ribbon with thumb and first finger. Draw ribbon slowly out of envelope.

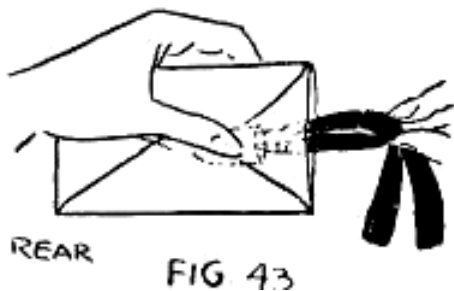


Figure 43.

"We find the Red Ribbon in this Blue Envelope. And it is the SAME ribbon, for here is the mark which the gentleman put on it. Would you be kind enough, sir, to identify the ribbon?"

Pass ribbon to spectator for identification.



Now to dispose of the evidence: You may crush up the envelope with the Tip inside and place it on table. Or if you want to pass the envelope out for examination, transfer envelope from left to right hand, bringing right thumb into the Tip inside as you do so. Then hand the envelope to spectator and carry Tip away and place in pocket. Figure 44.

NOTE:-A similar effect is produced in this manner: Show both lower vest pockets empty. Then tuck ribbon supposedly into left pocket, but really into the Thumb Tip -- just as you did with the envelope. Now show left vest pocket empty and produce ribbon from the right vest pocket. You may permit spectators to examine pockets before the experiment.

Harlan Tarbell

Tarbell System. Incorporated, Chicago.

LESSON 27

Just think! In this lesson you learn the very same effect which the great HOUDINI featured on his programs!--

1 -- The Famous Needle Trick. A package of needles is swallowed with a length of thread. You then reach into your mouth and bring out all the needles strung on the thread. This is the effect Houdini made famous!

2 -- A Thimble Act. Manipulation of thimbles and interesting effects using them.

First in this lesson, I give you the Famous Needle Trick. The eminent Houdini featured this wonderful effect on his vaudeville programs. He studied it detail by detail from the standpoint of SHOWMANSHIP, and in his hands it became a masterpiece. You, too, must study this effect carefully to make your presentation of it a thing which will make your audiences long remember you.

EFFECT:

From one to five packages of needles are shown. Needles are removed from packages and placed on performer's tongue. He swallows the needles and shows his mouth empty. Then magician swallows a yard or two of white cotton thread. He drinks some water to help his swallowing. Next he shows his hands empty, reaches into his mouth, and grasps an end of the thread. He pulls it slowly from his mouth, and to the amazement of all, the needles are threaded one by one on the thread.

PARAPHERNALIA:

- 1 -- Two packages of needles. Size 5 is suitable. You can determine by experimenting just what size you can handle best.
- 2 -- A spool of white cotton thread.
- 3 -- A glass of water.

SECRET AND PATTERN:

To Prepare:

(Note: Houdini apparently swallowed FIVE packages of needles, but to begin with, I shall teach you how to work with one package. As you become more proficient, you may add more needles to the trick. If you use more needles, remember to use longer thread.)

Take the two packages of needles. File the points down on all the needles except ONE. They must be blunt so that they will not prick your mouth. Some performers use them with the regular sharp points, but this requires expert handling and is not necessary.

Now in one package replace the needles as they were at the beginning, putting the one sharp-pointed needle on one side. This needle is the one you pass out for examination. Be sure needles look just as they did when you bought them. Close up the package.

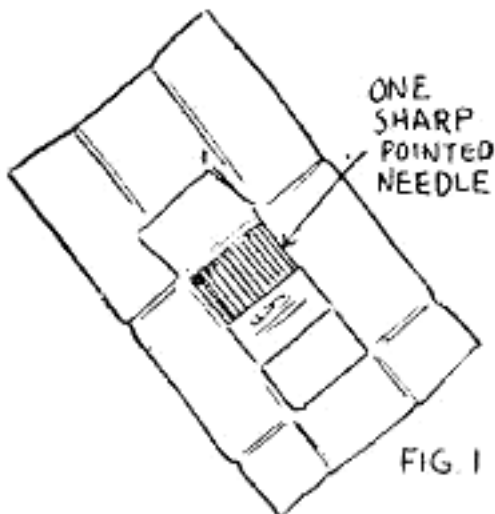


Figure 1.

The other package of needles is threaded on about 4 or 5 feet of thread in this way: Be very careful to follow directions here. About 6 inches from one end of thread, place a needle. Tie a knot on each side of the needle so that it will not slip out of place. Thread the rest of the needles at irregular intervals along the thread, knotting each into place. Leave at least six inches free on each end of thread.

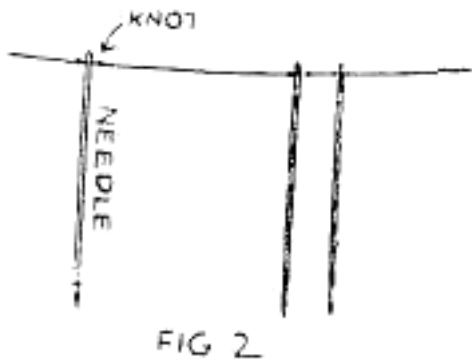


Figure 2.

Now bunch the needles together carefully. Put the heads together, then fold the thread back and forth in zigzag fashion so that it will not tangle. Figure 3. After the last needle is in place, wrap the remaining thread around the bundle and pull about an inch of the end through the middle of the needles. This will keep the thread in place and will furnish an end for you to grasp when the time comes.

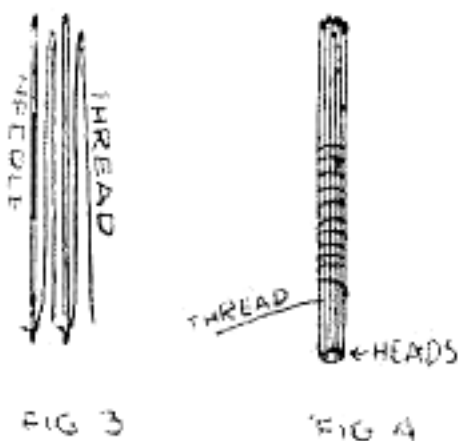


Figure 4.

When ready to perform, place the roll of threaded needles in your mouth between your cheek and the base of your gums on the left side of the lower jaw. Heads of needles should point to the front. Package should be well pressed down into jaw. If needles have been properly prepared, you should feel no discomfort from them. You will also find it easy to talk. Some performers carry the needles so arranged in their mouths for many minutes, so that they do not arouse suspicion just before they perform.



Figure 5.

To Perform:

Come forward with package of needles and spool of white thread.

"Ladies and gentlemen: One of the puzzling features of Oriental Magic is the Famous Needle Mystery. Because of the difficulty in handling needles and the conditions under which the experiment is performed, it truly deserves its place amongst the so-called East Indian Miracles."

Open package of needles and show it.

"I shall first ask someone to see that this is a package of needles."

Go down to audience. Remove the pointed needle from the package and hand it to spectator to feel.

"Just by feeling the point, needles (needless) to say, you soon discover that needles are needles."

Keep rest of needles in package, but show them freely. Allow spectator to retain the pointed needle. Now, say to another spectator:

"Sir, will you please take this package of needles and help me for a little while?"

Give him the package of needles and assist him up to the stage.

NOTE:

It is not necessary to go into audience to show needles if it is not practical to do so on certain occasions. Instead, have two spectators come up to assist you. Give the sharp needle to one, and the package of needles to the other. Have one stand at your right and the other at your left so that the sharp needle cannot be replaced in package by spectators. Should, by any chance, the needle happen to be replaced, just remove the rest of the needles, leaving that one in the package. This will not be noticed by spectators. Also give spool of thread to spectator holding the sharp needle.

"I shall also ask you to hold this thread."

Give spool of thread to spectator who is on stage assisting you. Have assistant at your right.

Have your table with glass of water on it a little in front of you and to your left.

"You, sir, are to act as chief inspector. First, I want to convince you that my mouth is empty."

Open mouth and show all parts. Push lips away from upper and lower gums in front to show there is nothing concealed there. Show space between upper teeth and cheek on each side. Now apparently show spaces between lower jaw and cheek on each side. To do this reach forefingers into each side of mouth and cover bundle of needles with left forefinger. You must do this rather slowly and carefully to convince audience that there is NOTHING in your mouth. Some performers shift needles from lower to upper jaw and back again, but this requires long practice and great care. This other method will prove entirely satisfactory.



FIG 6

Figure 6 shows fingers being inserted into mouth to show it empty.

"Nothing there. Will you please give me the needles?"

Remove needles from package. Be sure to keep them in plain sight all the time until you get them into your mouth. Show the needles to audience, bunch them up together and hold them between thumb and forefinger of right hand. Show to audience again, holding palm of hand toward audience.

Open your mouth and stick out your tongue. Place this bundle of needles on your tongue, heads toward the rear. Move your head around so that all can see needles on tongue. Show to assistant also.



FIG 7

NEEDLES
PLACED
ON
TONGUE

Figure 7.

Now close mouth and with the tongue force the needles over into the space between cheek and lower jaw on right side, opposite to side where prepared needles are concealed.

(27-3)

Pretend to swallow needles. Making a swallowing motion to create the illusion of swallowing the needles.

WARNING:

Do not throw your head back, for there is danger of your actually swallowing some needles. Some performers do throw their heads back in pretending to swallow the needles, but it is unwise for you to do so. You can get the same effect by leaning your head forward. Get the needles into position and then straighten your head. It will appear that you did lean your head back somewhat to swallow.

After this maneuver, sigh and say:

"Not so bad at that. Now for the thread."

Break off about the same length of thread as the one on which you have the needles threaded. Roll up about 12 inches of it into a ball and place in your mouth. Then gradually draw thread into mouth with chewing motion. Be sure not to have hands come near mouth during needle swallowing or eating of thread.

Figure 8.



It is easy to get thread into a small wad in your mouth and to force it over on right side with the unthreaded needles. Figure 9 shows positions of bundles of needles—prepared ones are on the left side, unprepared ones and wad of thread on the right.

Note: When working with more than one package of needles for swallowing, each package is apparently swallowed one at a time. In reality, each bundle is pushed over to lower right side of mouth between jaw and cheek and stacked together there. It takes skill to work with several packages, so do not attempt it until you have mastered working with the pretended swallowing of one.

"Rather a light dessert for a needle meal."

Pick up the glass of water and drink some of it.

"That is sure to wash the thread down."

Go through movements again of showing mouth empty, hiding both bundles of needles with forefingers. Do this rather hurriedly.

"I am going to ask, sir, that you help me now and be very careful in doing so. What I intend to do is to cause the needles to thread themselves on the thread while in the stomach, and then I shall pull up the thread with the needles strung on it. I shall ask you to take the thread and pull it slowly. Do not jerk. A slight jerk and I might injure my throat. So be careful."

Now make facial motions as though forcing something up your throat. Do not exaggerate these motions.

Show hands empty, fingers wide apart. With first finger and thumb of right hand reach into mouth. Push needles up from left side of mouth onto your tongue. Grasp end of thread and allow bundle of needles to unroll on tongue.

Slowly pull thread out. When about eighteen inches of thread has appeared, have spectator take hold of thread. This leaves your right hand to assist in getting needles out of mouth. When you come to end of string, grasp it in your mouth. Take other end from spectator again and hold in right hand. Hold string of needles straight out with your coat sleeve as a background to show them up better.



FIG 10

Figure 10.

Your effect is now completed, and you may place thread and needles aside.

A THIMBLE ACT

Thimbles may have been designed for sewing purposes, but the manipulative magician has found them very effective in sleight of hand. Every kind from the simple aluminum or silver thimbles to the brightly-colored metal or wooden ones are used. Cardini, the noted English magician, uses beautiful rhinestone thimbles.

Work with thimbles is flashy and permits of beautiful moves as they appear and disappear. They reflect the light and thus are very effective.

As in other branches of manipulation you have the three fundamentals in thimble work:

- 1 - Production, or appearance.
- 2 - Vanishing, or disappearance.
- 3 - Transformation, or changing.

In this lesson I give you a series of moves in such continuous action as to make a pleasing thimble act or combination. You learn to work from a single thimble manipulation to a great production for the climax.

EFFECT:

Performer reaches out into the air and causes a thimble to appear at the tip of his first finger. This is placed in the left hand. Suddenly it disappears—then he finds it at his right elbow. It is thrown upwards and disappears in thin air, reappearing on the tip of the second finger of his right hand. Again magician throws the thimble high into the air and again it is gone—but in a moment it is back on the tip of his first finger. Next, in a most mysterious manner, the thimble becomes red and then changes back to its normal color again. Thimble continues to appear and disappear in bewildering fashion.

It jumps from the first finger of one hand to the first finger of the other hand. Then the spectators gasp in amazement as the magician reaches into the air and a thimble appears on each finger of his right hand, then on each finger of his left hand. He drops the thimbles in a glass on the table. He reaches into the air again and this time four thimbles appear on the fingertips of his right hand, and four on his left hand.

PARAPHERNALIA:

1 -- Sixteen thimbles. Be sure that these fit your different fingers and will not fly off when your hand is in motion. It is well sometimes to file grooves on the inside to give you a good grip. The thimbles may all be the same size except those used for the little fingers. These must be smaller to fit tight.

2 -- A special thimble painted bright red and large enough to fit OVER one of the other thimbles. It is easy to paint an ordinary thimble with bright red lacquer. It dries quickly and will prove satisfactory.

3 -- Special thimble holders.

To be made from cardboard and black elastic tape.

4 -- A glass tumbler on a small table.

SECRET AND PATTERN:

To Prepare:

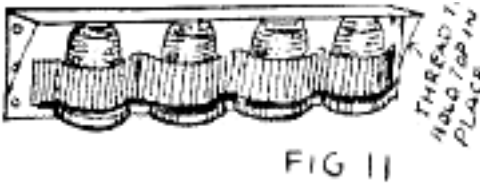
Special Thimble Holder: Take a strip of cardboard long enough to cover four thimbles and wide enough to be bent over the top of the thimbles. Sew four pockets of black elastic tape to hold the thimbles. These must be large enough to allow inserting of thimbles easily and tight enough to hold them securely until needed. Sew a thread from the bottom of the cardboard to the edge of the top to hold top down in place. The purpose of this top is to keep thimbles from pushing out when fingers are inserted. Figure 11 shows front of holder. Figure 12 shows side view of end.

Brass or other metal may be used for this holder. Holes must then be punched in the metal through which to sew the elastic.

Sometimes the holder is omitted entirely and elastic tape is sewn to form pockets for thimbles on under side of vest and coat.

Sew a special holder under left side of vest. Have front end of holder about four inches from front edge of vest and about half an inch above lower edge of vest.

Arrange all holders with openings of thimbles down so that fingers can be inserted in thimbles by curling them under edge of vest or coat.



Under right edge of vest place another holder or sew black elastic tape to vest with pockets for three thimbles. The space between the two end thimbles should be about 2 1/4 inches. A small thimble for little finger should be inserted in right end of this holder and a regular size thimble in the forward pocket.

At left front edge of vest between second and third buttonholes, sew a small pocket to hold a thimble on the under side. You may use an elastic pocket here also. Insert a thimble with open end toward edge of vest so that it can be removed when finger is inserted.

Figure 13 shows the arrangement of thimbles which you have now under your vest. One thimble in a little pocket under the left edge between second and third buttonholes. Three thimbles in a holder under the right lower edge--a small size thimble on the right end of holder. Four thimbles in a holder under left lower edge.



Figure 13.

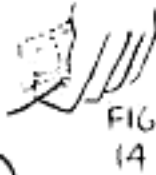


Figure 14 shows position of thimbles and holders under vest.

Under left edge of your coat sew a thimble holder to accommodate five thimbles. Place this about four inches from front edge and about 3/4 of an inch up from lower edge of coat. At rear end of holder insert RED thimble, then small thimble, then three regular thimbles.

Place holder in such position that when arm drops naturally to side, left fingers can curl up under coat and remove thimbles easily on finger-tips.

Have a special holder for four thimbles in similar position on right side under edge of coat.



Figure 15 shows arrangement of thimbles and holders under coat. A holder with five thimbles under left edge--a holder with four thimbles under right edge.

PRELIMINARY SPECIAL PRACTICE WITH THIMBLES:

You must get each move in Thimble Manipulation as nearly perfect as possible. Use your mirror in practicing and work at it earnestly.

There are certain Basic Moves and Principles which you must master before you can begin to think of a thimble act. These are all numbered for you through the lesson. You must practice the first four before you study the actual performance of the whole act.

1 - Thumb Palming a Thimble:

You must be able to bring a thimble placed on the tip of first finger easily and quickly to crotch of thumb.

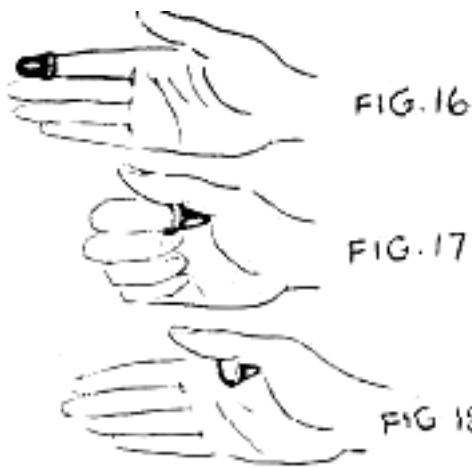


FIG. 16 Study Figures 16, 17, 18 carefully. Notice how first finger brings thimble back to crotch of thumb where thimble is gripped, allowing first finger to be released and to return to first position.

FIG. 17 When thimble is properly Thumb Palmed, it is NOT VISIBLE to audience when back of hand is toward them.

FIG. 18 Practice getting the thimble back on the finger-tip again quickly. Practice this Basic Move with the thimble on the tips of the first three fingers.

PRACTICE ALL THESE BASIC MOVES WITH BOTH HANDS.

2 - Back and Front Hand Palming With Thimble:

This enables you to show both back and front of hand empty and yet have a thimble in your hand.

This move is to bring thimble quickly from Thumb Palm position to back of hand and then back into crotch of thumb again.

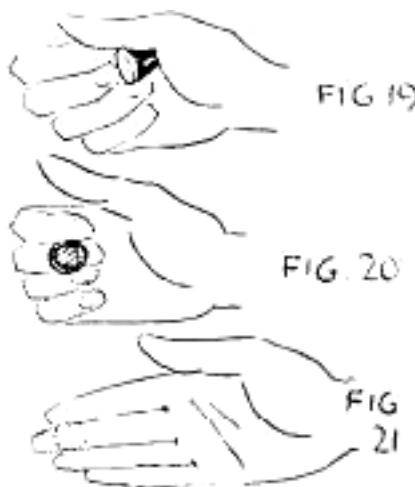


FIG. 19 Thimble is held Thumb Palmed as in Figure 19. Bring all fingers back and grip thimble between first and third fingers. Tip of second finger is in front of opening of thimble. Release thimble from thumb and lift it up in fingers. Second finger goes under opening of thimble and first and third fingers grip edges. Your fingers pivot the thimble slightly to bring it into this position resting flat on second finger.

Figure 20.

Extend fingers and thimble is brought to rear of hand, resting on second finger and gripped between first and third fingers.

Figure 21.

Now close fingers into palm of hand again and bring thimble back into Thumb Palm position.

DO NOT READ FURTHER UNTIL YOU HAVE THESE MOVES MASTERED.

If you are going to do thimble work, you must realize the importance of mastering the moves in getting a thimble quickly from the finger-tip to Thumb Palm position, then back to the finger-tip—and also in getting the thimble from Thumb Palm to back of hand and again to Thumb Palm position.

In using Back and Front Hand Palming to conceal a thimble, it is absolutely necessary to study carefully ANGLES OF VISIBILITY and NATURAL COVERING of hand in its motion to screen thimble.



Place thimble on back of hand as in Figure 22. Palm of hand is held toward audience so that thimble is not visible.

Figure 23.



Bring thumb outward and downward, rotating hand with thumb as you do this. Close fingers a little.

Figure 24.



Bring thumb up behind hand and close fingers more, so that you can readily Thumb Palm thimble. Insert second finger in thimble to help you get it into crotch of thumb.

Figure 25.



Open fingers straight out.

Figure 26.



Figure 27 is a detailed diagram showing each motion in accomplishing the preceding manipulation. First, the thimble is grasped between first and third fingers and rests on back of second finger. As fingers curve downward toward thumb, the thimble is pivoted and rotates downward until it is finally inserted on tip of second finger. Then it is thrust into Thumb Palm position. This diagram is a side view.



Figures 28, 29, 30, 31 show the movements from the rear away from the audience. Study these illustrations closely until you understand them perfectly and can perform the moves without hesitation.

Now with thimble Thumb Palmed you can show back of hand empty—and you have shown both sides of your hand apparently empty.

To get thimble from Thumb Palm to Back of Hand again, just reverse the movements.

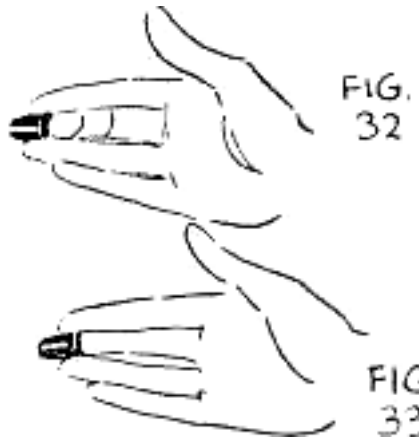
3 - Production of Thimble:

Have thimble on back of hand gripped by first and third fingers. Pull second finger-tip downward and backward, causing the thimble to revolve into position shown in Figure 32. It is now easy to insert tip of second finger into opening of thimble. Thimble is held tightly between first and third fingers so that it can be pressed down well on second finger.

Figure 33.

OPEN FINGERS SLIGHTLY when thimble is adjusted to make a "clean" production.

To facilitate the movement and to cover it slightly, I lower my hand about 12 inches while getting thimble on fingertip. Then I raise hand again and show thimble on finger-tip.



Sometimes I vary the production, however, by holding hand as still as possible and get the thimble suddenly on to the finger-tip.

This SHOWMANSHIP used in varying manipulations is something which you must acquire by experience. It is necessary for successful presentation and gives finish to a performance.

4 - Change-Over Palm:

This manipulation enables you to show both hands empty and yet have thimble concealed. The thimble is changed over from one hand to the other.

To start with, thimble is Thumb Palmed in right hand.

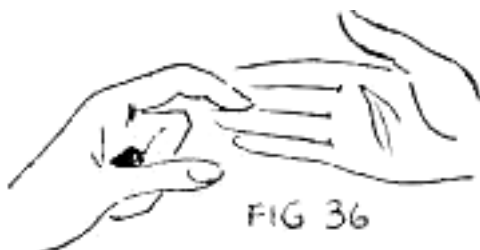


Figure 34.

Look at left hand and bring it toward your right hand until two hands meet in front, backs toward audience. Slip left hand inside palm of right and slip tip of second finger of left hand into thimble.



Figure 35.



Immediately Thumb Palm thimble in left hand by curling second finger down to crotch of thumb and leaving thimble there.

Figure 36.



Continue moving both hands to the right, showing back of left hand and palm of right with fingers apart.

Figure 37.



Figures 38, 39, 40 show position of hands in relation to your body while you perform the Change-Over. First, your right hand with the thimble Thumb Palmed is in front of you. Your left hand is out at your left side with palm shown empty to audience.

Figure 38.



Bring left hand over to right in front of you. Slip thimble onto second finger and Thumb Palm thimble in left hand.

Figure 39.



Continue moving hands to right, keeping back of left hand now to audience and exposing palm of right hand.

Figure 40.

You have now shown both sides of both hands to audience with nothing in them. The Change-Over must be done in one continuous movement with no hesitation so that audience will not suspect anything. Practice Changing-Over the thimble from right to left and from left to right hand.

To Perform:

You are now ready to study the actual performing of your THIMBLE ACT. At the end of this section of the lesson I give you an outline of the whole act. You can then get a mental picture of the whole presentation as your audience sees it and will not be confused by all the moves and manipulations you learn here. Study each move carefully as you go along, and when you have them mastered, the organization and presentation of the whole act will be clear to you.

Turn right side a little toward audience. Reach up into air with left hand as though to catch something. Close hand and then open it again to show nothing in it. This is your MISDIRECTION for getting thimble into right hand.

Follow your left hand with your eyes and audience will do the same thing. Then at the same time curl right fingers under lower right edge of vest. Insert forefinger in middle thimble, remove thimble, and Thumb Palm it. Back of right hand is toward audience and attention is MISDIRECTED by left hand, so you will have no difficulty in doing this without being noticed.

Reach into air now with right hand and bring thimble on to tip of forefinger. You have apparently caught a thimble out of the air. Show it by turning hand back and front.

5 - Slow Thimble Vanish in Hand:

This is so named because of the slow, easy way in which a thimble vanishes when placed in the palm of one hand.

Thimble is on tip of right forefinger. Hold palm of left hand facing audience. Place right forefinger against left palm.



FIG 41



FIG 42



Figure 41.

Close left hand around right forefinger.

Figure 42.

Remove right forefinger, leaving thimble in left hand.

Figure 43.

Then open left hand and show thimble in it.

Figure 44.

This is all done in plain sight of audience.

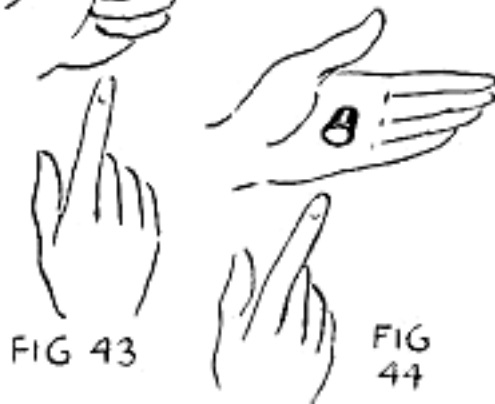


FIG 43

FIG 44

Place thimble on right forefinger again and place it against left palm as you did before. Close left hand over it again, but do not grasp it tightly. Bring right forefinger into a nearly horizontal position. Remove it with thimble still on it from left hand and Thumb Palm thimble quickly in right hand.

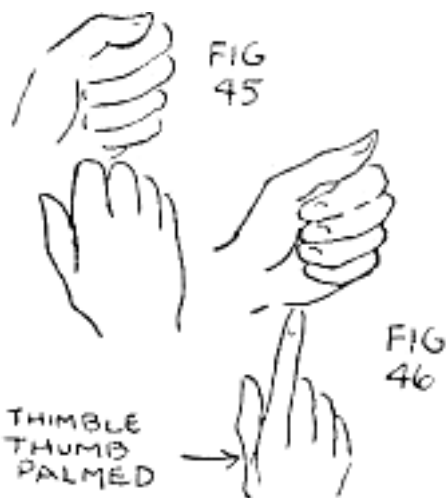


Figure 45.

Immediately bring right forefinger into position shown in Figure 46.

End of right forefinger is away from audience when you withdraw thimble and Thumb Palm it. This move will not be seen by spectators, therefore. To them it will appear that you merely withdrew finger from left hand without the thimble.

Open left hand slowly and audience sees that thimble has vanished.

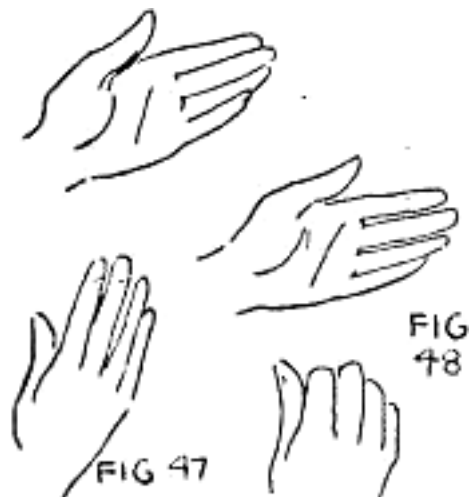
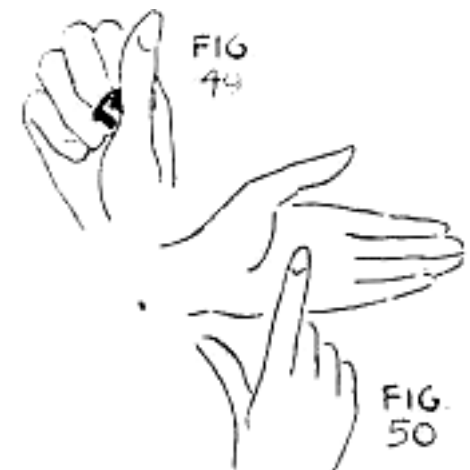


Figure 47.

To help conceal the thimble in Thumb Palming it in right hand, rotate right hand a little toward audience when removing finger from left hand and then raise hand upward a little while Thumb Palming.



6 - Second Finger Hide-Away:

Place second finger of right hand into thimble, freeing it from the Thumb Palm. Figure 48 shows right hand as seen by audience. Figure 49 shows actual move. Place right forefinger against left palm again. Other three fingers are curled down into palm of right hand. Knuckle of second finger is near lower edge of left hand.

Figure 50.

Hands are shown as audience sees them. Palm of left hand faces audience. Back of right hand is toward audience.

Stretch all fingers but the first of right hand out in back of left hand. This move, of course, conceals thimble on second finger of right hand.

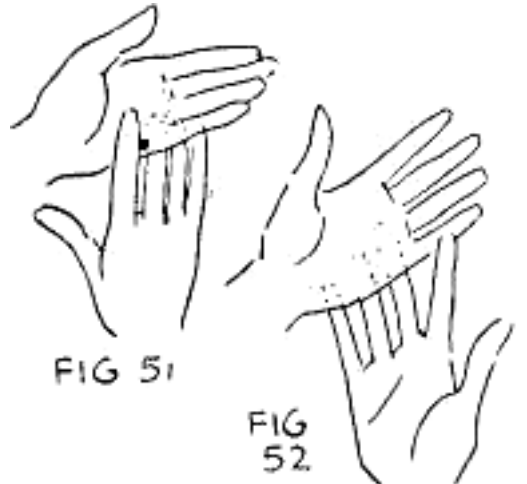


Figure 51.

Move forefinger over to first joint of little finger of left hand so that palm of right hand is shown to audience.

Figure 52.

Bring forefinger back to palm of hand again as in Figure 51. Close three fingers again as in Figure 50. Now show back of left hand and point at it with right forefinger. You have apparently shown both sides of hands with nothing concealed.

Thumb Palm the thimble in right hand again.

7 - Production of Thimble from Empty Left Palm:

Point at palm of left hand with forefinger of right as in Figure 50. Bring left thumb forward and downward to cover right forefinger down to within half an inch of the joint. The moment forefinger is covered, insert it in thimble at crotch of thumb and straighten finger again. Close left hand loosely around this finger and then lift it away from right forefinger and thimble, exposing them.



8 - Pull-Away Thimble Vanish:

Hold hands in position shown in Figure 53. Left hand downward, back toward audience, right hand horizontal with forefinger and thimble pointing to left.

Cover thimble with left hand, closing fingers around it.

Figure 54.

As you close fingers of left hand around right forefinger, Thumb Palm the thimble in right thumb. Figure 55 shows actual move away from audience.

Bring right forefinger back to position again and draw closed left hand away as though you actually pulled thimble from finger and held it in closed hand.



Figure 56.

Open left hand slowly and gracefully and show that thimble has vanished. Open out fingers of right hand also, but keep back of hand to audience.

Figure 57.

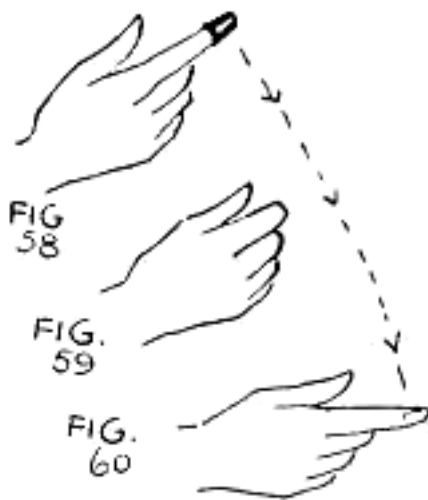
LEARN TO OPEN YOUR HAND GRACEFULLY. This is important for Good Magic and Finish in Presentation. You must use Showmanship to open your hand right-not too fast or too slowly. You can tell a master performer by the way he opens his hand in vanishing an object.

9 - Production from Thumb Palm:

Your next production is from behind your left elbow. Put right hand behind elbow and quickly bring thimble from Thumb Palm position to tip of right forefinger. Elbow need cover forefinger only up to middle joint. Hold hand up to audience to show thimble.

10 - Throw-Away Vanish:

The effect of this vanish which you perform now is that you merely toss thimble into the air and it vanishes.

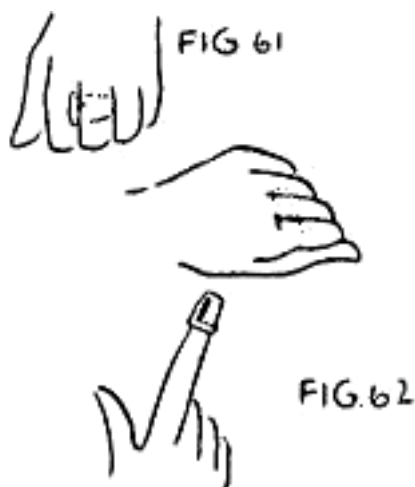


Thimble is on tip of right forefinger. As you make throwing motion and follow imaginary thimble as it goes up with your eyes, Thumb Palm thimble in right hand and bring forefinger quickly back to outstretched position again. Figures 58, 59, 60 show the overhand throw, in which the hand is brought up in pretending to throw thimble and then down as thimble is Thumb Palmed.

The underhand throw is performed by bringing the hand down first before throwing and then upward as you extend forefinger free of thimble and pretend to complete the throwing of thimble.

You must use MISDIRECTION with your eyes as you pretend to throw thimble upward.

AS YOU PRETEND TO THROW THIMBLE UPWARD WITH RIGHT HAND, REACH UNDER LEFT EDGE OF COAT WITH LEFT HAND AND INSERT SECOND FINGER IN RED THIMBLE.



Close fingers to conceal thimble and then get thimble into position shown in Figure 61. This is really Finger Palm position. Thimble is at base of first and second fingers. Opening is toward thumb. Keep red thimble in this position in left hand as you produce thimble from right.

Reach out with right hand and apparently catch thimble from the air. Bring thimble to tip of forefinger and show to audience as if you caught thimble from the air.

Figure 62.

11 - Two-In-One Color Change:

Bring left hand up with back to audience. Bring back of right hand up against left.

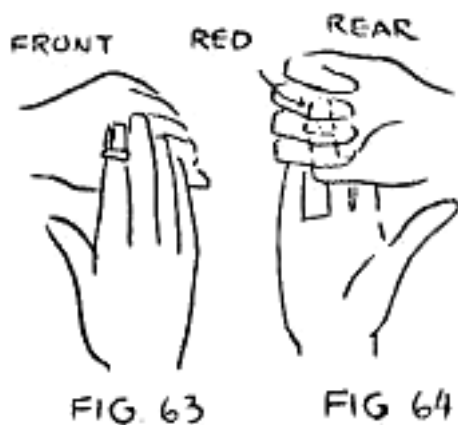
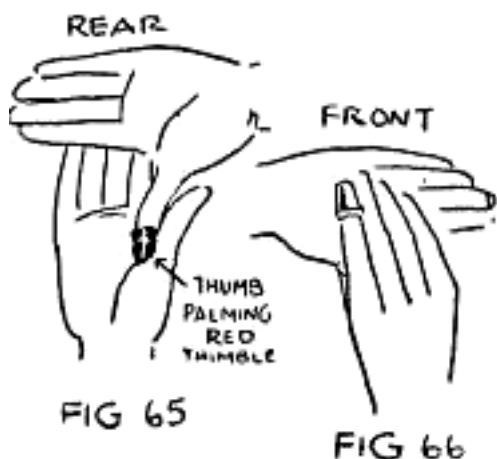


Figure 63.

When lower part of left hand is covered, bend left thumb upward and insert in red thimble.

Figure 64.



Under cover of right hand, bring left thumb with red thimble down to crotch of right thumb and Thumb Palm thimble there.

Figures 65 and 66.

Be careful of ANGLES OF VISIBILITY here. Keep back of right hand squarely before audience. Turn left hand over to expose palm. Place right forefinger against left palm.

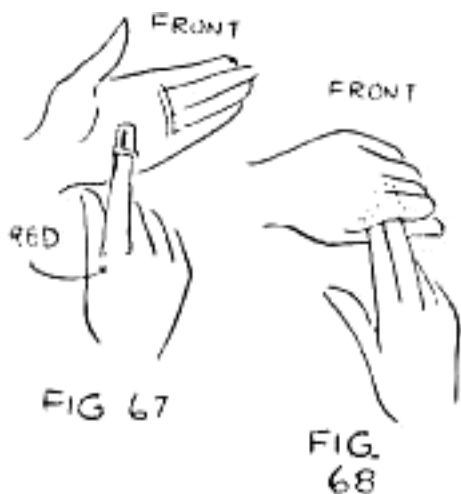


Figure 67.

Now turn back of left hand to audience. Insert second finger of right hand in red thimble which is Thumb Palmed. Bring left thumb forward and down to cover forefinger and second finger of right hand. Under this screen, straighten out second finger, bringing red thimble next to thimble on forefinger. Close left hand around both fingers and thimbles.

Figure 68.

Push red thimble up above other thimble and hold secure by closed left hand. Quickly remove second finger of right hand. This is all done in a few seconds. The effect to the audience must be that you merely covered thimble on right forefinger with left hand.

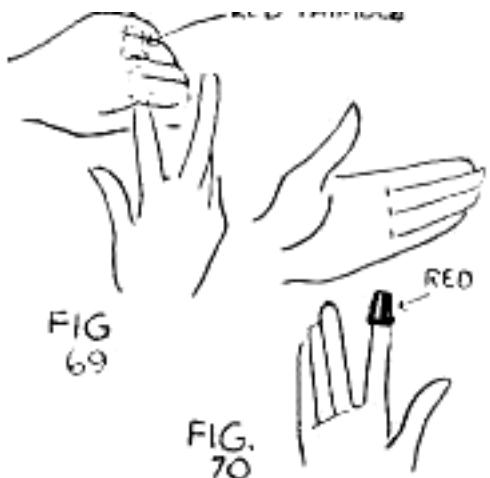


Figure 69.

Insert plain thimble into red thimble with aid of left hand. Now bring right hand down to show that thimble has changed to a red one. Show front and back of right hand. Open left hand and show front and back. There is no other thimble in evidence. The silver one, therefore, must have changed to red.

Figure 70.

12 - Change Back to Original Color:

This is an adaptation of the Pull-Away Vanish to color changing.



Hold hands in position shown in Figure 71.

Left hand downward. Right hand partially concealed behind left.

Curl right forefinger inward to Thumb Palm red thimble in right hand.

Figure 72.

Stretch finger out again with only silver thimble left on it. Remove left hand and turn palm to audience to show it empty. Show silver thimble on right forefinger.

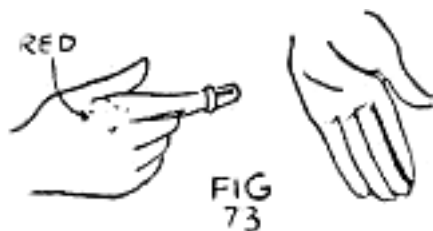


Figure 73.

The effect to the audience is that you merely covered red thimble with left hand and thimble changed back to silver again. This is all done very quickly--in just a few seconds.



Now bring left hand inside palm of right and slip second finger into red thimble. Then Thumb Palm red thimble in left hand.

Figure 74.

Continue moving both hands to the right so that palm of right hand is exposed to audience and back of left hand is toward audience. This is the regular Change-Over Palm.

See Figures 34 to 40.

You still have silver thimble on right forefinger. Drop left hand to side. Turn right side to audience. As you make move of throwing thimble from right hand into air, drop red thimble in left trouser's pocket.

Now vanish silver thimble from right hand as you were taught.

See Figures 58, 59, 60.

Next you produce thimble from behind left knee. With right forefinger extended reach behind left knee. Under cover of knee, get finger into thimble and straighten again. Bring it out as if you took it from knee.

13 - Thumb Down Vanish:

This vanish is similar to the method used for color changing. You have thimble on right forefinger. Show palm of left hand, then turn it with back to audience. Place forefinger behind left hand, closing left fingers around it.

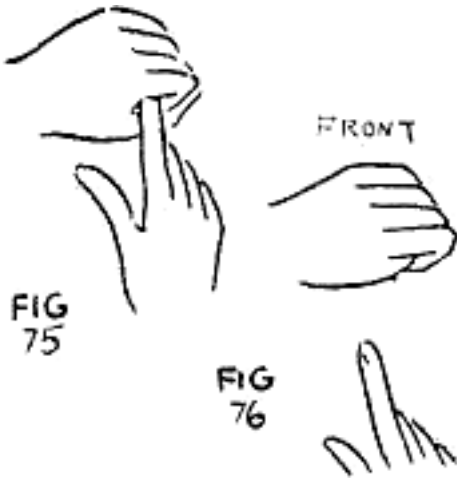


Figure 75.

Remove right forefinger from closed left hand, obviously leaving thimble in left hand.

Figure 76.

Open right hand and show palm to audience to convince them that you left thimble in left hand. While looking at right hand, bend left thumb and insert it in thimble.

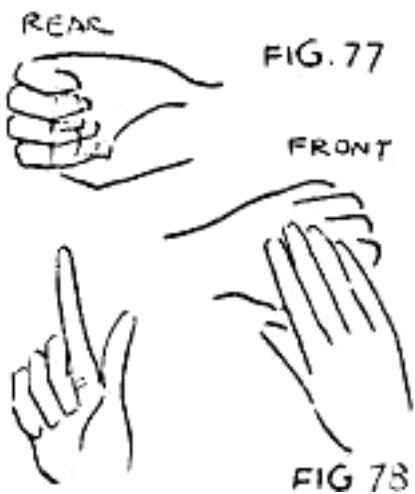


Figure 77.

Strike right hand on back of left. As you do so, bring thimble down in left thumb to crotch of right thumb and Thumb Palm it there.

Figure 78.

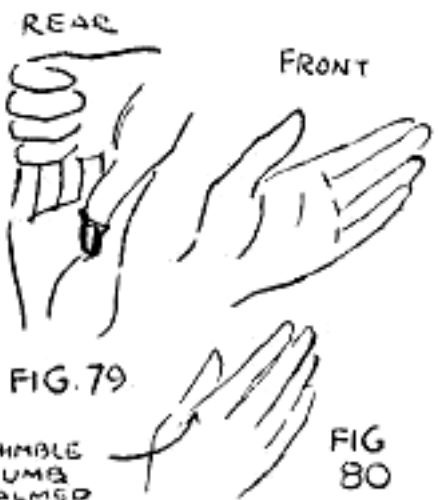


Figure 79 shows actual movement away from audience, in Thumb Palming thimble from left thumb into right hand.

Turn left hand over with palm to audience and point right hand at it.

Figure 80.

The effect to the audience is that you struck left hand with right to vanish thimble, and then immediately turned left

hand over to show thimble had vanished.

Produce thimble at tip of right forefinger from left elbow.

14 - Transfer Color Change:

This is another method of performing the color change. It can be substituted for the Two-In-One Color Change if you have difficulty in getting a thimble to fit over another. It may also be used to change a small metal thimble into a large wooden one. This method may be used for changing a thimble into a small potato. To do this, cut a hole in the potato into which the thimble will fit.

Now, to use it here in the Color Change - get red thimble on tip of right second finger from under coat as you did in preparation for the Two-In-One Color Change. You also have silver thimble on right forefinger.

Place right forefinger against palm of left hand. Other three fingers are curled into right palm.

Figure 81.

Bring left thumb forward and downward, turning hand with back to audience. Let right forefinger with thimble slip around hand to back as it turns. Extend second finger into left palm and grasp red thimble in closed left hand.

Figure 82.

The effect to the audience is that you showed palm of left hand and tapped it with right forefinger, then turned hand and tapped back to show both sides empty.

Release second finger of right hand from red thimble and remove it quickly, leaving thimble in left hand.

Figure 83.

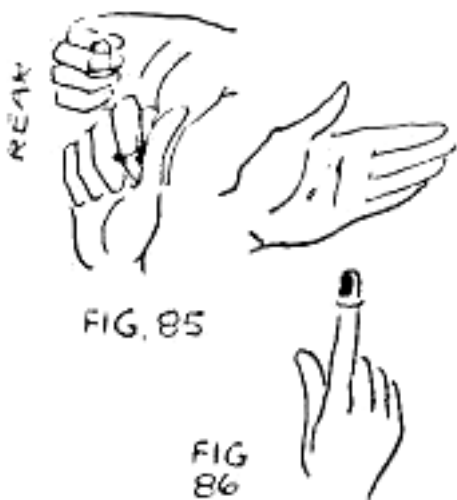
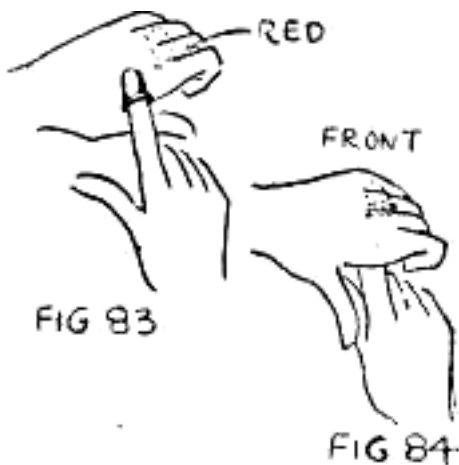
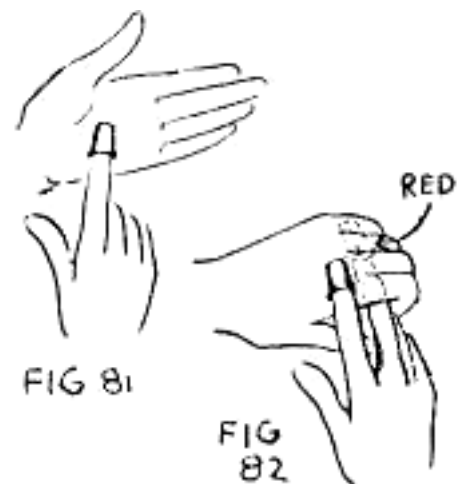
Place forefinger with silver thimble into left hand, and the moment it is screened, Thumb Palm silver thimble in right hand.

Figure 84.

Figure 85 shows actual move away from audience. Still under cover of left hand, straighten right forefinger and insert it in red thimble. Pull right hand away from left. Show red thimble on forefinger to audience. Turn left hand over to show empty palm to audience.

Figure 86.

Silver thimble, which is Thumb Palmed in right hand, may be shifted around from Thumb Palm position to second fingertip so that at intervals fingers may be spread apart and then thumb. When thimble is on second finger, keep finger curled into palm as you spread thumb apart.



To change thimble back to silver again, repeat same movements as used in changing the silver one to red. Blend your movements smoothly into each other and do the changes in a few seconds.

Now, go back to the routine for your Thimble Act again. You have thimble on right forefinger and you are going to use the Back and Front Hand Palming Manipulation, taught to you in the beginning of this section of the lesson.

Back and Front Hand Palming: (Number 2 in your list of Basic Moves.)

Place thimble on tip of right second finger.



Figure 87.

Move hand down about 12 inches and then up again, and under cover of this large movement, press thumb against thimble and aid second finger to slip out of thimble.



Figure 88.

FIG
88



FIG.
89

Slide first joint of second finger under opening of thimble, grasping it between first and third fingers.

Figure 89.

Now open hand and thimble automatically goes behind it and is not visible when palm is shown to audience.



FIG.
90

Figure 90.

Show both sides of hand empty by doing the Front and Back Hand Palming as described in the beginning of this section of the lesson.

See Figures 19 to 31.

Finally, bring thimble to back of hand position and then produce it on tip of second finger as taught you in Basic Move Number 3, Production of Thimble, Figures 32 and 33. Make thimble appear suddenly.

Another good manipulative move --

Reach up with left hand and pretend to take thimble from second finger of right. In reality, Back Palm thimble in right hand under cover of left hand. Bring left hand away from right and open to show thimble has vanished. Show palms of both hands. Then manipulate thimble to Front Palm in right hand and show backs of both hands.

Again manipulate thimble to Back Palm on right hand. Reach into air with left hand, suddenly close it as though grabbing something from the air. Bring left hand to right and pretend to place thimble on second finger of right hand. In reality, you merely produce the thimble on the right second finger from the Back Palm position.

15 - Head Vanish:

Do Pull-Away Thimble Vanish - (Principle No. 8). For variation, hold forefinger in vertical position instead of horizontal. Have finger pointing upward, pretend to remove thimble from it with left hand - in reality, Thumb Palm the thimble in right hand. Then bring closed left hand suddenly down on top of head, opening hand as you do so to give effect of pounding thimble into head.

Figure 91.

You now produce thimble from mouth. Bring right hand toward mouth, and as you do so, insert forefinger into thimble.

Figure 92.

When hand is about two inches from mouth, stretch out forefinger and push thimble into mouth. End of finger is away from audience and hand is in motion so that thimble cannot be seen. To audience it appears that you put your forefinger

with nothing on it into your mouth.

Figure 93.

Remove forefinger from mouth showing thimble on it. Apparently thimble went through your head down to your mouth and from there you produced it.

Figure 94.

16 - Mouth Vanish:

The effect is that you show thimble on right forefinger, place it in mouth, show thimble in cheek, and then swallow it.

Bring forefinger with thimble up to mouth.

Figure 95.

Lower hand and show thimble again.

Figure 96.

Bring hand quickly to mouth. In an instant, Thumb Palm thimble in right hand without stopping motion, and place forefinger in mouth without thimble.

Figure 97.

To audience it appears that you actually put thimble into mouth. Remove forefinger from mouth without thimble on it, of course. Put tongue in cheek to give effect of thimble there. Remove tongue from cheek and pretend to swallow thimble.



FIG 91



FIG. 92



FIG 93



FIG 94



FIG 95



FIG 96



FIG 97






FIG 98

Your next production is from your right ear. Bring right hand up toward ear with forefinger pointing to it. When hand is near ear, curl forefinger into palm and get thimble on finger. Suddenly straighten finger with thimble and insert quickly in ear.

Figures 98 and 99.



FIG 99

Remove finger with thimble and show palm of hand to audience. You apparently took thimble out of your ear.

Figure 100.




FIG 100

Remember that any Production from Thumb Palm which you make or any Thumb Palming of thimble which you do should be covered with a sweep of the hand toward or from object or part of your body. The large motion of arm and hand covers the small one of the actual manipulation. There must be continuous motion - no jerks or hesitation.

Pretend to place thimble in mouth and vanish again. Thimble, of course, goes into Thumb Palm position.

Produce thimble from under right side of vest. Slip thimble on third finger of right hand from Thumb Palm position. You will have no difficulty in doing this with aid of thumb and other fingers.

Curl fingers under right side of vest. Insert little finger in small thimble and slip thimble out of holder. Insert forefinger in front thimble and bring it out and expose it to audience, keeping other fingers still under vest. To help you do this, hold lower right edge of vest with left hand. The effect is that you swallowed a thimble and then produced it from under your vest.

Do the Slow Thimble Vanish in Hand (Principle No. 5). Turn right side toward audience. Place right forefinger with thimble against left palm and vanish thimble by Thumb Palming in right hand. Be sure to keep other fingers with thimbles curled into right palm.

See Figures 41 to 46.

Drop right hand down. Show left palm empty.

Produce thimble from under left side of vest. Curl left forefinger under lower left side of vest and remove a thimble on it from holder there. Bring hand out. Keep other fingers curled into palm and forefinger outstretched so that it is shown to better advantage with thimble on it.

You now have this arrangement of thimbles in your hands. Thimble on left forefinger. Thimbles on third and fourth fingers of right hand. Thimble Thumb Palmed in right hand.

17 - Thimble Jump From Hand to Hand:



FIG
101

Stand directly facing audience. Show thimble on left forefinger pointing upward. Hold right forefinger in similar position. Backs of both hands to audience and other fingers curled into palms.

Figure 101.

Move left hand down about a foot and then suddenly up again. On upward motion, Thumb Palm thimble in left hand. Straighten forefinger immediately again. Effect is that thimble has suddenly vanished from left forefinger.

Now do a similar movement with right hand—down and suddenly up again. On upward motion, get the Thumb Palmed thimble on right forefinger. Do this in a flash so that it will not be noticed by audience. Straighten finger immediately and show it with thimble on. The effect is that thimble vanished from left forefinger and suddenly appeared on right. If movements are properly timed, the effect is that thimble jumps from one hand to the other.

The movement may be varied by holding fingers in horizontal position instead of vertical. Make throwing motions of hands toward each other to cover the small Thumb Palming or Production movements.

Finish with thimble on right forefinger.

18 - Side Swing Jump Over:

This is a variation of the Thimble Jump which you may find it convenient to use sometimes when you have only one thimble in each hand and need not be so careful about not exposing palms of hands.

Show thimble on forefinger of left hand. Point at it with forefinger of right. Keep back of right hand to audience. In right hand you have a thimble Thumb Palmed. Figure 102. Bring left hand to right hand. When both hands are close together, backs to audience, Thumb Palm thimble in left hand and get thimble on right forefinger from Thumb Palm position in right hand.

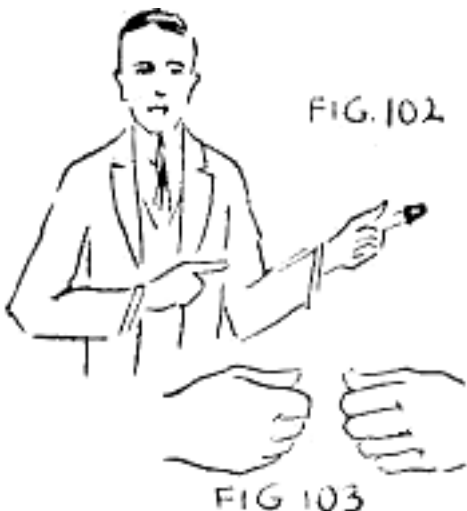


FIG. 102

Figure 103.

Continue movement of hands to right. Now right hand goes out to right side with thimble on right forefinger and left hand points at it.

FIG 103

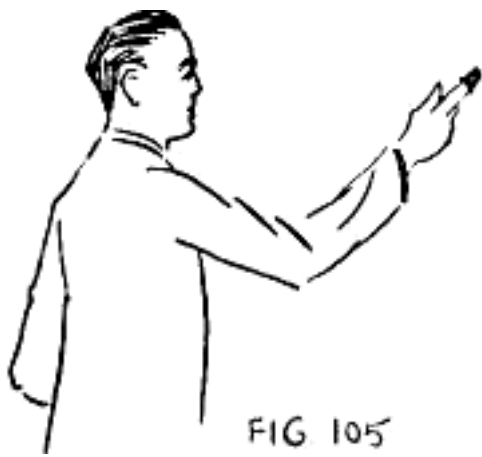


FIG. Figure 104.
104

Effect is that thimble jumps from finger of left hand to finger of right. Reverse movement and thimble apparently travels back to left hand again.

(27-21)

To return to Thimble Act routine:



Turn right side to audience. You have thimble on right forefinger. Pretend to throw it into the air—but, in reality, Thumb Palm it in right hand. Just before doing this get thimble already Thumb Palmed onto second finger of right hand.

Figure 105.

As you make this movement, curl left fingers up under left lower edge of vest and insert them into thimbles in holder there.



Figure 106 shows view away from audience. Your right hand is up. From it you vanish the thimble on your forefinger. This goes into Thumb Palm position. The thimble that was Thumb Palmed goes on second finger. You already have thimbles on third and fourth fingers. Under cover of body your left hand gets four thimbles, one on every finger, from holder under lower left edge of vest.

Keep left hand closed to conceal thimbles and drop to side. Your eyes must MISDIRECT attention of audience to right hand.

Figure 107.

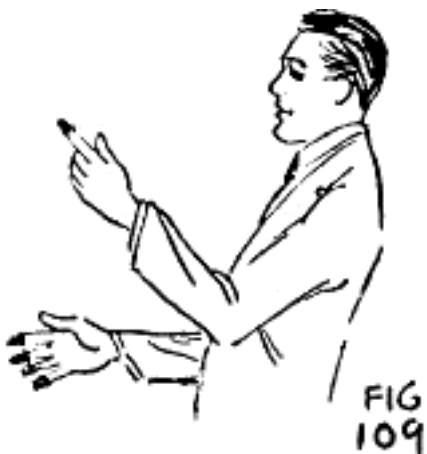
Suddenly pluck thimble out of the air with right forefinger, getting it from Thumb Palm position.

Then suddenly open all fingers and SHOW A THIMBLE ON EACH.



Figure 108.

THIS IS THE FIRST BIG SURPRISE.



Now turn left side to audience, keeping left hand down at side. Thumb Palm thimble from forefinger. Hold forefinger outstretched with nothing on it. Then make sweeping motion of arm, produce thimble on finger-tip, and show to audience.

Figure 109.



FIG. 110

Suddenly open left hand and SHOW A THIMBLE ON EACH FINGER-TIP.

Figure 110.

THIS IS THE SECOND BIG SURPRISE.

(27-22)



Drop thimbles from right hand into glass on table. Let right hand fall to side. Then drop thimbles from left hand into glass. To do this, turn left side to audience.

Figure 111.

Curl right fingers under lower right edge of coat and insert them in thimbles in holder there. Remove thimbles on finger-tips and keep hand closed and down at side. This view is away from audience.

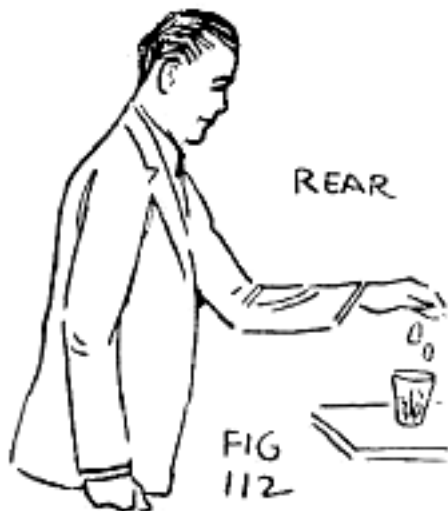


Figure 112.

Turn right side to audience now. Keep back of right hand to audience and Thumb Palm thimble on forefinger.

Now reach into air with right forefinger outstretched and nothing on it, and catch a thimble on the finger-tip.

With right side turned to audience and the use of MISDIRECTION to the right hand, reach under lower left edge of coat with left hand and remove the four thimbles from holder on each of left finger-tips. Thumb Palm thimble from forefinger.

Suddenly open right hand and you again have a thimble on each finger-tip.

THIS IS THE THIRD BIG SURPRISE.

Turn left side to audience. Reach left forefinger with nothing on it into air. Catch a thimble on it.

Then suddenly open rest of hand and again you have produced a thimble on each finger-tip.

THIS IS THE FOURTH BIG SURPRISE.

Drop thimbles into glass, first those from right hand, then those from left.

THIS COMPLETES YOUR THIMBLE ACT.

NOTES:

A Thimble Act of this kind may be finished after the Production of the first eight thimbles—that is, the two surprise productions of four thimbles on each hand. The double production of two sets of four thimbles on each hand, however, gives double the punch to the act. Producing thimbles in such numbers as a finish for the act gives a smashing climax to single thimble sleights. The act may be shortened by omitting some of the single thimble moves.

Trouser Leg Production:

Placing holders with thimbles inside of bottoms of trousers is another method for supplying thimbles for Productions.

Sew a holder of four thimbles inside bottom edge of right trouser's leg and a holder of three thimbles inside left trouser's leg.



FIG 113

Figure 113.

Have thimble on right forefinger and vanish it into the air -- in reality, by Thumb Palming it. Slip this thimble from Thumb Palm on to second finger. Reach up under left trouser. Get the three thimbles from holder on to your free fingers -- first, third, and fourth.

Remove right hand with all fingers curled into palm but forefinger. Show this finger freely with thimble on it. You apparently vanished a thimble into the air and found it again under your left trouser.

Do the Pull-Away Vanish (Principle No. 8) - disappearing thimble from right forefinger supposedly in left hand. You really Thumb Palm this thimble in right hand.

Reach up under right trouser's leg with left hand, get thimbles on all finger-tips, remove hand with fingers curled into palm except for forefinger. Show this freely with thimble on it -- apparently the same thimble which you just vanished in the left hand.

Bring hands to front of body, backs of hands to audience. Do Thimble Jump from Hand to Hand as taught you above. See Figure 101. Perform this two or three times. Then say to audience:

"I just overheard someone remark that I ought to use more than one thimble. I do! I use EIGHT."

Open fingers wide and show all eight thimbles at once -- one on each finger-tip.

Hat Production:

Another method of getting four thimbles. Have four placed inside of the tuck in the crown of a soft felt hat. Have hat on table nearby.

Figure 114.

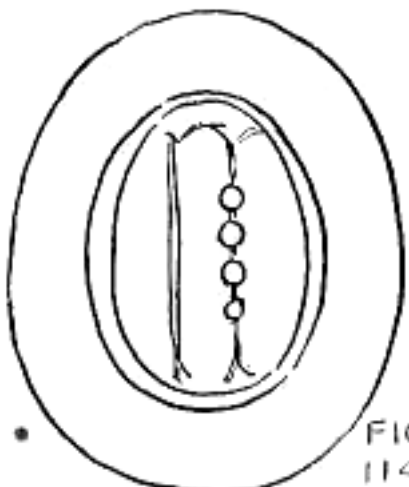


FIG 114



FIG 115

After you have vanished thimble from forefinger of right hand and Thumb Palmed it, reach into hat with left hand and insert each finger into a thimble. Figure 115. Remove hand with thimble on forefinger exposed and other fingers curled into palm. Figure 116. Then make your big production of four thimbles. Or, if you desire to produce eight thimbles from the hat, have three more thimbles concealed in another fold inside of hat. After apparently vanishing a thimble, reach in with right hand, get the three thimbles on fingertips. The Thumb Palmed thimble makes the fourth for the right hand. Suddenly produce these four in right hand. Or, produce all eight thimbles at the same time.



FIG 116

OUTLINE OF THIMBLE ACT:

This outline gives you the sequence of Productions and Vanishes just to make it clear to you the effects which the audience sees as you proceed with your Thimble Act:

- 1 - Reach into air with left hand.
Reach into air with right hand and produce a thimble on tip of forefinger.
- 2 - Vanish thimble in left hand.
- 3 - Show both hands empty.
- 4 - Produce thimble on right forefinger from empty left hand.
- 5 - Vanish it again in left hand by pulling it away from right.
- 6 - Produce thimble from behind left elbow on right forefinger.
- 7 - Toss thimble into air and it vanishes.
- 8 - Produce thimble at right finger-tip again by reaching into air.
- 9 - Change silver thimble to red one.
- 10 - Change red thimble back to original silver one.
- 11 - Vanish silver thimble in air again.
- 12 - Produce thimble on right forefinger from behind left knee.
- 13 - Vanish it by striking right hand on left.
- 14 - Produce it on right forefinger again from left elbow.
- 15 - Vanish thimble suddenly and show both sides of both hands concealing nothing.
- 16 - Produce it on tip of second finger of right hand.
- 17 - Vanish by pounding thimble into top of head.
- 18 - Produce from mouth.
- 19 - Vanish in mouth and swallow.
- 20 - Produce from right ear.
- 21 - Vanish in mouth again.
- 22 - Produce from under right side of vest.
- 23 - Vanish in left hand.
- 24 - Produce from under left side of vest.
- 25 - Jump thimble from hand to hand several times.
- 26 - Vanish thimble from right forefinger into air.
- 27 - Produce it on right forefinger again.
- 28 - First big surprise production--
Four thimbles—one on each of right fingers.
- 29 - Produce thimble on forefinger of left hand.
- 30 - Second big surprise production--
Four thimbles—one on each of left fingers.
- 31 - Drop thimbles from both hands into glass.
- 32 - Produce thimble on right forefinger again from the air.
- 33 - Third big surprise production--
Four thimbles again on right hand.
- 34 - Produce thimble on left forefinger.

35 - Fourth big surprise production--

Four thimbles again on left hand.

36 - Drop thimbles from both hands into glass, and Act is completed.

(27-25)

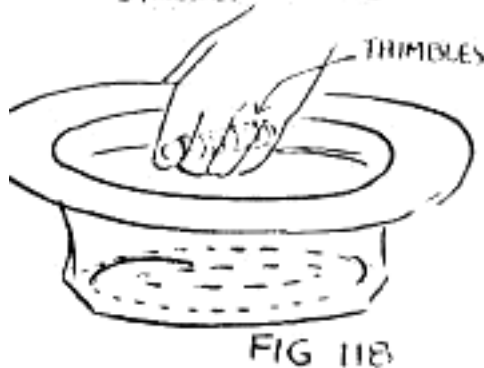
This effect is a variation of THE MISER'S DREAM taught you in a former lesson, using coins. The same principles are applied to the use of thimbles. Review the effect with coins before you study this variation and you will have no difficulty in mastering this new one.



To Prepare:

Stack 12 thimbles inside of each other.

Figure 117.



Hold stacked thimbles inside of hat with left hand. In order to heighten effect of thimbles falling into hat, place a saucer or small plate in bottom of hat and when thimbles drop they will make a good sound.

Figure 118.

To Perform:

A little ingenuity on your part can build up for you an interesting routine with thimbles. Vary it with Front and Back Hand Palming, Throwing thimble into air and catching in hat, Throwing thimble through bottom of hat, etc.

Refer back to THE MISER'S DREAM and use it as a basis for working up a thimble routine.

Here is a suggested routine:

Start with 12 thimbles stacked and held inside of hat in left hand.

1 - Pretend to catch something from the air and to throw it into hat. At the right moment drop one thimble from the stack in left hand. Reach in with right and get thimble on forefinger. Thumb Palm it in right hand and cause it to vanish by a slight upward throwing movement.

2 - Produce this thimble from under left elbow. Pretend to throw it into hat, Thumb Palming it again. Drop thimble from left hand into hat. You now have one thimble in hat.

3 - Produce thimble from left knee. Pretend to drop in hat. Drop second thimble into hat from left hand.

4 - Produce from air. Get thimble on right forefinger from Thumb Palm position.

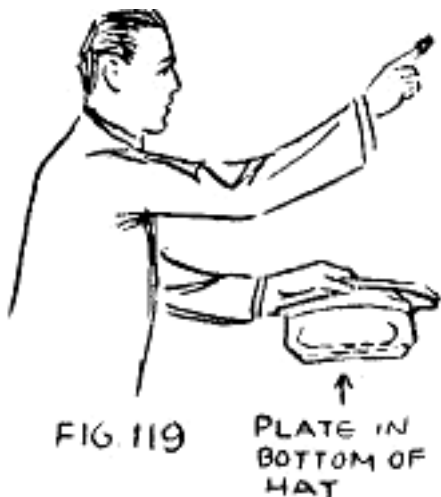


Figure 119.

Now turn left side to audience. Pretend to throw thimble into air—in reality, Back Palm it. Show both sides of hand empty. Then suddenly produce thimble at second finger-tip.

Turn right side to audience. Pretend to push thimble through bottom of hat. Have palm of hand to audience. Bring hand down about a foot, then up to hat, and in a flash Back Palm thimble. At proper time, drop thimble from left hand into hat. This is the third thimble in hat.

5 - Produce thimble from left elbow. Have palm of hand to audience, fingers screened behind left elbow. Bring thimble back on to second finger-tip. Then bring hand out and show to audience. Pretend to drop into hat. Release fourth thimble from left hand.

6 - Produce from ear. Pretend to place thimble in mouth. Place tongue in left cheek to give appearance of thimble inside. Pretend to blow thimble into hat. Thimble is, of course, Thumb Palmed in right hand, and you drop a fifth thimble into hat from left hand.

7 - Catch thimble from the air, producing it on right forefinger. Pretend to throw it high into air. Reach out with hat, supposedly catching it. Release sixth thimble from left hand.

8 - Catch thimble from air again. Pretend to throw into hat. Drop seventh thimble from left hand.

9 - Place right hand at nose. Pretend to blow thimble into hat held underneath. This time allow thimble to fall from right hand into hat. Reach into hat and remove one thimble on right forefinger. Look at it, then pretend to throw it back into hat. In reality, Thumb Palm it, and drop eighth thimble into hat from left hand.

10 - Produce thimble from under side of hat. Pretend to drop into hat. Release ninth thimble from left hand.

11 - Produce from under hat again and supposedly throw into hat. Drop tenth thimble into hat from left hand. You now have one thimble in right hand and one remaining in left.

12 - Produce thimble from behind right knee and pretend to throw it into hat. Drop eleventh and last thimble from left hand.

13 - Reach up as high as you can, standing on your tiptoes and pretend to catch a thimble from the air on right forefinger. Outstretched body gives good effect. Drop twelfth thimble into hat from right hand.

14 - Remove saucer from hat with thimbles on it. Pour thimbles back into hat or into glass on table to show them to audience.

Thimble catching may be elaborated by having holders with thimbles placed at various parts of body. You may place them in this way—one in vest pocket; one in holder under front edge of vest between second and third button-holes; one under right lower edge of vest; one under left lower edge of vest; one in holder under right coat lapel; one in holder under bottom edge of left trouser's leg.

Make your performance of Thimble Productions SNAPPY and put a lot of PEP into the effects.

SOME INTERESTING THIMBLE VANISHES:

Thumb Tip Vanish:

The method is the same as the one used in vanishing a cigarette in a Thumb Tip. See Lesson 2. The bare hand vanish for the thimble is good.



FIG. 120

Figure 120 shows how thimble fits into Thumb Tip.

Phantom Thimble Vanish:

Take a thimble to fit closely on first finger of right hand. Cut it in half lengthwise. It is well to paint the edges flesh color. Place half thimble on back of right forefinger. Figure 121 shows how it fits finger. When front of hand is shown, thimble is not visible.

Figure 122.

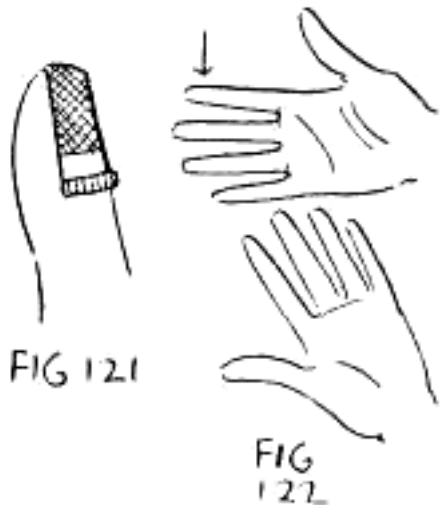


FIG 121

FIG 122

Cover back of right hand with palm of left and turn both hands over so that backs of both face audience.

Figure 123.



FIG. 123

Uncover right hand and expose thimble which has suddenly appeared on right forefinger.

Figure 124.

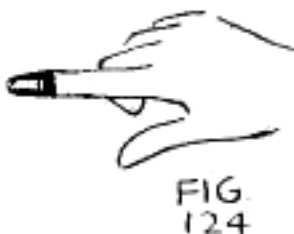


FIG 124

Keep back of right hand well to audience and half of thimble looks like a whole one.

To vanish again, merely repeat motions used in making thimble appear. Cover right hand with left and turn both over to show thimble gone.

You may remove half thimble from pocket and put on back of right forefinger in full view of audience. Then vanish it and make it appear as taught you above. After the last production, just remove it from finger and place in pocket. Audience will not suspect that it is not an ordinary thimble.

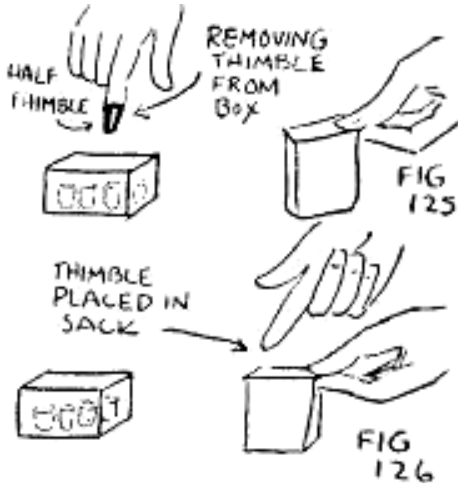
Another Phantom Thimble Vanish. Hold a handkerchief over left hand and make a well in it, as you did in Lesson 2 for vanishing a cigarette by the Thumb Tip method.

Show thimble on back of right forefinger and place it in well of handkerchief. Turn left side to audience. Remove right forefinger with front of it facing audience. It appears that you placed the thimble in the handkerchief. Grasp handkerchief with right hand, being careful not to expose half thimble, and draw slowly from left hand. Thimble has vanished. Leave half thimble in pocket as you place handkerchief there.

Small Paper Bag Vanish:

A pretty little effect. Four thimbles are shown in a small cardboard box. They are removed one at a time and placed in a small opaque paper bag, about 3 inches high, 2 inches wide, and 1 inch across. Paper bag is then torn into bits, and thimbles are produced one at a time from various places on the body.

To Perform: Place four thimbles in a small cardboard box and show them freely. Place on table at your right. Pick up small paper bag and open it, holding it in left hand. Turn left side to audience. Get half thimble on back of right forefinger from right trouser's pocket.



Reach into box on table, showing front of right forefinger to audience. Dip into box and then draw finger out with back turned to audience. You have apparently taken a thimble from box, but, in reality, you just turned your finger around to show half thimble. Figure 125. Place right forefinger in bag, apparently leaving thimble there. Withdraw finger with front to audience and half thimble on back concealed.

Figure 126.

Continue this until you have apparently removed all four thimbles from box and have placed them in the bag.

Turn left side to audience. Reach into coat pocket with right hand for a rubber band and leave half thimble there. Twist top of paper bag and place rubber band around it.

Now suddenly tear up bag into small pieces and let pieces flutter to floor. Thimbles seem to have vanished from the bag. To produce them, merely have four thimbles placed in various parts of your clothing. Produce them one at a time and drop them all into the cardboard box as if replacing them.

Phantom Thimble may be arranged on front of finger and productions and vanishes worked accordingly—producing thimble by showing front of finger and vanishing by showing back.

The Phantom Thimble may be used in many interesting effects. Place four half thimbles on backs or fronts of the four fingers of right hand. Cover them for a moment with left hand, turn hand to make them vanish. Then cover again and turn to produce them. Study your ANGLES OF VISIBILITY carefully in this effect.

Harlan Tarbell

TARBELL SYSTEM, INCORPORATED, Chicago.

LESSON 28

Fascinating Handkerchief Magic—called Magic Silks in the language of the Magician.

1 - An Egg, A Handkerchief, and A Glass. A mysterious transposition of an egg and a silk handkerchief. If desired, a borrowed lady's handkerchief may be used.

2 - A Wandering Silk. It wanders about from pocket to pocket, suddenly becomes untied when knotted, and then changes color.

3 - A series of vanishes, appearances and productions, with a candle and a handkerchief. Amazing effects!

4 - The educated silk which slowly unties itself when knotted right in front of the eyes of the audience.

(27-30)

The subject before us today is Silks.

The silk handkerchief has won its way to a prominent place in Magic. There are several reasons for this—the silk handkerchief makes showy effects; it is easy to handle; and it can be compressed into a small space and then opened to cover a comparatively large space.

The popular size for silks with Magicians is a thirteen-inch square. This is due, perhaps, to the fact that this size cuts nicely from Japanese or Chinese silk, which comes twenty-seven inches wide. Some Magicians prefer, however, to work with larger silks—eighteen inches square, or even twenty-seven inches square for flash effects.

It is easy to make silk handkerchiefs. Buy Japanese or Chinese silk, cut your squares, and hem them around the edges to keep from raveling. Then wash and iron your silks to make them softer and easier to handle. The silks furnished with your course should be so laundered before you use them. Use lukewarm water and a little Lux.

Silks come in so many attractive colors that a Magician can add a colorful flash to his act with them. A European Magician made a hit with a silk effect in which the handkerchiefs had one- to three-inch borders of contrasting color. The light-colored silks had dark borders, and the dark-colored had white or light borders. As a result of this, interesting new effects came into prominence.

Important in silk handkerchief effects is the ability to roll a handkerchief readily into a small ball. The Magician starts with one corner and uses it as a foundation around which to wrap the rest of the handkerchief. To facilitate this, some performers sew a piece of shot or a small button into one corner. Most Magicians, however, find this unnecessary.

Your hands must be kept in good condition for working with silks. They must not be rough or they will catch on the silks. It is well to use Hind's Honey and Almond Cream or any good Benzoin and Almond Cream on the hands just before a performance. These creams give the skin a little stickiness to make it easier to do manipulations. You will find this particularly helpful a little later on when you come to Billiard Ball Manipulation.

THE EGG, THE GLASS, AND THE HANDKERCHIEF

This is another effect which has been handed down throughout the magical fraternity for many years. There have been many methods used to accomplish the effect. Some are rather complicated, involving the use of a hollow wooden or celluloid egg

into which the handkerchief was disappeared and apparently transformed into an egg--and using an extra handkerchief and egg. Of recent years, the Bottomless Glass has been brought into use. It has greatly simplified matters as it requires only one egg and one handkerchief and permits of the marking of both.

The method which I teach you here is simplest of all and just as effective. The experiment is performed with an ordinary unprepared glass, a real egg, and a silk handkerchief (or if desired, a lady's borrowed handkerchief). This method makes the experiment suitable not only for the stage, but for impromptu dinner-table Magic as well.

EFFECT:

An egg is placed in a glass. Performer then covers glass with a pocket handkerchief and places it on the table. A lady's handkerchief is shown (or a silk handkerchief). This is rolled into the hands and suddenly changes to the egg that was in the glass a moment before. Magician removes the handkerchief covering the glass and reveals, to everyone's surprise, the lady's handkerchief or silk one in the glass.

PARAPHERNALIA:

1--An ordinary glass tumbler. The ideal glass to use is one which is straight up and down. If you cannot secure such a glass, one with just a slight slant from top to bottom will do. The goblet with long stem is good as the bottom is usually about the same size as the top. Because of the use to which the glass is put, the bottom must be nearly the same size as the top. A slight difference, however, is all right.

2--An egg (real or imitation).

Other articles, such as a small potato, part of a roll, etc., may be used.

3--A lady's borrowed handkerchief or one of the silk ones which we include FREE with your paraphernalia.

4--A man's handkerchief--large and opaque.

SECRET AND PATTERN:

This experiment is of an impromptu nature and requires no preparation.

To Perform:

Have glass, egg, and large handkerchief on table. Place table at your left and a little in front of you. If you are using silk handkerchief, have it handy. Otherwise, borrow a handkerchief from lady in the audience.

Pick up the egg and hold it in right finger-tips so that audience can see it.

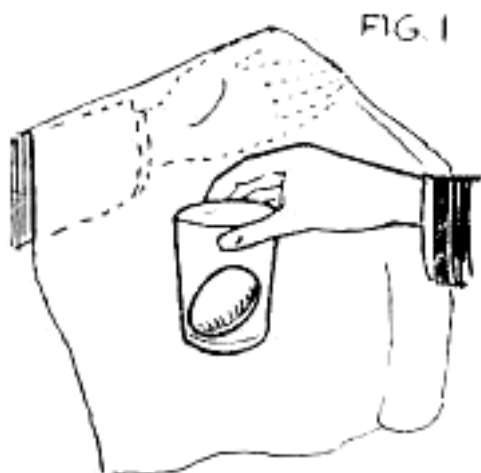
"Old King Cole was a merry old soul, And a happy old egg was he--."

Pick up glass with left hand and show freely. Place egg inside glass, holding glass at upper edge with thumb and fingertips. Shake glass a little.

"Maybe, that's why he lived in a Crystal Palace. See, the King is at home now."

Pick up large handkerchief and spread it over left hand, taking glass in right hand.

"The next scene is the King under cover."



Show handkerchief with palm of left hand under it turned to audience. Then show right hand with glass and egg. Now bring glass directly in front of you and handkerchief on left hand in front of glass to conceal it from audience. Figure 1 is view towards yourself and away from audience.

When glass is completely screened by handkerchief, turn bottom of it up toward the left until glass is upside down. You will have no difficulty in doing this quickly without dropping egg out. Just move your hand and wrist and keep arm as still as possible so that nothing will be noticed by audience.

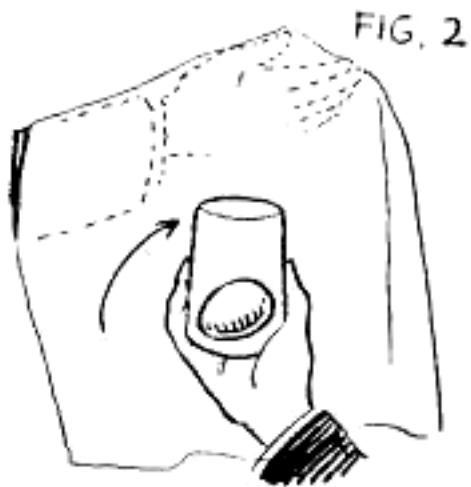


Figure 2.

Cover glass with handkerchief from left hand. To the audience it appears that you merely covered the upright glass with the handkerchief. They do not suspect that glass is upside down.



Figure 3.

Grasp glass and handkerchief at the top with left hand. Allow egg to slide down into right palm and hold it in place by curling second, third, and fourth fingers around egg and pushing it against base of thumb. Remove right hand from under handkerchief, back to audience.

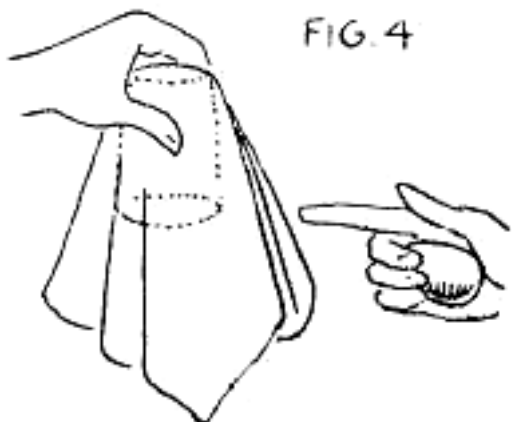


Figure 4.

"Now, we'll set the King's palace down by the wayside."

Place glass on table and let handkerchief drape itself down over it. Top of glass (really the bottom) should be allowed to show plainly under the handkerchief.

Pick up the borrowed handkerchief or silk and hold by two corners as shown in illustration. Keep back of right hand well toward audience.

Figure 5.

(28-3)



FIG. 5

"Pardon me, but did I hear some genial friend say, 'Where's the Queen?' Well....."

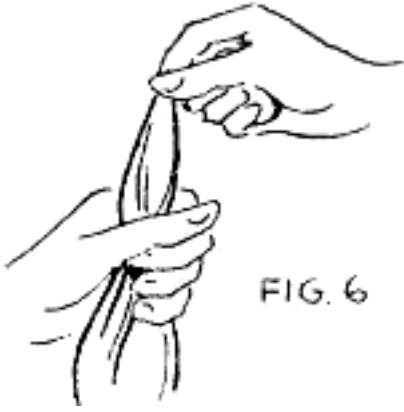


FIG. 6

Allow handkerchief to hang by corner from left hand. Grasp center of it with right fingers and release left hand. Then place left hand around middle of handkerchief as shown in Figure 6.

Remove right hand from handkerchief and point at it with right index finger.

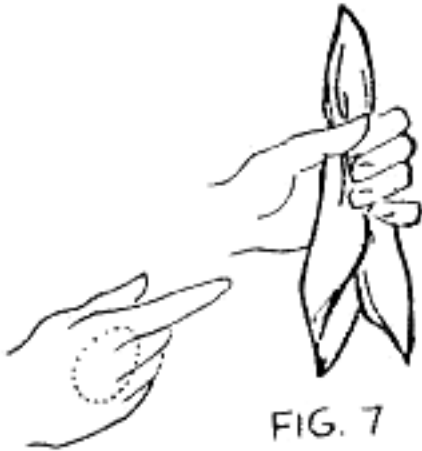


FIG. 7

Figure 7.

"There's the Queen."

Turn right side slightly toward audience. Bring right hand up to left and a little in front of it.



FIG. 8

Figure 8.

Push egg into palm of left hand against the handkerchief and hold it in place with tips of left fingers.

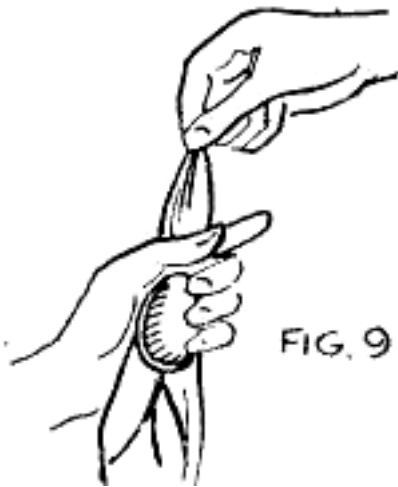


FIG. 9

Figure 9.

Swing hands toward right so that back of left hand is toward audience. Move right hand up to grasp handkerchief at top again as in Figure 6. Study your movements so that they will be done smoothly and without hesitation. It must appear to the audience that you merely reached over with right hand to grasp center of handkerchief sticking up at top.



FIG. 10

Pull handkerchief up and clear of left hand, leaving egg behind in palm of left hand.

Figure 10.

"Some Queen."

Raise fingers of right hand to show palm of hand. This is done to show that hand is empty without saying that it is.

Now bring right hand with handkerchief up to left hand. Swing hands to left so that back of right hand is turned to audience, also your right side.

"Now watch the queen."

With aid of finger-tips and thumb of left hand roll the handkerchief into the palm of right hand. Ball

handkerchief up tight and push securely into right palm. Then curl second, third, and fourth fingers of right hand around handkerchief.

(28-4)

Keep back of left hand well to audience so that egg will not be visible.



FIG. 11

Figures 11 and 12.

Now bring egg up to tips of left fingers and raise hand away from right hand. Point at left with right index finger. Hold left hand up to show egg with palm of hand to audience. Keep back of right hand to audience so that handkerchief will not be visible.



FIG. 12

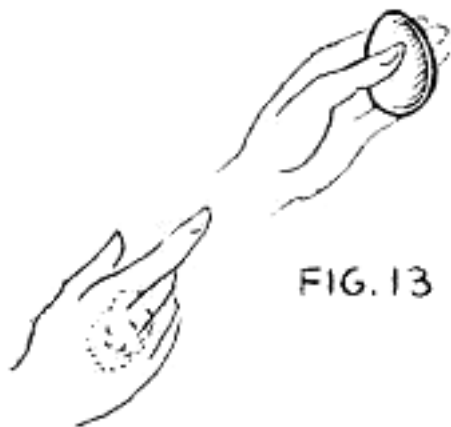


FIG. 13

Figure 13.



FIG. 14

Figure 14 shows how handkerchief is held in right hand. This view is towards yourself, back of hand is toward audience.

"No, you are watching the King!"

Show egg freely and place on table.

"Let us step over to the Crystal Palace."

Pick up glass with handkerchief over it from table. Hold it in left hand. Place right hand under glass and push handkerchief up inside.



FIG. 15

Figure 15.

Let glass rest on right hand, holding it secure with thumb and fingers. Grasp inner edge of handkerchief towards yourself with left hand.

Figure 16.

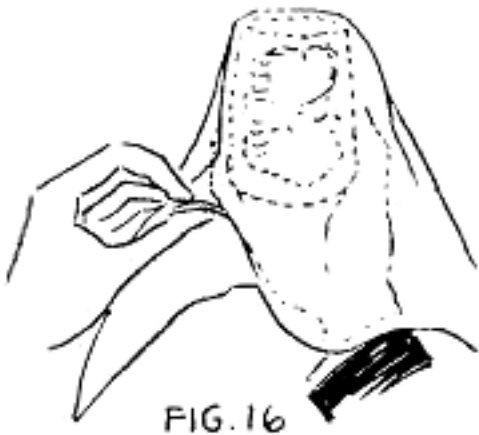


FIG. 16

"We'll remove the cover....."

Lift up handkerchief so that it falls spread out from left hand and still screens glass. Turn bottom of glass toward the left and let glass come back to upright position. If you hold glass correctly by finger-tips, you will have no difficulty in accomplishing this move quickly and easily so that no movement is apparent to audience.

Figures 17 and 18.

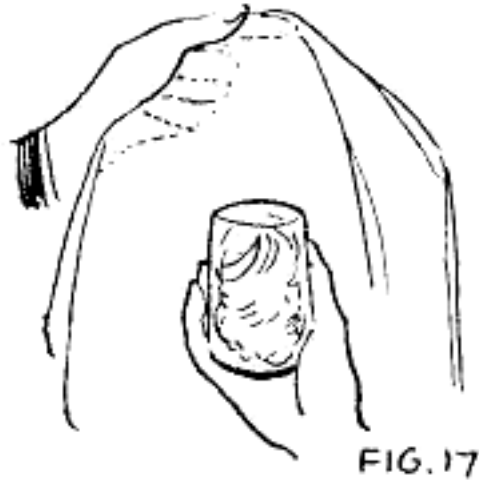


FIG. 17

The moment glass comes into upright position, move right hand to the right to show handkerchief in glass. Drop left hand with other handkerchief out of the way.

(28-5)

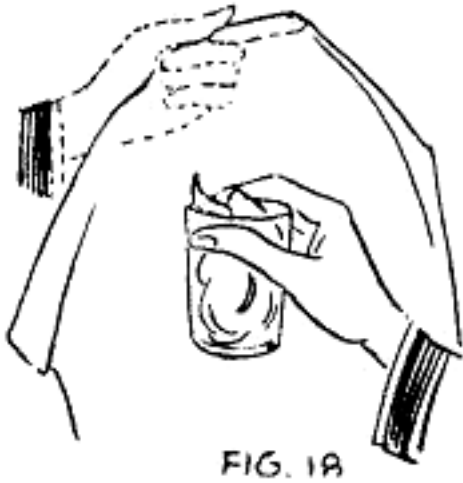


FIG. 18

"And there's the Queen I"

Take glass in left hand. Remove handkerchief from it with right hand. Place glass on table.

If using a borrowed handkerchief, return it.

NOTE:

This principle may be applied in substitution of other articles. A small potato placed in the glass can change places with a radish or lime. A spool of thread can change places with a roll of ribbon. A blue handkerchief placed in the glass may be exchanged with a red silk. It is not difficult to get blue silk out of glass under cover of large cotton handkerchief and rapidly compress it into a small ball into palm of right hand. Three fingers hold it in place as in Figure 14. You will find it easy to change it over to other hand also as you did with the egg.

At the dinner table any small objects may be used for this experiment. Use a glass from the table and a napkin for the cover.

* * * * *

THE WANDERING HANDKERCHIEF

This experiment permits of good SHOWMANSHIP. It is worked under seemingly impossible conditions with a member from the audience watching you closely. And yet it is easy to do and very effective.

EFFECT:

A spectator comes up from the audience to assist performer. Magician turns both trousers' pockets inside out and shows them empty. Spectator also feels in pockets to make sure there is no mechanical arrangements in them. Slowly Magician places a red silk in his right pocket, then reaches into his left pocket and brings out the same silk. Both pockets are again shown empty and performer's hands are shown to conceal nothing. Silk is replaced in left pocket and is again pulled out of right pocket. Once more red silk is replaced in right pocket and appears in left. Assistant is now requested to tie a knot in the silk. It is placed in pocket. A moment later it is withdrawn, and it has untied itself—the knot is gone. Finally red silk is placed in pocket again and is pulled out by spectator. This time it has mysteriously turned to blue. Pockets are still empty.

PARAPHERNALIA:

1--Two Red Silks.

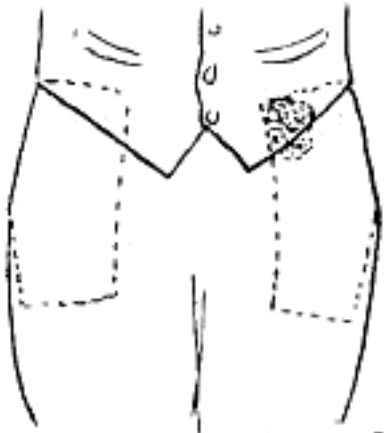
2--One Blue Silk.

These three silks are sent you FREE.

SECRET AND PATTTER:

To Prepare:

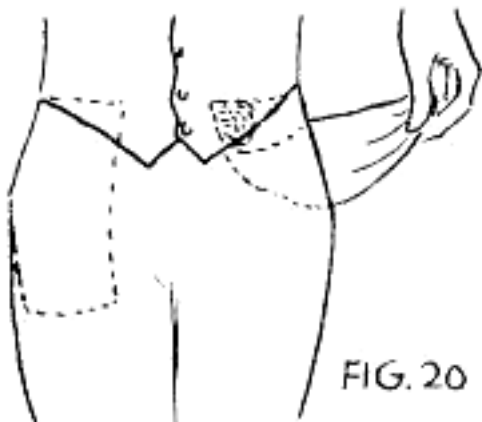
Roll up the blue silk and place it in your left back pocket.



Roll one of the red silks into a ball and tuck it into the upper inner corner of your left side trouser's pocket.

Figure 19.

FIG. 19



You can turn your pocket inside out without exposing the concealed silk.

Figure 20.

FIG. 20

This same principle of hiding an object in the pocket and being able to show pocket empty has been explained to you before in the effect THE CARDS UP THE SLEEVE, Lesson 12, Principle of POCKET CONCEALMENT, Figures 23 and 24.

To Perform:

Have spectator come up from audience. Have him stand at your right.

Bring forth a red silk.

"I am going to ask you, sir, to act as a committee of one to be chief inspector for the audience for this experiment. Do you accept the nomination? Then all is well. This silk handkerchief has very peculiar properties. It acts up in such a way that people imagine I have many kinds of trick pockets with which to fool them. Now you know I wouldn't fool anyone intentionally for the world so I am going to ask you to reach inside my pocket and see that it is just a pocket such as is usually built into trousers."

Have spectator reach into right pocket and feel carefully around to make sure there are no trick devices in it.

"You are satisfied that all is well--that there are no tunnels or subways in it? So that the audience may also join the little game, I will just turn both my pockets wrong side out."



Place silk in right coat pocket. Now turn both pockets inside out. Pull them out far and show both sides. Be careful when pulling left one out not to pull it so far as to expose the silk, but there isn't much danger if silk is properly tucked in corner.

Figure 21.

FIG. 21

"Watch my hands and watch my pockets."

Show hands, both sides, with fingers wide apart. Tuck both pockets back into place. As left pocket goes back into place, reach up with left thumb and pull down the concealed red silk. Push it quickly down into pocket. Anyone reaching into pocket now can readily find silk.

Now take the other red silk from coat pocket and hold it up by corner so that audience can see you have only one silk.

"Just to look at this square of red silk, one would hardly think that it possesses the odd powers which it does. For instance, I place it in my pocket over here on my right side."

Bunch handkerchief up and place into right pocket with right hand. Hold it with thumb and finger-tips and push it into upper inner corner with thumb. Let other fingers come down into pocket so that audience can see movement way down in pocket as if you were pushing silk well down in pocket.

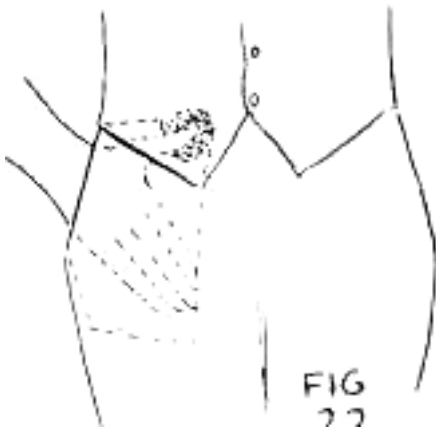


Figure 22.

Remove right hand and show both sides, fingers wide apart.

"But will it stay there? No."

Reach in and turn pocket inside out, leaving it out.

"It walks over into my left pocket."

Show left hand, both sides, fingers wide apart. Reach in and remove handkerchief. Turn left pocket wrong side out and show silk freely.

Turn both pockets in again. As right one goes in, push right thumb into upper corner and bring silk down into pocket as before.

"Now watch. I shall place it back in my left pocket."

Place red silk in left hand back in left pocket as you did the silk in right pocket. Tuck it into upper inner corner with thumb and move fingers about lower down in pocket. Remove hand and show it empty.

"But just because I placed it there, it will not stay."

Turn left pocket wrong side out and show that silk has gone.

"Now, sir, will you please reach into my right pocket and remove the little wanderer?"

Spectator assisting reaches into pocket and withdraws the silk. Turn pocket inside out. Now push both pockets in again, and as you do so, pull silk in left pocket down lower in pocket.

"I wonder whether you understand this, sir? Suppose we try this experiment again. I just place the silk into my right pocket."

Go through movements again of placing silk in pocket. After it is concealed in upper corner, withdraw hand.

"You are convinced that I placed the silk into my pocket. Now watch."

Turn right pocket out and show empty.

"Please reach into my left pocket yourself."

Turn so that he can readily reach into pocket and remove silk. Then turn left pocket out.

"See, you place the silk in one pocket, and it bobs up in the other."

NOTE:

In all this pocket work, be sure that your coat is held back so that audience can readily see that silk really goes in and out of trousers' pockets. You must make the experiment convincing.

"Now, I shall ask you, sir, to tie a knot in the silk—one in the middle of the handkerchief."

Assistant ties knot in handkerchief. Take it from him and hold it in your left hand so that audience can see knot. Turn right pocket in, pulling silk in upper corner down into lower part of pocket.

"You have tied a knot in the silk. Again I place it into my pocket."

Place silk in right pocket, pushing it into upper corner as before. Remove hand.

"Do you believe in spirits? No? Then please reach into my pocket when I say THREE and remove the silk."

Turn right side to audience and hold coat back with right hand.

"One-two-three."

Spectator reaches into pocket and brings out silk, which is untied, from lower part of pocket.

As assistant reaches for pocket and attention of audience is MISDIRECTED to him, reach into your left back pocket with left hand and remove the blue silk from it. Push into left pocket, tucking it into upper inner corner. Remove left hand. Your left pocket has been turned out so that even if some mem-

bers of audience see you put your hand in your pocket, they will interpret it as merely a move to push your left pocket in again.

"It will not stay tied, you see. It has freed itself from all entanglements."

Turn both pockets out again and show empty.

"A peculiar silk, you must admit."

Turn right pocket in.

"Now I shall ask you to stand at my left for a moment as it will be a bit handier for you."

Place assistant at your left.

"Watch me again. Here are my hands and here my pocket."

Show hands freely. Then tuck left pocket back into place, bringing blue silk down into lower part of pocket from the corner. Remove hand.

"Again I take the little fellow--this little red silk--and place him in my pocket."

Crush the handkerchief up and place in left pocket. Push up into corner, but call attention to movement of fingers in lower part.

"I shall ask you to blow in the direction of my pocket twice."

Blow once to show him how. Then he blows twice.

"You saw the red silk go in--now take it out."

Turn left pocket well toward him so that audience can see. He reaches into pocket and removes the blue silk. THIS IS A GOOD CLIMAX.

Turn left pocket out again to show empty, then replace it. Look at spectator and say:

"You BLUE (blew) the handkerchief, all right."

NOTE:

If you should happen to use a green silk instead of a blue one, say "That's his Irish coming out. He thought you were blowing an Irish tune."

Take handkerchief from spectator.

"Which, after all, goes to show that the silk worm may not know what he spinneth."

NOTE:

Two gentlemen can assist you, if desired, instead of one. Have one at your left and other at right.

* * * * *

THE SILK AND THE FLAME

This is another pretty experiment which has been handed down from the days gone by and will, no doubt, be popular for many years to come.

EFFECT:

A candle, resting in a candlestick, is lighted. Magician reaches into the flame and produces a bright-colored silk handkerchief from it. The candle is then removed from the candlestick and is wrapped in a piece of newspaper. This is given to a boy assistant to hold. Performer rubs the handkerchief in his hands, and it mysteriously vanishes. He tears the paper parcel in half now and, instead of the candle, takes out the missing handkerchief. The last surprise comes when he removes the burning candle from his inner coat pocket.

PARAPHERNALIA:

1--A candle, about 3/4 of an inch in diameter and eight inches long. Just ordinary white candles which fit ordinary candlesticks may be used.

2--Two extra candles.

3--A sheet of highly-enameled book paper, such as is used in printing. Any printer or good paper house can supply you with this. You may use white, India tint, or any light color.

4--A candlestick.

5--A small box of matches. Also a few matches which can be ignited on anything.

6--Two silk handkerchiefs, alike.

7--A handkerchief pull on elastic. (Furnished you Free.)

8--A piece of sandpaper, 2 x 3 1/2 inches.

9--A piece of newspaper, about 18 inches square.

HOW TO CONSTRUCT THE APPARATUS:

The Candle:

Cover one of the candles with the enameled paper. Merely wrap the paper around the candle and glue down the edge. Do this carefully so that paper is smooth and looks like a real candle from a short distance.

Cut away upper wick of candle and insert a match into candle to imitate wick, head of match up. Make hole in candle with a red hot hairpin or with sharp instrument so you can easily insert match. Match should protrude from candle about half an inch.

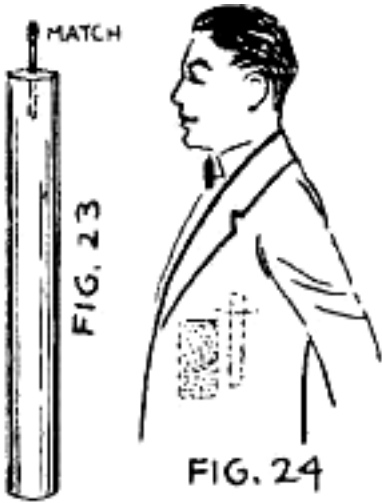


Figure 23.

Inside of your coat at upper left side, sew a special pocket. This should hold candle easily but should be not quite as deep as the candle is long. In front of this pocket in coat, sew the piece of sandpaper with rough side exposed. If you prefer, you may just pin this on, but be sure it is secure.

Figure 24.

The Candle Shell:

Take another candle and wrap enameled paper around it as you did with the first. Slip this paper shell from the candle. The shell must be the same length as the candle. Now take two pieces of candle about an inch long. Place one piece with a good wick on it in the top of the shell. Take a silk handkerchief and push it into the shell. Then insert the other piece of candle in the bottom, pushing it up flush with edge of shell. This shell should look just like candle in your inside coat pocket.

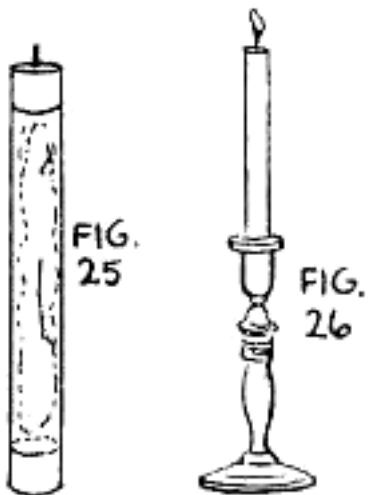


Figure 25.

Place candle in candlestick.

Figure 26.

NOTE:

The covered candle and candle shell may be made to look like the expensive fancy candles on the market. A little ingenuity on your part—and you can build a pretty effect.

Match Box Arrangement:

Take the small box of matches. Push box open about two-thirds of the length. Take the second silk, just like the one you placed in the candle shell. Fold it or crush it and wrap the end of handkerchief around it to make a parcel. Place this inside the cover of the match box. Push it in so that it will be held securely out of sight.

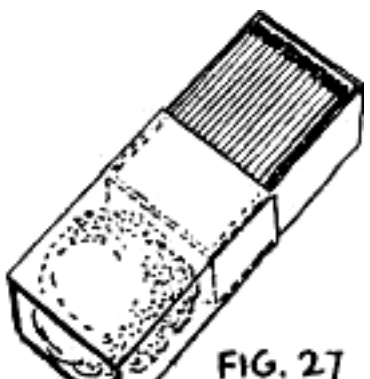


Figure 27.

The Handkerchief Pull:

This is for vanishing the handkerchief later on in the experiment. Sew a small ring under bottom edge of vest, just back of your hip, about an inch back of side seam. The pull is pear-shaped with an elastic attached. The elastic may be from 12 to 18 inches in length. Experience will teach you the length best suited to your needs. Run the elastic through the lower side of ring and up to center back of vest on the under side. Secure it with a safety pin at the point where the end of elastic reaches.



Figure 28.

Elastic should hold the Pull just under the ring without any undue stretch of elastic. When Pull is pulled out from body a foot or so and then released, it will fly back into position.

To make it easy to get at Pull when you need it, place it in lower right vest pocket. Some performers carry it in that pocket throughout their show, while others arrange it just before performing this trick. If you need this pocket for other experiments, do not put the Pull in it until just before this trick. You will have no difficulty in doing so when you have left side turned to audience.

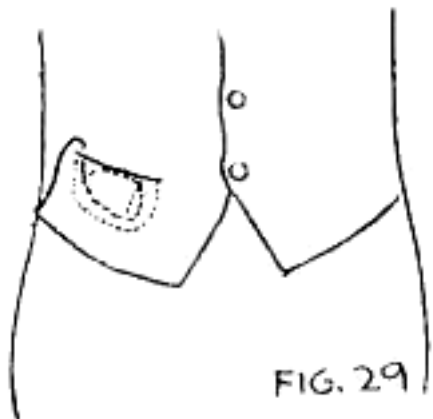


Figure 29.

SECRET AND PATTERN:

To Prepare:

Have candle shell in candlestick on table. Place box of matches with silk inside near candlestick. Place the piece of newspaper nearby. Pull is in lower right vest pocket. Place real candle with match wick in special inner coat pocket with the piece of sandpaper attached in front of pocket.

To Perform:

This experiment may be performed without assistance, but it is well to have an assistant. Have a little girl come up from audience. Place her a little in front of you and toward your right so that she does not screen your movements from audience.

To girl:

"If you will watch me closely, I will show you the mystery of 'The Silk and the Flame.' It is taken from the story of a fairy magician who one evening gathered his little friends together by the candlelight."



Pick up box of matches with left hand and take out match with right. Strike match and light fake candle in candlestick. Hold match box in left hand as in Figure 30.

Now place right hand over box and close box with left hand, forcing the silk out of box into palm of right hand.

Figure 31.

Curl right fingers around silk and keep back of right hand to audience.

Replace match-box on table.

"When they were all assembled, he reached over the flame to warm his fingers for a moment."

Move left hand over the flame. Close hand and then open as though you thought you might have something in it. Do this slowly and gracefully so that audience will be interested in watching your movements. Then move right hand over the flame.

"Suddenly he dipped his hand into the flame."

Dip right hand close to flame and move up again.

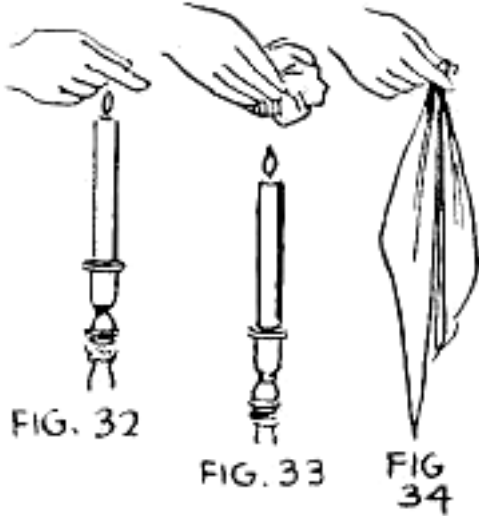


Figure 32.

Uncurl fingers a little and allow silk ball to expand.

Figure 33.

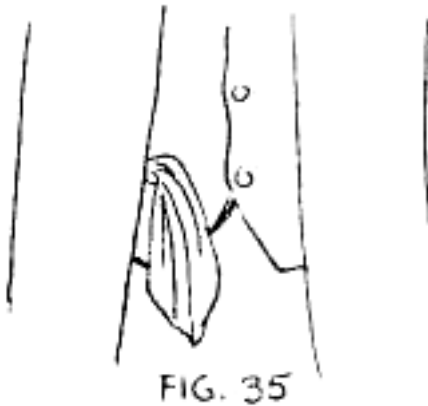
Finally move hand a little to side and above candle and allow silk to hang from finger-tips.

Figure 34.

"And behold, he produced a brightly colored piece of silk --just as though he grasped a beautiful butterfly that was hovering around the flame."

Spread silk out and show to audience and assistant.

"This, Mary, is magic silk made from the flame."



Place silk in lower right vest pocket. As you do this, tuck a little of it into the opening of the Pull.

Figure 35.

"Then the fairy magician picked up the candle. He struck on the table three times with it--that's a magic number."

Take candle from candlestick. Strike bottom of it three times on table, without putting out flame. This is to show that candle is solid without saying so.

"He wrapped it up in a magical newspaper. Many fairy tales in this one."

Wrap candle in the newspaper. Do not stop to extinguish the flame. As you cover candle, flame will go out. Twist the ends of the paper.

"He twisted the ends. And then he gave it to one of the little fairy princesses to hold. How would you like to be a fairy princess?"

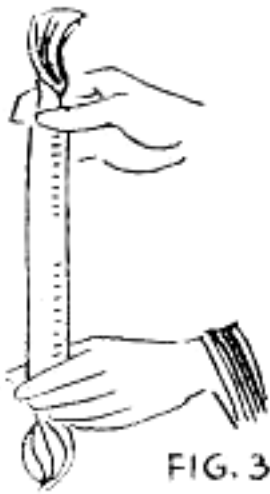


FIG. 36

Give wrapped fake candle to little girl assistant. Hold it at each end where solid parts of candle are. Have girl hold it the same way so that she can feel the solid candle.

Figure 36.

"You feel the candle all right, don't you? Just hold on tight."

Reach into right vest pocket with right hand. Take out silk and pull together. To do this, insert tip of forefinger into opening of "pull" and remove it from pocket with the silk. Hold "pull" against right palm with back of right hand to audience. It is easy to conceal it in this way.



FIG. 37

Figure 37.

"Now he stroked the magic silk gently."

Take silk in left hand, removing first finger from opening in "pull." Hold "pull" in right palm with third and fourth fingers curled over it.



FIG 38

Figure 38.

Some performers palm the "pull" as in Figure 39.



FIG. 39

Stroke silk twice with thumb and first two fingers of right hand.

"He tucked it into his! hands."



FIG 40

With fingers of left hand, work silk into the "pull" in right hand. Grasp it first by the center. About four movements should be enough to conceal silk in "pull."

Figure 40.

"Then he held it in his left hand."

Pretend to place silk in left hand. Make movement of putting it from right into left hand. Close left hand as though grasping it. Look at left hand to MISDIRECT attention from right.



FIG. 41

Figure 41.

During this time, bring right hand back toward body and release the Full. It will fly back with silk in it, under coat and into position under ring.

NOTE:

In using "pull," be sure that your right forearm screens elastic. Also be careful that there are no objects in any of your pockets against which "pull" might strike and make a noise. Bringing right hand back toward body before releasing "pull" helps to keep it from making an unnecessary bang.

"But look! He opened his fingers and the silk had mysteriously disappeared."

Open both hands slowly and gracefully and show them empty.

Figure 42.

"Mary, have you still the candle? You have."



Take parcel from her. Tear it open at center and remove the silk.

Figure 43.

"And strangely, when the fairy magician touched the parcel, the candle, too, had disappeared--and in its place, was the magic silk."

When you have removed silk, crush the newspaper and fake candle into a small ball and place it on table.

"The fairy folk all wondered what had become of the candle. It occurred to the fairy magician to look in his inside pocket."

Reach into inside coat pocket. Take out the candle, and, as you do so, quickly strike the match end on the sandpaper. Remove candle with wick lighted.

"And there, resting peacefully, was the candle, light and all."

Place lighted candle in the candlestick.

NOTE:

In making up the match ends for the candles, some magicians like to use wax matches. These are imported from Italy. You can buy them at some of the large department stores. Ordinary modern ones, however, answer the purpose very nicely.

* * * * *

THE CANDLE. THE SILK, AND THE PAPER TUBE

Another version of the preceding effect.

EFFECT:

Performer produces a silk from the flame of the candle and tucks part of it into his vest pocket. He then covers candle with a tube which does not completely conceal it. The top is still seen, lighted. Magician then removes candle from tube and wraps it in a piece of paper. Suddenly the silk handkerchief vanishes from his pocket. He tears open the wrapped

candle, and there is the silk instead of the candle. He removes the tube from the candlestick and, to everyone's astonishment, there is the candle in the candlestick.

PARAPHERNALIA:

Similar to that used in the preceding experiment.

HOW TO CONSTRUCT APPARATUS:

Cover a candle with India tinted enamel paper.

Around this wrap another piece of the same paper and glue the edge down. Make this so that you can slip it off to make a candle shell. Into this shell, insert a small piece of candle with a wick. This forms the top of shell. Push a silk tight up against piece of candle.

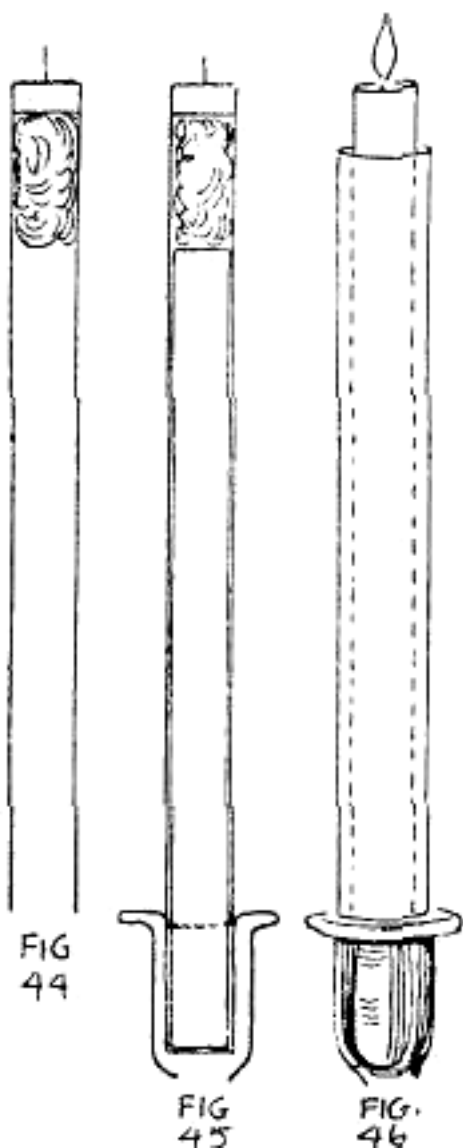


Figure 44.

Burn wicks a little of both solid candle and the fake.

Now slip shell down over solid candle and place both in the candlestick. Bottom edge of shell should come just a little inside of candlestick so that audience cannot see it.

Figure 45.

To audience, the faked candle looks like an ordinary candle.

Now make a tube out of paper or cardboard. This must fit easily over candle and shell and rest on candlestick, showing about half an inch of candle above it.

Figure 46.

SECRET AND PATTERN:

To Perform:

Have candle and shell set in candlestick.

Have tube nearby on table.

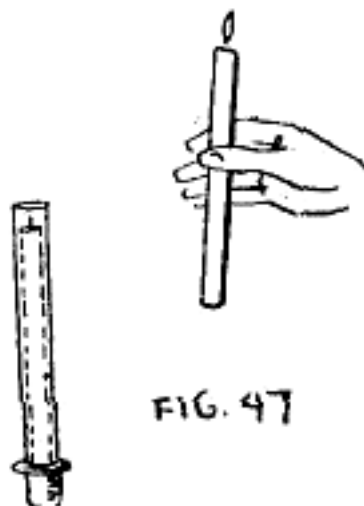
Have match-box with silk in it also on table.

Light candle and produce silk from flame as taught to you in preceding effect of this lesson.

Show tube empty and place it over candle. Shell extends above it so that you will have no difficulty in grasping it. Remove shell, leaving solid candle concealed in tube.

Be careful not to expose open bottom of shell to audience.

Figure 47.



Wrap shell in piece of newspaper.

Vanish silk in the "pull." Tear open paper parcel, containing faked candle, and produce the silk in place of the candle.

Lift tube from candlestick and show that candle has returned to its original place in the candlestick.

Lift candle out of candlestick and show it to audience. Then drop it back into candlestick.

* * * * *

THE EDUCATED KNOT

A clever experiment to perform on the stage or in a place where you are a little distance from audience.

EFFECT:

Magician ties a knot in the middle of a silk handkerchief. He holds the handkerchief up by one corner, and before the very eyes of his spectators, causes the silk slowly to untie itself.

PARAPHERNALIA:

1--A silk handkerchief.

You may use one of the silks sent to you with your paraphernalia. For stage use, however, it is well to use a much larger silk. A silk pocket handkerchief is suitable.

2--Fine black silk thread.

3--A small black button.

SECRET AND PATTERN:

To Prepare:

Sew one end of thread to one corner of handkerchief. Tie single knot in handkerchief, letting thread follow knot. Hold handkerchief out in front of you at about your waistline. Let thread hang down to floor. Allow one inch beyond point where thread touches floor. Cut it off there and sew small black button or small piece of cardboard to this end. Untie handkerchief.

Figure 48.

Another arrangement is to have a staple driven into the floor. End of thread can be run through staple and off stage to an assistant, who pulls thread at proper moment.

(28-18)



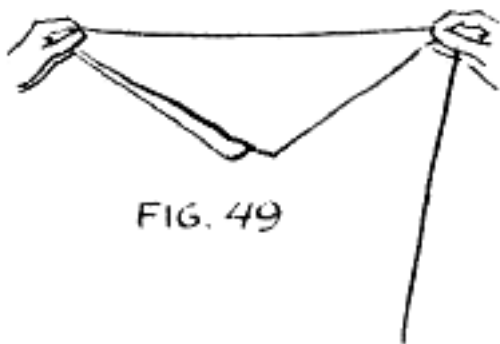


FIG. 49

To Perform: Method No. 1.--Hold handkerchief as in Figure 49. Corner with thread attached is in left hand. Thread is not visible to audience. This view is toward the audience.

Bring corners in each hand together and tie a loose single knot. Right corner comes over into left hand. Left corner with thread following it goes over to right hand.



FIG 50

Hold handkerchief up by free corner in left hand. The thread goes up over top of knot.

Figure 50.

Hold handkerchief out in front of you. Let thread fall to floor. Place right foot on button attached to thread, and stretch thread taut.



FIG 51

Figure 51.

Method No. 2.--If you are using an assistant and have the staple arrangement, have your table a little in back or to the side of the staple in the floor. Pick up the handkerchief from the table, tie the knot, and hold it in front of you, standing just back of the staple.

Figure 52.

Have assistant pull thread at proper moment to untie the handkerchief.

If you are working by Method 1, just raise your left hand higher and higher. The thread pulls up the bottom corner of handkerchief through the knot and unties it.

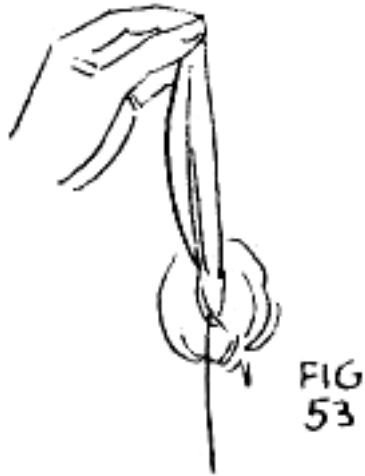
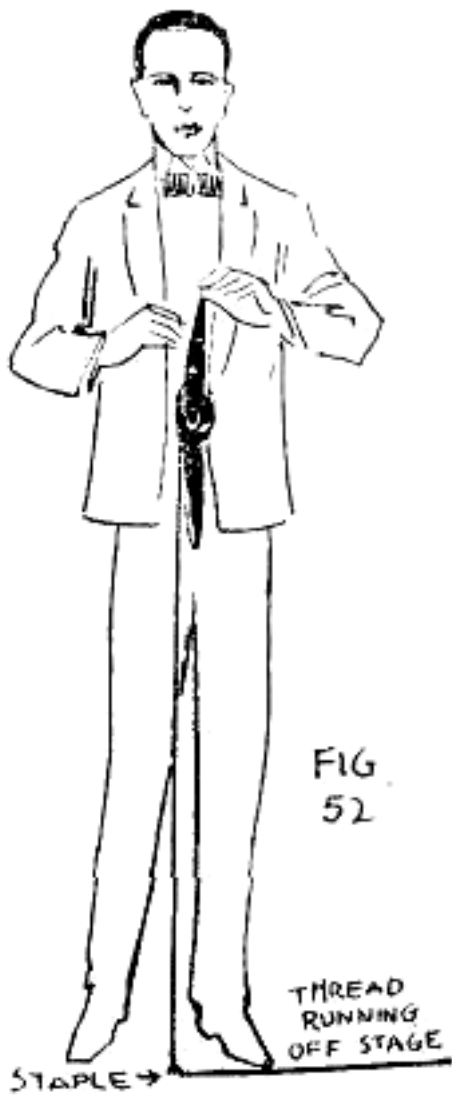


Figure 53.

(28-19)



FIG
54

It then hangs straight again from left hand. The thread coming from bottom corner cannot be seen by audience.

Figure 54.

Perform this slowly, and the audience is amazed to see the handkerchief slowly untie itself before their very eyes.



FIG. 55

Method No. 3.--A third way of working this experiment is to have end of thread attached to vest button. Make handkerchief untie by pushing down on thread with wand or right hand.

Harlan Tarbell

TARBELL SYSTEM, INCORPORATED, Chicago.

LESSON 29

So-called Mind Reading and Mental Experiments have a tremendous effect over an audience. The Magician accomplishes things which to the spectators seem nothing short of miracles. It is to your advantage, then, to have several of these effects in your repertoire. Many Magicians specialize in this type of Magic entirely.

In this lesson I teach you three excellent Mental Effects:

1. The Chess Knight's Tour. A Chess problem done with a blackboard or large card which has been chalked into squares. The Chess Knight moves in regular chess fashion to cover every square, starting with any number which audience calls out. This is a good example of supposed supermentality.
2. A Mind Reading Act. Audience writes questions, dates, numbers, descriptions of anything on pieces of paper. Each one folds his paper and places it in his pocket. Yet the performer knows what has been written and proceeds to answer questions and give numbers, etc. You have been amazed yourself to see Magicians do mind reading like this. Now you can learn this wonderful feat.
3. Telepathic Drawings. Spectator draws a picture on a sheet of paper, folds it, and hides it in his pocket. Performer does not see paper. Yet he reproduces the picture on a piece of cardboard, seemingly getting the message of the picture by mental telepathy.

DIVISIONS OF MODERN MAGIC

Modern Magic has evolved until now it may be classified into three major divisions with regard to its effect on the audience:

1--Effects which are accomplished by mere physical means. Tricks with cards, coins, handkerchiefs, etc. - things usually employed in a magical performance. In this division are effects which people believe they could do themselves if they could discover the "Modus Operandi." But you know, of course, that they seldom discover the clever magical principles. You have already learned many puzzling experiments which come under this division.

2--Experiments based on Super-Mentality. In this division are included mind reading, mental telepathy, and all effects apparently based on remarkable mentality. To Magicians these effects are no more mysterious than a simple card trick, but to the audience they are manifestations of unusual mental power on the part of the performer. The spectators think that they could not possibly accomplish these results. I am making two classifications of Mental and Psychic effects, although in some cases they really overlap. I place the effects in today's lesson in the second division. Some of them, however, really border on the psychic.

3--Effects which seem to be accomplished only by supernatural psychic power. Reading sealed messages, slate writing, table tipping, invisible communication, ghostly materialization, trumpet talking, bell ringing, jangling of tambourines -- all come under this division. To the audience these effects and illusions seem like miracles, and a great mass of people really believe the performer is in communication with the spirit world and is aided by spirits in accomplishing his effects.

Marvellous effects which come under this division are taught to you later in the Course.

UNLIMITED OPPORTUNITIES IN MAGIC

The field of Magic is so varied and so broad that its opportunities are limitless. In the three great divisions of the art, described above, there is no end to effects, experiments, illusions of all sorts. You can keep on developing and growing with Magic indefinitely. And your progress is, of course, commensurate with the earnestness which you put into your study and work. There are performers who do general magic, and there are those who specialize. Both have a wide scope, and for both there is BIG MONEY to be made.

SPECIALIZATION

Specialize if you will after you have gained a knowledge of the general field of Magic. Each performer has his own likes and dislikes. Certain types of performers are better adapted to work along certain lines than others. Some take to comedy magic, some to mental feats, and others to psychic effects. Some specialize in manipulation until they are master Sleight of Hand artists, others become Illusionists. So, you see, there is no end to what you can do in Magic.

You can capitalize on your own likes and special abilities. But be sure that you make yourself an artist in your specialization. Don't think that merely because you have an act that is a little different and composed of wonderful effects that you can sit back and let the act do itself.

PRESENTATION

The important thing is presentation. Any really great Magician will tell you that it isn't so much what you do as how you do it. You may have \$50,000 worth of magical apparatus and be a failure financially as a Magician. Then again you may have a few dollars' worth of paraphernalia and be a HUGE SUCCESS, financially and every other way.

Remember, an effect is only as good as its presentation. That is why I lay such stress on the Scientific aspect of Magic --on the Principles, the Psychology, Showmanship. While the actual trick is important, the little things that put it over are just as important. The trick is as nothing without the proper Presentation. Take an elaborate illusion--present it in a slipshod, uninteresting manner -- and you make it ridiculous. But inversely, take the simplest impromptu trick -- present it with finished Showmanship -- and you make of it a classic.

I want you to realize the close connection between Psychology and Magic. The more you study Psychology, the better will your Magic be. The discussions which I have given you on it are invaluable to you. Give them a great deal of thought. Not only will this study make you a better performer, but it will also make you a bigger public attraction. Study the reactions and impressions of your audience. Study the things that make them talk about you afterward. Study the creating of interest in them. Your reward will be packed houses when you play. Managers will come to know you as a big "box office attraction." And, of course, with this will come real money.

CREATING OF EFFECTS

At this stage, you should be able to begin creating effects. I have no doubt but that you are getting ideas right along on which to build new experiments. Work on these ideas. Perfect them. You will find it tremendously fascinating. Then just think how wonderful it will be for you to come out and present absolutely new and original effects which you have created yourself.

Today, as always in the past, effects accomplished by super-mentality, super-natural, or psychic power have a tremendous fascination for an audience. People flock to the performances of those who "see all and know all." They bring their troubles, their problems to be solved by the magician, so great is his power. As an example of this, the story is told of the Davenport Brothers, magicians of days gone by. It is said that when they performed as ordinary tricksters, their pocketbooks were thin; but when they claimed that their effects were produced by super-natural power, people began to be interested in them.

Fraudulent Mediums Fleece the Public

So great is the psychic appeal that fortune tellers, spiritualists, mind readers, clairvoyants, have all thrived on a deluded public. A smooth tongue, salesmanship, showmanship, work on the imaginative mind; and all these have served to fill the pocketbooks of many who have deceived the people with a pretense of psychic power.

The modern magician stands opposed to serious deception through the claim of supernatural power. The late Houdini fought hard against the "fraudulent mediums" preying on the people. His quarrel was with those who fleeced the public of thousands of dollars under the pretext of having psychic power. He brought out into the open their dark and secret means for deception and showed these to be nothing but mere magical tricks.

Magician Does His Psychic Tricks in the Spirit of an Entertainer

The magician of today mystifies the public, plays tricks on them, and fools them; but he does it in the spirit of an entertainer, not as a serious spiritualist. Because of his seemingly miraculous feats and his clever presentation, the public often believes that he has unusual intellectual and mental power and is a master of difficult and unusual situations. The imaginations of the people build this power around him and that is what makes him the "box office attraction."

In the case of Houdini, for instance, in spite of the fact that he lectured against and exposed the fraudulent spiritualists, and in spite of the fact that he stated expressly that he possessed no supernatural power, he could not convince many people that he was not aided by psychic forces in the marvellous experiments which he performed. There are thousands of people also who after seeing Thurston's wonderful spirit cabinet presentation, swear that Thurston must be aided by spirit forms. They cannot account for such peculiar happenings in any other way.

Through the cleverness of the magician, he produces effects which seem to be based on supernatural and psychic power. The important point, however, is that his presentation is such as to make his deception legitimate for it is done merely in the spirit of entertaining the public.

Mental and Psychic Effects Based on Imagination of Public

The magician accomplishes his apparently marvellous feats of a super-mental and psychic nature merely by playing on the imagination of the public which attributes such powers to him. The human imagination is such an elastic thing. It adjusts itself to almost any

situation. The magician then can work on this imagination. He can answer questions in a broad and general way and let the people carry them out in their own minds to a satisfactory conclusion. Actually, the mind reader gives very little information of importance. What he says is information is really imparted to him by the people themselves or something that covers any case in a general way. The people then interpret this to suit their individual needs.

When you are behind the scenes, everything has a different aspect. You learn that the mind-reading, the slate-writing, the message-reading, and the so-called psychic phenomena are based only on a scientific foundation which is a regular part of your training as a Magician. You see that everything is based on natural law and that you give things their seemingly supernatural power only by the proper clothing with Suggestion, Showmanship, Dramatic Atmosphere, and Patter.

All this you do to bring in the box office receipts and to create a lasting impression of your ability as a performer with the audience. Your supposed psychic power lies only in the imagination of the public. And you use it only for temporary effect and not for illegitimate gain.

In your programs it is wise to maintain a good proportion between physical, mental, and psychic effects. It gives enough variety and interest to keep the audience in your power. The proportion depends on the characteristics and personality of the performer and on the requirements of the occasion.

LESSON 29

In this lesson I give you interesting material that you can use in putting on acts that demonstrate your seemingly marvellous mental and psychic powers.

THE CHESS KNIGHT'S TOUR

While few people in the average audience know how to play chess, most people know enough about it to get the impression that it is complicated. It is not necessary that your audience know anything about the game to appreciate this effect. You sell them the idea of the difficulty of accomplishing the experiment in your Patter.

EFFECT:

Performer has a blackboard on which are chalked off 64 small squares, each numbered. A spectator is asked to select any one of the numbers. The Magician then starts with that number to make his Chess Knight's Tour of the board. The problem which he solves is this: to move the Knight, starting at any point on the board, two squares at a time -- and thus to cover every square in 64 moves, ending up at the starting point.

PARAPHERNALIA:

1--A large blackboard ruled off into 64 squares. It is well to make the lines and the numbers with white paint so that they will not wash or rub off and board can be used permanently. If desired, this board can be made to fold up. It can be made of three or four pieces hinged together which fold down flat like a folding parlor screen. You can also secure a blackboard made of prepared cloth, and this can be rolled up. Some school supply companies sell these. The size of the board must be governed by the conditions under which you are performing. Be sure that it is large enough and that the numbers are plain enough to be seen by everyone in the audience.

Figure 1.

1	2	3	4	5	6	7	8
9	10	11	12	13	14	15	16
17	18	19	20	21	22	23	24
25	26	27	28	29	30	31	32
33	34	35	36	37	38	39	40
41	42	43	44	45	46	47	48
49	50	51	52	53	54	55	56
57	58	59	60	61	62	63	64

FIG. 1

2--Chalk.

3--Folding easel to support board.

4--Special card for routine of numbers.

SECRET AND PATTERN:

To Prepare:

Some performers accomplish this effect from memory, and you can do the same if you take the time to memorize the number routine. Many of you, however, will want to add the effect to your programs at times and will not want to bother to memorize the numbers.

One method of doing it is to have the numbers written in order on a card. This card is placed in the chalk tray at the bottom of blackboard on easel. It can be read at a glance when you look down at it quickly.

This card may also be placed in vest pocket. Under cover of body, it can be removed and palmed in left hand.

If you do not have an easel and tray, you may place chalk and card on a chair or small table nearby.

Another method to use is to write the number of the next move in the corner of each square - very small so that it can be read only at close quarters. Do this with a lead pencil. A code system of lines and dots may be used to represent the numbers. By this method, even close scrutiny of the board may be permitted. Ordinarily, however, the board is not examined and regular numbers may be used.

Here is a good code to use:

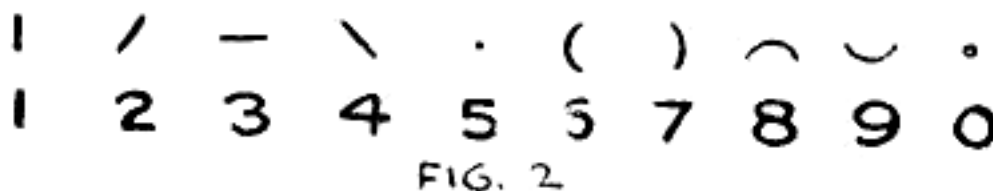
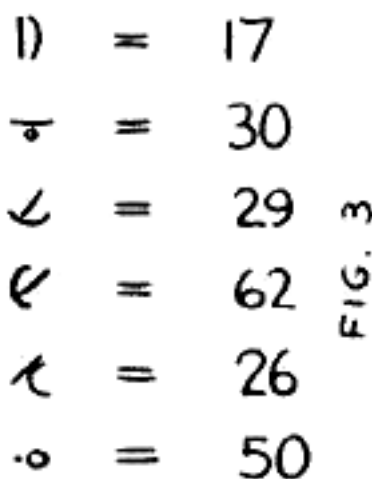


Figure 3 shows the application of the code. To make numbers of two figures, merely combine the signs for each of the individual figures. Thus, the code for 17 would be the sign for 1 with the sign for 7 right next to it.



THE NUMBER ROUTINE:

1, 11, 5, 20, 37, 27, 44, 29, 35, 50, 33, 43, 58, 41, 26, 9, 3, 13, 23, 8, 14, 4, 10, 25, 19, 2, 17, 34, 49, 59, 53, 47, 64, 54, 60, 45, 28, 38, 21, 36, 30, 15, 32, 22, 7, 24, 39, 56, 62, 52, 42, 57, 51, 61, 55, 40, 46, 63, 48, 31, 16, 6, 12, 18,--

Then after 18, comes the number 1 to make the 64th move. Regardless of what number you start with, you continue from that number in the order of the routine given here -- then you go back to number 1 and continue through the routine until you reach the number you started with. For instance, if you start with 50 -- you move to 33, then 43, and so on through 18, then back to 1 and through 35 to 50 again.

To perform: Have blackboard with numbered squares and little cue numbers in the corners ready.

"Ladies and gentlemen: In presenting the Chess Knight's Tour, I am bringing to you a feat coming under the classification of super-mental problems. You who play chess and know the peculiar move of the Chess Knight (which is the piece with the horse's head) can appreciate the difficulty of the Tour which I am about to present. To those of my audience who do not understand the game of chess, let me offer a few words of explanation.

"On this blackboard I have 64 squares drawn to represent the squares on the chess board. The chess board and checker board are the same with red and black squares and no visible numbers. For convenience in demonstrating the Tour, however, I have had these squares numbered from one to sixty-four.

"In chess, the Chess Knight does most of the capturing of the opponent's men. This Knight has a peculiar move which it is difficult to explain in words. Wherever on the board the Knight happens to be, it can be moved into any square which is removed from it by two squares not in the same direction. For instance, he could not be moved from number 2 (point to board) over to number 4 or 18 -- but he could be moved through 3 to 12 or through 10 to 19. The final square which he alights on cannot be in the same direction as he is moving, but must be on a slant. Thus, supposing you have moved from 19. The next move would be either back to 2 or to 9, 25, 34, 36, 29, 13, or 4."

As you explain these moves, point to each square with your chalk so that audience will understand them. If you can easily erase them, demonstrate by actually drawing lines through each square as you show moves. Otherwise, just point out squares.

"You will note that the first square into which a move is made is immediately above, below or to the right or left of the starting place. For convenience, let us call the starting square A, the next square passed through B, and the square on which the Knight alights C.

"If we start at number 36, that would be square A. 35, 37, 28, or 44 would be square B. Any number diagonally off these four numbers would be square C. Let us assume that we moved to 37 as square B. Then either 30 or 46 would be square C for Knight to alight on.

"The problem I am going to present is to start the Knight from any square on the board and by a continuous series of sixty-four moves to cause the Knight to alight on each square ONCE and on NO square more than ONCE and to END UP AT THE SQUARE STARTED FROM.

"When you appreciate the peculiar move of the Knight and realize that you have sixty-four places to choose from for his start, you can understand the perplexing problem I have to contend with and the many moves I have to consider.

"Now, I shall ask someone to select one of the 64 numbers from which to start the Chess Knight on his journey.

"The gentlemen here says 29. All right. Here is square 29, just about in the center of the board."



Figure 4.

Point to number 29 and draw a diagonal line through it from the upper left corner to the lower right corner. Look at the cue number which you have marked on this square for your next move -- or if using a card, look at that, but don't allow the audience to see you do it.

"Now I can start by moving through 28, 30, 21, or 37. I shall move through 28 and light on 35."

Point to 28 but do not cross through it. Draw a diagonal line through 35. Then look at cue number in this square. It is 50.

"Then through 43 to 50."

Continue this now through the numbers, one after the other, crossing off the square on which the Knight alights each time. Finally, you will have crossed off number 44, the one before 29.

"And finally, the Knight jumps from number 44 up through 36 and back to the STARTING PLACE -- 29. The Knight has alighted on every number once as you see by the cross lines -- and only once -- and now he is back to 29."

Give a slight bow to bring forth applause.

* * * * *

A MIND READING ACT

This act requires the use of an assistant. In some cases, he is used behind the stage; in other cases, he is used to go through the audience with paper and pencils. Then again when a lady assistant is used, she is often placed on the stage to answer questions while performer goes down through the audience to check up on people wanting information. This act can, however, be presented by the performer alone if he has a few minutes' time between acts.

EFFECT:

Pads of paper and pencils are passed out through the audience, and spectators are requested to write anything they choose on the paper. They may write telephone numbers, addresses, names, questions, or make drawings. Then they are told to tear off the paper, fold it, and place it in their pockets. Performer or assistants at no time touch this paper on which is written the information or question. In spite of this, Magician is able to sit on the stage and tell what spectators have written and to go about answering questions. If a drawing has been made, Magician takes a pad of paper or goes to a blackboard and draws a duplicate.

PARAPHERNALIA:

1--Pads of paper. Get 2 or 3 dozen at a stationery store. A handy one is 3x5 ins. in size and has perforated upper edges so paper can be easily torn off. Upper part of pad above perforation is stapled together, which facilitates working.

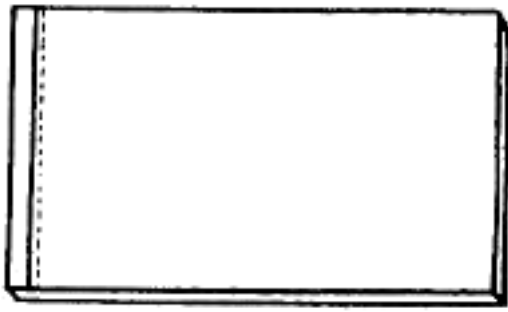


Figure 5.

The number of pads you require you can best determine for yourself by the size of your audience and your speed of working.

(29-8)

FIG. 5

2--Hard lead pencils--Number 4 is suitable.

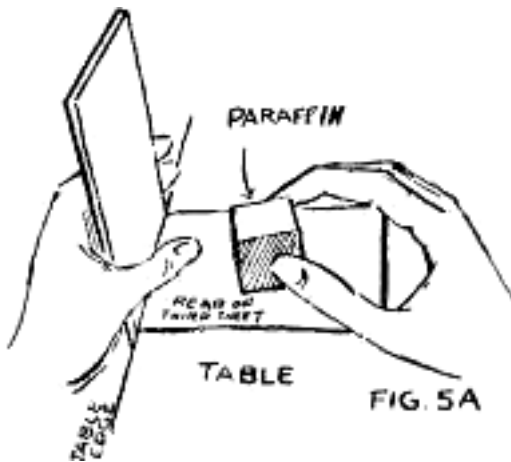
3--White wax, paraffin, or a white candle.

4--A small box of lamp-black. This can be purchased at a paint store or drug store.

5--Some cotton, or a powder puff.

6--A tablet of paper--8 1/2 x 11 inches.

SECRET AND PATTERN:



To Prepare:

Take the tablets of white paper and on the under side of the third sheet down from top, rub over it the white wax or paraffin. Be careful to cover all parts of the sheet except near the edges. It is easiest done by opening pad between third and fourth sheet and placing pad at edge of table with first three sheets on table. Sheet can be easily waxed without musing.

Fig. 5A.

Do not remove the paper from tablet or pad to do this. If you do it properly, a spectator can run through the pad without detecting any special preparation. The surface of the under side of the third sheet is slightly waxy in texture, but not enough to make it noticeable to spectator. This waxed surface acts as a carbon paper--a white carbon paper.

If you take a hard lead pencil and write something on the first or second sheet of the pad, you will find that the wax will cause an imprint on the upper side of the fourth sheet of what was written. You cannot see it, but it can be brought out by a developing process. Take a bit of cotton, or a powder puff, dip it in the powdered lamp-black and daub lightly on the paper. The lamp-black will adhere to the waxy part on the fourth page. It is then easy to read what has been written.

So you see, you need not have the actual slips on which spectators wrote. You merely collect pads and pencils and then BEHIND THE SCENES develop the fourth pages of the pads. Thus you bring out what was written.

The audience is so much interested in holding on to their written slips that they are not suspicious of the pads. These are casually collected to get them out of the way and then taken back stage.

Hard pencils are used and are furnished to spectators so that they will have to bear down harder in order to write and thus will make the imprint clearer.

To Perform:

Have pads and pencils on table at side of stage or come forward with them in your hands.

You have this writing done early in the performance so that you will have plenty of time to do the developing. Some performers do this at the beginning of their evening's performance, others at the beginning of their mind reading act. Then they do special stunts, like the Chess Knight's Tour, the Yogi's Prediction, X-Ray Cards, or some other stunts to give assistant time to develop the writing.

As you do not have to answer all the questions or tell what everyone wrote, it is sufficient to develop fifteen or twenty slips of paper. Of course, if there is extra time and you think you might get something especially good to answer, more than this may be developed.

Start your work in this way:

"Ladies and gentlemen: Perhaps never in the history of the world have people been so interested in mental communication. telepathic problems, and the occult and psychic as they are today. Recent discoveries and experiences are bringing forth phenomena that have invited careful investigation. With the development of radio and the traveling of vibrations over such great distances—things which have been developed mechanically—one wonders what could be accomplished by such a wonderfully attuned organism as the human brain with its marvellous mental power.

"If people had been told a hundred years ago that without any visible speaking connection it would be possible to listen to a program of music in New York City while in Chicago, they would have regarded the idea as the conception of a crazy man. Just so it is with everything new that is brought forth. What is difficult today, we will understand easily tomorrow. Many of us have had presentiments and hunches that amaze us when we learn how accurate they were. We may sit in Chicago and suddenly feel that there is a big fire in St. Louis, and then pick up a paper the next day and find it to be true.

"How far human thought vibrations travel, we do not know. But if radio vibrations travel, why shouldn't thought? What I am about to present is not due to supernatural power. It is but the working of scientific law. I have developed certain senses in such a way as to understand certain conditions that the ordinary person misses. All of us have this power but all do not know the proper way to use it. As I stand here now, I can sense a number of thoughts—some stronger than others. Some people's thoughts are easy to get vibrations from, others are difficult. And with so many vibrations coming from an audience at the same time, there is often a confusion like you get from a number of stations together on the radio.

"In order that you may concentrate on certain thoughts, I am going to have you write those thoughts on a piece of paper. The writing itself is not important, but seeing a thing written or drawn impresses it on your mind and so makes the vibrations from your mind stronger.

"For your convenience, I shall pass paper and pencils out to you. You may write anything you would like to have me tell you. Perhaps you have some problem you would like to have me help you with. Write any question you choose—but not foolish questions, of course. Or write your telephone number, a date on a coin, a number on a bill, name of a watch your name and address, or draw a picture—any kind of picture or symbol, perhaps a square or a star. Just write anything that comes into your mind. If you prefer you may use your own paper and pencils. The main idea is to write. Now each one of you take your slip of paper, fold it, and place it in your pocket or hold it hidden in your hand. I do not collect any

of the papers. You write your own messages and keep the paper on which you have written them. I never see them. By the way, write your name on the bottom of your slip of paper so that it will help me to locate you. Please return pad and pencil, for use in my next performance, but keep the slip of paper on which you write your question.

Pass down through the audience and distribute pads and pencils, impressing the audience with the idea that they should write telephone numbers, questions, numbers of bills, etc. Explain to them again to tear off the slip they have written on and keep it. Pass pads and pencils around quickly and keep up a line of Patter.

"One woman said to me, 'What you really do is to watch the top of everybody's pencil as they write and see what they have written that way.' Another lady said, 'You slip the papers out of people's hands when they are not looking and read all the papers.' Well, I haven't figured out the pencil method yet by looking at the tops, and you certainly hold those papers too tight for me to get them. Telepathic vibration is easier."

After a number of people have written their questions, collect the pads and pencils and take them back to the stage with you and place them back of the scenes.

If you work with an assistant or two, have them collect the pads and pencils and either come up to the stage with them or go out through the entrance of the theater and return to the stage the back way. The assistant immediately develops the sheets under the white wax carbons by means of the lamp-black or powdered charcoal. Then he takes the tablet, 8 1/2 x 11 ins., and writes on the second, third and fourth sheets of it as many of the questions as possible. He should use a hard pencil. He should copy the information or questions exactly. As a rule, not over twenty slips need be copied.

This tablet is now ready for the performer, and as he begins his mental work on his program, he can readily refer to this writing.

If you collect the pads and pencils yourself, as I told you before, it is well to do this in the early part of the show. You can then step back of the scenes with the pads and leave them with an assistant to develop. You then proceed to entertain the audience with Magic until you are ready for your mental work. Just before beginning the mental work, as you leave the stage for preparation, say,

"Do not forget what you want me to tell you. You have the papers you wrote in your own hands or in your pockets so that you can easily refer to them when I enter into mental work."

If you have the writing done and the pads collected at the beginning of your mental work, you must do something to give assistant time to develop the pads and prepare the special tablet with the information. With two assistants, one can develop and one can write.

NOW, BEFORE WE PROCEED WITH THE MIND READING ACT, I shall give you some interesting experiments to use to fill in the time while assistants are preparing information.

THE YOGI'S PREDICTION

EFFECT:

Performer shows an envelope and a blank card. He says that though he is not a fortune teller, he can often tell how the human mind will think before it does. For instance, he will write a prediction on the card, place it in the envelope, seal the envelope, and have a spectator initial it so that there will be no exchange of envelopes. Magician then asks one spectator to give him a number between one and one hundred thousand, another to name a city, another to call out a color, and still another to name any day of the week. He tears open the envelope, removes the card—and to everyone's amazement, there written on the card are the number, the city, the color, and the day which spectators called out.

PARAPHERNALIA:

1--An ordinary envelope.

2--A piece of red carbon paper. Get the kind of carbon adapted to pencil work.

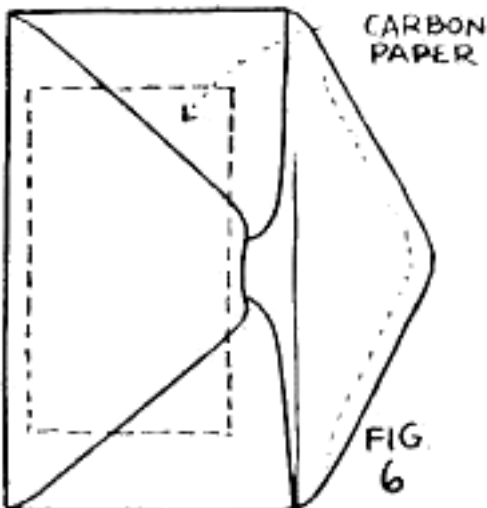
3--A plain card of a size easy to slip into envelope, preferably with soft surface that takes a carbon mark readily.

4--A sheet of white or yellow paper smaller than the envelope.

5--A pencil.

6--A red pencil.

SECRET AND PATTERN:



To prepare: Cut carbon paper down so that it fits into envelope as shown in Figure 6. Have it come to within about one inch from both ends and just below opening of envelope so that when flap is raised it will not be seen. Paste this carbon paper by the corners inside of the front of the envelope. Have the carbon side facing back of envelope so that when card is placed under it in envelope anything written outside will be transferred to card.

Figure 6.

To Perform:

Come forward with envelope thus prepared, with blank card, the piece of white or yellow paper, and pencil. Stand on stairs leading down from stage to audience.

"I am not a fortune teller nor a clairvoyant. I do not see far into the future for you and tell you that you will marry a dark-haired gentleman or a widow with six children. But there are times when I can predict things that a human mind will do in the very next moment. I will work preferably with strangers. First, on this card I am going to write a few words. You will note that it is just a blank card. I will write them in red."

Show both sides of card. Using envelope and yellow paper as a rest, pretend to write down four things on card with the RED pencil. Scan audience as you do so and look straight at four people you will use later on. If you desire, you can have four people stand up for experiment. In reality, you do not make a mark, but you make audience believe that you write a prediction. Be careful of your ANGLE OF VISIBILITY here so that audience cannot see that you are not actually writing. Place red pencil in pocket.

"I have written a prediction. I will now place it in the envelope and seal it."

Open envelope, being careful not to expose carbon. Place the card inside between carbon and back of envelope. Seal envelope.

"Will you, sir, just place your initials on the envelope so that you can identify the envelope later on?"

Give spectator the regular lead pencil and have him initial envelope, then take pencil and envelope from him.

"I want some good spectator to help me. You will do fine, sir. I am a stranger to you, am I not? You have never seen me before. (If playing before a strange audience.) I am going to ask you to give me the first number that comes into your head after I say one--two--three. Any number between one and a hundred thousand. Make it as big as you like or as Complicated as you choose--whether you say 742 or 4, 040 makes no difference. Are you ready? One--two--three. What is the number?"

Let us suppose that spectator says 6, 792. He may call out almost anything.

Hold envelope in left hand with face up. On this place the yellow paper. Take pencil in right hand.

"Just by way of checking up, I'll just write down the number on this piece of paper Six thousand, seven hundred, and ninety-two."

Write this number on the yellow paper. It is transferred through the carbon on to the card inside of the envelope.

"Will you, madam, give me the name of any city that comes to your mind? Any city in the world."

Assume that she says Paris.

"Paris? You must have been thinking of styles for a new dress."

Write down the name, Paris, under the number. This also is transferred to the card.

"Now, sir, how are you on colors? Name any color you happen to think of. Red?"

When a spectator names a color, write it down under the city.

"Now--we have seven days in the week. Which day appeals to you most? Thursday?"

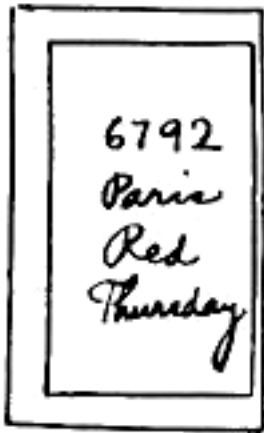


FIG. 7

A fourth spectator names a day of the week, and you write this down under the color.

You now have the four things written on the piece of paper as shown in Figure 7. Inside of the envelope is the white card with the same things written on it, having been transferred through the carbon paper.

"I shall ask the gentleman here to take the piece of paper and hold it so that we can check up. (Read from paper while in spectator's hands.) The gentleman's number-6,792, the city was Paris, the color-red, and the day--Thursday. (To gentleman who initialed envelope.) Do you recognise your initials and writing, sir?"

Show him the envelope. Now tear off end of envelope, being careful to keep above carbon paper so as not to expose it.

Remove the card and show.

"You see that the prediction was correct. I wrote on this card just what the four people called out. Let us check it up. (To gentleman with yellow paper.) The number-6,792, the city--Paris, the color--red and the day--Thursday."

Take paper from gentleman and return to stage. Place card, envelope, and paper on table or in an inner pocket.

NOTE:

Show card freely but do not let spectators scrutinize card too closely and they will not discover that it is a carbon copy of what was written on the paper. Writing with a red pencil and using red carbon is a good stunt. Experiment with it.

THE X-RAY CARDS

EFFECT:

Performer removes deck of cards from case and fans it. He divides it into two equal packets and gives spectator his choice of one. Magician and spectator each hold half of the cards now. Magician holds his cards behind his back, and spectator selects a card from his packet and places it among cards in Magician's hands. Performer turns to audience, holds his packet against his forehead, and tells what card spectator placed in packet. The Magician's packet is kept squared up all the time, and is not fanned.

PARAPHERNALIA:

1--A deck of playing cards.

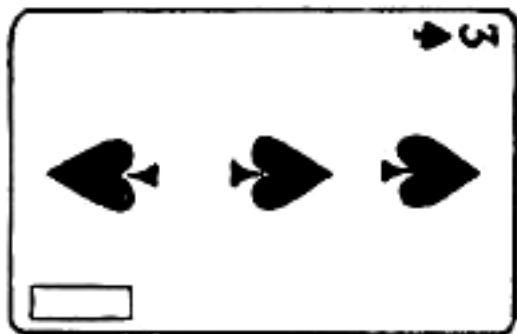


FIG. 8

To Prepare:

Remove the King and Queen of Hearts and the Jack of Diamonds from the deck. Shuffle the deck well and count off 23 cards.

These 23 cards must be specially prepared. Take one card and place it on a board. With a sharp pen-knife, cut out the index number and figure in one corner of the card. Figure 8.

Prepare the other 22 cards in the same way, making all the holes as nearly the same size as possible. Prepare the Queen of Hearts in the same way also.

Place the 23 prepared cards together in a packet with the holes all in line. Then place the Queen of Hearts on the "Bottom" of the packet and the Jack of Diamonds on the "Top."



FIG. 9

INDEX OF CARD SELECTED SHOWS IN OPENING

If any card from the other half of the deck is placed in this packet, except on the top or bottom, it can easily be detected. The index shows plainly through the holes cut in the other cards.

Figure 9.



FIG 10

The prepared part of the cards can easily be hidden by the right thumb as you hold cards in your hand. Figure 10.

Place the King of Hearts under the Queen at the "Bottom" of the deck. Then put this prepared half of the cards on the other half. By fanning cards out, faces up, you can easily find the King of Hearts. You know then to divide the cards into two packets at this point.

In handling the deck, use moderate care not to expose the index holes.

Place deck in card case.

To Perform:

Remove case from pocket and take cards out.

"An interesting experiment in thought transference is performed with a deck of cards."

Fan cards and show faces.

"A deck of fifty-two cards including the Joker. I will separate the deck into two equal halves."

As you fan cards, locate the King of Hearts and remove the cards above it. Hold prepared cards in left hand and others in right. Say to spectator nearby:

"Will you please select one of these packets?"

Hold them out for him to select, holding the right one a little closer to him. If he selects the right one, say:

"Thank you, will you please take the cards now in your own hands?"

Give him the chosen cards. If he selects the left packet, say:

"Thank you, I shall use the ones you selected. The other half of the deck I shall give to the gentleman over here."

Give regular cards to another nearby spectator. Regardless of which packet spectator selects, you keep the prepared one. Now proceed.

"I am going to ask you to select any card from the ones that you hold. Look at it, but do not let me see what the card is. While I hold my half of the deck behind my back, place your card anywhere you choose among mine."

As you are talking, slip the King from the "Bottom" of the deck to the "Top" over the Jack of Diamonds there. Protect index opening of cards with thumb. Hold cards in back of you, either squared up or slightly fanned to your left. Have spectator insert selected card into packet.

"Just square up the cards, please."

Spectator squares up cards in your hands. Now turn to face audience. Keep index opening well covered with first two fingers of right hand. With faces of cards toward you, remove fingers from index holes and cover with thumb. Now hold cards so that audience can see face of Queen of Hearts on "Bottom" of packet.

Now bring pack back to horizontal position as you talk with spectator assisting you.

"Now, sir, if you will just touch the back of my left hand with your right hand and at the same time think hard of the card you placed in the deck....."

Spectator places his right hand on your left. Raise cards to your forehead and, as you do so, lift thumb and read index of inserted card through index holes. Let us suppose the 10 of Hearts is the selected card.

"Are you thinking of your card? Think hard. It was a red card -- a heart. The - (hesitate) - Ten of Hearts. Is that correct, sir?"

Hesitate as you name color and suit and number--then come out suddenly with the name of card.

Work this up with Showmanship.

Fan the cards with right hand and remove the 10 of Hearts. Return to spectator.

"Will you, madam, also please help me with this experiment? While the cards are behind my back, just remove any card from your packet and place it among mine. Remember your card."

Spectator removes card from her packet and places it in yours. Go through the same routine of having her touch your left hand and raising cards to forehead, in the meantime getting a look at the index of selected card by lifting thumb from holes. Cover index holes with thumb again.

Suppose the selected card this time is the Ace of Spades.

"It is a (hesitate)-black card. It has writing on the face. --- The Ace of Spades."

This may be continued if you desire, having a few more spectators select cards.

"I find your minds very nicely attuned so let us see whether we cannot catch the further vibrations in the audience."

Now you may proceed with your mind reading act.

* * * * *

PRESENTING THE MIND READING ACT

If working with an assistant, have him bring out a small table with the prepared tablet on it. If working alone, come out on stage with the tablet.

Have a nice-looking easy chair nearby in which you can sit when you start to do your mind reading. Start with this Patter:

"Let me emphasize again the fact that I am not a fortune teller, a clairvoyant, or spirit medium. It is not my purpose to tell you who will be president of the United States next time or who will win the Derby Race in Kentucky next year. Even if I could predict such things I would not be allowed to tell them because of the betting that might result from such a disclosure. I have no Big Chief Indian spirit guide, nor do I go into any trance and exude ectoplasm."

"My work is to present a form of mental radio - to catch your vibrations here and there. I cannot always tell from where these vibrations come - whether from the left or right side of the house. Sometimes I catch a vibration stronger from the rear of the room than from up here in front. And when you realize the number of thoughts projected at once, you can readily understand that I must attune myself closely. It is a great deal like tuning in on a radio. A distant station may come in louder than a nearer station, and if there are too many within a small radius, it is difficult to separate them at times. And, of course, you know that some stations are practically impossible for you to get."

"I use this pad of paper to help me get impressions. I find I am of a temperament that makes it easier to get impressions when I sketch or write them down as they come into my mind. Some people find that a crystal ball helps them to concentrate, others use a silver urn or just a round piece of metal."

Scribble on the tablet to demonstrate how you get impressions.

"When I call out your question or name, or give you an indication that I have caught your vibration, raise your hand. Then I can work directly toward you."

Sit down in the easy chair somewhat relaxed with the tablet on your lap and pencil in hand. Lift up the first page a little and get a glimpse of the information copied from a slip or two.

You are now ready to get impressions. You must act as though you are concentrating and then scribble on the pad a little.

YOUR SUCCESS WITH AN ACT OF THIS KIND DEPENDS ON HOW YOU PUT IT OVER. IT MUST BE SLOWED DOWN IN PLACES AND SNAPPED UP QUICKLY IN OTHERS. YOU MUST KEEP YOUR AUDIENCE ENTERTAINED AND THEIR INTEREST AT A HIGH PITCH.

ANSWERING THE SLIPS:

There is a trick in answering the slips that spectators wrote, and a good performer can make the merest bit of information sound like a great deal. You must remember that you are playing to the whole house and not just to the person whose slip you are answering. In an audience of a thousand, only one person knows what he wrote on his slip. The other 999 do not know, and it is from the standpoint of these 999 that you can apparently work miracles. They take it for granted that you are saying the right thing to this one person, and they marvel at your power.

If you were merely to read the slips, it would be puzzling as to how you do it; but when you tell people what they wrote and give them extra information which they think is not on the slip, they marvel at you.

You can readily understand that merely to read from a slip: "Mr. William Jones has written - Sleeper Berth 9, 207B," it would be lifeless and certainly not impressive.

Remember, that you are not supposed to be reading slips, but reading minds. You must not be too accurate, but must feel your way along just as though you were actually catching mental vibrations.

Here is the way to handle the information given:

"I catch a vibration from someone who has the initials --W. J.--W. J.--W. J.--Where are you? It is a male vibration. Oh, there you are. That's it, raise your hand when I call

your name. We are strangers to each other, are we not? Have you ever seen me before? No. W. J. Just a minute, I shall tell you your name. It is--it begins with J.--Jones. That's it--William Jones. I catch that you are thinking of a journey. Is that right, sir? Yes--a journey by train. I see you sleeping--or rather trying to sleep on that train. About the middle of the car--you have a lower berth-- Berth Number 9. Is that correct, sir? What's that?--You want me to tell you the number of the car? Let me see. Concentrate real hard, sir. Now, I get the vibration. Two-0-Seven. (Hesitate, then come out suddenly)--B. Is that right?"

Answering in that manner, takes the audience away from the thought of slip writing. They think that the man only signed his initials, and yet you could tell him his name. They do not know that he gave you the information about his berth and car number. They believe you told him about the journey he was thinking of through your mental powers.

You told your audience to begin with that you are not a fortune teller, clairvoyant, or spirit medium; but they begin to feel that you have PSYCHIC power anyhow, otherwise you could not tell a perfect stranger his name and his thoughts about traveling.

The POWER OF SUGGESTION is a wonderful thing. It is amazing to think of what you can do by playing upon the imagination with Suggestion.

Perhaps the next question is this: "Will I be successful in business next year? David G. Bradley."

This requires resourcefulness for you do not know whether Mr. Bradley is an employee or an employer. Let us try it this way:

"I get a vibration from someone who is thinking, about the future and is wondering what the next year will bring forth. It seems to be coming from a man. Just a moment--and I will get the name--Bradley. Where are you, Mr. Bradley? There you are. Your first name is David, isn't it, Mr. Bradley? David G. You are interested in business. Business is more or less unsettled, and we are going through some rapid changes which demand close attention. You can make it a good year if you will. I see one or two months that are not quite so good, but do not worry about them--the others will counterbalance. Study every angle of your proposition, see where it is different from the other fellow's utilize your strongest assets, and if you see any leaks, stop them right away. Studying character will help you."

Another slip may read this way: "Will mother get well? Mary Stanton."

The answer may be given in this manner:

"I sense a person worrying about her mother. I get the initials of the person--M. S. M. S., where are you? That's it, raise your hand. It seems as though I see your mother sick--in fact, you seem quite worried about her. I cannot sense her true condition just now. But be sure she is in the

hands of a modern, up-to-date physician who understands diet and the various methods of treatment. And do not let her worry. You will find that a kind word, a bouquet of flowers, and lots of appreciation will help her more than words can tell. She will improve."

Another may have written: "My auto number is 15678. Kenneth Brown."

Here is your answer:

"I catch the initials-K. B. K. B., where are you? I seem to see a vibration of your childhood and another boy calling you Kenneth. Think hard of what you want me to tell you. I get a picture of an automobile. Has it to do with an automobile? My mind is led to the back and the number on the back of the car. You want me to tell the number on your car. Think of the number. Three-no, that isn't right. Now I have it. One-five-six-seven-eight. Is that right?"

The answering of questions just requires the use of common sense and judgment. Those questions which you cannot answer readily, you can just pass by. If someone wants to know the result of a certain race, campaign, or other public affair, say something on this order:

"I am sorry that I cannot answer that question. It affects the public in general and it would not be advisable for me to answer at this time."

You can always get out of private affairs gracefully by stating that you know what they want to know, but because of the private nature of the information, you will not divulge it in public.

If it involves law or medicine, you can always say that it is a question which a lawyer or doctor can best answer.

In some cases, you can say that the answer would be too long and you must hurry. You are not supposed anyway to get everyone's vibration.

In case anyone tries to force you to read their slip, do not let it worry you. Just say that you do not get the vibration at the moment but perhaps will later on as there seems at present to be an antagonistic vibration coming from some place. Get name of this person, then see whether it is on the sheet as you go on answering other questions. Perhaps the assistant can find it in the pads back of scenes and can write it on a large card and let you read from the wings.

As your answers progress you may turn over or tear off the front sheet and read directly from the second sheet, keeping it away from audience. Then tear off and crumple up second sheet, etc. If writing is with hard pencil, and you scribble a little with soft pencil, the audience cannot notice the writing already there from a distance.

You need never worry about any audience stumping you, for you have not claimed supernatural power. You can get only those vibrations which you are sensitive to, and if you are not attuned to a certain person, you are bound to make mistakes. You do not claim perfection, nor do you claim to answer all things. You merely sense mental conditions. And remember, that in an audience you can take your pick of the questions which you want to answer. If you cannot answer a question, say nothing about it.

Sometimes people ask you to locate lost articles, such as rings. You can say, "Are you sure that you did not leave it in the bathroom?" Many rings are mislaid when people remove them to wash their hands.

When the slips have names of articles, numbers of automobiles, birth dates, numbers on bills, or things of that nature, the answer is easy.

TYPES OF GENERAL QUESTIONS:

There is a great deal of sameness to questions asked in any audience. They can all be sifted down to a simple arrangement.

There are questions on HEALTH, WEALTH, AND LOVE. Those three classifications cover a multitude of things and have many angles.

There are those in your audience who have lost articles;

there are those who are merely curiosity seekers; and there are those who want to get something for nothing. There is the student who is wondering whether he will pass his examinations, the inventor who wants to know whether his patent will be a success. These questions come invariably: "Shall I make a change? Can I trust so and so? Who wrote the anonymous letter? Does so and so love me? Are we mated? How long am I going to live? (You can make this humorous by answering, 'I see that you will live until you die.')

What about a certain real estate deal? Who stole something?" And so on.

In some cases, you need not give an answer. Merely state the question and then suddenly have the vibration drowned out by a stronger one and continue with the next bit of information.

Good humor rightly applied can be used at times without offending. It is good to put people in a laughing mood. However, NEVER MAKE FUN OF ANYONE.

Suppose someone makes a drawing instead of writing a question or information. This gives you a good opportunity for SHOWMANSHIP.

Assume that Frank Smith makes a drawing of a pig. You say: "I see a picture in someone's mind. Hold it, whoever it is. It is coming from a person with the initials-F. S. Where are you, F. S.? Are you thinking of the picture? Do not change the original picture you thought of. Keep it in

mind. Have you a pencil and paper? Will you draw your original thought on a slip of paper? (This member of audience thinks you mean the picture which he drew before. Rest of audience thinks you caught a passing thought from someone. Be sure to see that this person gets a pencil and paper.) Draw the picture line for line the best you can. Have you finished? Now on this pad I shall try to draw the picture you have in mind. Think hard of it."

Tear off the sheets containing prepared information from tablet. Show blank pad.

Draw with soft black crayon so that it will show up well. Make the sketch as nearly like the original as possible. Then compare with sketch just made by spectator and show both to the audience.

You can get someone to draw a picture in the very beginning when all are writing on slips. Merely suggest it to several people in your patter and they will do it. This is a great finish for an act of this kind, and it is well worth while to work it up to perfection.

Later on in the Course, I shall discuss more angles of Mind Reading and Mental Magic. You will then be equipped to meet many occasions.

* * * * *

TELEPATHIC PICTURES

This effect is good for stage or club work. If you have any aptitude as an artist, it will work in very nicely as a super-mental feat and will help you create a sensation.

EFFECT:

Performer asks a spectator to draw any picture or symbol which he chooses on a piece of paper. He tells spectator to fold this paper and place it in his pocket so that performer cannot see it. This done, spectator is asked to concentrate on what he has drawn. Magician then takes a blackboard or large piece of cardboard or a pad of paper and draws a similar picture. Spectator unfolds his paper and checks up his drawing with that of the Magician. This may be varied by having the spectator write a sentence and keep it from the Magician. Performer then reproduces the sentence word for word on the cardboard or pad.

PARAPHERNALIA:

1--A book with paper jacket on it, such as most books have to advertise it and protect the cover. Use a book in a size that is convenient to handle.

2--A piece of black carbon paper for pencil transfer. Carbon comes in various qualities. You must have the kind which readily transfers pencil markings.

3--A fairly hard pencil. No. 3 is suitable.

4--A black marking crayon.

5--A sheet of white cardboard, about 11x15 inches, or a size convenient to carry.

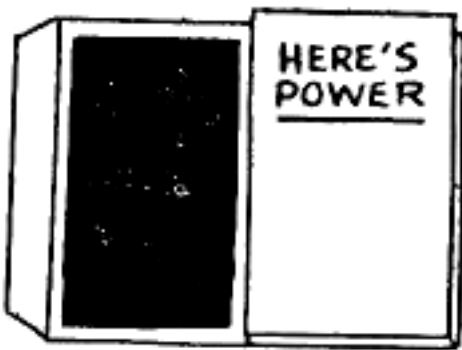


FIG. 11

To Prepare:

Cut out a piece of the carbon paper, making it about one-half inch smaller all around than the book. Paste it by the corners to the inside of paper jacket on front cover. Have carbon side toward outside so that when jacket is replaced on book, carbon side is next to book.

Figure 11.

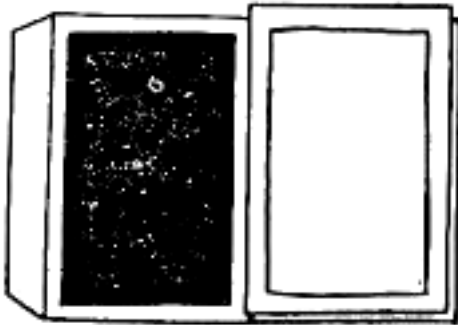


FIG. 12

Place a sheet of white paper the same size as the carbon on the front cover of the book so that it is directly under the carbon when book is closed. If you desire, you may paste corners of this paper to book.

Figure 12.

Place the jacket carefully around the book again. Trim it down so that it laps front cover only about one inch. If you do this properly, the book looks like an ordinary book and no one suspects that it has been tampered with.

Now—when a piece of paper is put on the front side of jacket and is written or drawn on, the pencil marks are immediately transferred to the paper underneath the carbon inside of the cover of the book.



FIG. 13

Figure 13 shows how the drawing is made on a piece of paper on top of the book. This same drawing is now also on the piece of paper inside the book.

This prepared book is a valuable piece of apparatus and can be utilized in many ways. It is a common thing to use a book to write on, and therefore this book does not arouse suspicion. When you give it to spectator, he thinks you are merely giving him something handy to write on.

To Perform:

Have a gentleman come forward to help you and have him stand at your right as you face audience.

"To begin this experiment, I am going to ask you to take this piece of paper and this pencil—or if you prefer, just use your own paper and pencil—and draw anything you choose. It may be just something simple—a symbol of some kind, or an animal, like a pig or horse. Draw anything you want to—the main thing is to draw something. When you do it, however, hold your paper so that I cannot see it under any circumstances."

Give spectator the pencil and paper, then pick up book and place the paper on the front side of jacket, directly above concealed carbon.

"You do not have to make a fine oil painting—just any simple drawing that you can make quickly—anything that comes into your mind. While you do this, I shall turn my back."

Go to other side of stage and turn your back as spectator makes picture.

"After you have drawn the picture, fold up the paper and hold it or place it in your pocket so that I cannot possibly see it."

When he is ready, turn around and pick up cardboard from table. Hold in right hand.

Take book from spectator with left hand, holding front cover upward. Place cardboard on top of book and hold both in left hand. Take pencil from spectator and place in upper coat pocket or vest pocket. Stand a little to left and back of assistant.

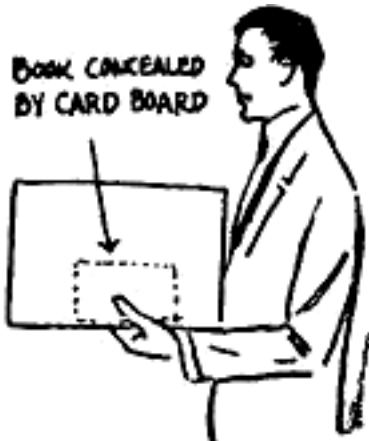


FIG. 14

Now hold card and book up vertically in left hand with book concealed behind card. Neither assistant nor rest of audience should see book. Figure 14.

"Have you ever had any experience in mental telepathy, sir?"



FIG. 15

As you say this, bring card and book farther toward right. Allow book to fall at right angles to cardboard, supporting it on fingers of left hand. With right hand reach under front cover of book and pull jacket free of cover. Let jacket just lie on top of front cover so that when proper time comes it will be easy to lift it and see the drawing reproduced through the carbon paper on the paper on front cover of book.

Figure 15.

"Have you ever suddenly had a feeling that so and so was doing a certain thing and then found out that exactly what was in your mind has happened? Some people call these feelings presentiments, others just call them hunches. I have asked you to draw a picture of some sort for me. You still have the paper."

Eyes of audience go to spectator. As their attention is MISDIRECTED to assistant, you raise cardboard in front of body to within a few inches below your chin. With right hand lift upper flap of jacket. Glance quickly down and look at the picture transferred to paper above front cover of book.

It takes but a moment to do this. Do it in a flash and let jacket fall back into place. Now allow book to come up into vertical position against cardboard again.

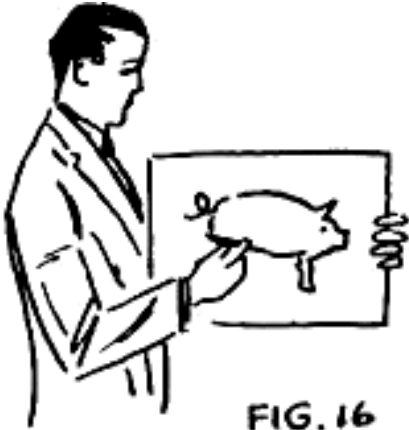
Let cardboard drop toward rear so that book is exposed. Do this as you gesture with left hand toward spectator.

"Now, I want you to concentrate on what you placed on the paper. Keep it well in mind."

Drop book on the table as you say this, and pick up black marking crayon.

"Sometimes it is almost impossible for me to catch certain mental vibrations, but I believe you are going to be a good subject and will concentrate so that I will have no trouble in performing the experiment."

"On this card I shall endeavor to follow your mental thought waves and vibrations so that I can duplicate as nearly as possible your thoughts. You think of the drawing you made and keep your thought moving on the lines of it."



With your right side turned to audience a little, hold card in left hand and pushed against chest for support. Begin to draw, making sure that audience can see you easily as you progress with drawing. Make the drawing as nearly like the spectator's as possible.

Figure 16.

"Now, sir, will you please unfold your slip of paper and let us all see whether I have caught your mental vibrations."

Take paper from spectator and show drawing to audience.

"I have been pretty successful, have I not?"

Spectator nods.

Pass drawing on paper and your cardboard down through audience so that all spectators can see that you have duplicated drawing.

Harlan Tarbell

TARBELL SYSTEM, INCORPORATED, Chicago.

* * * * *

LESSON 30

Your next lesson is no less than a whiz of a lesson. It takes you into the business side of Magic; it tells you how actually to get into the real money-making side of Magic; it explains how you can get dates and bookings; and it tells you about the effective ways of advertising yourself.

Furthermore, it gives you more valuable instruction on the Arranging of Programs.

And with all this, you get the Chinese Production Box and many other effects.

MAKING MONEY WITH MAGIC

Whether you use Magic as a Profession, as a Semi-Profession, or just as a Hobby, you can make it pay you well.

The world is hungry for entertainment and is eager to pay for it. Amusement seekers spend millions every year just to be entertained. You can get in on a share of these millions.

I want you to be a performer who is well paid for his services. I want you to be so clever with your work and so successful that your services will be in demand at a high figure. I do not want you to be known as a CHEAP entertainer. A few underpaid dates may be all right for a few performances while you are breaking in or testing out your work, but if you continue playing them, people will associate you with cheap performing.

Be a Master

Success begets success. Charge good fees and cater to those who can afford to pay them. Assume the part of a Master Magician. Arrange your programs to get miracle effects. See that your publicity paints the right picture of you. You do not need extravagant material—all you need to do is to present everything at its best.

Believe in yourself--in your ability to do things. Feel in your very bones that you are a Master. Feel it strongly yourself--and others will feel it, too. I do not mean by this that you should be conceited or a "know-it-all." People hate conceit and bragging. You can make yourself appear great and feel great without saying a word. Merely surround yourself with an atmosphere of genuine and substantial confidence based on a real knowledge. The Master does not have to go around telling people how much he knows. He just makes them feel it. His every word and action, without conceit, are impressive. And so people get the thought that he is a real artist.

Sell Yourself

Make your effects talk for you. Study every possible angle to get the most out of every effect. Strive constantly to perfect everything you do. Watch for features that will make you stand out from the ordinary and make people talk about your ability.

Then you are ready to sell yourself and sell every effect you perform. Remember that two men may be given the same effect --one will build a reputation for himself with it--the other will fail utterly with it. It is YOU that counts--your Salesmanship, your Showmanship.

You know best the tricks--little and big--in your own personality which can help you sell yourself to your audience. Study them and capitalize on them. Bring them out to give you power.

Talk the language that your audience can understand—by that I mean "get under the skin" with them. Show them that you are friendly and understand them and want to please them. You will then gain their confidence, their friendship, and their admiration. And thus you sell yourself.

Be a Successful Showman

The Successful Showman has the great faculty of adaptability in his mental makeup. When in Rome, he is a Roman; when in Greece, he is a Greek. By that I mean that he readily adapts himself to the situation in which he finds himself, always keeping his poise and control.

Elbert Hubbard said, "Love the things that I love, and I will love you; but hate the things I love, and we part company."

I cannot drive that home to you too strongly. People admire the man who is in sympathy with them and understands them. Remember that you are being paid to entertain these people, and it is up to you to study and understand what is entertainment to them. Learn what they like - what they are interested in - and with your entertaining, enter into their very lives.

On your ability to do this will greatly depend whether you get \$10 or \$100 for a performance. Houdini was paid as high as \$1000 for a performance because he was Houdini. He started out as a poor boy, but he studied and mastered SHOWMANSHIP. He adapted himself to his audience - he got their interest and confidence. And in the end everyone rushed to see Houdini play and paid big money for it. You can rise to success, too, if you hit out in the right direction and let nothing swerve you from the right road.

Make Your Magic Fit Your Audience

Right in line with the subject of adapting yourself to your audiences is the important consideration of suiting your Magic to your audiences.

You will find that certain types of effects appeal to certain people. This brings to mind the salesman who carried two lines - hymn books and playing cards. To those who would not buy playing cards, he sold hymn books, and vice versa. You can do the same with Magic. Carry different "lines" to suit different people in your audience.

Men, as a rule, like card tricks and sleight of hand manipulations, tricks with coins, cigarettes, cigars, and other articles with which they are familiar. Women usually like silk handkerchief tricks, flashy silk productions and vanishes, and effects filled with color. They like spiritualistic, psychic, and emotional effects. Children like effects with live animals, candy productions, and effects with articles which they have occasion to know and use. They go wild over the type of trick known to the Magician as a "Sucker" trick, in which they think they have caught the performer and exposed his trick. That is one of the beauties

of the Egg Bag Trick, in which the audience thinks the performer placed the egg in his pocket. At a children's party, a rabbit or a guinea pig or some other live animal adds great interest and spice to the occasion.

All this does not mean, however, that men do not like silk productions or women sleight of hand or work with live animals. They do. But they tend to be particularly interested in things which are peculiar to themselves. What you must do is remember to keep everything suited to the occasion and the audience and to give enough variety to please everybody.

* * * * *

MAKE MONEY FOR OTHERS:

A big secret in making money is your ability to make money for others. In direct proportion to the money you make for others is the amount of money you make for yourself. In performing, as you increase the attendance to swell the box office receipts, up goes your value in dollars as a Magician. In the theatrical world certain actors are a box office attraction. They have pulling power, and when they appear the theater is crowded. In your work as a Magician I want you to study the various tricks used to draw crowds by creating the proper impressions and suggestions. Remember that the attraction which pulls in \$10, 000, of course, is always worth many times more than the one which draws in only \$50—and, naturally, the one that draws the crowds and brings in the money is paid BIG MONEY.

HOW TO GET STARTED:

Start with a firm foundation, and build your structure step by step. Fly-by-night methods are too flimsy. They don't hold up under pressure. Know your work thoroughly and you have a foundation which nothing can destroy. You may make mistakes in the beginning, but let those mistakes spur you on to perfection. Everyone makes mistakes, but wise is the man who profits by them and does not repeat them.

Experience will teach you a great deal. You will learn which tricks stand up for you. You must learn how to present them in the best possible manner. You must learn the little details which it is impossible to teach you - details which have much to do with your success. They arise as you perform and experience will teach you how to turn them to your own good.

All Magicians must go through the process of testing - or, as the profession calls it, "Trying it on the dog," or "Working out in the sticks." With each performance they learn something and gradually perfect their work.

Feel your way along. Know your ground before you venture into big things. Keep your eyes and ears open. Watch and learn. You must become thoroughly grounded first - before

you will be the financial success I want you to be.

WHERE TO START:

Do not try to jump into vaudeville or the theater right at the start. Train for it first. Then when the time comes, you will already know the "ropes" and will know how to make good. The chances then of failure and dreadful discouragement are minimized.

You need not go into the theaters to make money with Magic. You can make thousands of dollars without ever entering the theatrical field. Even if vaudeville is your ultimate aim, get your start elsewhere. There are unlimited opportunities to entertain for a good profit. Thousands of societies, clubs, schools, churches, are constantly trying to raise money. Here is your chance to make money by making money for others. There are thousands of other organizations always on the lookout for good entertainment merely to keep up interest in their membership. Give them a good show, and they will pay you good money.

In your Tenth and Twentieth lessons, I gave you a few hints regarding the introduction of small programs into clubs, schools, and churches. I hope that by this time you have presented a few programs with good success.

Make appointments with the various noonday clubs as well as those which meet in the evening. Submit your services to lodges, Y. M. C. A. 's, and other organizations. You are sure to get some engagements.

WHAT TO CHARGE:

After you have done enough test work to see that you are working right, begin by charging \$15 for an engagement. This is for a program running from fifteen minutes to half an hour. As you become more proficient in Magic, step up your charges to \$20, then \$25, \$35, \$50, \$100, and so on.

For out-of-town dates, be sure to add your expenses to your fee.

In the Profession of Magic, you will run across many people who will try to get your services for nothing. Avoid them - except in the beginning for test work or just as a social favor to some friend. Make it known that your Magic Is PROFESSIONAL, and that you charge a substantial fee for your services.

People oftentimes judge you by your fee, so keep it high enough. Strangers are a better field than close acquaintances from whom to get engagements. Cater to those who do not know you too intimately. Acquaintances are apt to discount your ability and the remuneration for your services. Strangers, on the other hand, are willing to pay you well if you are worth it. Remember that high fees help you, and they boost the Magic Profession.

* * * * *

We come now to the subject of a whole evening's show, lasting about an hour and a half.

You have been given some excellent material for an evening's performance, and you are ready to make up a fine program which will be easy to carry and will cost little to produce.

A little farther on in this lesson, I give you two excellent program arrangements. You may use these as they are or work up your own. Then as the Course progresses and you get more and more spectacular material, you can add or subtract from your program which you are going to use now. You can continue this adding of effects and rearranging until you reach your ideal program.

Now, with a full evening's program, you are ready to venture forth to help others make money and to make good money for yourself.

WHAT TO CHARGE FOR FULL EVENING'S SHOW:

Here is a church that could well use the services of a good Magician. Go to the minister, the head of the men's or women's organizations in the church, or the young people's society -- and show them how you can make money for them.

Present your plan in this way: They are to furnish the hall or auditorium and you will furnish the show. Admission is, of course, to be charged, and you will work on a percentage basis. Because of your initial expense in putting on the show, you will charge the first \$25 taken in for yourself. Then you will split fifty-fifty on the rest of the proceeds. Or you may work on a straight percentage of two-thirds for yourself and one-third for the church. Percentages vary according to conditions and may run from 60-40 to 75-25. You, of course, always get the bigger end. On some occasions, a fifty-fifty percentage works out well. Many things must be taken into consideration in determining this percentage -the size of the crowd expected, etc.

Some performers prefer to play for a flat rate of \$50, \$75, \$100 or more. The percentage system, however, is a good one to work on in some cases.

HOW TO GET BOOKINGS:

It is well to make your first bookings personally. In some cases a well written letter will serve the purpose, but, of course, personal contact when possible is better.

Some Magicians prefer to hire an advance man to book for them. You may have a good friend who would like to get dates for you on a percentage. Commissions vary all the way from 5% to 33 1/3%. The advance man's commission is figured from the amount that you net from a performance. If playing clubs, schools, churches, and other such single dates, the percentage is higher than if you play vaudeville where bookings are made in lumps. In the case of single dates, the advance man has expenses and he must work on each date individually. Commissions of 20% and 25% are permissible for this work.

Some Magicians find it profitable to work in this way. They travel in an automobile, and when playing a certain town, they run over to nearby towns to book dates personally. Most of their performances are in the evening, so that they have their afternoons to spend in booking future dates.

One student came up from Indiana to visit a friend in Chicago. He booked three dates on the way up and played them on the way home, and booked four more dates on the way home for the future. That trip proved to be a profitable one for him.

Some performers work independently. They go into a city and rent a hall or auditorium. Then they depend on billing the town and advertising in the papers to bring in the crowd. It is better in the beginning, however, to work under some organization such as a church or Kiwanis Club and get your bookings from them. This organization then works to get a good attendance at your show and spreads publicity for you. They also sell tickets in advance so that a good seat sale is assured ahead regardless of what the weather will be.

As your experience and finances grow, you can get in touch with theatrical managers and play their theaters on a mutual commission or flat rate basis for each engagement. Before you reach this stage, however, you must work up an unusual type of Magic show and must have an extensive line of advertising and publicity.

ADVERTISING AND PUBLICITY:

If you play under the auspices of some school or other organization and depend on public response for your returns, it is necessary to carry your message to the public in such an interesting way that they will want to see you. You must let the town or city know that you are coming -- and you must get the curiosity and interest of the people aroused to the point where they feel they must see you perform.

Many Magicians have a publicity man or manager. This man studies the problem of presenting the Magician to the public as an attraction of unusual interest. He can praise the Magician in no uncertain terms, whereas the Magician would be considered conceited if he used such glowing language himself. Clever publicity managers can absolutely "make" a performer. To begin with, however, you will probably have to handle your own advertising.

Besides the word of mouth advertising which an organization gives you, you must spread publicity in other ways. I give you here suggestions for Window Cards, Newspaper Advertising and Publicity, Folders for Mailing and Handing Out, Business Cards, Business Stationery, and Use of Photographs.

As I explain each, I show you a drawing of that particular piece of advertising in reduced size. At the end of this section on Advertising, I give you these suggestions on a separate sheet so that you may show them to your printer when you have them made up. The business card and the folder are full size. The window card is, of course, reduced in size.

Window Cards -

Window Cards may consist of anything from hand-made show cards to elaborate lithographs. I started out by making them in show card style, 14 x 22 inches. I made a funny drawing on each and tried to make them so interesting that people would stop to read them. Sometimes I used ordinary sheets of brown paper with a picture and lettering on them, and they gave me excellent results. In France during the war I put on a performance at the Municipal Theater at Clermont-Ferrand with the assistance of some of the members of the 24th Balloon Company. I made up twelve big posters on show card order and hung them up in prominent places. They were on paper, 28 x 42 inches in size, and were made in colored silhouette style. These posters, together with a small amount of newspaper publicity, did the trick, and the theater was packed. It was a usual thing to see a dozen or more people looking at the posters at various times.

A good show card writer or sign painter in your town can perhaps give you a start by making a good permanent card for you. It is an advantage to have this because you can take it from place to place and display it in prominent store windows wherever you go. Be sure to have a good photograph of yourself on this card - or even three or four photographs --showing yourself doing various tricks.

Coming!
YOUR NAME

*Your
Photograph
Here*

Eminent
MAGICIAN
and Super-Mentalist
Mysteries You Will Never Forget

*(Space for Place and Date)
(Can Be Put in by Hand)*

If you find it too expensive to have a poster hand-made, I suggest this very inexpensive substitute. Have your window announcements printed on paper, about 14 x 22 inches and have just a few printed on cardboard. Get a good photograph of yourself doing a feature trick, and be sure that the photographer gets human interest into it. Have a half-tone cut made from the photograph. Your printer can have this done for you. A large cut is, of course, more effective than a small one.

The illustration gives you a layout showing how a Window Card, whether on paper or cardboard, should look.

Folders for Mailing and Handing Out -

A great help to you in your work is a good folder which you can mail out to various organizations and which you can leave with those whom you interview. It sometimes brings in many dates.

I give you here a layout for a folder which your printer can follow. Have him set it up and run off, say 500 copies to begin with. Use white, ivory, or India tinted

paper with enamel finish printed with rich brown or blue ink. Get four good photographs of yourself doing feature tricks. Have half-tone cuts made of them by a good engraving house -- the sizes these should be are marked on the layout for the folder. Have the engraver use about 120 screen on them. The folder has four pages and is made up of one sheet printed on both sides and folded in the middle.

The photographs should be only half figures. One may be a closeup. Tell the photographer that you want to get a great deal of interest into them -- something with sales power.

If you have a good press notice or recommendation from some organization which is short and snappy, have it set up in small italics somewhere on the folder. It is a good idea to get recommendations after you play a date. Watch the newspapers and club bulletins and such for articles about you. Put them away in a scrap book for future use in selling yourself. Perhaps you have played some schools in a certain county and can get the Superintendent of Schools sufficiently interested to give you a recommendation -- or perhaps the superintendent of the individual school will give you a good testimonial. Earn your way through as a gentleman every time and make your work so good that people will be glad to recommend you.

To return to the folder--Be sure your name and address are on the folder so that people can get in touch with you. In mailing the folder, always use first class mailing as this is the safest and quickest way to send it. When you interview people personally, leave a copy or two of the folder with them for future reference.

*Halftone cut
of yourself
performing
another trick*

Size 2 3/4" x 2 1/2"

Mystery after Mystery in Rapid Succession

The Cream of Magic at Your Command

*Combined with Super - Mental
Problems of an Amazing Nature*

**American, European and
Oriental Effects**

Special Comedy Features for Children

*Halftone cut
of yourself showing
a boy or girl in effect.
This cut is to show that
you cater to children.*

Size 2 3/4" x 2 1/2"

Special Programs for

- Clubs
- Schools
- Churches
- Parties
- Banquets
- Lodges
- Children's Parties

*Just the Entertainment You
Would be Pleased to Offer
the Public*

**DO YOU WANT TO
MAKE MONEY FOR
YOUR ORGANIZATION?**

**You Can Do It Easily
with this Evening's Program
of Modern Miracles**

*Halftone cut
close-up of
yourself performing
a favorite stunt*

Size 2" x 2"

Always Something New

**Where Can You Find Better
Entertainment Than Magic?**

Let's Talk It Over

Your Name and Address Here

FOR YOUR NEXT ENTERTAINMENT

*Halftone cut
of yourself
doing a
magical effect*

Size 1 1/2" x 2 3/8"

YOUR NAME

Magician
and Super-Mentalist

Mysteries You Will Never Forget

— 3' —

← 3' →

Suggestion for Folder:

Illustration is full size.

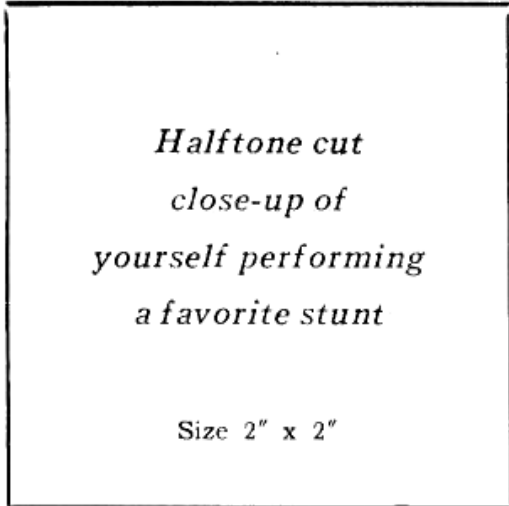
This gives the Front and Back Pages. Fold comes along middle line with pages facing outward.

Rear Page

Front Page

**DO YOU WANT TO
MAKE MONEY FOR
YOUR ORGANIZATION?**

**You Can Do It Easily
with this Evening's Program
of Modern Miracles**



6 1/4"

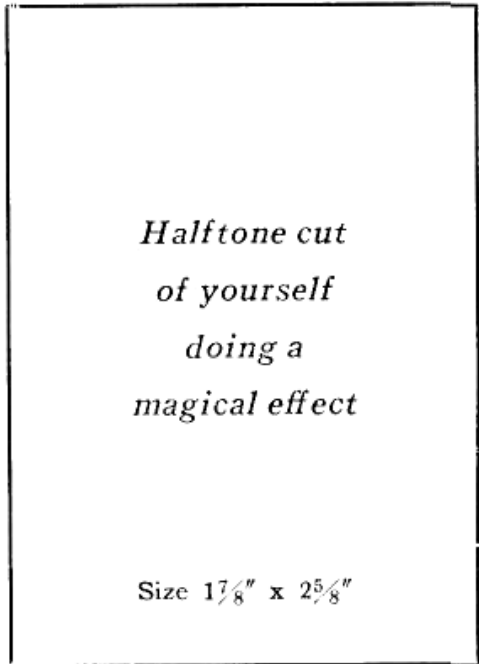
Always Something New

Where Can You Find Better
Entertainment Than Magic?

Let's Talk It Over

Your Name and Address Here

**FOR YOUR NEXT
ENTERTAINMENT**



YOUR NAME
Magician
and Super-Mentalist

Mysteries You Will Never Forget

Page 4

Page 1

← 3" →

Suggestion for Folder:

Illustration is full size.

This gives the two inside pages. Fold comes along middle line with pages facing inward. Folder is, of course, made up of only one sheet-- printed on both sides and folded in the middle to make four pages.

First Inside Page

Second Inside Page

*Halftone cut
of yourself
performing
another trick*

Size 2³/₈" x 2¹/₂"

*Halftone cut
of yourself showing
a boy or girl in effect.
This cut is to show that
you cater to children.*

Size 2³/₈" x 2¹/₂"

**Mystery after Mystery
in Rapid Succession**

**The Cream of Magic
at Your Command**

*Combined with Super - Mental
Problems of an Amazing Nature*

**American, European and
Oriental Effects**

Special Comedy Features for Children

Special Programs for

- Clubs
- Schools
- Churches
- Parties
- Banquets
- Lodges
- Children's Parties

*Just the Entertainment You
Would be Pleased to Offer
the Public*

Suggestion for Window Card:

This illustration is much reduced in size.

Coming! YOUR NAME

*Your
Photograph
Here*

Eminent

MAGICIAN

and Super - Mentalist

Mysteries You Will Never Forget

*(Space for Place and Date)
(Can Be Put in by Hand)*

Business Cards -

Have your printer also make up for you a good business card. Make your card a little different so that it will attract attention. In time when you are well on your feet, you can afford to have a good hand-lettered card. Below is just a suggestion for a neat, attractive card. The card may be the size of this illustration, or larger.



Business Stationery -

Good stationery looks business-like and makes a good impression for you. People judge you in advance of seeing you by these impressions, so that it is important for you to impress them with the fact that you are successful.

For your stationery use a good bond paper with a neatly designed letter-head and envelope-head, perhaps printed in blue ink. Sometimes just a cheap manila stock works up wonderfully for Magic stationery. A red and black effect or a dark blue show up fine and can really make such cheap stationery look distinctive. Try to get your stationery to look more attractive and different from the usual. It is possible to work wonders with little expense.

Newspaper Advertising and Publicity -

Arrange with the local newspaper to use a certain amount of advertising space, well placed, and suggest that the editor give you a few words of write-up in the news columns. If you are working under the auspices of a church or school, they perhaps have some influence with the newspapers, and can use it to get you publicity.

You should have a good half-tone cut of yourself for newspaper use. It should be about two inches wide by two and a half inches high. Just tell the engraver that you want a newspaper cut and he will take care of you. Use this cut in your newspaper publicity, as such publicity is doubly effective with your picture.

Here are some suggestions for newspaper notices which you may use as a basis for writing up your own:

NOTED MAGICIAN COMING

Morton High School Announces Novel Attraction for Next Tuesday Night

Hold on to your pocketbooks and be sure there are no rabbits up your sleeves for (Your Name), the famous Magic Man is coming. He will present his ever-popular program under the auspices of the Morton High School at the High School Auditorium next Tuesday, March 8, at 8 p. m.

(Your Name) is an unusually clever performer and presents in his evening's program odd mysteries which he secured from countries all over the world. "The Spirit Mathematician," "Hindu Egg Mystery," "The Haunted Lemon of Ching Foo," and "The Mysterious Japanese Thumb Tie" are only a few of the bewildering experiments which he will perform.

Super-mental feats will occupy the second half of his program. One of his great effects in this line is that in which a member of the audience draws a picture on a piece of paper which (Your Name) does not see at all but which he nevertheless reproduces on a piece of cardboard before the spectators. (Your Name) is famed for his unusual ability in catching mental pictures.

This performance is open to the public. A high degree of interest has been manifested, and a record attendance is anticipated.

HIGH SCHOOL TO HAVE MAGICIAN

(Your Name) Coming With Big Evening of Mysteries

A big evening of mystery and illusion will be that of Tuesday, March 8, at 8 p. m. at the High School Auditorium of Morton.

(Your Name), the famous Magician, is coming with his ever-popular array of odd and baffling effects. His great mysteries come from the Orient -- from Europe -- and from America, and he is famed far and wide for his interesting presentations. Among his feature numbers is the great Paper Mystery of Ching Ling Foo, the greatest of Chinese conjurers. Even Magicians have been baffled by this profound mystery.

This is (Your Name)'s first appearance in this community, and a large attendance is expected for the rare treat. Proceeds will be used for the benefit of the Athletic Club.

(30-10)

GREAT MYSTERY MAN COMING

(Your Name), Magician, to Present Evening of Wonders at First Methodist Church Auditorium

The Magic Rabbit is getting ready to make his unexpected appearance at an odd mystery program to be given by (Your Name), the Magician, at the Auditorium of the First Methodist Church, Wednesday night, March 8, at 8 p. m., under the auspices of the Men's Bible Class.

It has always been a mystery how a rabbit could appear and disappear in so many places. He is likely to tumble out of almost anyone's hat and just as likely to vanish in some gentleman's whiskers. (Your Name)'s rabbit is like that. His antics will give you many minutes of fun.

Some of the Oriental mysteries on (Your Name)'s program are particularly interesting. He presents the bewildering "Haunted Lemon of Ching Foo," "The Wandering Egg," "The Spirit Communication," and "The Japanese Thumb Tie," among others.

(Your Name) has been interested in the mysteries of the Orient for some time, and he gets as much delight in performing them as his audience does in seeing them. Special effects in Super-Mentalism are also combined with these mysteries. (Your Name) determines in advance what spectators will think of and catches mental pictures from the minds of spectators. One of his great Super-Mental feats is to have a spectator draw a picture. (Your Name) catches the vibrations and, though he never sees the picture, he reproduces the drawing right before the audience.

The entertainment is for the whole family. For everybody -- young folks to old folks -- Wednesday night will be the most enjoyable evening spent in a long time. The proceeds will be for the benefit of the church.

ARRANGING AN EVENING'S PROGRAM

Building a Magical program is like building a play or any kind of theatrical production. It must be so designed as to gain attention at the very beginning and to hold that attention to the final drop of the curtain. That is done by sustaining interest. You stimulate the emotions of your spectators -- then you let them rest -- then you stimulate them again -- and so on. To accomplish this, you inject variety, suspense, comedy, and climaxes into your work. This keeps your audience from tiring and presents different appeals to interest everyone in your audience.

Arrangement as to type of effect:

The opening effect should be worked quickly and should be very mystifying to get immediate attention. Then should come, what is termed in the show business, a "flash." This

may be a clever production of some kind or something else rather showy. It should be worked rather fast, too, and done in pantomime style -- with music, if possible. Do something to stimulate. Then you can go into your various mysteries. In the middle of your program, put a big feature number to renew attention and stimulate your audience again. Then continue with other good effects. And finally, for your finish perform a sensational effect to leave your audience puzzled and talking about you.

Number of Acts:

The number of acts depends, of course, on the occasion and conditions under which you are working. It also depends on your own particular personality and the way in which you can work to the best advantage.

Some performers like to use only one act. Others like to divide the program into two or three acts. If you are doing Super-Mental work, it is well to have two acts - the first one of Magic, and the second of Mental effects. Or the program may be divided into three acts -- the first one consisting of Magic, the second of Super-Mentalism, and the third of Magic again.

The show should run from an hour and a quarter to an hour and three-quarters. Regular theatrical performances may run two hours. Divide your acts up to fall within this length of time. The tendency of the beginner is to run his program too long. You can overdo as well as underdo. Keep things moving and remember to STOP at the proper time. Use the vaudeville system of running on schedule time. Avoid long waits between acts -- they tire your audience and destroy your influence over your spectators. BE PROFESSIONAL all the way through. Have everything well organized and running smoothly and your audience will feel that you are well experienced and a MASTER in your art.

Grouping of effects:

In grouping of effects you must follow a logical sequence. A hodge-podge conglomeration is bad. You must make one effect blend into the next just as actions in a play do. Keep your Handkerchief work in one group, Card work in another group, Super-Mental work in another, and so forth. Step up the action and the mystification from one to another.

If you are presenting Oriental Magic in the program, keep it in groups -- Hindu Magic in one, Chinese Magic in another, etc. You may vary this rule a little. If you desire to use a Hindu effect for an opener and another for the finish, or one in the middle of your program, this is permissible, but it must be blended in very smoothly. Always keep in mind the grouping of effects for logical dramatic action.

While you must group effects for harmony, be careful not to group them for monotony. There must be good variety in your program. Avoid giving two tricks of a similar nature, unless one is used apparently to explain the other. If you

have to vanish a handkerchief more than once, make the second vanish different from the first. If you do the Kellar Cut and Restored Cord Trick, do not perform the Cut and Restored Ribbon, or the Cut and Restored Something Else. If you do a torn paper mystery, select the method which appeals to you most and accent it. Do not give three or four methods even if they are different -- the effects are somewhat similar. Feature certain effects and do not weaken their power by similarity to some other effect.

You have plenty of tricks to give your program SNAP AND VARIETY.

Framing the Act:

Putting an act together is called "Framing an Act."

Let us look over the many tricks we have learned and with them frame an evening's show. As you progress with the Course, you learn more and more spectacular effects and illusions, but even as far as you have gone, you have a wonderful repertoire with which to put on a "humdinger" of a show.

At the end of this section of the lesson, I suggest two programs for your show. These will help you organize the program which you want to present. You can substitute effects which you want to present. You can substitute effects which you prefer for some of those given, and work up a show to suit your own personality. The BIG IDEA is there for you to follow, and with this as a basis you can work up a mighty interesting program.

Names of Effects for Programs:

Many of the names which I give to tricks in the Course are, of course, merely for description. Some of these names, however, are too obvious to use for the public. Names of tricks used in newspaper publicity, advertising, or printed programs must not reveal the nature of the effect to the public. For instance, you and I would talk to each other about "The Cards Up the Sleeve." On the program, however, we would give it a name like "Invisible Transit." The name, "Japanese Torn and Restored Paper," is too explanatory and should be changed to something more mysterious, like "A Japanese Mystery," or "The Magical Napkin." The name, "Miser's Dream," is all right -- so much better than "Catching Money in the Air."

At times, too, you will want to vary your program, and if a name is general, many effects can be worked under that name without having your audience know. "Invisible Transit," "Japanese Mystery," "The Miser's Dream," for example, might apply to anything from a Coin, Card, or Handkerchief Trick to an elaborate stage production.

As the showman once told his publicity man, "Advertise heavily about our big Hippo." "But," replied the publicity man, "the Hippopotamus that you ordered may not get here in time." "In that case," said the showman, "the Hippo will be

the Hippodrome." That illustrates the advantage of a general name.

For your work at this stage you do not need printed programs for distribution to the audience. They would add to your expense. I explain to you about them here, however, because some organizations get up souvenir programs and I want you to be prepared for such emergencies.

Amount of Paraphernalia:

The two programs which I suggest for you have been organized so that each can be presented with or without an assistant. Each has been worked out also so that it can be packed into a suitcase. Outside of a traveling bag for your rabbit or guinea pig and perhaps a package for the rabbit boxes, all you need is your suitcase.

The packing of your program is very important. Partition off your suitcase into a number of sections, and put the paraphernalia for each trick into its own division. System is important. Keep each trick in its own section in the suitcase. Then you know just where to reach for it when the time comes, and you don't need to spend time fumbling around. Keep as nearly the same arrangement as possible for each performance, and things will work smoothly.

Use of Assistants:

Whether you carry an assistant or not depends greatly on your finances. If the assistant is a stranger, it means extra fare and salary -- and this adds quite an item to the expense account. An assistant is handy to have as he looks after details, helps you arrange your stage, and packs your show for you. Sometimes you can get more money for your act because you carry an assistant.

Often the performer's family helps him out and travels with him. Sometimes it is the wife, the daughter, or son -- or perhaps all three. If traveling is done by automobile, it is as easy to carry all three as one. The money taken in, of course, is for the whole family. And thus with one or more assistants you can build up an elaborate production.

Use of Music:

Music helps your show and smooths over many effects. Perhaps some member of your family plays the piano and can be your accompanist. I have often had music with my shows through the use of a portable phonograph and a few up-to-date records. I have the machine off stage and my assistant operates it. It has worked out very nicely. By using the new-style reproducer, you may be able to work out a nice orchestral effect. It is worth trying.

Some high schools and churches have their own orchestras and are glad to have them give you their services. Music before the show and between the acts is welcomed.

Now, for Your Program Suggestions:

PROGRAM NO. 1

Act I.

1. Opening -- The Vanishing Wand (Lesson 20).

A good opening because it is performed easily and quickly, and the vanish can be made startling.

2. Silk Production from Milady's Hat Box (Lesson 25).

This is worked on the same principle as Milady's Hat Box Rabbit Vanish - only silks are used instead of a rabbit. Take a number of silk handkerchiefs or scarfs, the brighter the color the better, and fold each one up separately. Place them together and wrap in another silk. Hold in place by ribbon, thread, or pin. Attach this bundle to lid of hat box as you did the rabbit bag. Have box on a chair. Go through same routine that you do with the rabbit production. When you finally are ready to produce silks, unfold them, spread them out and show to audience, and place each on back of chair as shown.

3. Rabbit Production from Silks (Lesson 30).

The silks are picked up from back of chair and a rabbit is produced from them.

This effect is taught to you farther on in this lesson.

4. The "Sucker" Rabbit Box Vanish (Lesson 25).

Be sure to build your box large enough to accommodate a fair size rabbit. Rabbits grow rapidly, and if your box is too small, the rabbit will soon outgrow it. You can ascertain the best size through a little experimenting. A guinea pig may be used instead of a rabbit. It will not grow to be very large and is easy to handle.

5. Chinese Paper Mystery with Wintertime in China for ending. (Lesson 4).

Use a bright red paper and much larger than the size I suggested in your early lessons. Paint Chinese characters on paper to screen ball and also for good effect. In this effect, make tissue bag on rear of fan as large as you can handle conveniently to get as spectacular an effect as possible. It is easy to dispose of envelope by tearing it to pieces in hand or merely crumpling it up and dropping to floor. The paper which I use for these effects is 5 x 25 inches in size. For stage work effects must be enlarged and elaborated on over the presentation for parlor or any close work.

6. Card and Ribbon Mystery (Lesson 26).

Instead of a playing card, use a yellow card with Chinese characters on both sides, made with black ink.

Use a bright red ribbon. Work it up in this way as a Chinese trick.

7. The Untying Handkerchief (Lesson 28).
8. Silk of the Flame (Lesson 28).
9. The Wandering Silk from Pocket to Pocket (Lesson 28).
10. King Solomon's Wedding Bands (Lesson 20).
11. The Coin in the Magical Envelopes (Lesson 22).
12. The Miser's Dream--with Coins (Lesson 23).
13. The Homing Coins (Lesson 22).
14. The Haunted Lemon (Lesson 7).

A variation of the Magic Orange off the tapes, using a lemon instead of an orange.

15. Producing a Card from a Whole Orange (Lesson 14).

You use two spectators in the preceding effect. Have the same ones help you in this effect, one to select card and one to hold orange.

16. Rising Cards (Lessons 18 and 19).

Use your favorite method.

17. Tack It (Lesson 16).
18. The Egg Bag (Lesson 24).
19. The Penetrating Ring (Lesson 11).
20. Japanese Thumb Tie (Lesson 11).
21. Coats, Tapes and Rings (Lesson 7).

NOTE:

The number of effects which you perform depends on your speed of working. Keep things moving. If you find this program too long, take out one, two, or even three tricks. You do not have to hurry to keep things in action, but be careful not to let non-essentials delay you in reaching your climax. This program should run a little less than an hour.

Act II.

Super-Mentalism (Lesson 29).

Pass out pads and pencils for Mind Reading Act. If you have no assistant, do this before the beginning of Act 1, and explain that it is being done at that time to avoid delay later on. Then if you are working alone, you can manage to develop about ten of the slips between acts. You do not need very many. Even if you answer only six, it demonstrates your mental

(30-16)

power. If you have an assistant, however, he can develop more slips for you and get the tablet ready while you perform other experiments.

1. Mystery of the Traveling Numbers (Lesson 8).
2. The Yogi's Prediction (Lesson 29).
3. X-Ray Cards (Lesson 29).
4. Mind Reading Act (Lesson 29).
5. Telepathic Drawing (Lesson 29).

* * * * *

PROGRAM NO. 2

Act I.

1. Opening – The Wand from the Pocketbook (Lesson 30).

This is taught to you later in this lesson. Vanishing Wand (Lesson 20).

2. Silk of the Flame with Cigarette Combination (Lesson 28).

Light candle. Then take match from box with silk concealed and light cigarette. Produce silk from flame; then vanish lighted cigarette in it with Thumb Tip. Place silk in vest pocket and continue with Silk of the Flame effect.

3. The Egg, the Glass, and the Handkerchief (Lesson 28).
4. The Untying Handkerchief (Lesson 28).
5. The Cut and Restored Ribbon (Lesson 26).
6. Japanese Torn and Restored Napkin (Lesson 4).
7. Thimble Act (Lesson 27).
8. Humpty Dumpty Outdone (Lesson 24).
9. The Egg Bag (Lesson 24).
10. The Card and the Banana (Lesson 14).
11. Cards That Pass in the Night (Lesson 12).
12. Cards Up the Sleeve (Lesson 12).
13. Mystery of the Glass House (Lesson 17).
14. Rising Cards (Lessons 18 and 19).

Your favorite method.

15. The Coin in the Magical Envelopes (Lesson 22).

IF YOU HAVE NO ASSISTANT, ASK AUDIENCE TO PARDON YOU FOR A MOMENT AT THIS POINT WHILE YOU PREPARE FOR THE NEXT EXPERIMENT.

Go behind the scenes and quickly prepare for the next two effects which are taught to you later in this lesson. Take rabbit from carrying case and drop him into compartment in Chinese Rabbit Box (described later). Place derby hat with bundle of silks inside the box. Bring box out and place on table.

If you have assistant, just have him bring box out all prepared for the effects.

16. Silk Production from Hat (Lesson 30).

Remove hat from box and place on table. Show box empty and set it down behind hat. Pick up hat, getting bundle of silks to rear, and show hat empty. Get silks into hat again, open bundle, and produce silks one at a

time, laying them over front side of box.

17. Chinese Rabbit Box Production (Lesson 30).

Push silks into box. Release hook and take rabbit out of box by the ears. Pick up box and show it empty. Silks have apparently changed into rabbit. Turn box upside down so that children coming to stage for next effect will not see into it.

18. Unique Box Rabbit Vanish (Lesson 25).

Have a boy and two girls come up from audience to assist you. Have them stand at front of stage. You go to rear and place rabbit in box on the stand. Drop rabbit into secret compartment in table top and go through routine. Remove box from table and wiggle it around as though rabbit were jumping inside. Ask boy whether he can hold rabbit without dropping him. As you give box to boy, wiggle it to give comedy touch. Then say, "I'll have to hypnotize him to keep him quiet." Wave your hand over box, and box then remains quiet. "There, he has gone to sleep." Put your head to box and say, "I hear him snoring. Do not drop him now. Hold tight onto the box. Here, girls." Go over to table and pick up a toy pistol and a little toy hatchet and give one to each girl.

Continue with this Patter: "You take this pistol, and if he tries to jump out of the box, shoot him. And you, Mary, take this hatchet and bean him on the ears if he gets too frisky. And, Bill, you just wait a minute and we'll fence him in."

Remove the table top quickly and in a careless manner and place it against back of chair or back wall of stage, or if you have an assistant, give it to him. Pick up the table, show it casually, come over to Bill and place it over his head.

"There, Bill, we've got the rabbit fenced in."

Place girl with pistol on one side and girl with hatchet on other. Reach over and place ear near box, and say, "I

wonder whether he is asleep yet? He seems unusually quiet. Maybe he is dead. Well, we cannot take any chances. Sally, you have your pistol ready to shoot and, Mary, be ready to hit him on the ears. I'll open the box, and if he jumps out, we'll get him."

Take box from boy, and holding lid toward audience, slowly open it a little. Then quickly close it. "Are you ready, girls?"

Open box. Of course, it is empty. Reach inside to look for rabbit supposedly--then have Bill look inside--and show to audience.

"HE'S GONE! I guess he must have died and gone to rabbit heaven. Well, good-bye, Bill."

Shake hands with the boy.

"And good-bye, girls."

Take pistols and hatchet from girls and shake hands with them.

"You did your part well, and if Bunny had jumped out of the box, I know you would have got him. But, anyway, if that rabbit ever comes back as a spook, we'll sneak up behind him and catch him when he isn't looking."

Act II.

1. King Solomon's Wedding Bands (Lesson 20).
2. The Bartender's Dream (Lesson 30).
3. Coats, Tapes, and Rings (Lesson 7).
4. Japanese Thumb Tie (Lesson 11).
5. The Spirit Mathematician (Lesson 8).
6. Telepathic Drawing (Lesson 29).
7. The Chess Knight's Tour (Lesson 29).

* * * * *

STAGING YOUR PROGRAM

Of great importance in staging a Magical performance is having every piece of apparatus in its place and in the same place, as nearly as possible, for each performance. This system eliminates groping around for paraphernalia. You know just where to locate each article almost without thinking. Each effect should be grouped by itself if possible. The partitioning of your suitcase helps this. It gives you a definite place from which to take paraphernalia for an effect so that you can work with snap--and it gives you a definite place

for clearing away your effect without delay when you have finished.

You have enough to think about in presenting a performance without having your mind loaded with unnecessary details, such as finding your apparatus. You must keep all your attention concentrated on SHOWMANSHIP and not scatter it around on many unimportant details.

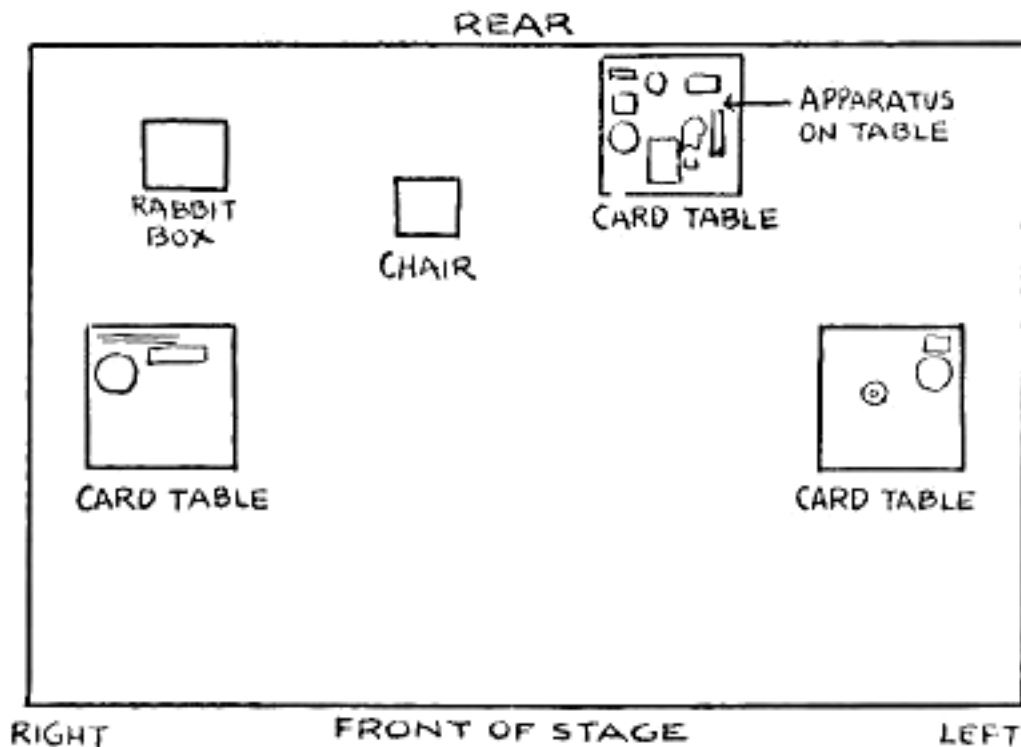
Have your show in such shape that you can set it up and pack it away very quickly. After you have had some experience in the routine of staging a program, things will begin to work more automatically for you.

ARRANGEMENT OF STAGE SETTING

Dress the stage the best you can with the material you have. Study color effects a little and style of arrangement. Keep the stage neat-looking. Keep material not in use at the moment as far in the background as possible. Things in use should be made to stand out. Because of spectators coming up to assist you, be sure that apparatus on stage is well protected against close observation. A handkerchief or cloth will help to conceal things. Keeping things far back also helps to conceal them. Sometimes one or two effects can be kept off stage until ready for use. Allow plenty of space at front of stage for spectators assisting you.

When two acts are being given, the material for the first act should be cleared away and new material set in place for the second act. This gives a new note of interest for the second act.

The illustration shows arrangement of a stage which I have used when only card tables and chairs were available.



* * *

This last section of your lesson is taken up with teaching you some new effects which were listed on your program suggestions:

WAND FROM POCKETBOOK

A novel way of producing a wand, which makes a good opening number. This is adapted to either the regular wand or the special vanishing wand described in Lesson 20.

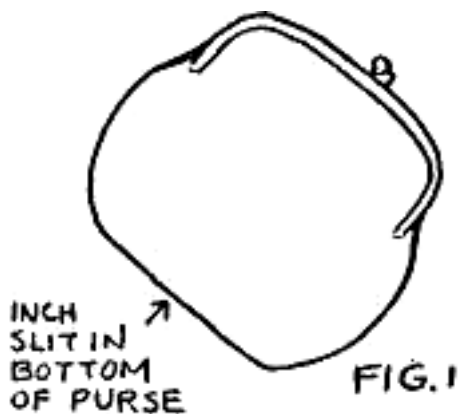
EFFECT:

Performer shows a small pocketbook, to be empty. He then suddenly draws out his wand from the inside of the pocketbook. The wand is struck on the table to show that it is solid.

PARAPHERNALIA:

- 1 -- A small pocketbook, such as is used to carry small change, with a clasp at top. About two or three inches is a good size.
- 2 -- A duplicate pocketbook, in case you want to pass it out for examination.
- 3 -- Your regular wand or the special vanishing wand.

SECRET:



To Prepare:

Cut an inch or even two-inch slit in the bottom of pocket-book, through which the wand can be easily drawn. Make edges of slit smooth. You can easily determine the best size opening in bottom of purse for you to insert tip of wand into easily.

Figure 1.

Place prepared pocketbook in right coat pocket or other pocket easily reached by right hand.

If you want to show pocketbook after production of wand, place unprepared duplicate in left trouser's pocket.



Insert wand up left sleeve, letting one end rest at base of second finger.

Figure 2.

Wand may be dropped down farther to facilitate working at times. Forearm can be raised and lowered with back of hand to audience, and wand will not be discovered. Avoid any stiff movements.

To Perform:

Remove prepared pocketbook and show freely. Conceal slit at bottom with fingers.



FIG. 3

Figure 3.

Place pocketbook in left hand with bottom of purse against end of wand. Squeeze sides of purse a little. This will open slit and allow wand to be inserted. Open pocketbook with right hand and reach in with thumb and first two fingers. Grasp end of wand and pull it through pocketbook.

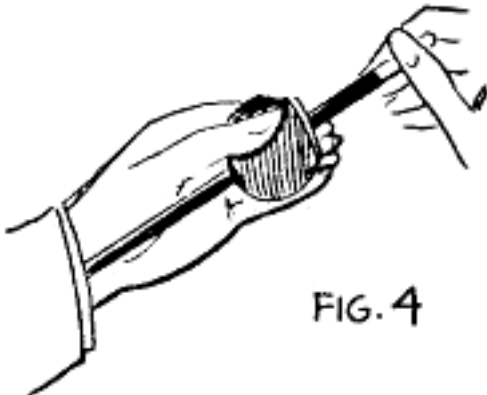


FIG. 4

Figure 4.

The effect is that you actually pull the whole length of the wand from the inside of the purse. The illusion to the audience is perfect.



FIG 5

Figure 5.

Have a table at your left. Turn to left so that right side is toward audience. Strike wand on table to show that it is solid. As you do this, reach into left trouser's pocket with left hand as it is screened. Leave prepared purse there and remove unprepared purse. Turn to face audience again. Pass out purse for examination.

In performing on the stage and in using this production for an opening number, you do not take the time to give out the pocketbook for examination, but in club or parlor work, it is a very satisfactory conclusion to the effect.

CIGAR FROM POCKETBOOK

This is one of Ed Reno's favorite effects, especially as an impromptu stunt off stage and at close quarters.

EFFECT:

Performer reaches into pocket and brings out a small pocketbook. He opens it, reaches in, and brings out a large cigar, many times larger than the purse. He then passes the purse out for examination.

PARAPHERNALIA:

- 1 -- A small purse, about an inch and a quarter wide.
- 2 -- A duplicate purse.
- 3 -- A good-sized cigar.

SECRET:

To Prepare:

Slit bottom of purse as you did in preceding effect to allow enough room for cigar to be drawn through. Insert cigar in

slit. Put both purses in left trouser's pocket. Have cigar extending upward in pocket.

Figure 6.

To Perform:

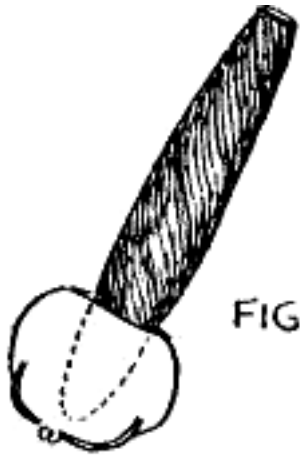


FIG. 6 Reach into pocket with left hand and grasp prepared purse. Cigar automatically comes into inside of hand. Keep back of hand to audience to conceal cigar.

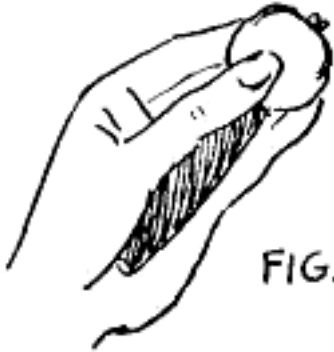


Figure 7.

With right hand open purse, reach in, and bring out cigar. Close purse and hand cigar to a spectator. As you do this, turn right side to audience. You can then exchange purses by placing hand in left trouser's pocket. Pass out unprepared purse for examination.

Reno varies this occasionally by producing a large jack-knife with open blade, or if seated at the table, he produces a table knife from the little purse.

WAND FROM CARD CASE

This effect is a good opening for tricks with cards.
EFFECT:

Performer picks up deck of cards in case, opens case, removes cards, and places them on table. Then he reaches into card case again and brings out his wand.

PARAPHERNALIA:

- 1 -- A deck of cards in the cardboard case.
- 2 -- A wand.

SECRET:

To Prepare:

Remove cards from case and in bottom of case, cut a hole about an inch long and the width of the bottom.

Figure 8.

FIG. 8 Have wand up left sleeve with end resting against middle finger of left hand. Keep back of hand to audience.

Have deck of cards in case on table at your right or in right coat pocket.

To Perform:

Pick up deck of cards and show freely but be careful to conceal hole in bottom of case. Place case in left hand and



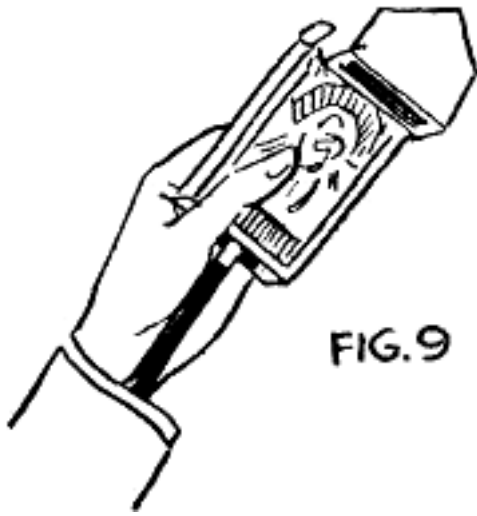


FIG.9

open flap with right, removing the cards. Place cards on table at right side, and as you do so, get end of wand inserted in hole in case.

Figure 9.



FIG
10

Reach into case with right hand and draw out the wand.

Figure 10.

Toss case on table in an apparently careless manner, but be careful to get it in such position as not to expose hole in bottom.

* * * * *

SILK PRODUCTION FROM HAT

This is for use on the programs which I suggested for you.

EFFECT:

Performer shows a hat empty and then reaches into it to produce a number of large silk handkerchiefs.

PARAPHERNALIA:

- 1 -- A number of large silk handkerchiefs, preferably brightly colored.
- 2 -- A hat. preferably a derby, though a soft one will do. You may borrow a hat from the audience or use your own.

SECRET:

To Prepare:

Fold each silk separately so that it can easily be spread out. Place silks on top of each other and wrap securely in a black or dark blue silk handkerchief. Wrap as tightly as possible and pin end of handkerchief to hold. The bundle should be oblong and as small as possible. The size of the bundle depends on your ability to hide it. About six handkerchiefs wrapped in the seventh dark one make a fair production.

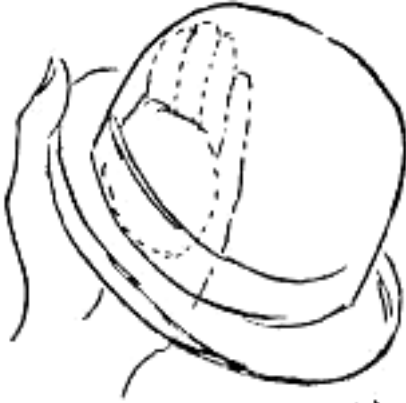
To Perform:

If you use a borrowed hat, have bundle of silks tucked up under left arm pit and hold it in place with pressure of arm against body.

Borrow the hat and hold it in left hand. On way back to stage when your back is toward audience, quickly reach up with right

hand and bring bundle of silks down to front of body. Bring left hand with hat up and drop silks into hat. While doing this start turning to right and finally face audience. To audience it appears that you merely took hat back to stage and then turned around to face them.

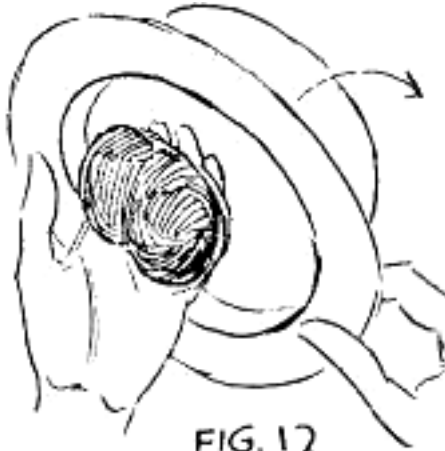
If you use your own hat, the bundle of silks may be inside of the hat ready for use.



Grasp front brim of hat with right hand and bring it upward. Have right side to audience. Place left hand in hat to hold silks and invert hat onto left hand.

Figure 11.

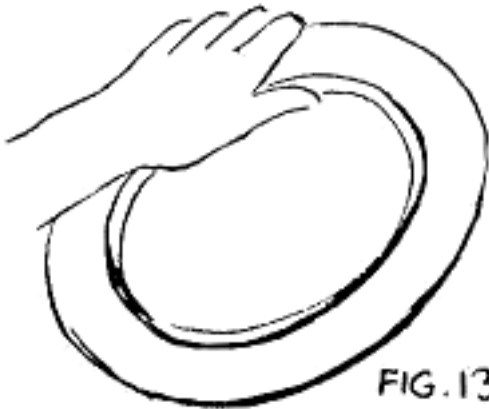
FIG. 11



Grasp edge of hat again with right hand and lift hat clear of bundle in left hand. Left fingers conceal bundle. Figure 12.

Keep turning hat until bundle is on top of brim at back of hat. It must be held and concealed all the time with left hand.

FIG. 12



When bundle is in this position, hat may be shown empty.

Figure 13.

FIG. 13

The movements for removing bundle from inside of hat so that it may be shown empty are illustrated in Figures 14 to 18. Study them carefully.

First, the bundle is in the hat--then it is pushed over to the side and held by left hand--next hat is lifted clear of bundle by right hand--then hat is revolved by right hand to get bundle between brim and crown--and finally it is turned into position shown in Figure 18 and held in left hand.

Hat is shown empty--and then movements are reversed to get bundle back inside hat. Now you are ready for the Production.

To produce silks, reach into hat and unpin bundle. Remove each silk by itself and shake to spread it out. You may hold hat in left hand and remove silks with right, or place hat on table as you remove silks.

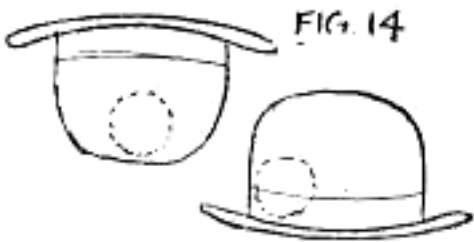


FIG. 14

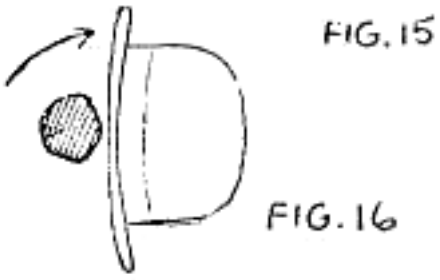


FIG. 15

FIG. 16

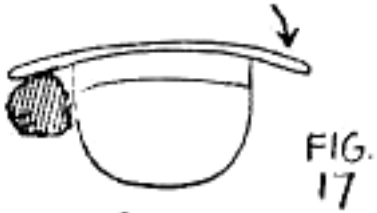


FIG. 17

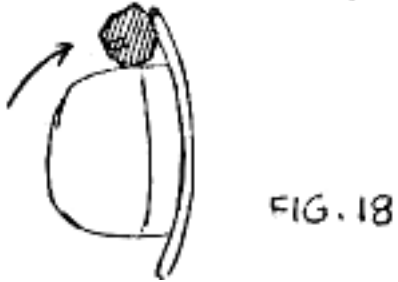


FIG. 18



FIG. 19

Figure 19.

* * * * *

CHINESE PRODUCTION BOX

A very serviceable piece of apparatus for producing, vanishing, or transforming rather large articles and live animals, such as rabbits, etc. It is easy to construct.

(30-25)

EFFECT:

A Chinese box with no lid is shown empty. Then it is placed on a table or chair. Performer shows an empty hat, then suddenly produces a number of silks from it. Magician then drops silks into box and changes them into a live, squirming rabbit which he pulls out of the box by the ears. Box is shown empty.

PARAPHERNALIA:

- 1 -- Specially constructed Chinese Box.
- 2 -- Several silk handkerchiefs.
- 3 -- A rabbit.

SECRET:

To Prepare!

The box which I use is 12 inches square—the size may be varied according to size of production. For a long time my box was made of corrugated cardboard with the edges reinforced with gummed paper tape. I painted the tape dark green.

On the box itself I painted Chinese figures in red and lined the box with dark figured cretonne.

The mechanical arrangement in the box is a flap of corrugated board attached to the bottom of the box with gummed paper tape which acts as a hinge. The box may be made of three-ply wood and the flap hinged on.

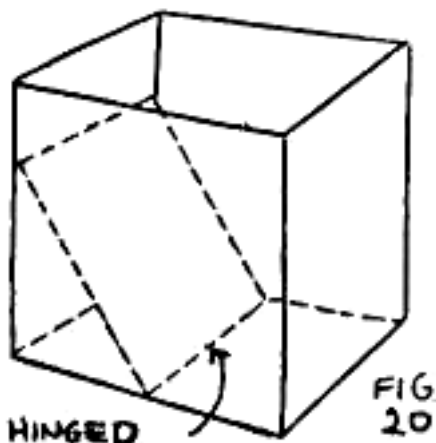


Figure 20 shows flap arrangement. It is shorter than the height of the sides of the box and is hinged across the middle of the bottom of the box.

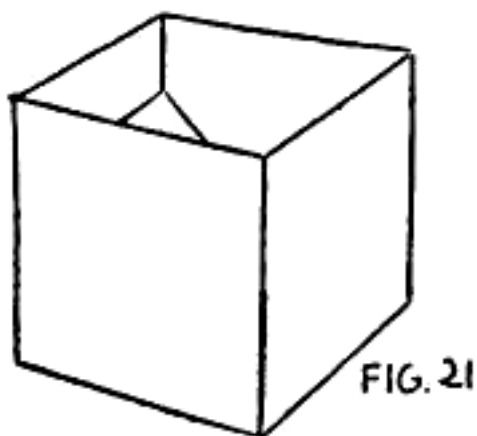


Figure 21 shows that flap cannot be seen from outside of box.

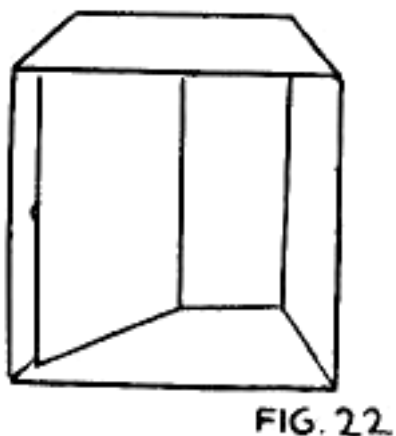


Figure 22 shows inside of box as you look directly into it. Box at this stage is not lined yet.

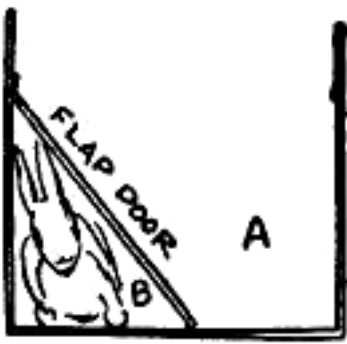


Figure 23 shows how a rabbit may be concealed in Compartment B. On each side of box is a hook on which to fasten flap when something is concealed in compartment on either side.

(30-26)

FIG. 23

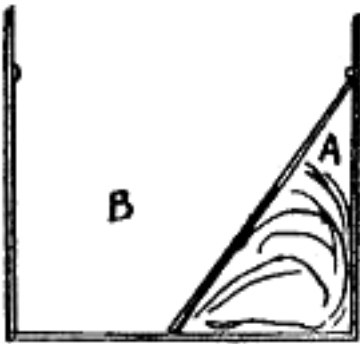


FIG. 24

When silks are dropped into box, flap can be easily swung to other side to enclose them in Compartment A and expose rabbit.

Figure 24.

To make the illusion more effective, cretonne is used to line the box and cover both sides of the flap. A dark-patterned cretonne confuses the eye so that when box is held up for a moment and kept in motion as it is shown empty, the box appears ordinary and empty. The illusionist has learned that proper cretonne is a great aid in some cases. To line the box, merely coat the sides and both sides of flap with glue and paste cretonne in.



FIG. 25

Figure 25.

To Perform:

Pick up box and keeping it in motion, show it to be empty. Replace on table or chair. You have rabbit concealed in Compartment B.

Produce silks from hat and lay them over front edge of box. Put hat aside. Pick up silks with one hand and box with other. Show box empty again quickly. Drop silks into box. Unhook flap and swing to other side to conceal silks. Hook flap quickly into place.

Pull rabbit out by the ears and hurriedly show box empty again.

* * * * *

A RABBIT TRAVELING BAG

In transporting small animals, such as the rabbit or guinea pig, it is well to have a traveling case for them. It is a great convenience in handling them.

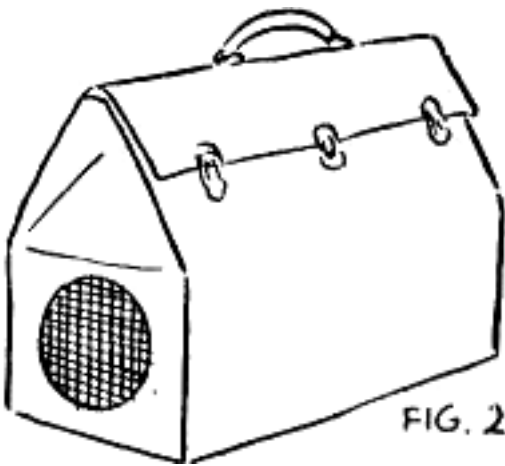


FIG. 26

Figure 26 shows a good bag. It is like a traveling bag but has an opening at one end with a screen over it for air. Animal stores usually carry various kinds of traveling bags for animals. You can have one made, however, in the repair department of some trunk shop.

* * * * *

DE LUXE SILK PRODUCTION FROM HAT

This is another silk production from a hat in which a large number of silks are used and then changed into a rabbit.

EFFECT:

A derby hat is shown empty, but in a moment, the Magician reaches into the hat and brings out silk after silk.

PARAPHERNALIA:

1 -- A number of large silk handkerchiefs and perhaps a thin silk scarf or two. Use brilliant colors.

2 -- A derby hat. Other kinds of hats may be used, but a derby lends itself better to the manipulation.

SECRET:

To Prepare:

This is worked with the Chinese Box. Prepare silks in a bundle as you did for the Silk Production from Hat described above. Take a piece of black thread and wrap it once around the bundle and tie. Leave about three inches at free end of thread. Tie this around a pin and insert pin in edge of brim of hat.

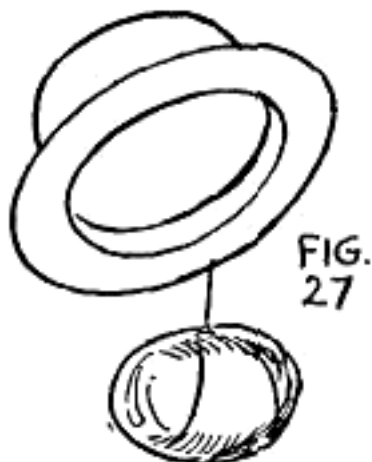


Figure 27.

If threaded edge of hat is held at top, bundle falls down into inside crown of hat.

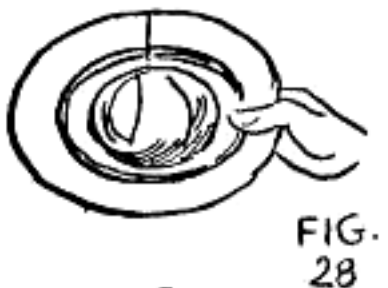


Figure 28.

To Perform:

Show back of hat to audience with bundle concealed inside of crown as in Figure 28 above.



Bring hat down to box. Turn it as you do so to bring threaded brim below. Bundle will drop out of hat and will hang by thread from brim of hat. Inside of hat can then be shown to audience as empty. Hold hat low enough to conceal bundle inside of box.



Figure 29.

Now turn hat forward and downward and let it rest across corner of box. Bundle is still inside of box suspended from rear brim of hat. Pull back sleeves a little, then pick up hat again from edge of brim marked A.

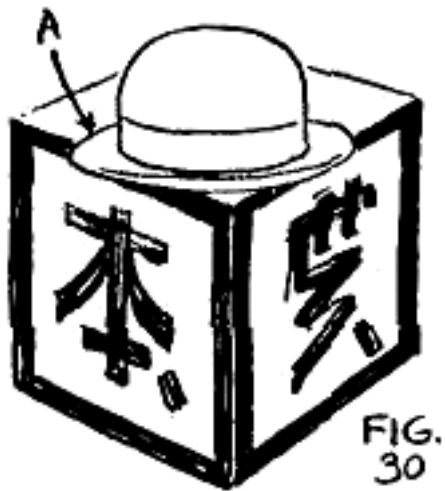


FIG.
30

Figure 30.

Raise rear edge of hat but keep front edge on box until bundle has been brought up inside of hat and is concealed. Tip hat forward until opening is upward. Reach in, unfasten silks, and produce them one at a time, laying them over a chair after you show them.

(30-28)

PRODUCTION OF RABBIT FROM SILKS

This is a good method for producing a good-sized rabbit.
EFFECT:

After producing a good quantity of silk from a hat or box, Magician picks up the mass of silk and calls attention to the fact that it is so bulky that it could never be put back into the hat again. Suddenly he discovers a rabbit among the silks and pulls him out, wiggling and squirming, from the mass.

PARAPHERNALIA:

- 1 -- A rabbit.
- 2 -- A chair, preferably of dining-room type. In emergency a folding chair can be used.
- 3 -- A special rabbit bag.

SECRET:

To Prepare:

The Chair -- Cover top of chair with a decorative drape to conceal it. It is easy to make a drape and put two small strings at two corners for trying it on -- or it may be tacked on with a few thumb tacks.

In the center of the back of the chair, drive a four-penny nail. Have it slant upward and far enough out from chair so that you can hang a bundle on it securely. Some performers prefer using a nail without a head or with a very small head to speed up working.



FIG. 31

Figure 31.

The Rabbit Bag -- I shall explain here the Four-Ring Rabbit Bag, and farther on I shall tell you about other types of Rabbit Bags.

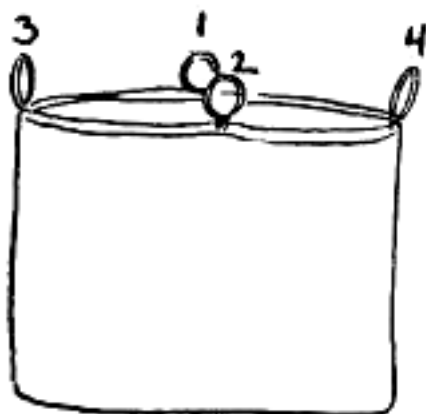


FIG 32

The Four-Ring Bag is very simple. Just make a bag of dark-colored cloth, large enough to hold the rabbit. Hem the top well so that four rings can be sewn securely into place -- one at each end and one at each side. When the rabbit is put into the bag, feet down and head up so that he rests easily, pull the rings together in this order: first, 1 and 2, then 3 and 4. All four rings are thus ready to slide over nail on back of chair. Have rings about an inch in diameter so that finger can be inserted in sliding off nail.

Figures 32 and 33.

(30-29)



FIG. 33



FIG.
34

For comfort of rabbit, sometimes a pasteboard bottom is placed in bag. Frank Caesar, a prominent Magician, sometimes uses a tin or china plate in bottom of bag for rabbit to sit on – then before or after producing the rabbit, he produces a plate for him to sit on.

Figure 34.

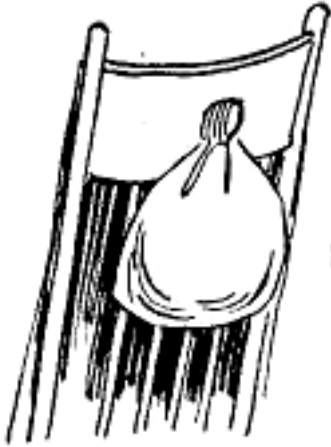


FIG.
35

Figure 35 shows Rabbit Bag arranged on back of chair. This is turned away from audience so that they cannot see it.



FIG.
36

To Perform:

After you have produced silks, spread them over top of chair. They will fall behind and over top part of Rabbit Bag.

Figure 36.

As you remove silks from chair, insert second finger of right hand into rings of Rabbit Bag and slide them off nail. Raise Bag up under cover of silks and come forward with it.



FIG.
37

Figure 37.

Remark about the difficulty of getting so many silks back into the hat again. Look at silks a moment.

Grasp Ring No. 1 through the silks with left hand and release other rings from right hand. The bag falls open. Reach in with right hand, grasp rabbit securely by the ears, and bring him out.

Figure 38.

Show rabbit to audience. The silks in left hand conceal the rabbit bag. Drop silks and place rabbit over left arm. Pet him a bit so that children in audience can get a good look at him.

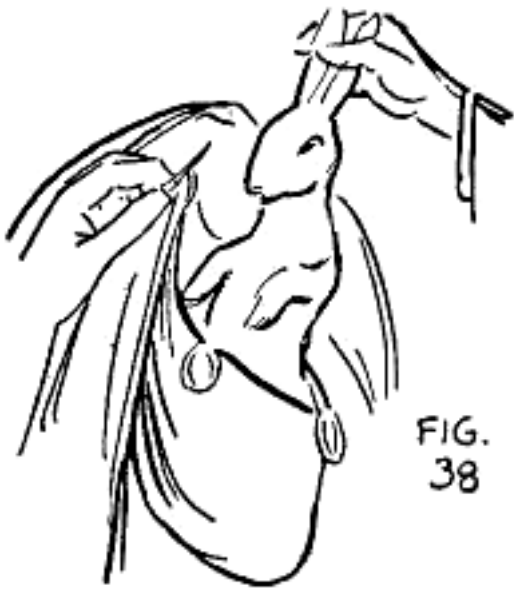


Figure 39.

* * * * *

CHINESE BOX VANISH FOR RABBIT

Have the Chinese Box loaded with candy kisses (candy wrapped in paper) in place of silk load. Have a good quantity of these kisses.

(30-30)



Pick up box and show it empty, then replace on table. Show bunny, holding him by the ears, and then drop him into box. Swing flap over and hook into place to conceal bunny.

Pick up box and pour the candy kisses out into a bowl. Then show box empty. Distribute candy to children.

Figure 40.

* * * * *

OTHER RABBIT BAGS:

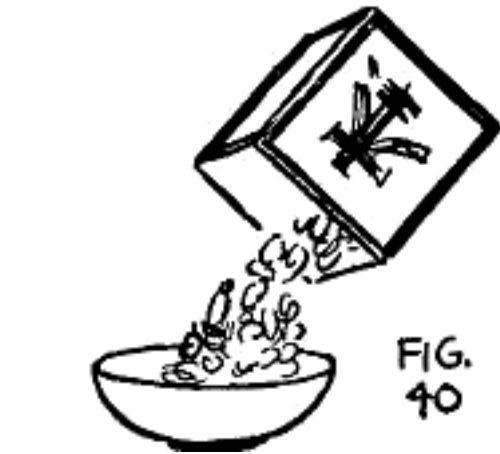


FIG. 40

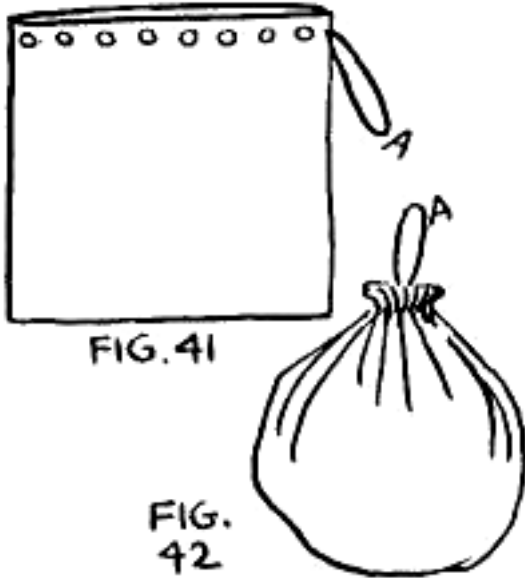


FIG. 41



FIG. 42

The Loop Rabbit Bag: Figures 41 and 42 show the bag. The top is hemmed well. Round holes are then cut in the top an equal distance apart. These holes are buttonhole stitched to keep from raveling. At one end a loop of tape or shoe string is sewed on securely. Rabbit is placed in bag. Loop A is then threaded through the holes all around the top of the bag back to the starting point. This serves as a drawstring.

When top of bag is drawn together, bag can be hung on nail at back of chair by the loop. When bag is removed from nail and loop released from fingers, the bag opens easily. The loop need not be very long. You can best determine the length for yourself by finding the most convenient length for you.

Another bag similar to this one has, instead of holes cut into it, small rings sewed along the top about an inch and a half apart. The loop is passed through these rings.

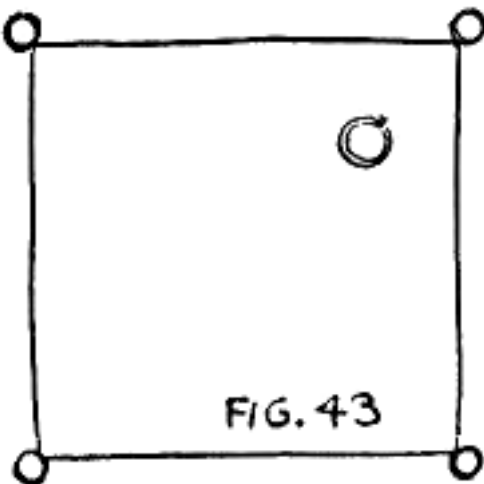


FIG. 43

The Handkerchief Rabbit Bag: Figure 43 shows the construction of this bag. It is made from a black or dark-colored handkerchief. A ring is sewed at each corner and a larger one a few inches from one corner.

Rabbit is placed in center of handkerchief on side opposite from ring. The four corners of handkerchief are pulled up together. The four corner rings are then passed through the larger ring. Push larger ring down around rabbit to keep him secure in bag.

Figure 44.

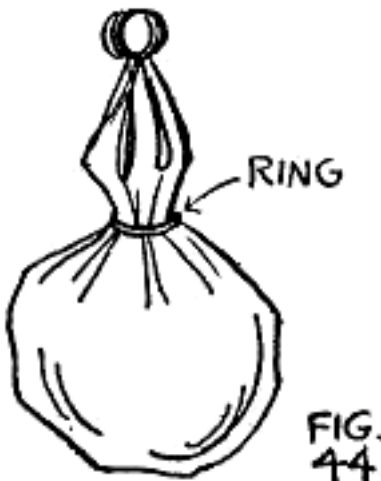


FIG. 44

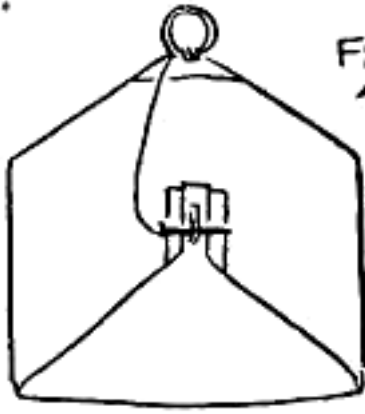


FIG.
45

The Flap Rabbit Bag: Figures 45 and 46 show this bag. It has a flap on bottom which folds up and is held in place with a simple catch made of leather. Part of this catch is sewed to bag proper and part to flap. A nail secures the catch. Nail is tied to ring at top with piece of string to keep it from falling down when it is removed from catch.

(30-31)

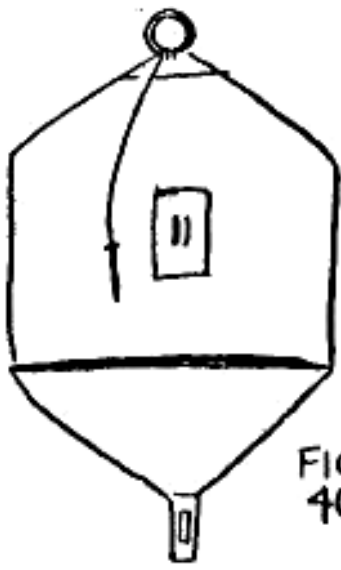


FIG. 46

The ring at top goes over the nail on back of chair. This bag is most used for a quick production of pigeons or a duck. When catch is released, flap falls down and out come the animals.

It is also good for production of candy kisses when there are children in the audience.

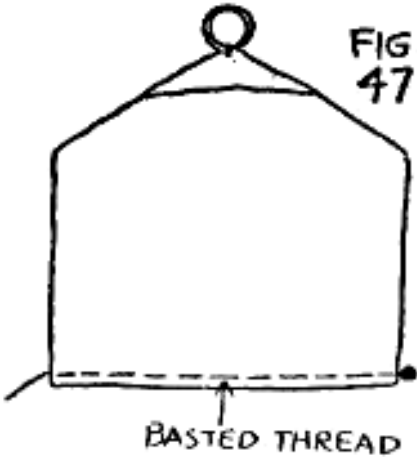


FIG. 47

The Basted Bottom Bag: Figure 47 illustrates this bag, which is also most often used for quick production of doves rather than rabbits. Make a cloth bag like the illustration with a ring at top. Put animals into bag with open bottom. Then attach a small button to a thread and baste bottom of bag, leaving a few inches of thread at free end. When ready for production, merely grasp button and quickly pull out basting thread. This opens bottom of bag and releases animals.

Harlan Tarbell

TARBELL SYSTEM, INCORPORATED, Chicago.

LESSON 31

Another very interesting lesson on SUPERMENTALISM AND MIND READING. More effects and more methods in this fascinating division of Magic. When you have studied this lesson, you will be very thoroughly informed on these subjects and can give Mind Reading Acts which will make a reputation for you.

LESSON 31

Today's lesson gives you more of the principles of Mind Reading and Mental Magic.

These are the three fundamental things in producing a Mind Reading Act:

- 1 - To obtain in a secret manner what a spectator wants to know.
- 2 - To answer the spectator to his complete satisfaction so that your remarkable ability impresses itself on his mind.
- 3 - To present the work in so interesting a manner that it holds attention, makes a strong impression, and is long remembered.

There are various methods by which the Magician can determine what the spectators write. In Lesson 29, you were taught the Carbon Method. In this lesson, you learn other methods. You may choose the method which best suits your personality. A performer, however, must be prepared to meet emergencies or varying conditions under which he works. Sometimes you will work with an assistant, sometimes without. Sometimes you will work on a stage, sometimes in a club or parlor. It is therefore necessary that you master several methods of producing Mind Reading Acts so that when occasion arises you are prepared to meet it by switching from one method to another without being detected by your audience.

In answering your spectators' questions, you must be POSITIVE and CONVINCING. Talk distinctly and loud enough to be heard by everyone. Talk directly to your spectators so that they are convinced that you mean what you say. Drive your points home. Beware of anything half-hearted or apologetic. Keep using the POWER OF SUGGESTION and let nothing creep in to destroy your audience's conception of you as a Super-Mentalist.

To create INTEREST, your work must be highly entertaining. Introduce Comedy at proper places, even if you have to use an occasional "fake" question. Pretend that a certain question or problem was put to you and have a funny answer ready. Look at the audience without concentrating on any certain spectator so that no one person will think you spoke directly to him. Some powerful effects can be produced this way. When you are seriously answering questions, strive always to do so in the most interesting manner possible. Make your act so interesting that people will want to see you again and again and will talk about you so much that others will want to see you --and so on until your success artistically and financially is assured.

An ingenious yet simple method of working which appeals to many.

EFFECT:

Performer passes out blank cards, envelopes, and pencils to audience. Spectators write any question they desire answered or numbers on coins or bills, telephone numbers, addresses, etc. on the cards. They then seal the cards into the envelopes. Envelopes are collected and placed in a glass bowl on table in center of stage. Magician takes a crystal ball and gazes into it. Then he begins to read off questions and answers them. He names numbers written, etc.

PARAPHERNALIA:

- 1 -- Blank cards, size of ordinary visiting cards, about 2 x 3 1/2 inches.
- 2 -- Manila pay envelopes, large enough to hold the cards and opaque enough so that writing on cards will not show through.
- 3 -- Pencils, fairly soft lead.
- 4 -- A crystal ball with small pedestal.
- 5 -- A special book for question reading.
- 6 -- A special collection basket.
- 7 -- A glass bowl.
- 8 -- Small table or stand.
- 9 -- A pair of scissors.
- 10 -- Other accessories according to requirements of the Act you are presenting.

SECRET AND PRESENTATION:

To Prepare:

Cards and Envelopes:

You must prepare duplicate cards and envelopes for those which you pass out to audience. If you pass out three dozen cards to audience, take another three dozen, seal them into as many envelopes, and place in the sides of the specially prepared collection basket. If you prefer, you may use just sealed envelopes without cards.

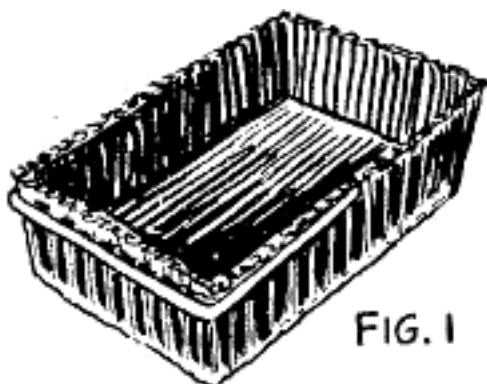


FIG. 1

Special Collection Basket:

To the audience this basket looks like a decorated basket. It is in reality, however, a cleverly constructed piece of apparatus used for exchanging envelopes placed in it by audience for duplicates prepared by performer.

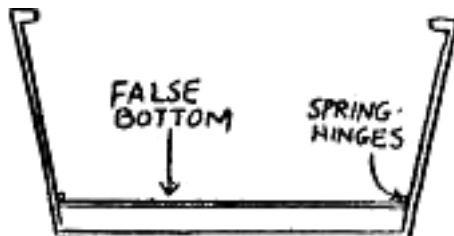
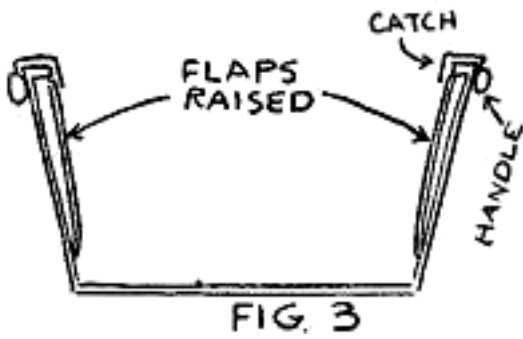


FIG. 2

Figure 1.

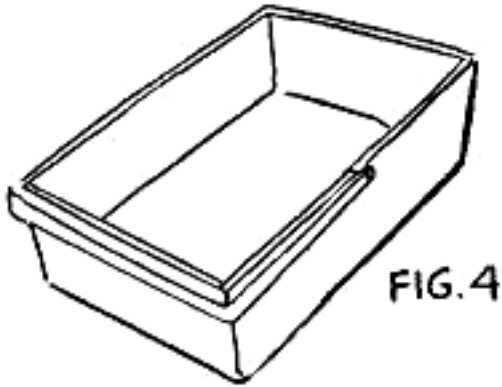
The basket has a false bottom of two pieces, each being spring-hinged to the sides about one-half inch up from real bottom of basket.

Figure 2.



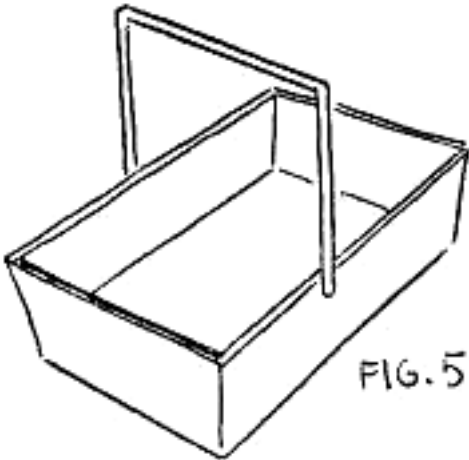
Each part of false bottom swings up against the sides of basket and is held in place by catches just under the handle of basket, which is across the middle of it.

Figure 3.



When handle is dropped down, catches hold parts of false bottom up against sides of basket.

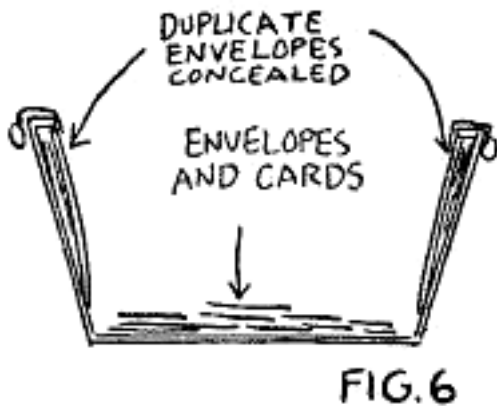
Figure 4.



When handle is raised, catches are released and parts of false bottom fall into place.

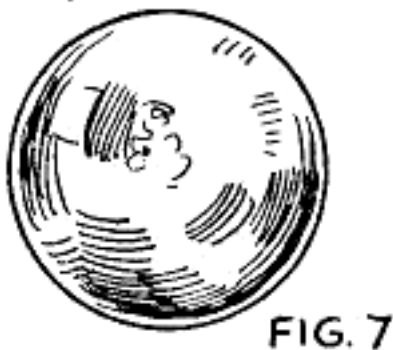
Figure 5.

This basket is usually made of reed and lined with satin to make it decorative and to conceal the mechanism. The basket which I use is made by an expert and is like the one described above. It is much better to have it built by an expert than to try to construct it yourself. This basket is much better than the usual "spirit basket" as there is more room in it for concealing questions. You will find this basket very valuable to you for it has many uses. The School is glad to supply you with this basket at a very reasonable rate.



To prepare for your performance, divide the duplicate envelopes. Place one-half of them on one side of false bottom and other half on other side. Swing two sides of false bottom up and secure with catches by lowering handle. In the real bottom drop same number of cards and envelopes and pencils, ready to be passed out to audience.

Figure 6.



Crystal Ball:

The crystal ball is just a round glass ball and not the expensive kind. It is used merely for effect and has no magic properties so the quality of it does not matter. You merely lead spectators to believe that you see visions in the crystal, and it also serves to MISDIRECT attention of audience.

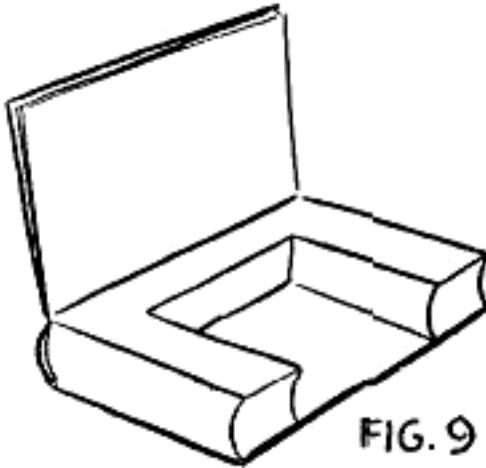
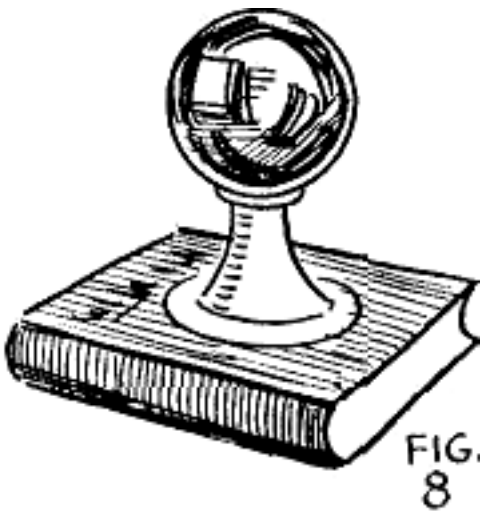
Figure 7.

The crystal has been associated with clairvoyants and psychics for many years. Many people study crystal gazing seriously, hoping to reach the stage where they can see visions and foretell future events in the crystal. If anyone has ever seen mental pictures or future events in a crystal, it is because he stretched his imagination and not because he actually saw them. I hope you will never take the crystal seriously. It is merely an accessory to give suitable atmosphere to your work.

Mystic Book:

This book looks like an ordinary book, on which you place pedestal with crystal ball.

Figure 8.



It is prepared, however, in this way:

Take book of fair size--about 5 1/4 x 7 1/2 x 1 1/4 inches. With sharp knife, cut away part of the book as shown in Figure 9.

Do not cut the first two and last two pages in the book. Cut a few pages at a time until you have cut them all.



Close book. Turn prepared side away from audience and they will never suspect the book of being prepared.

Figure 10.

The space in the book is for concealing cards which spectators have written. As you pretend to gaze into the crystal on the book, you slip out the cards a little and read them.

STAGING THE ACT:

The Act may be presented from many angles. It may be given Hindu, Chinese, Persian, Egyptian, or Modern dress. Decide on the manner in which you want to present it, and have your settings and costume bear out the part you are playing. If Hindu, use a Hindu costume and have your stage settings of Hindu design. Sometimes the burning of incense helps to create suggestive atmosphere. If you make the act Modern, wear dress, tuxedo, afternoon, or business suit. The cutaway coat and striped trousers make a dressy set.

To Perform:

Have collection basket ready with cards and envelopes and pencils on table. Crystal ball and mystic book are offstage.

Here is a suggestion for your introductory speech, which you should vary to fit in with your style of presentation:

"Ladies and Gentlemen: Down through the ages men have been interested in Mind Reading and the foretelling of events through mental power. As a result, an amazing number of clairvoyants, fortune tellers, spirit mediums, astrologers, mind readers, psychics, and what not, have arisen, claiming supernatural power.

Science has established, however, that those things which seem to have a supernatural aspect are merely natural

phenomena. What at one time appeared to be superhuman is now recognized as merely mental development. Modern research has brought about astonishing revelations with regard to human mental power. It has shown that we all possess similar mental powers but that these powers vary greatly in development. Some by inheritance and development are strong in the artistic, others in the mechanical, others have peculiarly strong development of mental powers.

"The discovery of the radio has awakened startling realizations. You sit in the privacy of your home, and by the mere turning of a knob, you bring in music and programs from cities hundreds of miles distant. It seems hardly possible, yet it is so. Imagine the effect if several hundred years ago you could have introduced a modern radio, or even a phonograph for that matter! The people would have believed that you had supernatural power and brought the voices and music from some distant planet. They would have believed that they heard spirit voices or the singing of angels.

"Now that we understand the wonders of the radio, which is just a piece of mechanical construction, we stop to think of the even greater wonders which might be accomplished by the human mind when it is properly attuned. We have all had odd mental experiences. The phone rings and we instinctively feel that it is Aunt Mary calling, and, sure enough, we answer and it is Aunt Mary. We get a mental 'hunch' of something which is going to happen. This is an example of being mentally attuned.

"These things have interested me for some time, and I have experimented with mental reactions. Some of these experiments I want to present to you this evening, not as a fortune teller or clairvoyant, but just a regular human being dealing with scientific and impressionistic problems. I have found many interesting things about your mind and my mind, and if you will follow carefully what I say, we can uncover some interesting phenomena. My success depends on your willingness to help. Some people try to do the opposite from what you tell them so as to trick the performer. This is the same as telling these people to turn to Number 50 on their radio and they will hear New York and having them turn to Number 80 instead. Of course, they can't get New York because they didn't follow instructions, and then they say, 'There! I knew you couldn't get New York!' There is nothing magical in radio messages, nor is there anything magical in mental messages. You must follow the law to get results.

"The first thing necessary is for you to concentrate. So many things run through our minds that to keep our minds on one certain subject seems almost impossible sometimes. For this reason, I am going to have you write your mental message. The process of writing impresses the message on the mind. Many times writing is not necessary when a person has developed great powers of concentration and is in a quiet place. In an audience, however, writing proves to be the most effective way of concentrating. I will pass out cards, envelopes, and pencils. On the card write your message distinctly and carefully to impress it on your mind. Then seal the card in the envelope.

"Now, as to what you should write. Perhaps you would like to ask a question - perhaps some problem is bothering you. But remember, no foolish questions - for they have foolish answers. Perhaps you would like to write the date of one of your coins, the number of a bill, your telephone number, the name of your watch, the name of a great event and when it happened, - or if you like, you may draw a simple picture or design like a circle, a square, a triangle, or such. At the bottom of the card write your name - then seal the card well in the envelope."

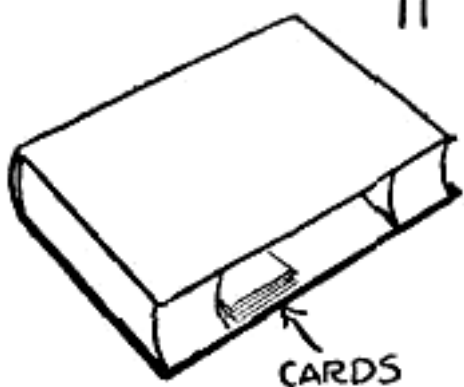
Take up the basket and pass out cards, envelopes, and pencils. Distribute them over the house. Give a card, an envelope, and a pencil to a person. As you move about audience, keep up a running talk about what spectators can write or draw and about sealing cards in envelopes, etc.

After sufficient time is allowed for writing, collect the envelopes in the basket and the pencils in your hand.

As you go back to stage, raise handle of basket. This causes false bottom to fall into place, covering spectators' envelopes and exposing your duplicates. Be careful that no one can see into basket. Walk over to table on which is standing a glass bowl. Pour out envelopes from basket into glass bowl, holding opening of basket toward audience to show that basket is really being emptied. Casually place basket offstage.

Assistant helping you takes the basket offstage, opens the false bottom, and pours envelopes with cards out on table. With sharp scissors, he quickly cuts open ends of envelopes and takes out a dozen or so cards - the number depending on the length of your act.

FIG.
11



Assistant arranges these cards, with writing uppermost, in a little pile and places them in left side of mystic book. He places this book and the crystal and pedestal in a handy place for you offstage.

Figure 11.

After you place basket offstage, there is a wait while assistant prepares cards. I suggest the following to fill in the time:

RAPID MENTAL TRANSFERENCE

EFFECT:

Performer shows a card, an envelope, and a pencil. He gives card and pencil to a spectator with request to write any number between one and a million. Card is then sealed into envelope. Spectator is asked to concentrate on his number. Performer takes pencil and in a moment writes spectator's number, digit by digit, on the envelope. Card is then removed from envelope and the two numbers shown to check.

PARAPHERNALIA:

- 1 -- A blank card like a visiting or business card, about 2 x 3 1/2 inches.
- 2 -- An opaque manila pay envelope, about 3 1/4 x 4 3/4 inches.
- 3 -- A pencil.

SECRET AND PATTERN:

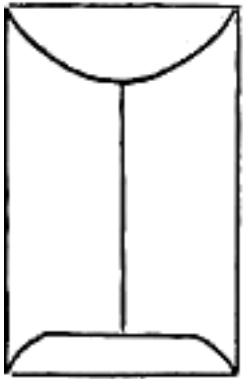


FIG. 12

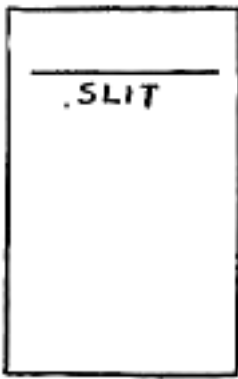


FIG. 13

To prepare:

Take the envelope and insert in it a piece of cardboard. This is done so that when you cut a slit in the front of envelope, the back or seamed side will not be affected. Cut your slit about 1 1/8 inches from flap end of envelope. Cut it to within about half an inch from sides of envelope. Remove cardboard. If slit is made with a very sharp knife or razor blade, it will not be noticeable when envelope is shown hurriedly. At a distance of a few feet from spectators, slit is not visible at all. However, be on your guard so that slit is not exposed.

Figure 12 and 13.



FIG. 14

To Perform:

Come forward with prepared envelope, card, and pencil. Hold pencil in right hand. Hold envelope in left hand with slit side down on palm and flap side up. Have card on envelope.

Figure 14.

"Before beginning work in mental transference, I usually make a test at rather close quarters to determine harmony of thought. Audiences vary just as radio conditions vary. One night you hear a station very clearly, and the next night you perhaps can't even get that station."

Come down close to audience. If performing on stage, stand on the runway or steps.

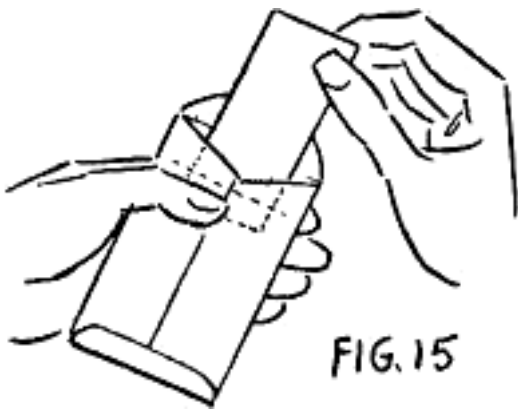
"Will you, sir, be kind enough to help me? I believe you have good power of concentration. Please take this card and pencil and write down any number between one and a million. I suggest that you write a number of three or four digits, though, of course, you have your own free choice. Do not let me see the number -- keep that side of the card hidden from me."

Spectator writes number on card.

"And I shall ask you to place the card in this envelope."

Show slit side of envelope by taking it in right hand and then replacing in left. Slit will not be noticed. Envelope held in left hand in position shown in Figure 14 makes it easy for spectator to insert card without noticing slit.

"Keep the number side of card downward and away from me and just slip the card into this envelope."

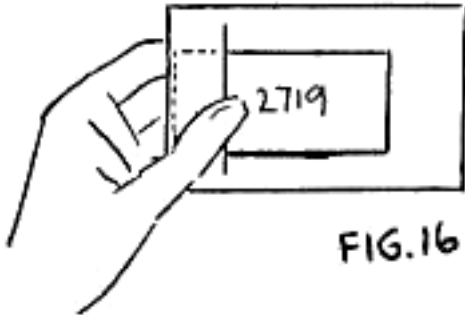


As he places card in envelope, guide it so that it goes through the slit and most of the card is between left palm and envelope instead of inside.

Figure 15.

WARNING:

Watch your Angles of Visibility. Make sure that no one can see the card outside of envelope. Hold it close enough to you and stand far enough away from spectators to cover card well.



Seal flap of envelope and hold envelope in position shown in Figure 16. This exposes numbered side of card and enables you to read it at a glance. Do not keep your eyes on envelope but glance at it very quickly and look up again at spectator who wrote number. As you talk to him, allow envelope to slip back on palm of left hand again.

"You have written a number, sir, of your own free choosing -a number somewhere between one and a million. I have had you write it on this card so that you may the better concentrate on it. Will you, sir, think of your number one digit at a time, starting with the first? That's fine! I sense the number TWO. Is that right, sir. It is."

Write the number 2 on the envelope.

"Now, the next number. SEVEN -- right? SEVEN."

Write 7 next to the 2.

"The next -- that's right, concentrate hard. ONE correct? You are doing fine, sir."

Write 1 after the 7.

"Again -- the next number. NINE -- right? Down goes the NINE."

Write 9 after the 1.

"Now, try it again. Oh, there isn't any more -- that's all there is. All right, then. The number is -- two, seven, one, nine. Let us check up."

Tear open flap of envelope, reach inside with right hand and draw out card, part of which must still be in envelope. Show numbered side to audience and read card.

"Two -- seven -- one -- nine."

I suggest using numbers, but names could be written and spelled out letter by letter.

BY THIS TIME ASSISTANT SHOULD BE READY FOR YOU AND YOU CAN PROCEED WITH YOUR MIND READING ACT.

Step to side of stage. Place card, envelope, and pencil offstage and take the crystal ball, the pedestal, and the mystic book. Keep book horizontal so that you will not disturb arrangement of cards and keep opening to rear.

Place book on table and the pedestal on the book. Hold crystal ball in left hand and offer this explanation for using it.

"The crystal has long been associated with mental and occult phenomena. Men have bought fine crystals valued at hundreds of dollars in the hope of seeing something in them to foretell the future or read men's thoughts. To me the crystal is a means of helping me to gain intense concentration and to attune my mind to outside forces."

Place crystal ball on the pedestal on book. Sit down in chair placed a little behind table. Gaze at ball, and as you do so, slide out a card from book with hand. Pull it out just far enough to glance at it. Continue to look at ball and slide card to right side of opening in book. You can still glance at it if you need to, and it is now out of the way of the next card. Now look at audience.

"Concentrate on the thing you want me to tell you Concentrate on what you have written. When I call out your name, please raise your hand. Just as in radio, I cannot tell where messages are coming from. If you will let me know just where you are, I can work directly with you."

Suppose the first card has on it this message:

X16526518B

Thomas Coleman.

You know that this is a number on a bill. The letter on the end tells you that, for bills come in lettered series.

"Ah, here is a message from T. C. Who signed himself with T. C.? Thomas Coleman is the name. I get, Mr. Coleman, that you want me to tell you a number on a bill which you have. If you have the bill handy, will you please take it in your hand and concentrate on the numbers one at a time? Are you ready? X-1-6-5-2-6-5-Seven, no, that isn't right -- it's a 1 -- the next is 8 -- the letter is B."

Continue working this way with the other cards. You should have no trouble in getting your information from the cards without being detected. If you find one card which gives you a chance for good SHOWMANSHIP, hold it back for the closing number and come out strong with it. To answer this feature card, stand up, take crystal from pedestal and come down front with it - then answer it. Should someone draw a picture, draw a duplicate of it on a piece of cardboard with black crayon to make an effective finish for your act.

SUGGESTIONS:

1 - If you are working under conditions where there are no other acts backstage and assistant has full free-

dom, you may use this clever plan for getting information.

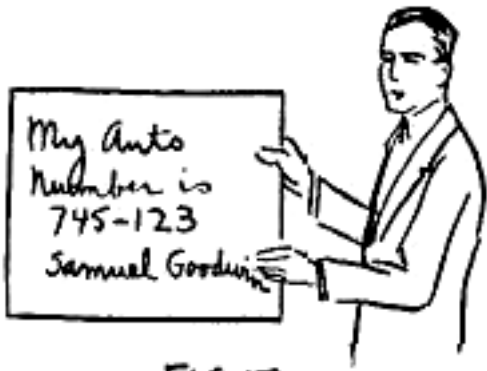


FIG. 17

Have assistant copy cards onto large cardboard with heavy crayon. He then stands at right front of stage back of wings and holds up cardboards for performer to read.

Figure 17.

Be careful that assistant cannot be seen by audience. A glance or two will convey the information to you. and you can hold the crystal ball and move about on the stage while answering questions and giving out information.

2 - Another ruse is to take a piece of black velvet about twelve inches square. With a smaller piece of black velvet, make a pocket in one corner of large piece. This should be large enough to hold cards and allow room for sliding them to side out of way. Pocket should be on under side.

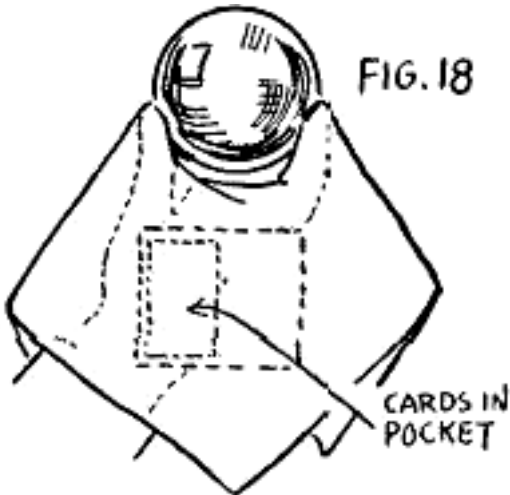


FIG. 18

Place piece of velvet over left hand and grasp crystal ball through it in left fingers. Under cover of velvet, raise a card up with right hand and glance at it, then slide it to right side of pocket out of the way. Keep eyes apparently on crystal all the time.

Figure 18.

3 - Crystal ball may be eliminated and the tablet idea substituted as taught you in Lesson 29. This merely requires copying the cards onto a tablet.

* * * * *

A GOOD "ONE MAN" MIND READING ACT

This act requires no assistant and is adapted to both stage work and close work.

EFFECT:

Performer passes out small slips of paper and pencils with the request that spectators write questions, etc. (as in other Mind Reading Acts). Papers are folded, collected, and placed on table. Performer picks up a tablet and pencil to help him get mental impressions. Then he picks out one of the slips of paper and puts it aside. He writes down his impression of the message contained on this slip of paper. If it is a question, he answers it. The slip of paper is then unfolded, and the message in it is found to check up with the performer's impression. Paper is refolded and passed down to owner. Another slip is picked out and the same routine carried through with it, and so on with as many slips as performer has time to handle.

PARAPHERNALIA:

- 1 -- Slips of paper, 2 x 2 1/2 inches.
- 2 -- A glass bowl or plate for collecting slips.
- 3 -- Pencils, fairly soft lead.
- 4 -- A commercial size tablet, 8 1/2 x 11 inches. Remove cover from tablet.
- 5 -- A candlestick and candle.

SECRET AND PATTERN:

To Prepare:

Cut a slit in top of candle large enough to hold a folded slip of paper.

Fold each piece of paper in four, crease it well. Mark a small number with pencil in the corner of each slip, starting with 1 and continuing upward. Open slips again. The purpose of folding them beforehand is to have spectators use the same folds and thus have all slips uniform in appearance.

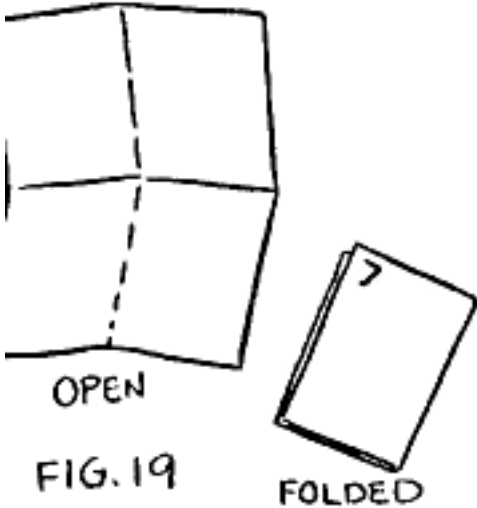


Figure 19.

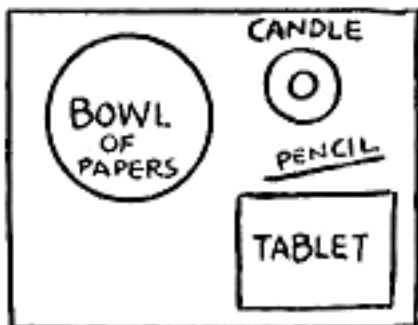
Have slips on plate or in glass bowl with pencils. Have tablet and pencil ready.

To Perform:

Your opening speech may be like the one used in the Crystal Gazing Act.

Pass out papers and pencils to audience and request that they write questions, numbers, dates, etc., and sign their names to slips. Tell spectators that each slip is numbered and that they should fold their slips so that number is on the outside. Tell each to remember his number.

Collect slips on the plate or in the glass bowl and take up pencils. As you return to stage and your back is toward audience, reach up to plate with right hand and palm one of the slips - using either Finger Palm or Front Thumb Palm method. Keep back of hand toward audience. Notice number on slip of paper if you can. If not, you can get it later. Let us say it is No. 8.



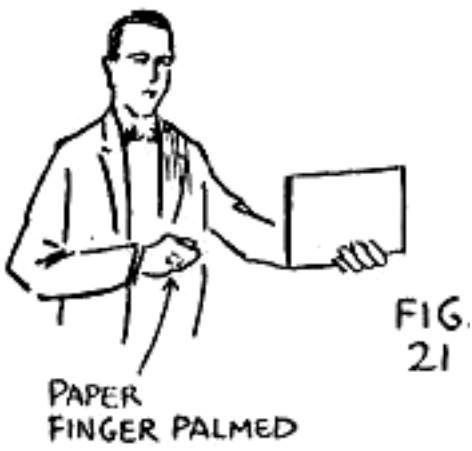
REAR OF TABLE

FIG. 20

Place bowl or plate with slips on table. Have table arranged as shown in Figure 20.

Pick up tablet with left hand. Turn to face audience, holding tablet as shown in Figure 21. Fingers are in front and thumb in back of tablet.

(31-11)



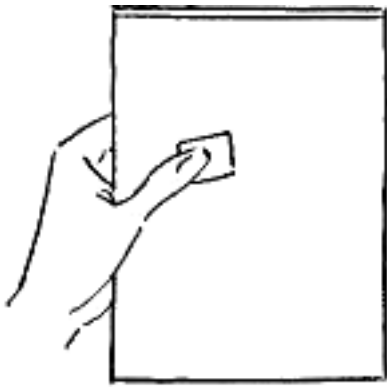


FIG. 22

With a natural movement bring right hand back of tablet and place slip of paper under left thumb.

Figure 22.

Then continue movement of right hand over top of tablet to reach for pencil on table.

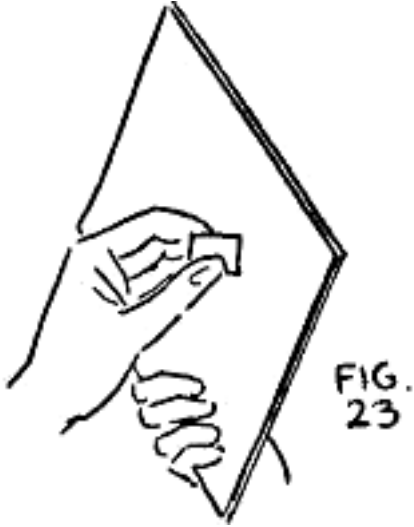


FIG. 23

With pencil in right hand, grasp bottom edge of tablet, releasing left hand with slip of paper. Keep left hand screened by tablet.

Figure 23.

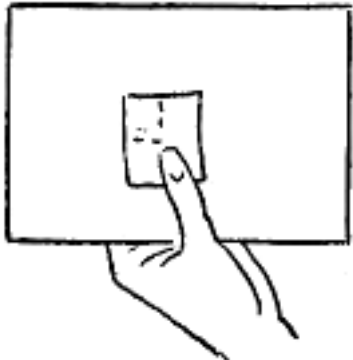


FIG. 24

With left fingers open slip of paper and hold it pressed against back of tablet with left thumb. Grasp bottom edge of tablet again with left fingers. Right hand with pencil is now released.

Figure 24.

"Not only do I find that having you write your thoughts helps me to catch them, but also I find that if I write myself, it enables me to concentrate better and to tune in more readily to outside impressions."

REAR VIEW

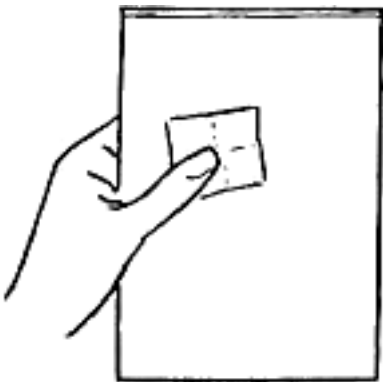


FIG. 25

Scribble hurriedly on the tablet and hold it up to audience, always keeping back of it with slip of paper toward yourself. This brings tablet up and slip of paper in your line of vision. Quickly read message on slip.

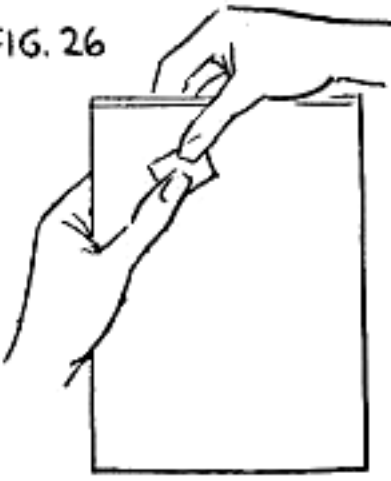
Figure 25.

Bring tablet down again toward your left. Grasp bottom with right hand and quickly fold slip with left hand. Quickly bring left hand back in position again, thumb holding slip on back of tablet and fingers in front at bottom edge.

As you do this, you must keep up your patter to MISDIRECT attention. Say something like this:

"This isn't spirit writing, however. Somehow, the spooks have never been so communicative with me as to jump around on my paper."

FIG. 26



Turn tablet upright again, forcing slip upward with left thumb. Grasp tablet at top with right hand, fingers in front and thumb in back. Push slip up under right thumb.

Figure 26.



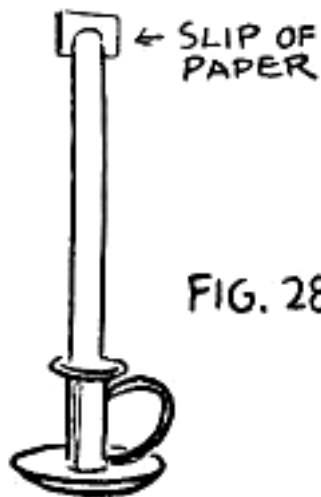
Drop tablet to right side, being careful to keep back concealed. Reach over and take folded slip of paper from plate on table and hold it up in left hand.

Figure 27.

(31-12)

Notice number on this slip -- say it is 21. The slip you already have is No. 8.

"Will No. 8 please concentrate for a moment? Fine! I get an impression from K. R."



Place slip in slit at top of candle. Audience thinks you are getting impression from this slip. In reality, you are giving message from slip you have in right hand behind tablet.

Figure 28.

Pretend to write impressions as you call them out. Under cover of tablet FINGER PALM slip in right hand. As you hold pencil in right hand also, it helps to conceal slip.

Suppose the message reads:

Will our house be finished by September?

Mrs. Karl Richmond.

"K. R., where are you? Mrs. Karl Richmond. That's it, hold up your hand. You want to know something about a future event. It has something to do with building. I get an impression of a home in process of construction. Is that right? Are you thinking of a home which you are building? What's the matter? Do you want to get into it by September? Just keep in touch with the contractor. He can push ahead or delay, and your contact with him will help you get action. I believe I got your mental impression all right."

Pick up slip from candle with left hand. Place tablet and pencil at rear of table with right hand. Bring hands together and open up folded slip. Read the message to yourself. Perhaps it is this:

Tell me my telephone number-- Main 684-J.

William K. Smith.

Pretend that you are reading Mrs. Karl Richmond's message.

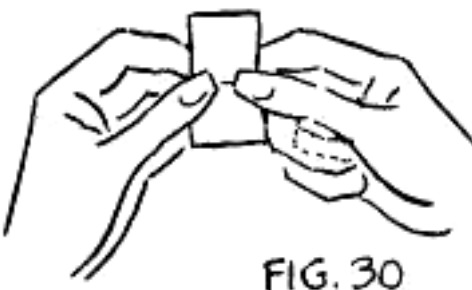
"That's right. You wanted to know about finishing your home in September, as I said."

THE MOVES OF UNFOLDING AND FOLDING SLIPS ARE VERY IMPORTANT:

Study these movements very carefully. Do not go any farther until you have mastered them.



After you have picked up folded slip from table, hold it in position shown in Figure 29.



Push left thumb between folds of slip and push up rear part.

Figure 30.

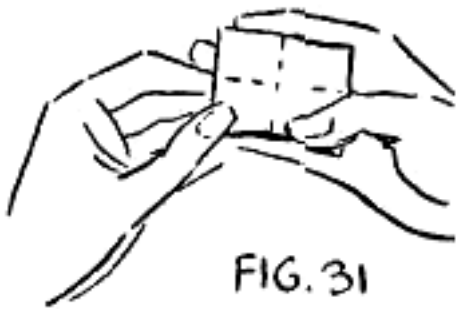


FIG. 31

Now open slip completely. Open right hand and slide open slip into right hand so that it covers the Palmed folded slip.

Figure 31.



FIG. 32

Fold slip again by pushing over left side of it with left thumb. Then fold over top part to the rear, pushing it down with right index finger. Press slip down on slip in right palm, apparently to crease it well. Take both slips pressed together between thumbs and forefingers of both hands. Show freely as one slip, exposing palms of hands to audience.

Figure 32.



FIG. 33

Now hold slips pressed against first three fingers of right hand with right thumb.

Figure 33.

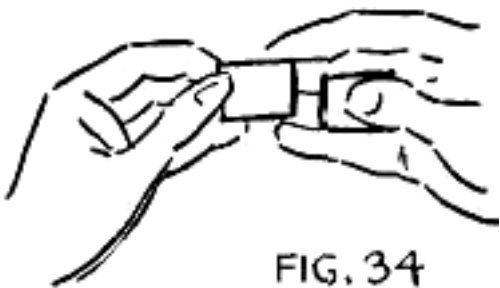


FIG. 34

Right thumb draws top slip back into hand, ready for Finger Palming. This slip is No. 21. Left hand takes under slip which has been Finger Palmed all the time away from right hand. This slip is No. 8, a message on which you just read.

Figure 34.



FIG. 35

Drop right hand to side. As you do so, curl three fingers of right hand inward and FINGER PALM slip. Keep back of hand to audience.

Figure 35.

Return slip in left hand -- No. 8 -- to spectator who wrote it.

"I will just return the paper to the owner so that she may keep it as a souvenir."

Step down to audience far enough to hand slip to someone and ask him to pass it along to Mrs. Richmond. In some cases, if owner is near enough to you, you may deliver the slip personally.

Go back to table and pick up another slip of paper. Suppose it is No. 19. Call out number of slip palmed in right hand.

"Number 21, Number 21 -- where are you?"

Place this slip in slit of candle. Pick up tablet and pencil again and pretend to write impressions.

"I get an impression from W. K. S. Concentrate, Mr. Smith. You want me to tell you what your telephone number is. If I had a telephone book here, it might be easy. Isn't your first name, William? William K.? Think of your number, please -- first the exchange. Main -- isn't that right? Now the numbers -- SIX, EIGHT, FOUR, J. Main 684J."

Lay tablet and pencil on table again and pick up slip No. 19 from candle. Open it as before and pretend to check up on Mr. Smith.

You now go through routine of folding slip and exchanging it for palmed slip in right hand as taught you above. See Figures 29 to 35.

Return slip No. 21 to owner.

Pick up another slip - say, No. 7. Do not use tablet from now on except to accent a point or draw a picture. As you pick up each slip, call out the number of the slip palmed in right hand. In each case, tell spectator your impression or answer his question, then go through routine of opening slip apparently to check up but really to read next message. Then fold slip and exchange with palmed slip from right hand and return completed slip to owner.

Continue with as many messages as you have time for. Put a great deal of SHOWMANSHIP into the last message or question. Dispose of last palmed slip by placing in pocket.

This method of reading ONE AHEAD will be found very useful. Some members of your audience may have heard of the ONE AHEAD method, but this one completely baffles them for you apparently return the slip to the owner. In the old method the performer merely opened slips and read one ahead but did not return the slips. The important thing here is to start properly and get the message from the first slip and then everything works smoothly.

DISTANT MENTAL COMMUNICATION

This Act is excellent for tests before newspaper men or others with whom you wish to create an impression of unusual ability in mental thought transference. It is not suitable for stage work, as a rule, but is adapted to special occasion work.

EFFECT:

Performer states that his assistant is at a nearby hotel or special room not far away. He says that if there is proper concentration at this end, his assistant can tell what is happening here even at this distance. Several objects freely chosen by spectators are then laid on table. Performer borrows some paper and writes down a list of the articles for checking up later. This is given to a spectator to hold. Another spectator is then requested to write a message to assistant, telling him what he is to do -- that is, to tell what objects were placed on the table. Performer is kept under observation while two spectators go to assistant and deliver their message to him. Assistant sends back a sealed message, which is then opened and shown to be a list of the articles placed on the table.

PARAPHERNALIA:

- 1 -- Three or four sheets of white paper, about 3x5 inches.
- 2 -- White wax, paraffin, or a wax candle.
- 3 -- Lamp black -- can be purchased in powder form at a paint store. A handy way to carry it is in a salt shaker.
- 4 -- A powder puff or some cotton.
- 5 -- A pencil, fairly hard lead.

SECRET AND PATTERN:

To Prepare:

Take one of the pieces of paper and rub one side well with the wax or paraffin, making it a white carbon paper. Place this sheet with two others in your inner coat pocket.

To Perform:

Let us assume that you are performing in someone's office. Tell the spectators that you are about to show them an excellent demonstration of mental thought waves being transferred and picked up like the reception in a radio. You state that your assistant is at a hotel room some distance away. He or she must pick up the waves of what happens here, and to do so, he or she depends entirely on his ability to tune in mentally. Ask for some stationery and, at the same time, take the three sheets of paper from your pocket.

"Any paper will do -- just something to write on. That's it, letter-heads or plain paper."

Place paper on desk, and on it, place your own three sheets. Be sure that waxed side of prepared paper is against upper sheet of borrowed paper.

"Let me request that each of you present help in this experiment, each one at a time. And I will keep track of what you do so as to check up later. First, one of you lay a coin on the desk, any kind and remember the date."

Spectator, let us say, lays a half-dollar on desk. You write on your paper as each object is laid down. The impression of what you write is, of course, left invisibly on the borrowed paper because of the waxed carbon above it.

"First, a half-dollar, date 1918. Now, take a piece of paper and write on it the name of any country, city, or town in the world."

Spectator writes on piece of paper and places it on table.

"That's fine. Portugal. Now, another write the name of any color."

Spectator does this.

"Purple."

Meanwhile you write down each thing as it is done, in list form.

"Anyone got a bunch of keys? That's it. Eight keys on the bunch. Name any number between one and five million. I'll keep track of it. 48, 952. I guess that will be enough for a test. I shall ask you, sir, to hold this list with which we can check up later. You can all pick up the articles now as we have a record of them."

Give sheet with list on it to one of spectators. Casually pick up your other two sheets of paper and put them aside or in pocket.

"Now, I want you to take a sheet of your own paper here and write a letter or note on it in your own words to my assistant, telling her that we have placed a number of things on the desk here and want her to get into mental communication with me so that she can name these things as we have listed them. Use your own language in the message. Then take the letter and seal it in one of your own envelopes. You may deliver it by messenger or take it there yourselves, as you like."

They will probably reach for the top sheet of paper on the desk, but you can aid them by pushing paper over to them so that they will be sure to use it.

After they have written letter and sealed it, give them directions as to where the letter is to be taken.

When letter is delivered to your assistant, she excuses herself for a few moments. In another room, she takes the lamp black and cotton or puff and develops the list on the letter. This method of developing was taught to you in Lesson 29. She then takes pencil and paper and writes out the list of things, making them into sentences rather than just a list. For instance, if you have listed - Eight keys -- as one article, your assistant should write: There were eight keys. She seals her list in an envelope.

When messenger returns with her message, it is checked up with list kept in office and found to coincide.

NOTE:

This method may seem simple, but in its simplicity lies its power. You will find it a wonderful thing to help you establish a reputation. It also works as a mental experiment in your own home. Have one of your family in another room to assist you in accomplishing this wonderful feat of thought transference.

* * * * *

BLINDFOLD CARD READING

This bit of mental work is particularly mystifying because of the use of a blindfold.

(31-17)

EFFECT:

Performer divides a deck of cards into two parts. He gives these halves to two spectators and has them shuffle the cards. One of the spectators is asked to pass through the audience and have about ten cards selected, one at a time. The other spectator is then asked to collect the cards, having each member of audience put his own selection into his half of deck. A third spectator is then asked to shuffle cards again. Magician then passes a blindfold out for examination. He goes back to stage and blindfolds himself. He states that he will pass the cards off one at a time with faces to audience and will pick cards selected. In rapid succession, Magician tells cards selected and names them.

PARAPHERNALIA:

- 1 -- A deck of cards.
- 2 -- A blindfold. This should be made of black velvet or velveteen, doubled and about two inches wide. Sew black braid or tape at each end to make tying on easy.

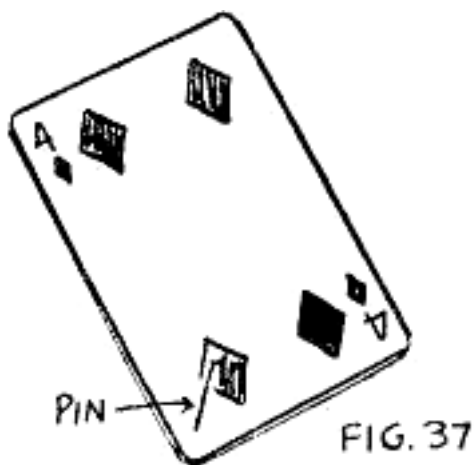
SECRET AND PATTERN:

To Prepare:

Thoroughly shuffle deck of cards and divide it into halves. Take one of the cards and at two opposite corners on the back prick a hole with a pin. Make these holes just within the printed part of card so that they will not be noticeable.

Figure 36.

Now force the pin through from the face of the card also, so that pin prick can be felt on back of card.



Use this card as a guide. Place it on another card of this packet, faces of both up, and using holes for guide, push pin through bottom card at opposite corners.

Figure 37.

Do this with the guide card for rest of this half deck. The pricks are made in opposite corners so that regardless of position of card, pin prick can be felt at lower right corner on back of card.

The other half of deck is left unprepared. Place prepared half, faces of cards up, in left palm. Notice first card of prepared half. Then place unprepared half on top. By remembering first card, you can easily find place to divide the two halves of deck when time comes.

Have blindfold in coat pocket.

To Perform:

Come forward with cards in left hand.

(31-18)

"I have an interesting experiment here in which I use a deck of cards as a fairly rapid method of gaining control of thought waves. I am going to divide the deck into two halves and give one-half to one gentleman here and the other half to another gentleman over here."

Fan cards a little, separate them at key card, and hold half of deck in each hand.

"Will each of you please thoroughly shuffle the cards?"

Give each of two spectators half of deck. Then say to one holding unprepared half:

"That done, I am going to ask you, sir, to go to about ten or so members of the audience and have each select any card he chooses from your half of the deck and hold that card."

Now, to gentleman with prepared half:

"And you, sir, will you please follow the gentleman and have each spectator who selects a card place his card anywhere in your half of the deck?"

After cards have been selected and returned to prepared half of deck, take remainder of unprepared cards and casually drop them in your right coat pocket.

Take prepared half with selected cards in it.

"I believe that you have collected all the selected cards, have you not? Is there any card which has been missed? I believe not. Now, sir, will you please shuffle the cards thoroughly to mix them up well?"

Give cards to spectator to shuffle, then take them again.

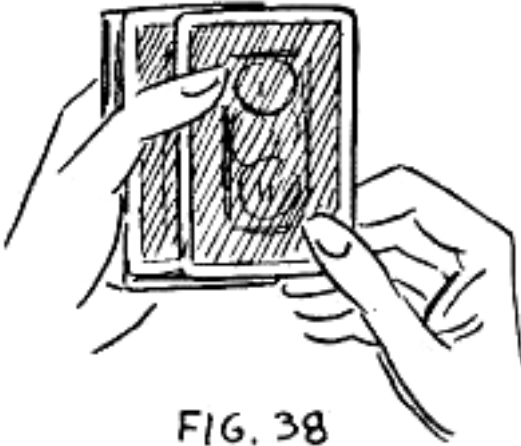
Take blindfold from coat pocket and give to spectator to examine.

"In work of this kind, I find that darkness helps me to gain rapid mental impressions, and for that reason, I have my eyes blindfolded. Will you, sir, please examine this black velvet bandage? You will notice that the bandage is very heavy so as to exclude all light."

Take blindfold again. Go up to stage, place cards on table, and blindfold your eyes. You will find that because of the heaviness of the velvet, the blindfold does not fall in to your cheeks at the bottom and you can easily see under it. Audience believes that you are unable to see, but in reality you can see objects close to you. If you bring a card close to you suddenly, you can get a glimpse of it. Experiment with the blindfold to test its possibilities for yourself.

Pick up cards again and hold in left hand, faces of cards toward audience.

"You notice that I have had a number of cards freely selected and returned to the deck and then thoroughly shuffled in. It is impossible for me or anyone else to tell the location of such cards at the present moment. However, I shall pass the cards one at a time from my left hand to my right, and when you who have chosen cards see your card, concentrate on it and think of it to yourself. I shall endeavor to catch your thoughts and stop at your cards."



Begin passing the cards by reaching over with right hand and taking rear card. Hold it up for a moment. As you take the card, run your right thumb over lower right corner of card to determine whether it has a pin prick in it or not.

Figure 38.

The SMOOTH cards are the selected ones. Pass the cards along, feeling for the pin prick on each one, until you come to a smooth card. Hold it up.

"I get the impression that this is a selected card. Who selected this card? Speak out, please, and say, 'here'."

As you say this, make a gesture with the card to bring it close to your body and thus get a glimpse of the card by looking down under your blindfold. The movement is in toward your body and out again at once so that audience sees it just as a gesture and does not suspect anything.

"The Ten of Diamonds -- is that correct? Thank you."

Drop card to floor or table.

Continue this until you have run through all the cards. Hold each card up for an instant, then drop to floor or table. When you come to a selected card, ask who selected it, and name the card.

"I have discovered each and every card."

Remove blindfold with a quick flourish and make a slight bow.

* * * * *

A MYSTIC DISCOVERY

Another ingenious mental effect with cards.

EFFECT:

Performer has a deck of cards thoroughly shuffled by a spectator and has him select a card and place it in his pocket. Another spectator takes the deck and also selects a card and keeps it. Magician now takes from his pocket a watch chain. The first spectator is asked to hold the free end of it, and the Magician then tells him the name of his card. The second

spectator then holds the watch chain and is also told the name of the card he selected.

PARAPHERNALIA:

1 -- Deck of cards.

2 -- A watch chain.

SECRET AND PATTERN:

To Prepare:

A set of marked cards are used in this experiment. Even though they are shuffled, performer can tell at a glance which cards have been selected by looking at the edge of deck.

First make a KEY CARD. Take one of the extra cards with advertising on, which usually come with a deck -- or use the joker. Mark this card on the back as shown in Figure 39.

Now continue these marks over the left edge of the card so that they can be seen when card is held with only this edge toward you. Use a pencil in marking. You are now ready to mark the deck.

Pick up a card and place it on the Key Card -- backs of both cards up. Say the card is an Ace. Make a little dot on the

(31-21)

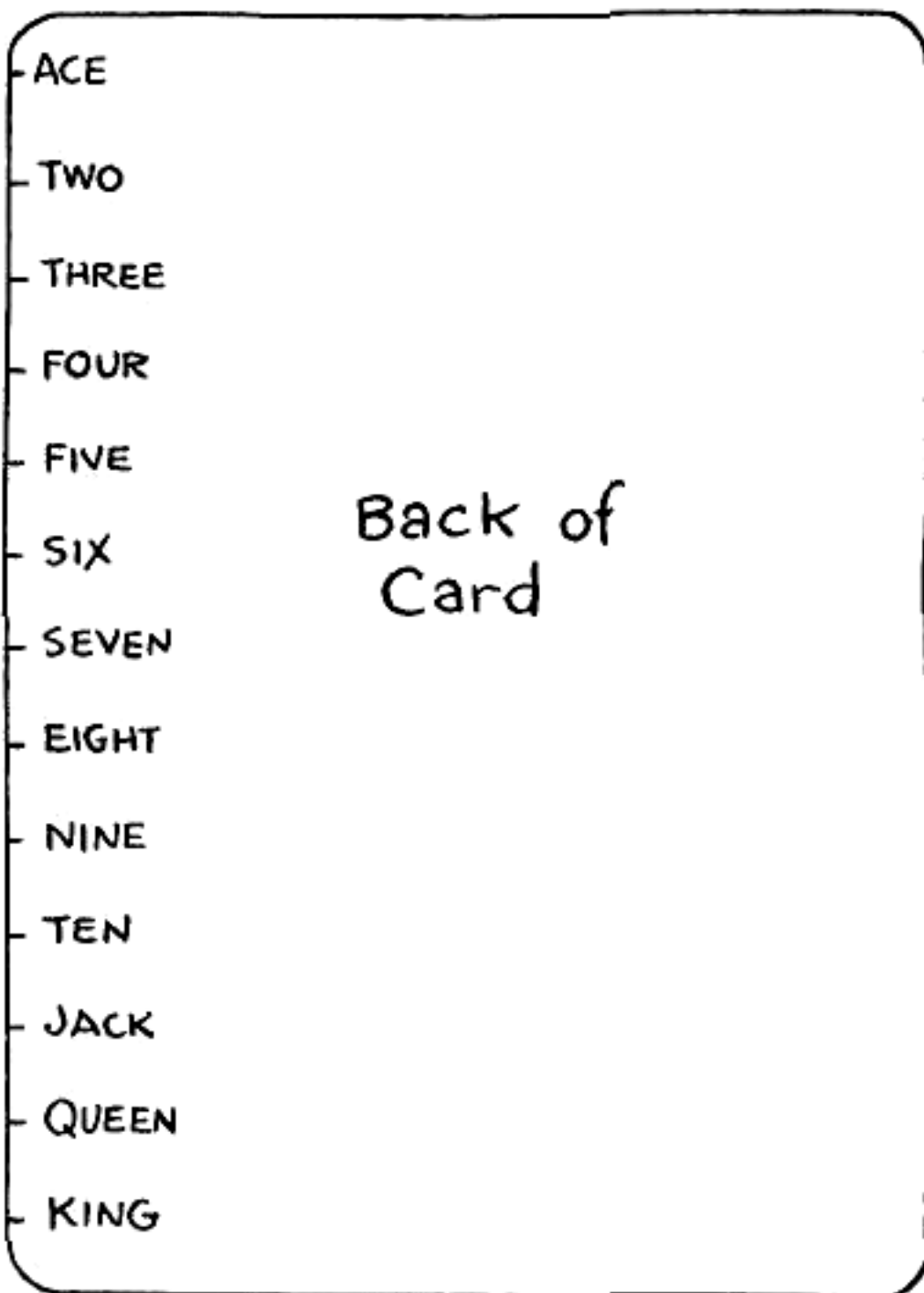


FIG. 39

EDGE only of the Ace just at the point where the marking for Ace is on the Key Card.

To differentiate between suits, use this code:

For a Club - one dot.

For a Heart - two dots, close together.

For a Spade - three dots, close together.

For a Diamond - a short line along the edge of the card.

Thus, if this Ace which you just marked is a Club, the mark is one dot at the point where Aces are marked, according to the Key Card. If it is an Ace of another suit, follow the code and place the mark indicated at the Ace point.

Sometimes the edges of the cards may be marked with black and red ink, but care must be taken that the ink does not spread. If you mark this way, use this code:

For a Club - one black dot.

For a Spade - two black dots.

For a Heart - one red dot.

For a Diamond - two red dots.

Here, I am using the first code in pencil. After you have marked the first card, place it aside and take another. Remember, ONLY ONE EDGE OF CARDS IS MARKED.

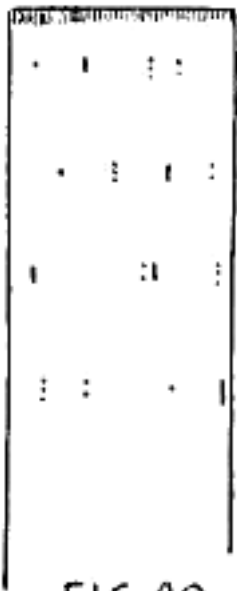
Assume that the second card is the Seven of Hearts. Place it on the key card and mark the edge at the Seven point with two dots. Continue in the same manner to mark all the cards.

Now place the cards together and square up. Hold left edge of deck toward you and this is what you see:

Thirteen rows of markings -- because there are thirteen cards in each suit.

Four kinds of markings in a line in each row because there are four suits of each card.

The rows indicate Ace, Two, Three, Four, Five, Six, Seven, Eight, Nine, Ten, Jack, Queen, King.



The markings indicate Club, Heart, Spade, Diamond.

Figure 40 shows part of the edge of the deck with markings on it.

Remove any card from the deck. Then hold the marked edges toward you again. You can see immediately that one of the thirteen rows has only three markings instead of four. The row in which the marking is missing will tell you what number the card is, and the code tells you which suit it is.

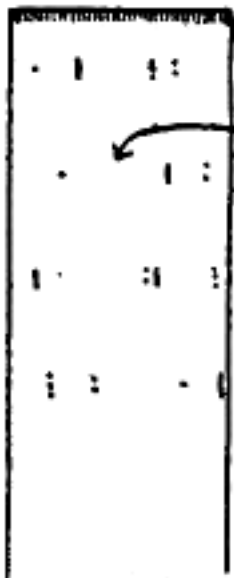


FIG. 41

Assume that you removed the 2 of Spades. The second row has only three markings left – this tells you a 2 has been removed. The missing mark is Three Dots – this tells you that it is a Spade.

Figure 41.

To Perform:

Come forward with deck of cards. Be sure that all marked edges are together. Give cards an overhand shuffle. Hand them to spectator and ask him to give them an overhand shuffle also. The danger of a riffle shuffle is that some of the cards may be turned so that the markings are not all together.

"While the cards are still in your hands, will you please remove one card, remember it, and place it in your coat pocket so that there is no way of my seeing it."

When he has done this, take the cards from him, square them up, glance at the marked edge to see which card has been removed. The three marks in one of the rows instead of four will tell you.

Give cards to another spectator.

"And will you, sir, also remove a card from the deck, remember it, do not let me see it, and place it in your coat pocket?"

This done, take the deck again, square it up, quickly look at edge and determine which card he removed. Place deck aside.

Take watch chain from your pocket.

"As you perhaps know, metal is a good conductor, and I find that a watch chain is an excellent means for carrying vibrations. (To first spectator) Will you please just take one end of this chain in your hand, and I shall hold the other end. Now, concentrate on the card you selected."

Suppose the first selected card is the Seven of Diamonds.

"First the color. I get it -- RED. Now the number -- SEVEN. And the suit -- DIAMONDS. The Seven of Diamonds."

Ask first spectator to take his card from pocket and show to audience, then return it to you.

Now go to second spectator who selected card.

"Will you also please hold one end of this watch chain while I hold the other end. Think of your card."

Suppose his card is the King of Clubs.

"First the color -- I see many colors -- must be a court

card. Think of it -- concentrate, please. It is a King -- the King of Clubs. Is that right? Thank you."

Take card and hold up to audience.

SUGGESTION:

A marked deck like this may be used in many ways in conjuring. I call it the Devil's Deck.

In Lesson 29, I taught you an experiment with "X-Ray Cards," in which you prepared the cards with holes through the index corners to determine selected cards which are placed between them.

Somewhat similar to this is an effect which you may work with a marked deck instead. Mark the edges of about twenty cards, leaving rest of deck unprepared. Give marked cards to someone in audience and you retain unprepared ones. Have spectator select a card from his packet and place it anywhere among your cards, which you hold behind your back. Offer your packet for shuffling. Take the cards back, quickly note marked card by looking at edge of packet, then hold packet to side of your head and name card. Remove this card from your packet and repeat experiment.



TARBELL SYSTEM, INCORPORATED, Chicago.

The paraphernalia described in this lesson can be obtained from the Tarbell System at the following prices, postage prepaid.

Collection Basket	\$10.00
Crystal Balls, size 2"	2.25
Crystal Balls, size 2 1/2"	3.25
Crystal Balls, size 3"	5.25
Crystal Balls, size 3 1/2"	7.25
Crystal Balls, size 4"	9.25
Crystal Balls, size 5"	12.25

LESSON 32

In Lesson 32 I take up the ethics of a magic performance and discuss the relation of one magician to another. Handkerchief magic is given a very thorough explanation, and many very interesting effects are presented.

(31-24)

YOUR RELATION TO OTHER MAGICIANS

A big part of your job as a Magician is not only to make yourself liked by audiences, managers, committees, newspapers, etc., but also by other Magicians. You cannot get very far in the Magic World if your Brother Magicians dislike you. Now, what causes a Magician to be disliked? Just those things which cause any professional or business man to be disliked: Too much egoism, knocking of others, never cooperating with others.

I have always preached to you the necessity for having CONFIDENCE in yourself. BUT remember that OVER-CONFIDENCE leads to disaster. Base your confidence on a real, fundamental knowledge of Magic and not just on a superficial air of "knowing it all." When a man has the real Professional spirit, he never tries "to show off." Everyone knows that he has ability by his work, and there is no need for him to take the "greater than thou" attitude. The super-egoist is constantly overstepping his bounds in his great desire to push himself into the limelight. He never thinks of others, only of himself. The inevitable result is that he gets himself thoroughly disliked by brother magicians.

Howard Thurston says, "There is great danger when a man believes his own publicity." REMEMBER THAT.

The really great man is ever learning. He is not so much engrossed in himself that he is blinded to the knowledge of others. It is only the small man who makes a big noise about how much he knows. He is the man who hurts himself and the whole profession of magic.

Knocking others is the mark of the insignificant man every time. This person thinks that by belittling others, he makes himself stand out greater. To be known as a knocker makes him stand out--yes--but in what an unfavorable light!

Be a booster! It means that you are boosting the other fellow and the whole profession of magic--and in that way, you are boosting yourself. You make yourself liked, and when you have done that, you have gone a long way up the road to success.

No man is sufficient unto himself. Everyone depends on other people for his success in life. In magic, there are times when other magicians need you--and there are times when you need them. Cooperation is absolutely necessary in this profession. You must lend your fellow magician a helping hand when he needs it, and you will find him ready and eager to help you.

Encouragement and appreciation for the work of a fellow member of the magic profession will reflect back on you and will bring you ample reward. If you know human nature at all, you know that everyone craves appreciation and everyone

likes the person who gives it to him. So, be ever ready with a kind, cheerful word for a brother magician.

Big things are accomplished only by the cooperation of everyone for the good of the whole. By that I mean, every magician must work hand-in-hand with every other magician toward building a greater and greater profession of magic. Such cooperation means fresh ideas, new material, and a bigger outlook for the whole profession--and thus for you.

The big idea of magic must first be sold to the public. All magicians must work together to accomplish this. When this is done, then comes the demand for the individual magician--for you.

So remember--

It is very important to make other magicians like you, and this is how you do it:

SUBDUE YOUR EGO,

BE A BOOSTER,

LEND A HELPING HAND TO BROTHER MAGICIANS.

* * * *

ETHICS AT A MAGIC PERFORMANCE

When you attend another magician's show, go with the idea of helping that magician in every way possible. The better he is, the less he will need help; and the poorer he is, the more he will need assistance. When a real magician comes to town, his brother magicians always make it known to him that they are ready for service. If he desires them to come up from the audience while he is performing, they are ready to do so. If he wants encouragement and appreciation from the audience, they are ready to lead in applause.

However, remember that after you have shown yourself ready to cooperate, it is your place to sit back and wait until your help is requested. You must not thrust your help on the performer for he may not require it.

A very serious offense is to try to make yourself stand out in the audience while another magician is performing.

The audience came to be entertained by the performer, and they resent disturbance by a spectator. I have sometimes heard a spectator call out during a magic show, "Oh, I know how that's done. I can do it myself." That person thinks he has created a big impression with the audience, but he has only succeeded in making himself an unpleasant disturbing element. The audience is not interested in whether he knows how to do the trick or not. They are interested only in the performer and are antagonistic to anyone who tries to distract their attention.

The performer, too, naturally resents this disturbance. The undivided attention of the audience is necessary for him to gain his greatest success. Anything which draws the attention of the spectators even momentarily away from him hinders his work. Of course, the performer has nothing to fear. He has the upper hand. If he is a good performer, his personality is so strong when he is in action that another personality seems weak by contrast. His regard for the disturbing spectator is nil, and with little effort, he makes this "wiseacre" appear a fool in the eyes of the audience. If the spectator persists in interrupting, he is due for a hard fall in the hands of the experienced showman. It is no trick for the experienced performer to make a laughing stock out of the "wise one."

I have seen amateur magicians go onto a professional stage to assist a performer, and then without warning, start doing tricks themselves. Their object is to get into the limelight. And they do—but with what disastrous results to them! The clever showman exposes their lack of training in no time, and the would-be "smart" amateur is looked upon with contempt by the audience. So you see the grave danger there is to the person who does not keep his place in the magic profession.

There is one other thing I want to impress upon you, and that is—A MAGICIAN IS A BUSY MAN. Do not impose on him by taking up his time and by being in the way. It is perfectly all right for you to call on him. Give him a friendly greeting and an offer of your services, and then leave.

Do not stay around his stage while he is setting up his show unless he asks you to. Every magician has his own secrets which he may not want you to know. He has perhaps spent years in working out some of his effects, and he does not wish to impart them to you. The fact that you are a magician does not give you the right to break into the privacy of another's domain.

Being a TARBELL STUDENT entitles you to many privileges in the magic profession. You profit by my wide acquaintanceship and reputation. For you to say, "I am a Tarbell Student," is an excellent introduction for yourself. Use it—but only in the right way. You have an obligation to yourself—to your fellow students—and to me, to uphold my reputation.

I have every confidence in you. That's why I am initiating you into the innermost mysteries of magic, and that's why I am giving you all the sidelights to insure your success in the profession. Your success means everything to me, and I want to see you do big things in magic.

SILK HANDKERCHIEF MAGIC

Silk Handkerchief Magic is very popular because of the flash which it gives to a performance. The various colored silks make it possible to give some very pretty effects.

Silks are light in weight and pack easily and have much to recommend them in a magician's program. You will do well to become thoroughly skilled in this branch of magic.

* * * *

MYSTIC KNOTS

So effective are magical knots that tie and untie themselves that the great Houdini used to feature knot effects in his show. Houdini used large, brightly colored silks, and his work with them was certainly beautiful. The larger the silk you can use, the greater the flash of the effect. Twenty-seven inch squares of silk are fine for knot work, especially on the stage. However, this work can be done at a moment's notice anywhere with ordinary pocket handkerchiefs. For general silk work, use Chinese or Japanese silk. Launder it well before using. It is springy and folds up small. It also has the advantage of being made in many brilliant colors.

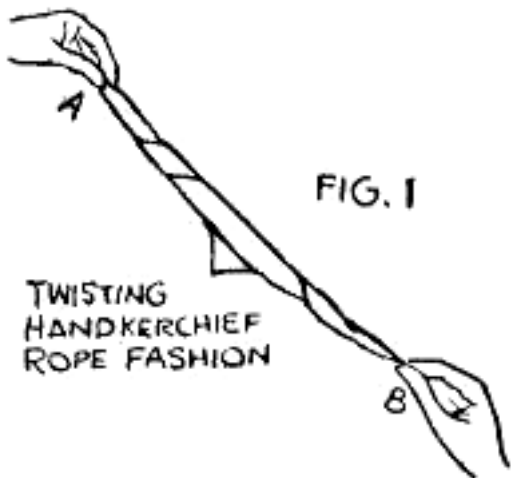
THE PULL-AWAY SINGLE KNOT

EFFECT:

Performer ties a single knot in a handkerchief. Suddenly the knot disappears.

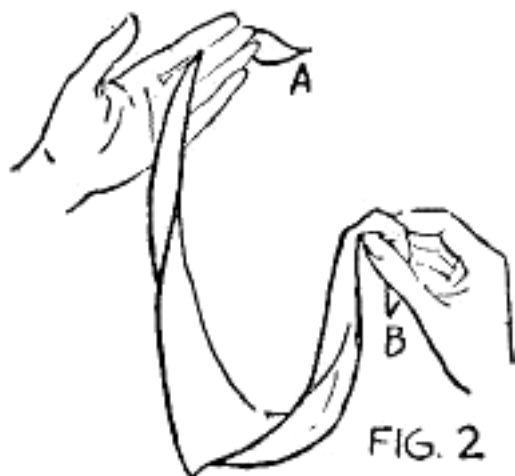
TO PERFORM:

Hold handkerchief by opposite corners and twist it rope fashion. End A is in left hand, and end B is in right hand. Figure 1 is view toward yourself.



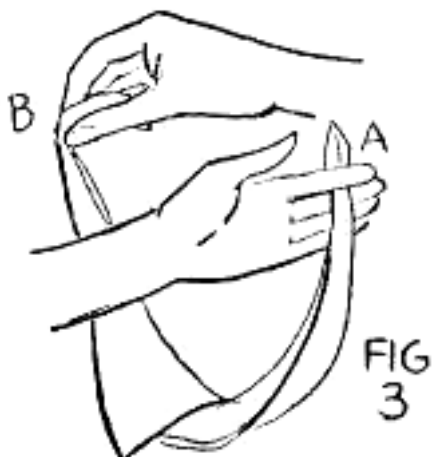
Place end A between first and second fingers of left hand. B is held between thumb and first two fingers of right hand.

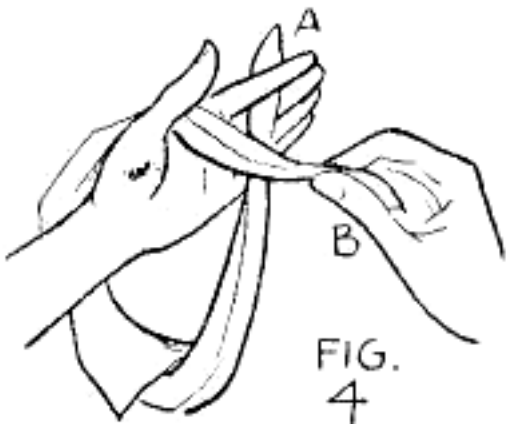
Figure 2.



Bring right hand with B in front of left wrist.

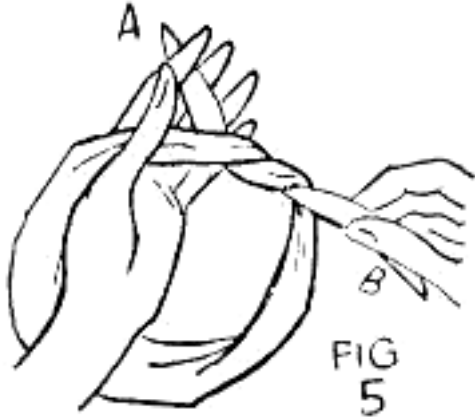
Figure 3.





Bring B over base of left index finger. Or, if silk is very large, bring it back of thumb and over base of it.

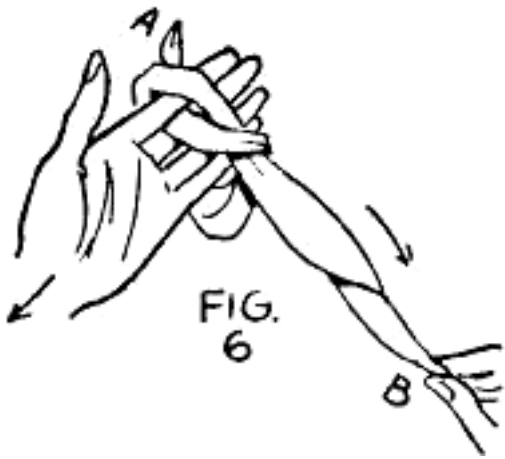
Figure 4.



Tie B around A so as to form a single knot. Show knot so that all can see it. Turn palm of left hand toward audience as far as possible so that they can see nothing is concealed.

Figure 5.

(32-4)



Pull B to the right and A to the left and toward you. It appears that you are tightening knot.

Figure 6.

Then the silk slides off left fingers and unties itself. Be sure to keep end A grasped between fingers to accomplish this.

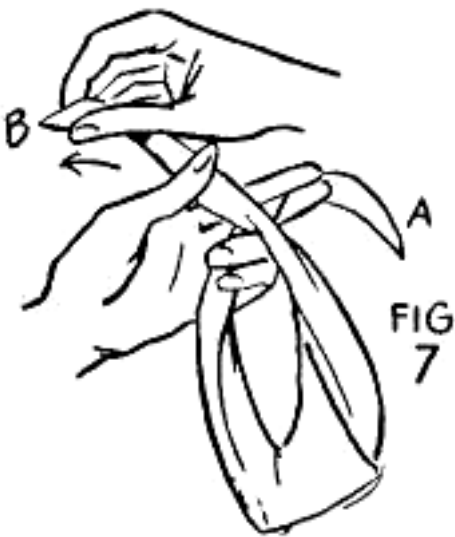
THE DISSOLVING SINGLE KNOT

EFFECT:

Performer ties a single knot in handkerchief and places handkerchief on a chair. Then he lifts handkerchief again, and knot has disappeared.

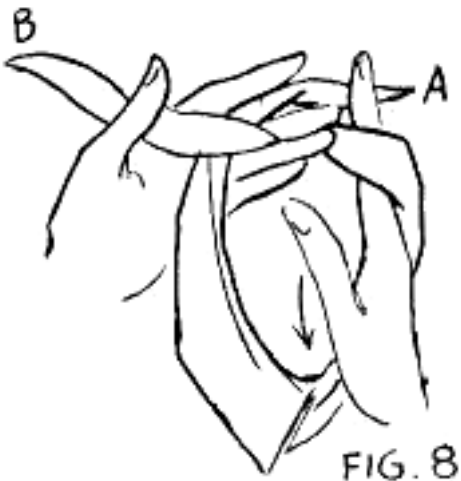
TO PERFORM:

Hold end A of handkerchief between first and second fingers of left hand and end B in right hand as in Figure 2.



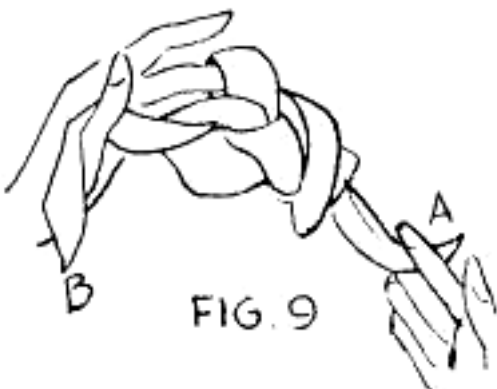
Curl third and fourth fingers of left hand down to grasp handkerchief securely. Bring end B in right hand over these fingers and in front of first and second fingers. Grip B between thumb and base of first finger, releasing right hand.

Figure 7.



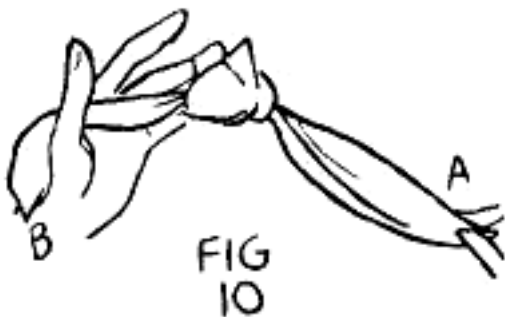
With right hand reach inside loop of handkerchief and grasp A. End B of handkerchief is held tight between second and third fingers of left hand, as well as thumb and first finger.

Figure 8.



Bring A down and through loop of handkerchief.

Figure 9.

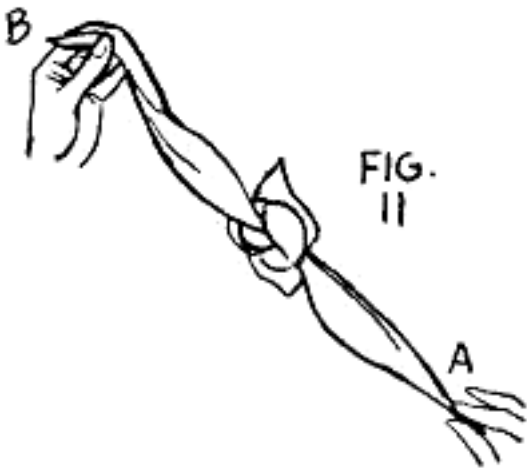


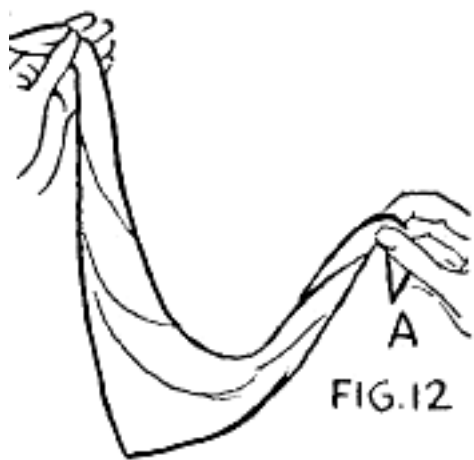
As you continue to pull end A to the right, curve second and third fingers and draw them backward a little, pulling part of the handkerchief with them. This causes a looping of the handkerchief which looks like a knot.

Figure 10.

Release second and third fingers from knot and hold handkerchief as shown in Figure 11.

(32-5)





Lay handkerchief on seat of chair. Then pick up end B with a slight upward jerk and the knot fades away. If desired, instead of placing the silk on a chair, merely pull both ends of it and it unties as you hold it between your hands.

Figure 12.

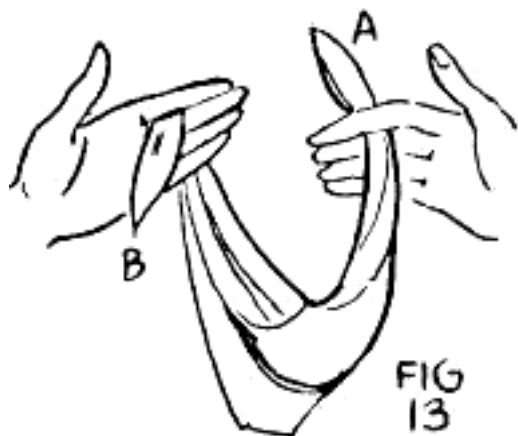
Experience will teach you how tight or how loose to make your knots. They must be tight enough to hold and yet loose enough to untie easily.

This is a pretty effect when worked with two or three large brightly colored silks. Tie each and place it on the chair. Then jerk them upward one at a time, and the knots dissolve.

THE SPEEDY SINGLE KNOT

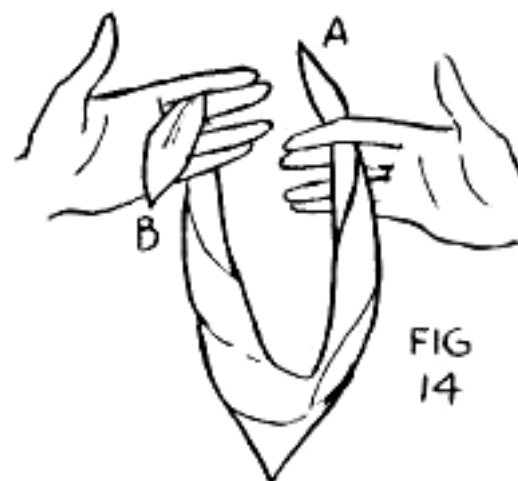
EFFECT:

Performer holds a handkerchief by opposite corners in his two hands. He brings his hands together and pulls them apart instantly, and suddenly a knot has appeared in the handkerchief.



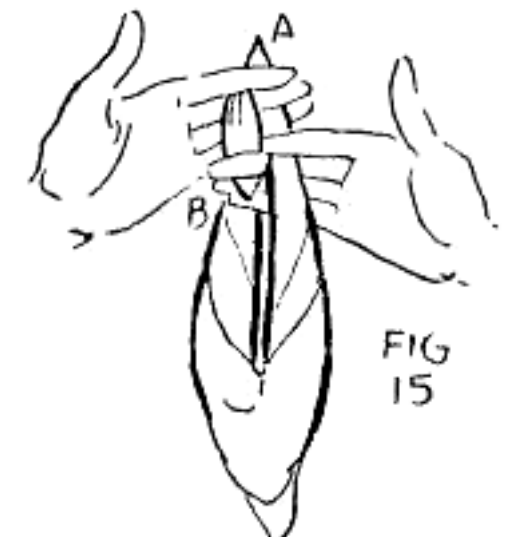
TO PERFORM:

Hold silk as in Figure 13. End B comes between first and second fingers of left hand from front (toward audience) to back (toward you). End A comes between first and second fingers of right hand from back to front.



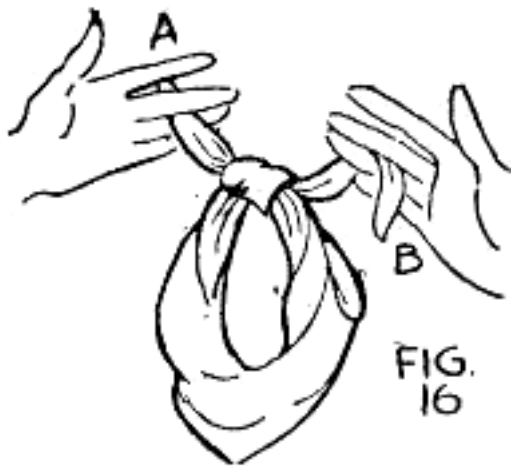
Bring hands together with right hand inside of left hand.

Figure 14.



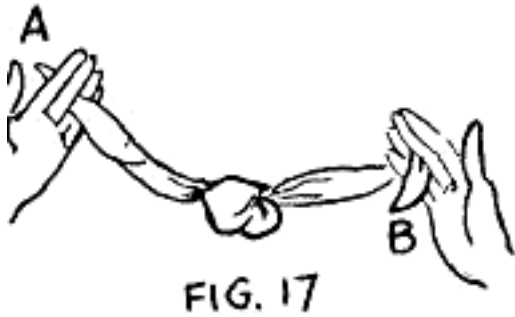
Grasp A between second and third fingers of left hand and B between the same fingers of right hand.

Figure 15.



Releasing ends from first and second fingers of both hands, draw B to right and A to left between second and third fingers of each hand.

Figure 16.



Continue drawing ends apart until a single knot is tied in silk.

Figure 17.

NOTE:

This makes a good tie when used in contrast with the ordinary manner of tying a single knot. First tie a knot as it is usually done. Then explain that a magical knot is much speedier and better and proceed to tie the speedy magical knot. Rolling the silk rope fashion facilitates working.

Practice this until you can do it so quickly that it appears that you merely put your hands together and the silk knotted itself.

THE FADE-AWAY DOUBLE KNOT

This is an effective knot for easy release. It is important in Sympathetic Silks which follows later in this lesson.

EFFECT:

Performer ties two handkerchiefs together in a double knot. Silks are then laid on the seat of a chair. Magician picks them up suddenly, and they are found to be untied.

TO PERFORM:

Take two silks. Place corners A and B together. A in left hand is toward you and B in right hand is toward audience. With thumb and first finger of right hand, grasp A, still retaining hold on B with lower fingers. Perform the same move with left hand to grasp B.

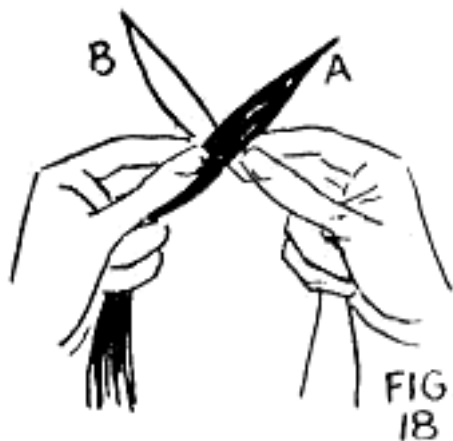
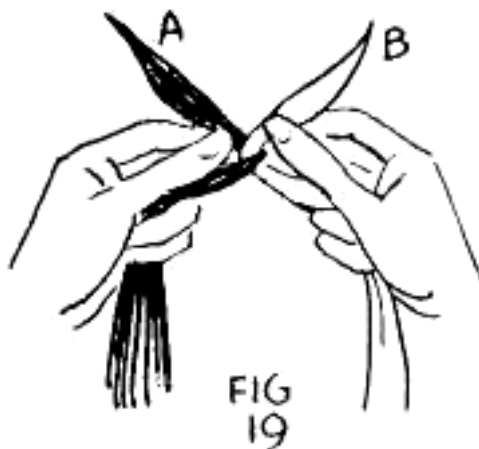
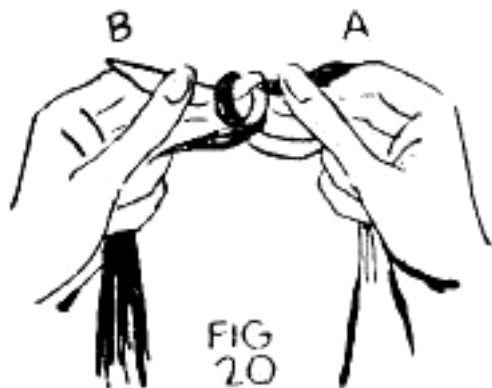


Figure 18.



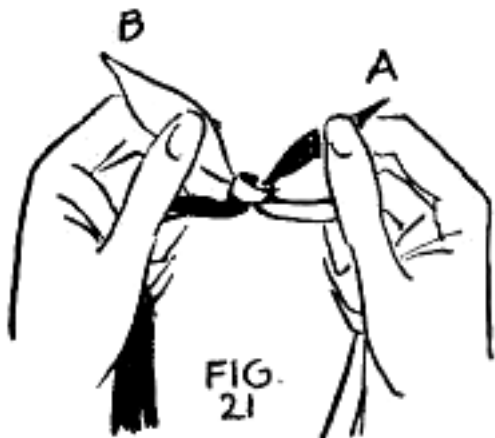
Bring ends of silks up about on a level with chest, then down again suddenly. In your downward movement, twist ends B and A around each other quickly. The effect to the audience is that you have tied a single knot.

Figure 19.



Now tie a regular single knot with the ends.

Figure 20.



Pull knot tight with thumbs and first fingers of hands, also assisting with lower fingers of each hand which still grasp silks tightly beneath knot.

Figure 21.



Grasp lower corner of handkerchief in right hand and hold the two silks, apparently tied together in a double knot, as in Figure 22.

Place the tied silks on the seat of a chair. Pick them up a moment later with a jerk, and the knot fades away, leaving the two silks separate.

(32-7)

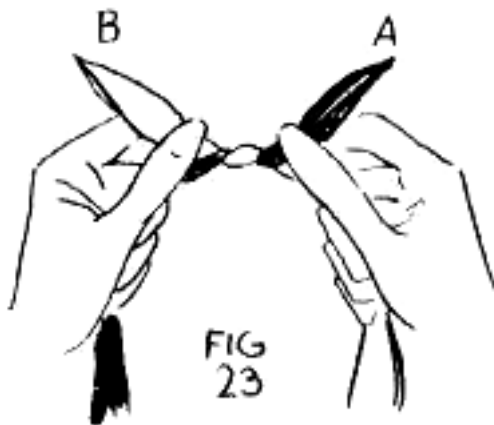
FIG.
22

QUICK RELEASE DOUBLE KNOT

This is a real double knot, but you easily make it into a slip knot which can be released quickly.

EFFECT:

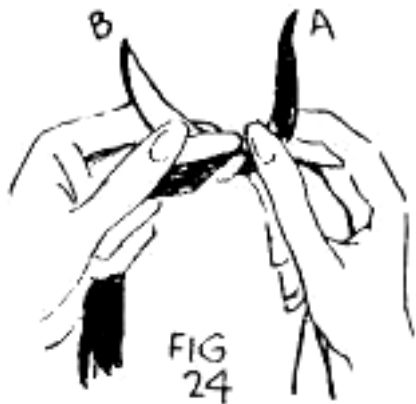
Performer ties the ends of two handkerchiefs together in a double knot. At his will, the knot unties quickly.



TO PERFORM:

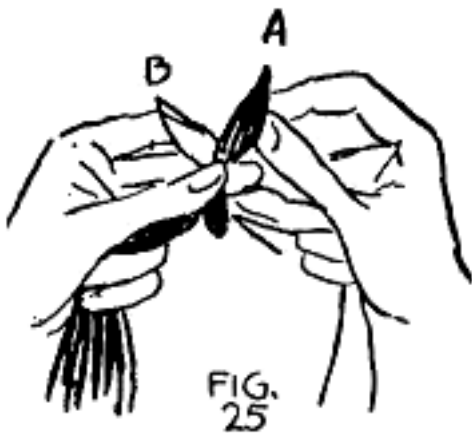
Tie A and B in a single knot, looping A over and under B.

Figure 23.



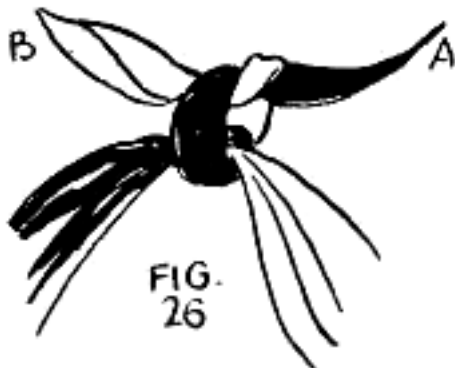
Hold B securely with thumb and forefinger of left hand and lower part of silk with other fingers. Hold A in same manner with right fingers. Slip second finger of left hand under A where it first loops over B and press finger against B.

Figure 24.

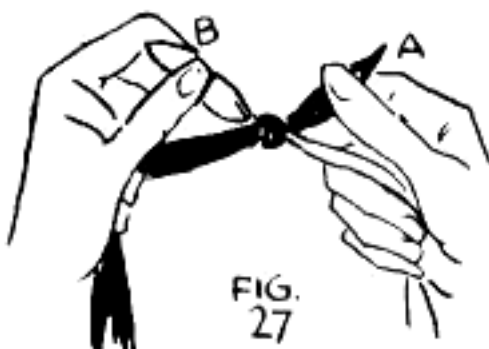


Bring end A in right hand down a little toward you and up again over second finger of left hand.

Figure 25.

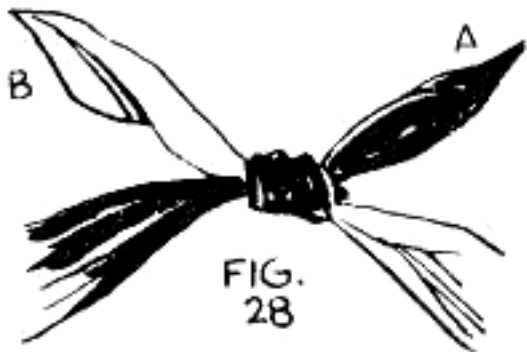


Now bring end A back of and around end B. Loop it through B to make a single knot and bring end A out to the right again. Study Figure 26 carefully so that you get the proper looping of the two ends.



Hold silks as in Figure 27. Do not pull on A. Pull B above and below the knot to tighten it.

Figure 27.



The object of pulling on B is to get it into a straight line, thereby making a slip knot of A. B now merely runs through A.

Figure 28.

By pulling silks apart below the knot, it quickly disappears. An effective way of dissolving the knot is to hold the silks as in Figure 22, and then roll them around the right hand, releasing the knot as you do so under cover of left hand.

Continue wrapping handkerchiefs around hand, and then unroll them suddenly to show that knots have dissolved.

(32-8)

By tying silks farther from ends, you can tie several knots on top of the double knot, following the principle used in the second tying of the double knot. Slip knot each as you tie it, and the knots will readily dissolve when you pull the silks apart.

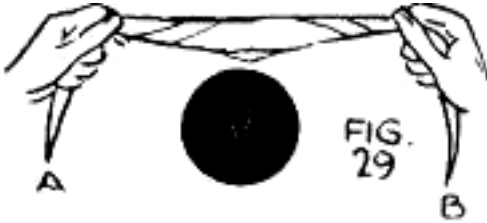
* * * *

LEG TIE AND RELEASE WITH HANDKERCHIEF

This effect requires the use of a large silk. It always goes over with good results.

EFFECT:

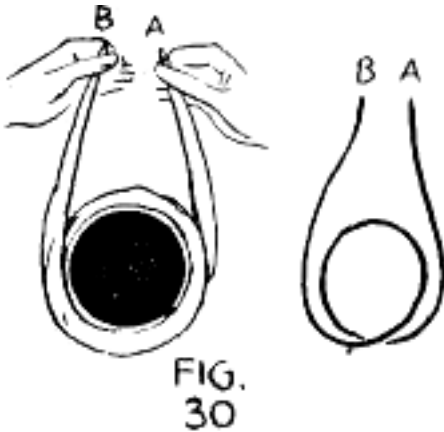
Performer twists handkerchief twice around his leg, above the knee. While securely holding both ends in one hand, he jerks handkerchief and it suddenly frees itself from his leg.



TO PERFORM:

Hold handkerchief in front of left leg above the knee (represented by black circle). Silk is rolled into a rope.

Figure 29.



Bring handkerchief against leg and twist it around leg. Bring ends forward toward audience again. Figure 30 shows actual twisting of handkerchief around leg and a diagram of the looping of the handkerchief.

Pull ends of silk to show that it is secure around leg. Take silk from around leg and hold again in position shown in Figure 29.

Now you pretend to twist the silk around leg in same manner, but in reality you employ a magical principle in twisting it around.

Bring hands with ends A and B to rear of left leg. Place right thumb against B and right forefinger in front of A.

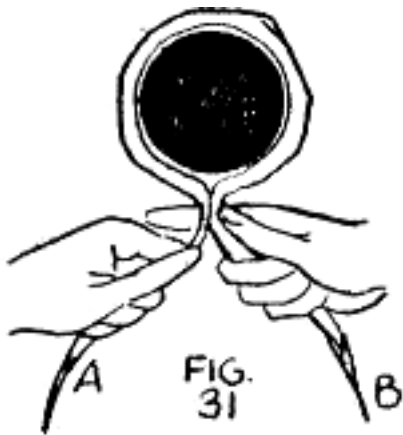
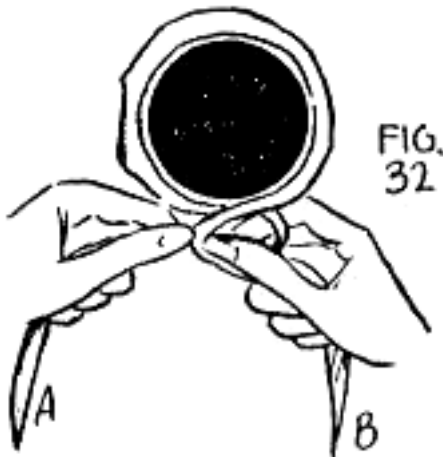
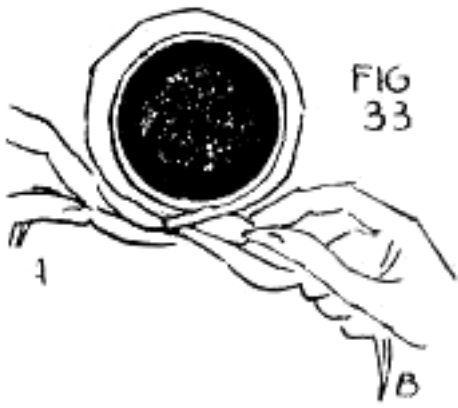


Figure 31.



Hook right forefinger around A, pulling it to right under B. Right thumb pushes B to the left. Grasp B with left thumb and forefinger.

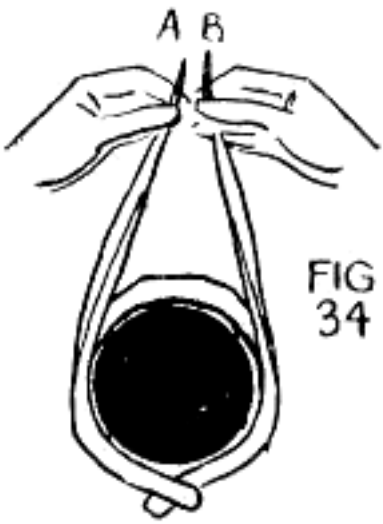
Figure 32.



With left thumb and forefinger, push B around under A and pull it through a little way to right with right thumb and forefinger. To do this, of course, you release B from left hand and release A from right.

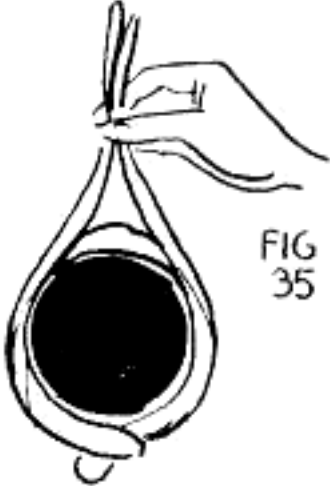
Figure 33.

(32-9)



Bring ends A and B out in front of leg again.

Figure 34.



Take both ends of silk in right hand. To audience it appears that you twisted the silk completely around leg as you did before.

Figure 35.

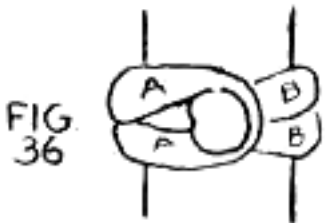


Figure 36 is a diagram of the looping of the silk at the back of the leg away from the audience.

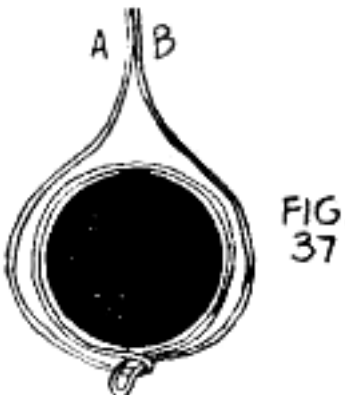


Figure 37 shows how this same principle may be applied to the use of a rope around the leg instead of a silk.



Figure 38 shows performer as he looks to audience with silk apparently twisted completely around his leg.



FIG. 39. Figure 39.

Jerk silk with right hand and it releases itself from leg. It remains suspended in a loop from right hand.

After silk is released, look at audience and say, "Now, you know that isn't so."

This release may be performed with an ordinary pocket handkerchief around a spectator's wrist. Be sure to make fake loops in the handkerchief under the wrist so that they are not visible to spectator or any other members of audience.

* * * *

THE MAGICAL BOW KNOT

A neat effect produced by G. W. Hunter, a clever magician of England.

(32-10)

EFFECT:

Performer holds a handkerchief in his hands. He brings his hands together and then apart again, and a bow knot is found tied in the handkerchief. To make the knot doubly strong, he inserts the ends of the handkerchief through each of the bows. At command, the handkerchief unties itself.

TO PERFORM:

A rather long and narrow piece of silk lends itself best to this experiment. A fairly large silk handkerchief, twisted rope fashion, or even a piece of clothesline may also be used, however.

Hold handkerchief in both hands as in Figure 40.



FIG 40

Turn palm of right hand toward body and bring hands together.



Figure 41.

Extend first and second fingers of right hand in back of left hand.

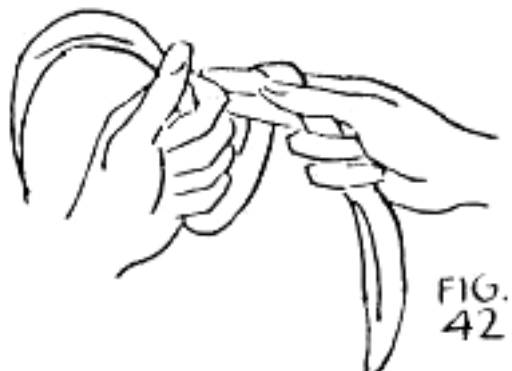


Figure 42.

Grasp upper end of silk between first and second fingers of right hand. Extend same fingers of left hand and grasp lower end of silk between them.

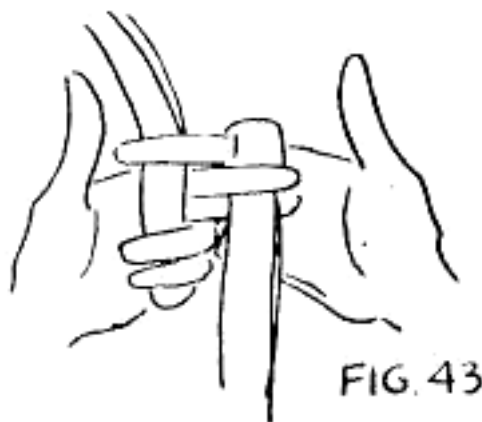


Figure 43.

Pull hands apart and the silk is looped into a bow knot. This must be done quickly so that it appears that you merely put your hands together and the bow knot appeared.

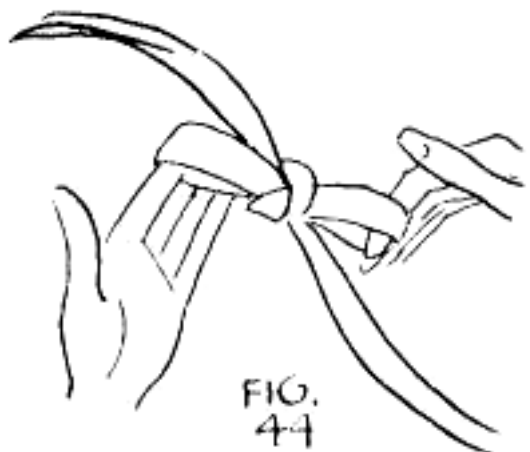
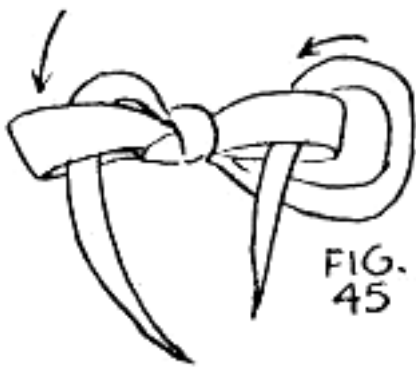


Figure 44.



Insert an end into each bow. Be careful how you do this. Bring the ends up and back of the bows, through them and toward you.

Figure 45.



Hold ends as in Figure 46. Bow is in center of handkerchief.

Then pull ends apart and handkerchief unties itself.

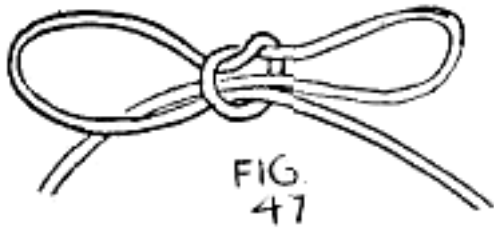


FIG. 47

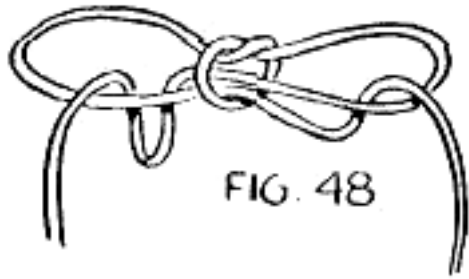


FIG. 48

Figures 47 and 48 are diagrams of the bow knot effect in the first and second stages. Clothesline was used. Study it carefully and practice it so that you have no difficulty in performing it quickly. Once you learn just which way to put the ends through the bows, you will never have any trouble in performing the effect.

CHAIR TIE AND RELEASE WITH BOW KNOT

EFFECT:

Performer ties rope around top of chair with bow knot on top. At command, rope frees itself from chair. This may also be performed with a handkerchief.



FIG. 49

TO PERFORM:

Place rope under top of chair and bring it around ready to tie a bow knot.

Figures 49 and 50.

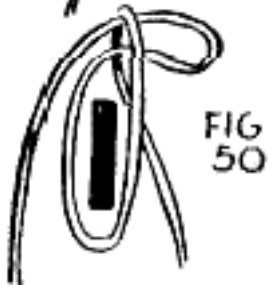


FIG. 50

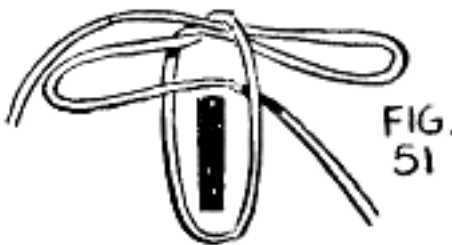


FIG. 51

Complete the tying of the bow knot at top of chair and draw it tight. Bring right end of rope under top of chair to left side.

Figures 51 and 52.



FIG. 52

Pull the two ends together, and the rope unties and falls away from chair.

* * * *

REPEAT HANDKERCHIEF VANISH

A handkerchief vanish which permits of good comedy. This is an adaptation of an effect originally performed by Oswald Williams, a well known English magician.

EFFECT:

Performer removes a silk handkerchief from his right vest pocket. With his right hand, he tucks it into the closed palm of his left hand. Magician opens his left hand, and the handkerchief has vanished. He again takes a handkerchief from his vest pocket and vanishes it in his left palm also. He repeats this a number of times with suitable patter, and finally changes the handkerchief into an egg or a lemon.

PARAPHERNALIA:

1--A handkerchief pull. This was sent to you FREE with your early lessons.

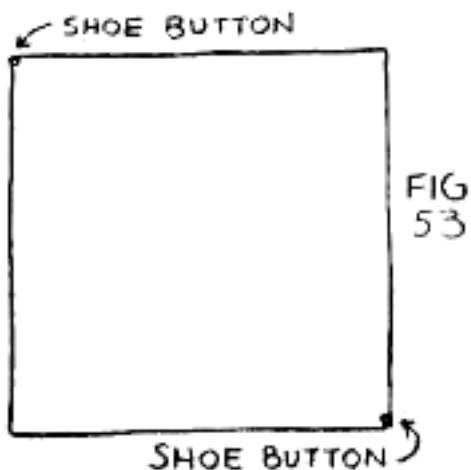
2--A piece of good black elastic. This should be round and cloth-covered.

3--A hollow celluloid egg with a hole in one side for vanishing handkerchief. We can supply you with this at a reasonable price.

4--Two silk handkerchiefs, exactly alike, about 13 inches square. Use handkerchiefs which we furnished you earlier in the Course, or make some new ones of China silk.

5--Three small shoe buttons.

SECRET AND PATTERN:



To Prepare:

Sew a shoe button on one corner of the handkerchief and another button at the diagonally opposite corner. One button acts as a "feeler" in manipulation of the silk, and the other acts as a "throw out" for easy grasping of handkerchief when it is in the "pull."

Figure 53.

The "pull" is the regular handkerchief "pull," but the elastic is arranged a little differently. It is drawn up through the hole in bottom of "pull" out through the opening. Allow just about one-half inch of elastic to extend above opening. Make a knot in elastic on each side of bottom hole of "pull" to keep it in place. Then make a knot in end at opening of "pull" and sew elastic securely to one corner of handkerchief with shoe button. Attach safety pin to other end of elastic.

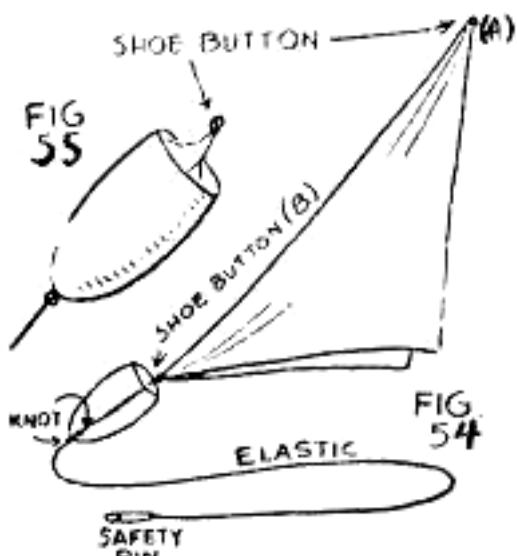


Figure 54.

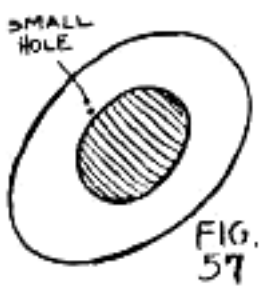
Tuck handkerchief into pull. End of handkerchief with shoe button A goes in last.

Figure 55.



Place "pull" in vest pocket. Make a small hole in farther corner of pocket. Run elastic through this hole, around your waist, and up on your back where it is attached. Arrangement is the same as in the ordinary vanish, taught to you in Lesson 28, except that "pull" is placed in vest pocket. In emergency, it may be worked from the side in the ordinary manner.

Figure 56.



Take the hollow celluloid egg. To one side of the opening, make a small hole. Sew one corner of the second handkerchief to this hole. To opposite corner of handkerchief sew a shoe button.

Figures 57 and 58.

(32-13)





FIG. 59

Make a small pocket in left side of your coat. You will find this pocket useful for many things. Tuck handkerchief into egg, arranging it so that shoe button can easily be reached. Then place egg in this special pocket in coat.

Figure 59.

To Perform:

Come forward with "pull" and egg properly arranged.

"The other day I was standing out in front of a small conjuring or magic shop, looking in the window. One little show card, in particular, caught my eye. On it was a description of a trick with a handkerchief. It said that the performer reaches into his vest pocket and removes a handkerchief."



FIG 60

With right hand, reach into left vest pocket. Grasp shoe button extending from Pull and draw out the silk. Place left hand at left edge of coat and draw handkerchief through left hand until "pull" comes into left palm. Stretch the elastic as you draw handkerchief out until shoe button B is at tips of left thumb and fingers. Keep back of left hand toward audience all the time.

Figure 60.



FIG 61

To the audience it appears that you merely took a silk handkerchief from your pocket and are holding it up by the corners as shown in Figure 61.

"He then holds the handkerchief by the corners, one in the left hand and one in the right. Now, taking the first finger of his right hand. ..."

Release hold on silk with right hand and allow it to hang suspended from left hand.

"He pushes the silk handkerchief into the closed left hand."



FIG. 62

With right forefinger tuck silk into the "pull", leaving shoe button A on top. Open bottom part of left hand enough to release "pull" and let it fly back to vest pocket. If you watch your ANGLES OF VISIBILITY here, this move will not be detected. Continue pushing first finger of right hand into left fist for a moment.

Figure 62.

"This causes the silk to disappear."

Open left hand to show silk has vanished. Also show right hand.

"Personally, I didn't think it could be done, so I walked into the store and said to the man behind the counter, 'Pardon me, sir, but have you a trick in which you take a silk handkerchief out of your pocket.....'"

Reach for silk again, taking shoe button and pulling silk through left hand again until "pull" is in left palm, as before.

" 'And then hold it by two corners, one in the left hand and the other in the right, and then take the first finger of the right hand.....' "

Drop corner from right hand and push silk into closed left hand with right forefinger, as before.

" 'And push the silk into the closed left hand.....' "

Push silk into "pull" and release, as before.

" 'Only to find that the silk handkerchief has disappeared?' 'Oh,' said the man standing behind the counter, 'you mean that trick in which the performer takes a silk handkerchief from his pocket.....' "

Again remove silk from vest pocket and perform your routine.

" 'And holds it by two corners, one in the left hand and one in the right, and then with the first finger of the right hand, pushes the silk into the closed fingers of the left hand.....' "

Push silk into pull and vanish again.

" 'Only to find that the silk handkerchief has vanished. Yes, yes, I will show it to you.' And he did. Now, ladies and gentlemen, that I have learned the trick, I will show it to you. First the performer removes his silk handkerchief from his pocket."

This time reach down and tuck "pull" into vest pocket to get it out of sight. Then reach over to special pocket in coat. Grasp shoe button on handkerchief in egg. Pull it out and get egg into left palm. Hold silk as before between left and right hands.

"He holds it by two corners, one in the left hand and the other in the right hand. Then with the first finger of the right hand, he tucks the silk handkerchief into the closed fingers of his left hand."

Tuck handkerchief into the egg in left palm.

"And then you have an EGG."

Show egg to audience, keeping opening out of sight.

Figure 63.

* * * *

(32-15)



AN EGGS-TRAORDINARY EGGS-PLANATION

A good "sucker" effect, in which a trick is apparently explained but finishes with a surprise.

EFFECT:

Performer shows a handkerchief and tells audience he will cause it to disappear in a mysterious manner. He rolls it up in his hands and pretends to put it into his left hand. He then places his right hand in his right trouser's pocket. Audience believes that he placed the handkerchief in his right trouser's pocket. Magician, however, opens his left hand and shows that handkerchief is really in his hand. He rolls up handkerchief again, and this time it changes into an egg. Saying that he will explain the trick so that the spectators can do it, too, Magician shows that the egg is just a hollow celluloid egg with a hole in it into which he tucked the handkerchief. He pulls out the handkerchief and repeats the experiment, changing the handkerchief to an egg again. Performer then explains that in case anyone is suspicious of the egg, all that has to be done is to break it. He does this and allows the contents of the egg to fall into a glass, thus showing the egg to be a real one.

PARAPHERNALIA:

1 -- A hollow celluloid egg with opening large enough to admit a silk handkerchief.

Same kind of egg as used in Repeat Handkerchief Vanish, explained in this lesson.

2 -- A silk handkerchief, about 13 inches square.

3 -- A good-size door key, to act as a Magic Key.

4 -- A real egg.

SECRET AND PATTERN:

To Prepare:

Place hollow egg in right trouser's pocket

Place key in same pocket.

Place real egg in left coat pocket.

To Perform:

Come forward with handkerchief.

"I hold in my hand what is known as a magic square of silk. To all ordinary appearances, it is but a silk handkerchief, but from an extraordinary angle, it is more than that for it has the power of separating itself into minute atoms and then reassembling itself under the proper influence. Because of its peculiar properties, it will vanish before your very eyes, and no one will be able to see where it goes."



Roll silk up in hands into a small ball. Figure 64 shows performer rolling silk, as he appears to audience.

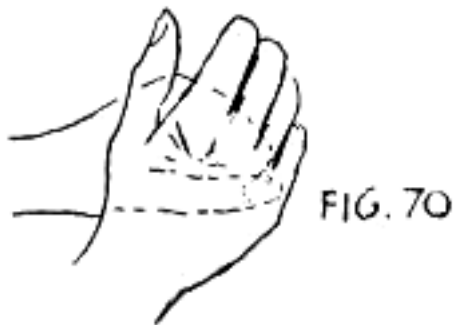


It is important for you to learn how to roll a silk quickly into a compact ball. Study Figures 65 to 69 carefully and practice the moves thoroughly until you have them mastered.

Start with a corner of the silk, allowing the rest to hang over back of left hand. Start moving the right hand in a rotary motion clockwise. Help feed the silk in with left thumb. Once you get the ball started, rolling the rest is easy.

Have skin of your hands slightly moist or sticky, and you will find the rolling easier to accomplish than with a dry skin.

"Watch the silk closely as I roll it into my left hand."



When silk is rolled into a small ball, close left hand around it and turn back of hand to audience. At same time, close right hand and bring it away from left as if you had something in it. You are trying to lead audience to believe that you have handkerchief in right hand.

Figures 70 and 71.



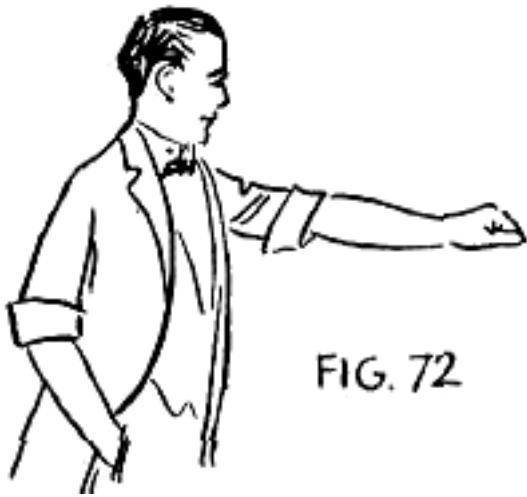


FIG. 72

Keep eyes on left hand, but very obviously place right hand in right trouser's pocket.

Figure 72.

"Now, all I have to do is to squeeze the left hand, and the silk will disappear."

Finger Palm celluloid egg in right hand and bring hand out of pocket. Audience must not be aware that you have something in right hand now.

Look at audience and say:

"Pardon me, but there seems to be come suspicion passing around the audience as to the legitimacy of the vanish. No, madam, the handkerchief has not vanished yet."



FIG. 73

Open left hand and allow handkerchief to hang suspended by one corner from thumb and base of first finger. Keep back of right hand to audience to conceal finger-palmed celluloid egg.

Figure 73.

(32-17)

"I am afraid you are not watching closely enough. I will just compress the handkerchief again."



FIG. 74

Tuck silk into opening in celluloid egg with first and second fingers of left hand.

Figure 74.

When all of silk is in egg, close left hand around egg and bring it away from right hand. Turn back of left hand to audience to conceal egg.

Show right hand empty, reach into right trouser's pocket, and remove key.

"I touch the hand with this Magic Key."

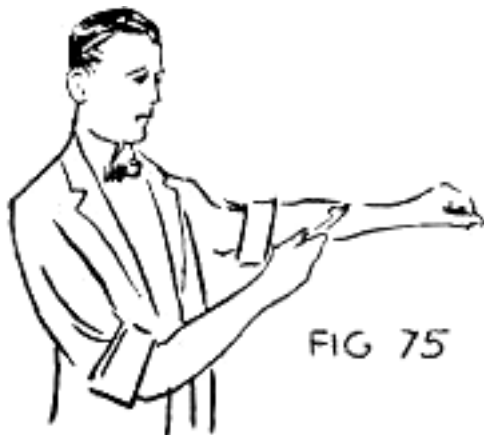


FIG 75

Touch left hand with key several times.

Figure 75.

"And we find that the handkerchief has mysteriously transformed itself into an egg."

As you say this, turn left hand and show egg.

Figure 76.

"Which goes to show the power of this magic key. I am often asked why I do not show how to do a trick once in a while, so I think at this stage I will take you into my confidence and show you how to change a handkerchief into an egg. You will be able to puzzle your friends, neighbors, relations, and perhaps, vast audiences. To begin with, you get a key, something like this one. Perhaps you already have a door key. Place the key in your pocket."

So saying, place the key in your right trouser's pocket and remove hand again.

"The next article you will need is an egg."

Transfer celluloid egg to right hand but do not expose opening in it. Place left hand casually in your left coat pocket.

Figure 77.

"Now, this egg is peculiar. While it appears to be a real egg, it really isn't."



FIG 77

Turn egg over, exposing the hole in it.

Figure 78.

"It is just a hollow egg with a hole in it, into which a handkerchief can easily be tucked."

(32-18)





Finger Palm real egg in left hand and remove hand from left coat pocket. With left fingers draw silk out of celluloid egg and hold in position shown in Figure 79.

"All you have to do is get a silk handkerchief about this size and hold it in your left hand, and then use this hollow



Hold handkerchief suspended from left hand and show egg as in Figure 80.

"Of course, the audience is not supposed to know that you have this egg, so keep it hidden behind your fingers this way."



Turn left side partly toward audience. Bring left hand over to right and cover hollow egg.

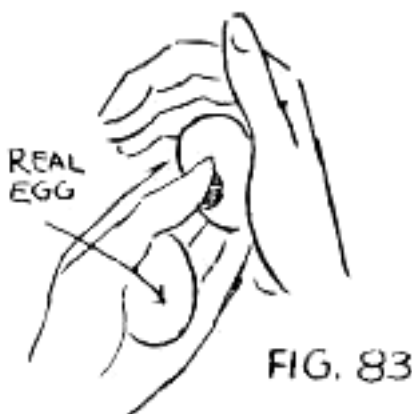
Figure 81.

"Now tuck the silk into the opening of the egg."



Turn right side of body toward audience. Keep hands together so that you do not expose real egg in left palm. Tuck silk into hollow egg with right hand.

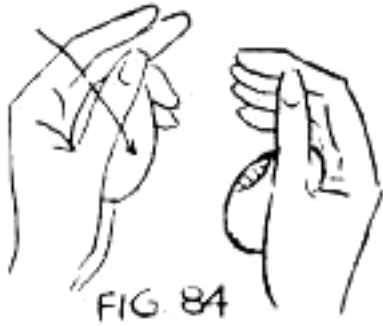
Figure 82.



Palm hollow egg in right hand.

Figure 83.

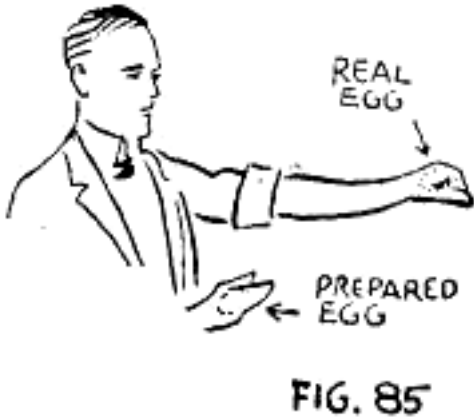
REAL EGG



Bring right hand away from left, concealing hollow egg. Expose real egg in left hand. Audience believes this to be hollow egg into which you tucked the silk.

Figure 84.

"There the silk is in the egg. Of course, you don't show the egg yet until you get the key. We use the key just to make it sound like real magic."



Turn your left hand over to conceal the egg, and hold left arm extended out. Bring right hand downward to right trouser's pocket to get key.

Figure 85.

(32-19)

As you pick up key from bottom of pocket with right fingers, force the hollow egg into upper corner of pocket with right thumb. As you bring key out of pocket, turn pocket out to show it empty.

"Of course, using this key is merely good showmanship. It looks good and gives the impression that you are a magician. So, then, we touch the left hand in this way."

Touch back of left hand with key or place key on hand. Then remove key and replace in pocket, turning pocket in at same time. Show right hand freely before and after doing this so that audience can see nothing is concealed in it.

"Then turn your hand over and show the egg."



Turn left hand over and show egg. It is the real egg, but audience believes it to be the hollow one.

Figure 86.

"It is marvelous, isn't it? However, be careful that you hold the egg with the thumb as I do, keeping the opening against your hand. Were you to expose the opening, your success as a magician would be nil. Of course, should any suspicious personage of a villainous nature ask to see the other side of the egg, then just hit the egg on a glass."



Hit egg on glass to break it. Break the shell apart and allow contents to drop into the glass to show that the egg is REAL.

Figure 87.



"Break the egg and show them that it is a real one."

FIG
87

* * * *

A "SUCKER" HANDKERCHIEF VANISH

This vanish is very effective because of its impromptu nature.

EFFECT:

Performer rolls handkerchief in his hands and pretends to place it in his closed left hand. His right hand goes into his trouser's pocket and then comes out again. The audience believes that the handkerchief was placed in his pocket, instead of his left hand. Performer then opens left hand and shows that silk has not vanished yet. He rolls up silk again, pushes his right forefinger through his left palm, and the silk is found to have mysteriously vanished.

PARAPHERNALIA:

1 -- A silk handkerchief, about 13 inches square.

To Perform:

Come forward with handkerchief.

"Strange as it may seem, I hold in my hand not an ordinary silk handkerchief, but a most remarkable one. It comes and goes in a way which the closest eye cannot follow. Though many people have watched very carefully, yet when I roll it up in my hands, they have never been able to see where it vanished. So watch closely, because the closer you watch--the closer you watch."

Roll silk up between hands as explained above.

See Figures 64 to 70.

Separate hands as in Figure 71.

Keep eyes on left hand and place right hand in pocket. Move hand about a little and then withdraw it. Audience is led to believe that you placed silk in pocket.

"Now, when I open my left hand, you will find that the handkerchief has mysteriously disappeared."

Pretend to hear someone talking in audience. As a rule, you do hear people whispering that handkerchief is in your pocket.

"What's that? I placed it in my pocket? No-no. You see it really hasn't gone yet."

Grasp corner of silk with left thumb and allow silk to hang from hand as in Figure 73.

This gets a laugh and squelches a few of the "wise ones."

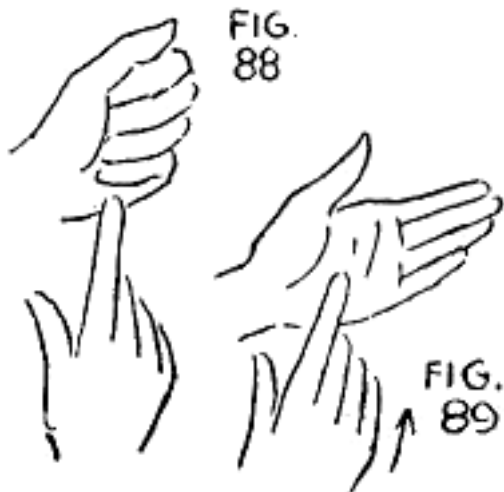
"It is a very peculiar thing, but when I roll up a handkerchief and place it in my left hand....."

Roll up handkerchief again into small ball. Pretend to place it in left hand, but in reality keep it in right hand. Right thumb may be brought down against it to hold it.

"And then place my right hand in my pocket....."

Place right hand in pocket. With thumb, force silk into upper corner of pocket. Then grasp bottom of pocket and turn it out to show it empty. Also show right hand empty.

"People say, 'Oh, he put it in his pocket.' Now, that wouldn't be magic if you would catch me at it. It is so much easier to take the first finger of the right hand and place it against the left hand and push the handkerchief away in this fashion."



Place right forefinger against left hand, palm of latter toward audience.

Figure 88.

Open left hand and push right finger over palm quickly.

Figure 89.

Show hands empty on both sides, fingers wide apart.

* * * *

A ONE-MAN HANDKERCHIEF VANISH

This effect is so named because it is performed to fool one person while the rest of the audience sees and enjoys the perplexity of the one person. Finally, however, the whole audience is puzzled. A good comedy vanish.

EFFECT:

Performer asks a spectator to assist him. He shows a glass tumbler on the table and then covers it with a cardboard tube. Performer takes a silk handkerchief and stands close beside spectator. He tells assistant to watch carefully as he vanishes handkerchief. He throws silk back over spectator's shoulder to vanish it. Spectator is puzzled but rest of audience is very much amused by the vanish. In the meantime, performer's assistant has picked up silk and placed in tumbler with cover over it. Performer goes to tumbler, lifts tube, and shows perplexed spectator that silk has appeared there. Magician then says he will repeat the trick as this spectator may not have understood it. He covers glass again after taking silk from it, and then proceeds to roll silk up between his hands. It suddenly disappears from his hands so that neither the spectator nor the rest of the audience know where it went to. Magician then uncovers glass again and there once more is seen the silk.

PARAPHERNALIA:

- 1 -- Two silk handkerchiefs, each about 13 inches square -- must be exactly alike.
- 2 -- A drinking glass.
- 3 -- A cardboard tube about three inches higher than the glass and big enough in diameter to slip over the glass easily.
- 4 -- A metal clip to hold one handkerchief concealed in tube.
- 5 -- A handkerchief "pull."

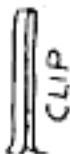
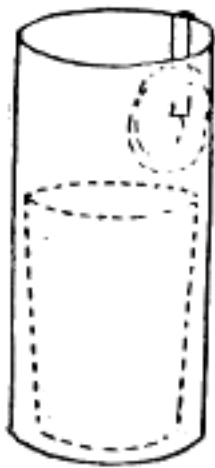


FIG 90

To Prepare:

Make the tube of cardboard glued together. Get an ordinary metal clip and place it at top of tube. Tuck silk up into it just far enough to be held securely but to be released easily. Figure 90 shows arrangement of tube when it is placed over glass.

Adjust handkerchief "pull" at right side of body. Place it in right lower vest pocket so that you can reach it easily.

Have glass and tube on table at right of stage. (Right of stage is to your right as you face audience always.)

This effect requires an assistant to help you.

To Perform:

Have a gentleman come up from audience.

"I need a committee of one to help solve the mysterious wanderings of this magic silk. I believe, sir, that you possess an eagle eye. To begin with, I use a glass—a drinking glass --and a paper tube."



FIG 91

When spectator has come up, pick up tube with right hand. Place fingers inside and thumb outside so that you conceal the silk inside. Hold tube up so that all can see it, showing the inside empty.

Figure 91.

"A tube that fits nicely over the glass, commonly referred to as papering a glass house."

Replace tube over glass.

"Now, for the mystery of Whither, Whither, Little Silk."

Have gentleman stand toward left side of stage, facing left. The table with tube and glass are back of him and farther to rear of stage. Go over and stand at left side of spectator. Start rolling up silk between your hands. Figure 92 shows position of spectator and yourself as seen by audience.

"Strange, isn't it—that when you roll up a silk in your hands it becomes smaller?"

Roll up silk and get it into closed left hand. Raise right hand upward and backward and strike left hand several times.

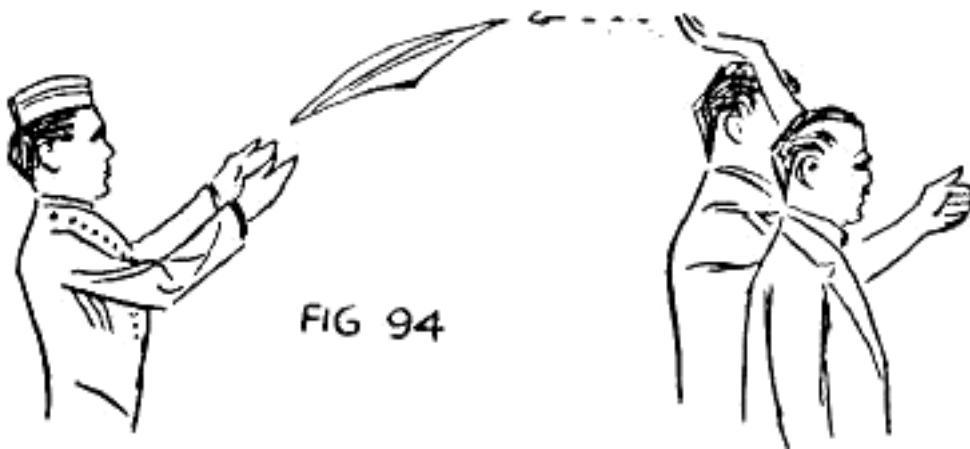
Figure 93.

Then open left hand and show silk.

"The magic influence doesn't seem to be working very well."



FIG 93



Roll up silk again, retaining it in right hand this time. Pretend to leave silk in left hand again by closing left hand and removing right. Raise right hand upward and backward as before and throw silk back of you into hands of your assistant.

Figure 94.

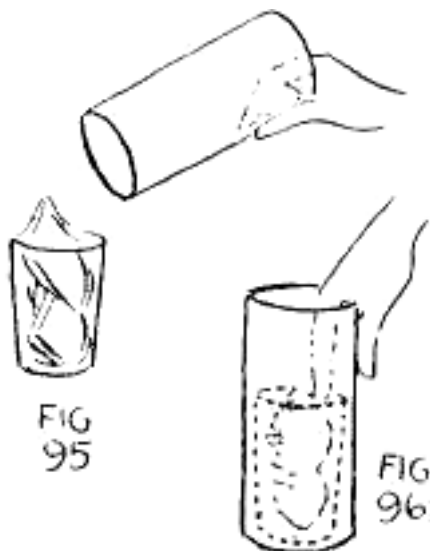
Strike left hand with finger-tips of right as hand comes down quickly.

Open left hand and show that silk has vanished. Show both hands freely.

The moment assistant gets silk, he raises tube, places silk in the glass, and replaces tube so that audience can see.

"There, that is much better. The silk has gone."

The spectator is always bewildered, and the audience finds his perplexity very amusing. This trick has even fooled clever magicians.



Now, go over to the table. Remove tube and expose silk in glass.

Figure 95.

Remove silk and cover glass again with tube. As you place tube down, force concealed silk from clip with right fingers and push it into glass.

Figure 96.

"Odd, sir, the way the little silk wanders around."

Go back to position at left of spectator again. Hold silk in left hand and get "pull" into right. Stand far enough away from spectator so that he cannot see "pull."

"No doubt, sir, you were watching too closely before and would like to look closer this time. It is really very simple. All I really do is wave the silk a bit between my hands."

Work silk into "pull" and pretend to place silk in left hand. Close left hand. Release "pull" from right hand and let it fly back into place under your coat.

"Then I strike the left hand containing the handkerchief with the fingers of the right hand."



Raise right hand as before and strike left hand.

Figure 97.

"This causes the silk to enter the psychic world and disappear."

Open left hand and show it empty. Then show both sides of right hand.

(32-24)

Go back to table. Uncover glass and show silk inside.

"And thus the little wanderer finds its way back into the glass again."

Remove silk from the glass with a jerk and a flourish.

* * * *

THE SYMPATHETIC SILKS

A beautiful problem with silks. A great favorite of Houdini. In various forms, this problem has graced the acts of a number of professionals. I present it to you in its simpler form.

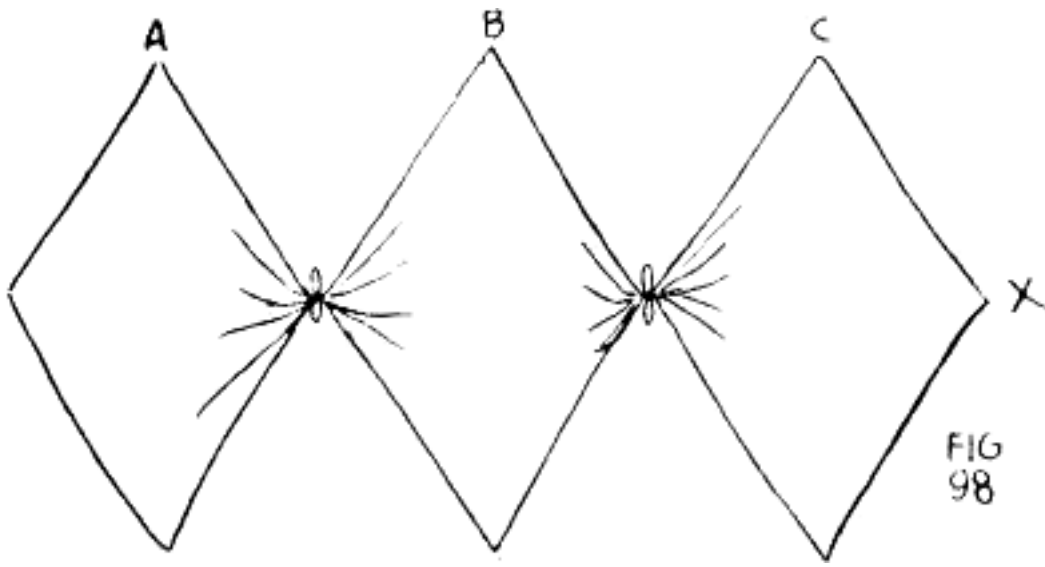
EFFECT:

Six silks are shown separately. Three are placed on the seat of a chair. The other three are knotted together by the corners. Performer explains that a sympathetic bond exists between the two sets of silks. Because one set was tied, the other set also ties itself. The three separate silks are lifted from the chair and are found to be tied in the same way as the tied set. Magician unties these silks, and when he picks up the other three, they are found to have mysteriously untied themselves also.

PARAPHERNALIA:

1 - Six silk handkerchiefs, preferably about 27 inches square and bright red for flash in the effect. Large silks are particularly desirable for stage use. For parlor work, pocket handkerchiefs may be used.

SECRET AND PATTERN:



To Prepare:

Tie three of the silks together as in Figure 98.

Hold the silks up by the corners A, B, C with the knots to the rear. On the left place a single silk, and on the right, two single silks.

Arrange silks in this order on a table or chair so that they can be easily picked up without exposing knots. Audience must believe that all silks are separate.

To Perform:

Pick up silks and hold in left hand in order mentioned above. To call attention of audience to separate silks with-



FIG 99

out appearing to do so, casually take the two separate silks in your right hand, jerk them up and down as if to straighten, and replace them in left hand.

Figure 99.

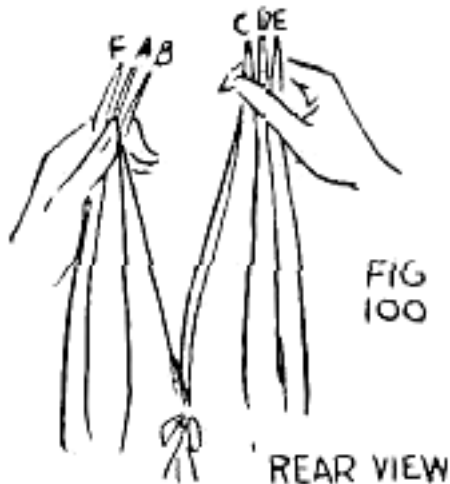


FIG 100

Now count the silks aloud, passing them from left to right hand. Keep hands close enough together so as not to expose knots.

Figure 100 shows view toward yourself.

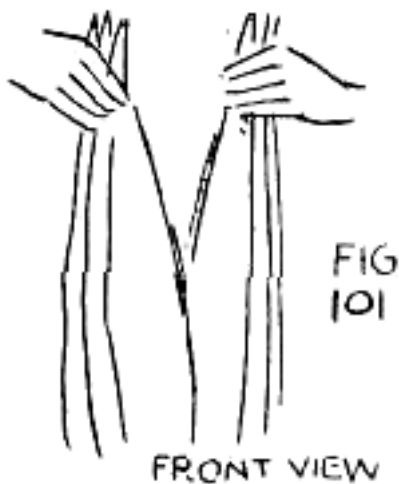


FIG 101

Figure 101 shows silks as audience sees them. Because top and bottom corner are separate, spectators think the silks are separate.

When you come to last silk, lift it away from others, snap it up and down with left hand, and then place with others in right hand. Now place silks back in the left hand, getting left single one over on right side with other two single silks.

"Six silk handkerchiefs"

Take the three prepared handkerchiefs and place them on seat of a chair as you would if they were separate. Bunch them up a little.

Figure 102.

Tie two of the single silks together by the "Fade-Away-Double-Knot" method, taught to you earlier in this lesson. Handle the silks carefully so that they do not untie prematurely and tie the third single silk to one of the other two.

Figure 103.

Bunch the silks up a little and drop them to the floor or to the seat of another chair.

"Peculiar to these silk handkerchiefs is the bond of sympathy that lies between them. What one bunch over here does, the bunch over there imitates. We started with six single silks. I knotted these three together."

Reach down and pick up first bunch of silks, A, B, C, by corner X (see Figure 98). Jerk them upwards, showing a chain of three silks knotted together.



FIG 102

"And sympathetically, these three knotted themselves. I shall untie them."

(32-26)

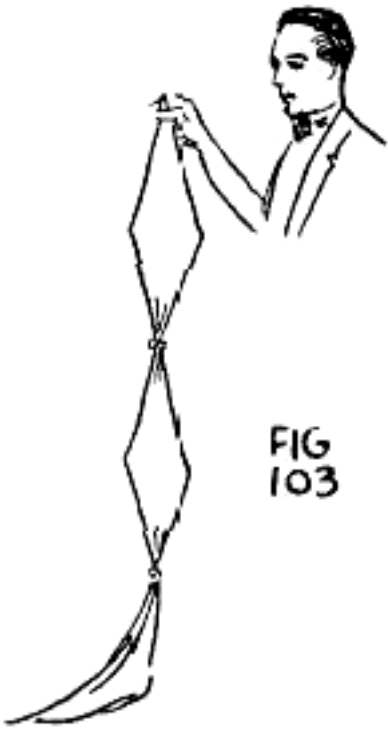


FIG
103

Untie the three knots and drop the silks, one at a time, on a chair.

"And in sympathy with these unknotted silks, these three over here become unknotted."

Pick up a corner of one of the other set of silks and jerk it upward quickly to untie it. In the same manner pick up the second and untie it--then the third.

Another Counting Version



FIG
104

There are a number of ways of showing silks separate in the beginning. The method described is very easy. Another way is to hold silks as in Figure 104. A, B, C, the knotted silks, in crotch of left thumb; D between first and second fingers, E and F between second and third fingers.



FIG
105

Bunch corners together so that they appear to be held together.

Figure 105.



FIG
106

Count silks aloud, one at a time. Pick up E first at upper corner with right hand and shake it.

Figure 106.

"One."

Take F in right hand and shake both together.

"Two."

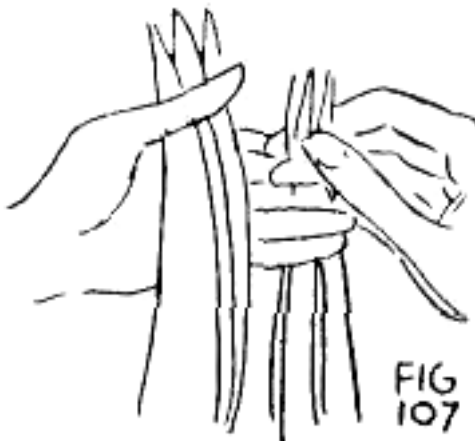
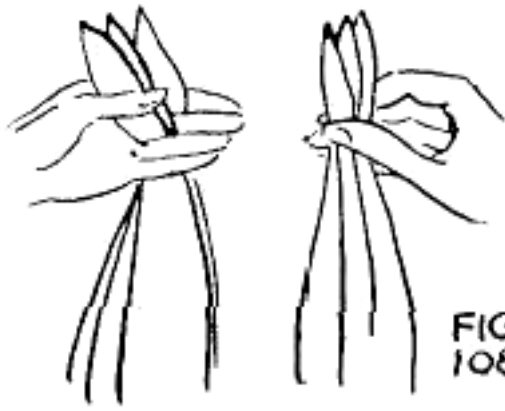


FIG
107

Bring right hand to left hand to pick up third silk apparently. Quickly replace E and F between second and third fingers of left hand.

Figure 107.



With movement of left arm swinging toward right, pick up A, B, C in right hand and shake the three together.

Figure 108.

"Three."

The swinging of the left arm and flourishing of the right as you quickly exchange silks from left to right hand makes it appear to the audience that you merely took a third single silk from left hand into right.

Place the three knotted silks--A, B, C--on chair seat. Continue to count the other three silks.

(32-27)

"Four, five, six."

Now proceed with the experiment as before.

Using a Chair Display for Counting Silks

In this method, the silks are hung up in such a manner as to make the knotted silks look single.

First, sew very small rings at top corners of A, B, C, D, E, F.

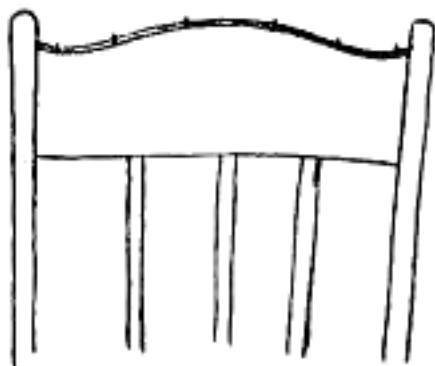


FIG. 109

On top of a chair, drive six small brads equal distances apart. Drive them just far enough in to hold securely with enough projecting to hold rings of handkerchiefs.

Figure 109.

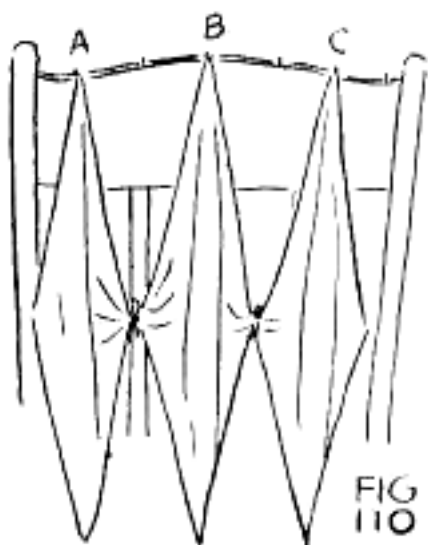


FIG. 110

Hang rings of A, B, C on first, third, and fifth brads.

Figure 110.

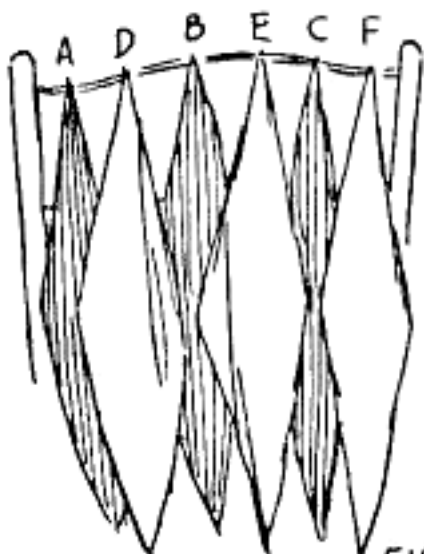


FIG. 111

Hang rings of D, E, F on second, fourth, and sixth brads.

Figure 111.

D and E cover the knots, and to all appearances, there are six single silks hanging on the chair.



FIG. 112

Pick up corners C, B, A and jerk them downward suddenly to free them from other silks. Practice this move so that you perform it naturally as if you were handling single silks.

Figure 112.

Count the silks—one, two, three—as you pick them up. Then place them on the seat of a chair.

Then continue your count as you pick up the other three in a similar manner. Proceed with this experiment from this point.

Varying the Effect

A good variation of the Sympathetic Silks is this:
After counting the knotted set as if they were
separate, place them on a chair. Then tie the three
single silks into a chain,

(32-28)

and place them on another chair or on the floor. Jerk the latter set up suddenly to untie the magic knots, and show that the silks have untied themselves. Pick up the first knotted set by corner X and show that knots have appeared in this set.

* * * *

ELUSIVE SILKS

A pleasing experiment with silks, good for stage or close work. Though very easy to perform, it is effective. This introduces to you a very handy piece of apparatus known to Magicians as a Changing Bag.

EFFECT:

A small bag, attached to a handle and resembling a church collection bag, is turned inside out and shown empty. Performer then turns it back right side out and suddenly a red handkerchief appears in it. This is given to a spectator, who is asked to place it in the bag again. He does so, and the handkerchief changes instantly to a green one. Here follows a series of appearances, changes, and disappearances which work into a pleasing routine.

PARAPHERNALIA:

1 -- A Petri-Lewis Changing Bag.

We can supply you with one at a reasonable price. There are two sizes of Changing Bags on the market. This effect may be performed with the larger size bag for which larger size silks should be used. I recommend using the smaller one, however, for a neater performance.

2 -- Four silk handkerchiefs - two red, two green - about 13 inches square. You may use any colors you desire, but there must be two of one color and two of another.

HOW TO HANDLE A CHANGING BAG:

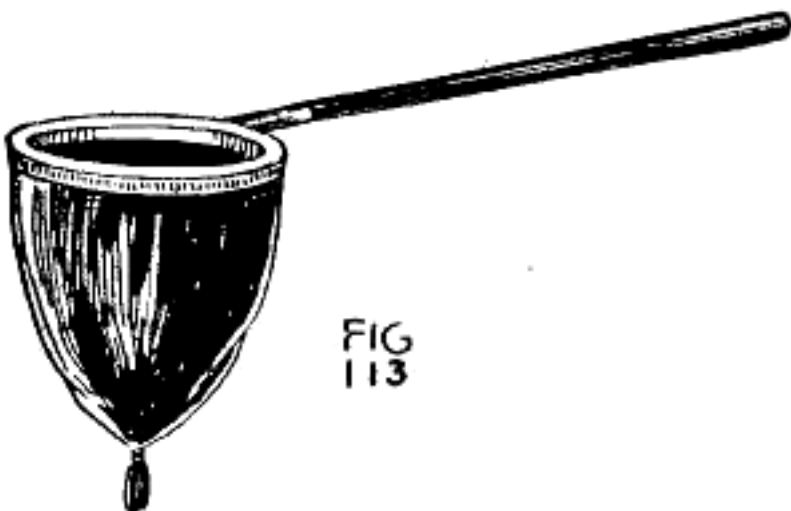


FIG
113

Figure 113 shows the Changing Bag as it looks from the outside. The top is a metal ring to which the handle is attached. The bag is of red velvet lined with black. There is a tassel at the bottom.



Figure 113A shows the way in which the inner wire in the bag operates to change the compartments in the bag. It swings downward from side to side in the bag so that it cannot be seen.

(32-29)

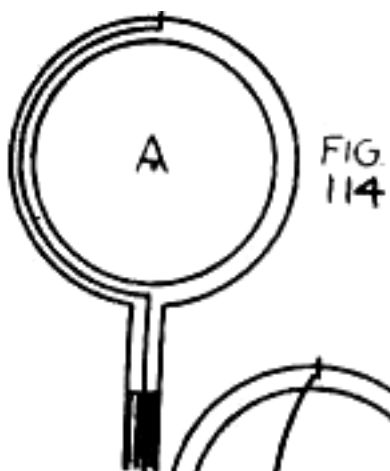


FIG. 114

Figures 114, 115, and 116 show diagrams of the operation of the inner wire as seen when you look down into the bag.

First, there is compartment A with the wire flat against one side of the bag. Then wire swings downward inside of bag toward other side, closing up compartment A and revealing compartment B.

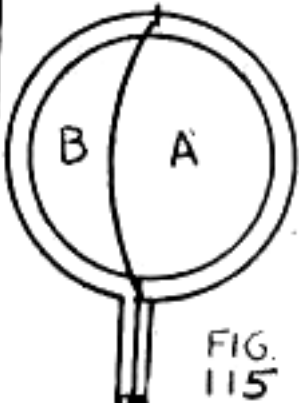


FIG. 115

The wire runs into the handle and it is operated by turning the handle forward or back as required.

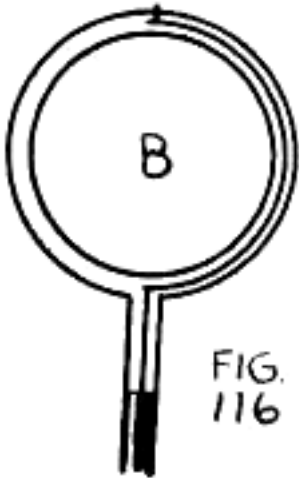


FIG. 116

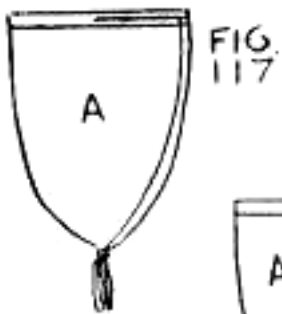


FIG. 117

Figures 117 to 121 show the working of the bag diagramed from a cross section view.

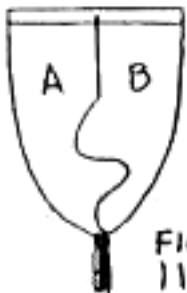


FIG. 118

First, there is compartment A. Then wire is dropped down with the cloth partition attached to it, making compartments A and B. Wire swings completely over to other side of bag, closing compartment A and leaving compartment B. If an article, say a silk handkerchief, is placed in compartment B -Figure 120--a slight turn of the handle of the bag will vanish it as shown in Figure 121.

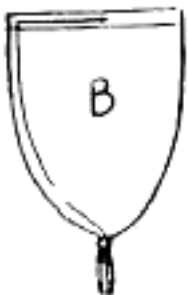


FIG. 119

Thus, an article may be placed in A or B and vanished and made to appear at will. When an article is vanished, the bag may be turned inside out and shown empty. Color changes are accomplished by placing a red silk in one compartment and a green one in the other. When change is made, mouth of bag must be kept turned from audience so that movement of wire will not be detected.

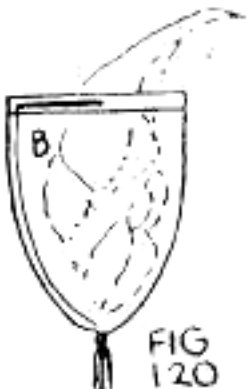


FIG. 120

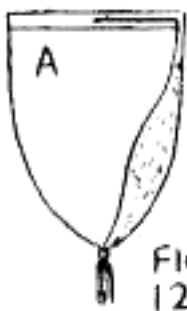


FIG. 121

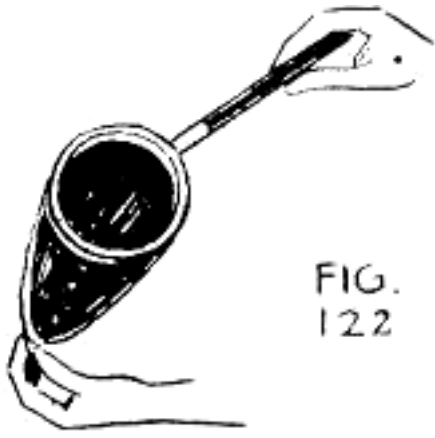


FIG.
122

To handle the bag easily, hold it as in Figure 122. Handle is in right hand—left hand grasps tassel at bottom of bag. Keep mouth of bag turned enough toward you to conceal movement of wire from audience.



FIG
123

Raise bottom of bag a little and turn handle a little in whichever direction you desire wire to go.

Figure 123.

(32-30)

The Changing Bag has many possibilities, not only for silk work, but for MIND READING. Blank slips of paper may be placed in one compartment of bag and the real slips may be collected in the other. The change is made and the blank slips poured out onto a plate before the audience. Bag is shown empty and tossed offstage, where assistant takes it. He can then change the bag again, remove the real slips and prepare the questions for you.

It may also be used for Forcing Numbers. Have small disks or cards with numbers, say one to twenty, on them in one compartment. Have twenty cards all with one number on them in the other compartment. Show the numbers in the first compartment, then make change, and have spectator select from second compartment where numbers are all alike.

Now, for the Elusive Silks:

SECRET AND PATTERN:

To Prepare:

Place a green silk in upper corner of right trouser's pocket, and a red silk in upper corner of left trouser's pocket. Arrange so that pockets can easily be shown empty.

In compartment B of bag place a red silk and on top of this, a green one. Change partition so that silks are concealed and compartment A is revealed.

To Perform:

Come forward with bag. If you are on a stage, have a spectator come up to help you. Place him at your left.

"Last Sunday when I was in church, I noticed that a collection was being taken up in little collection bags like this one."

Push the bag here and there as if you were making a collection.

"When I got home, I found that I had one of these collection bags under my coat. Of course. I was puzzled as to how it got there, but here it is. I have the bag - also an empty pocket here."

Turn left trouser's pocket out and show it empty. Replace it and force red silk down into pocket.

"And an empty pocket there."

Turn right pocket out and show empty. Replace, forcing green silk down from corner into pocket.

"With empty pockets and a collection bag, there is no reason why I shouldn't pass around among such a liberal congregation."

Turn bag inside out and back again to impress on spectators fact that bag is empty.

To a spectator, then to audience:

"Do you mind, sir, if you and I take up a little collection? He's in favor."

Push bag out in front of you and to the right to imaginary spectators.

"Anything from money to silk dresses appreciated."

Bring bag back toward you with mouth turned from audience. Make change.

Reach in and remove the green silk. Make change again to conceal B again and reveal empty compartment A. Push bag inside out to show empty.

"Ah, silk! Will you take it, please, sir, and then place it back in the bag?"

Spectator takes silk and places it in bag – compartment A. Make change, concealing A with the green silk and revealing B with the red one. Ask spectator to remove it again and he takes out a red silk.

"Please take it out again, sir. Now, it's red."

Show bag empty by pushing inside out.

"There's something suspicious about this collection business."

Reach into right pocket and remove green silk.

"You will note that things placed in the collection bag also find their way into the collector's pocket. Well, back it goes into the bag."

Make change, then place green silk with other green one in compartment A. Make change and show bag empty.

"In again, out again, gone again. Reach into my pocket, sir."

Have spectator reach into your left trouser's pocket and remove the red silk."

"What's this? A red one? Somebody is playing tricks on us."

Turn bag inside out again to show it empty. Do this suddenly as if you wanted to make sure that green silk had vanished.

"Now, just place both the silks into the bag."

Spectator places the two red silks into the bag. Make change and remove one green silk, then the other.

"Now, they're green -- both of them."

Show bag empty again.

"So we'll place them both back into the bag again."

Make change and place the two red silks with the two green ones. Make change again. Turn bag out to show it empty.

"Now, they're gone -- so we're back where we started."

Put bag aside and go into next trick.

A GOOD COMEDY ENDING:

The effect can be carried through another step to a surprise finish. Have a nickel in your pocket or attached to right edge of coat with a clip. Get it into right palm and drop it into bag without being detected by audience. Show hand empty, then reach into bag and take out nickel. Show it to audience and say, "Which makes the sum total of our collection ONE NICKEL."

Another ending is to have a watch and five one-dollar bills, all in a wad with a rubber band around. Have this parcel in right coat pocket, and during excitement over the vanished silks, palm the parcel and drop it into the bag. Show right hand empty and reach into bag. Take rubber band from parcel and remove one dollar bill. Say, "However, not so bad at that, as I have a collection system all my own." Take out other four bills, one at a time, and finally produce watch. Look at spectator knowingly and say, "My, how time flies."



TARBELL SYSTEM, INCORPORATED. Chicago.

* * * * *

The paraphernalia described in this lesson can be obtained from the Tarbell System at the following prices, postage prepaid.

26" Red Silks	\$1.25
Celluloid Egg60
Changing Bag	5.00

* * * * *

LESSON 33

Sleight of Hand with Cigarettes and some clever Cigarette Effects taught you in your next lesson.

CIGARETTE MAGIC

This lesson is devoted to Sleight of Hand with cigarettes. Because the cigarette is in such common use, cigarette magic is popular. It also permits of working with lighted cigarettes and thus makes this kind of magic doubly mysterious.

You learned some excellent effects with cigarettes in Lesson 2, in which the Thumb Tip was used to accomplish the tricks. In this lesson, you make use of a Cigarette Pull and a clip, but most of the work depends wholly on digital skill. You learn some very important moves.

I must emphasize again the importance of NATURALNESS. The size and shape of a cigarette make it a little more difficult to handle naturally than some other objects. You must study your moves carefully before the mirror, watching your ANGLES OF VISIBILITY and striving for natural movements.

I might mention here a compliment to my work which pleased me greatly. A gentleman, in speaking of my work in Magic, said, "I hardly know whether to call Dr. Tarbell a Magician or not. He doesn't seem to use trickery. The things he does may not be according to natural law, but they certainly seem to happen in a natural manner."

A reputation like that is worth working for. I want you to work for it, remembering always that you are not a mere trickster but a REAL MAGICIAN performing miracles in a natural manner.

Cigarette Manipulation

THE PUSH-IN VANISH

EFFECT:

Cigarette is pushed into closed left hand. When hand is opened, cigarette is found to have vanished.



FIG. 1

To Perform:

Hold cigarette as in Figure 1. Thumb and fingers of right hand grasp cigarette and bring it to closed left hand.



FIG. 2

Push cigarette into left hand.

Figure 2.

Bring hands apart. Open left hand and show cigarette in it.

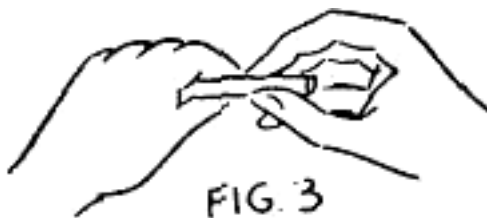
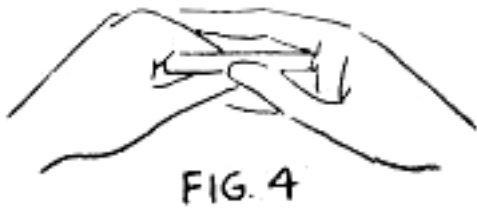


FIG. 3

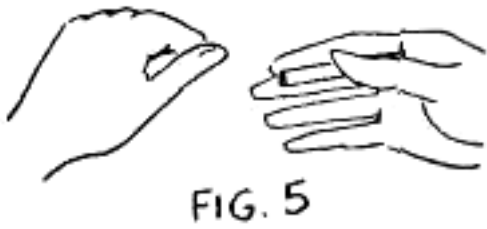
Place cigarette against left fist again. Instead of pushing cigarette into hand, however, run first two fingers and thumb of right hand along cigarette toward left hand.

Figure 3.

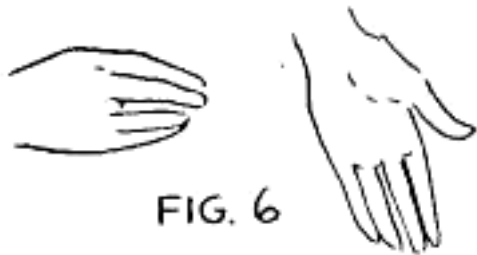


Slide right fingers over left forefinger.

Figure 4.

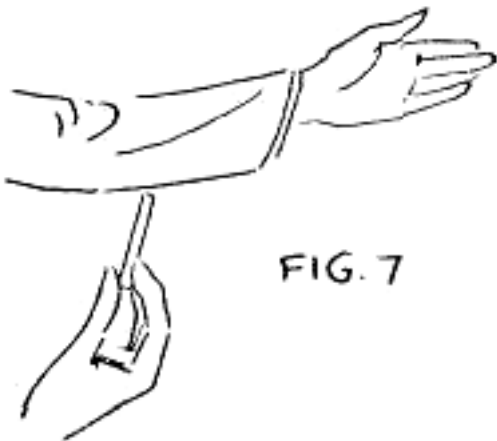


Place right thumb against cigarette. Draw right hand away from left, concealing cigarette as shown in Figure 5. If you do these movements properly, the illusion of pushing cigarette into closed left hand is perfect.



Now raise left hand, open it, and show that cigarette has vanished.

Figure 6 shows view toward audience.



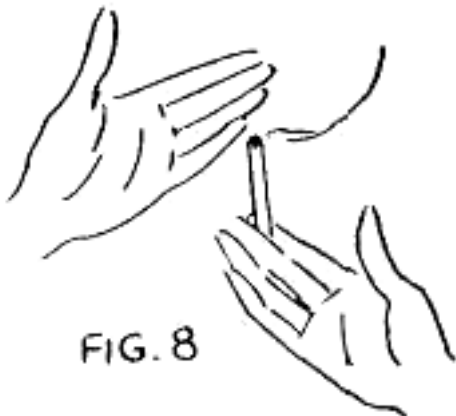
Produce cigarette from left elbow. To do this, reach behind elbow, get cigarette into position at tips of right fingers, and bring cigarette out.

Figure 7.

THE PICK-UP VANISH

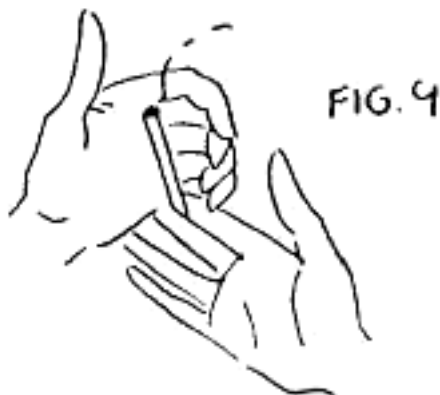
EFFECT:

Performer holds a lighted cigarette in right hand. He closes left hand around it and takes it away from right. Suddenly he opens his left hand and cigarette has vanished. It is then produced from left knee.



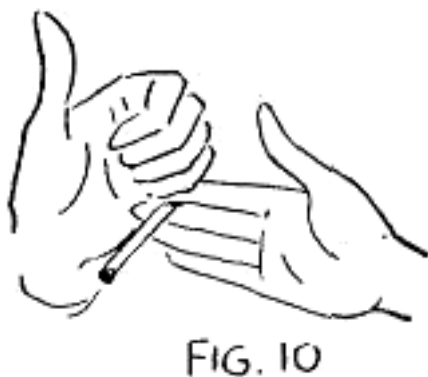
To Perform:

Hold cigarette as in Figure 8. Lighted end of cigarette is up and it is grasped between first and second fingers of right hand. Hold palm of hand toward audience so that cigarette is plainly visible.



Now turn palm of right hand toward yourself. Curl left hand around cigarette.

Figure 9.



As you close left hand, supposedly around cigarette, drop cigarette into horizontal position, extending from right fingers.

Figure 10.



FIG 11

Close left hand and draw it away from right. Curve right fingers with cigarette toward right palm. Keep back of right hand to audience and be careful that end of cigarette where you grasp it is not exposed.

Figure 11.

(33-2)

Open left hand and show cigarette has vanished.
Produce it from behind right knee.

NOTE:

The smoke coming from the lighted cigarette may give you away if you are not careful. The hand concealing the cigarette should be kept in slight motion to scatter the smoke.

THE PIVOT VANISH

EFFECT:

Cigarette is patted into the left fingers, and the left hand is closed around it. In a moment the cigarette is found to have disappeared from left hand.

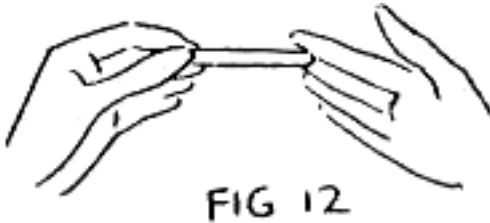


FIG 12

To Perform:

Hold cigarette in left hand at tips of first and second fingers and thumb. With tip of second finger of right hand, pat cigarette, pushing it into left hand about half an inch.

Figure 12.



FIG 13

Continue patting cigarette into left hand a little at a time until only about a quarter of an inch extends beyond left fingers.

Figure 13.



FIG 14

With second finger-tip of right hand, press outward on end of cigarette. This pivots it into right hand.

Figure 14.



FIG. 15

Cigarette goes just inside crotch of thumb. Place thumb against it to hold in place.

Figure 15.

Hold right hand naturally, back to audience. Close left hand as though it holds the cigarette, then open it and show cigarette has vanished.

FRONT AND BACK HAND PALM

EFFECT:

Performer shows both sides of right hand empty. Then suddenly he produces a cigarette at his finger-tips.



FIG 16

To Perform:

This may be done as a continuation of various cigarette vanishes. If you do it following the Pivot Vanish, allow cigarette to pivot into position shown in Figure 16. The end of it goes right into crotch of thumb.



Cigarette can then be easily grasped in crotch of right thumb.

FIG. 17

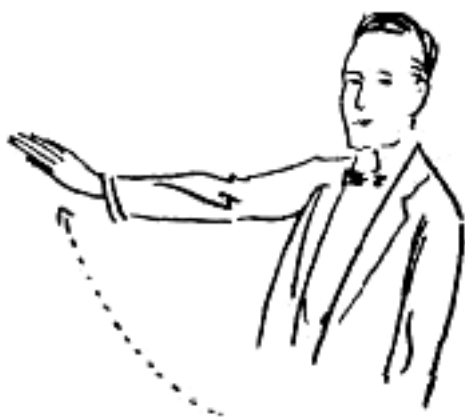
Figure 17.



Drop right hand to side. Keep back of hand to audience.

Figure 18.

FIG 18



Then raise right hand, still keeping back of it to audience.

Figure 19 shows hand as audience sees it.

FIG. 19



Figure 20 shows palm of hand away from audience with concealed cigarette.

FIG. 20



Now you are to turn hand over quickly to show palm empty to audience. As you turn hand, force end of cigarette between first and second fingers.

Figure 21.

FIG. 21

THUMB CONCEALS CIGARETTE



Press tip of right thumb against fingers and other end of cigarette to conceal it. Palm may now be shown empty. Turning of hand must be done quickly and naturally as if you actually had nothing in your hand.

Figure 22.

FIG. 22

FIG. 23



Turn your hand to show back again, and as you do so, pull cigarette back between first and second fingers to palm of hand again.

Figure 23.

Do this back and front movement two or three times. Then as you show palm for the last time, get cigarette to fingertips by pivoting lower end upward, and produce cigarette.

This may be performed with a burning cigarette. Be sure to open fingers wide enough when you pass the burning end between your fingers so that you will not burn yourself.

THE THROWING VANISH

EFFECT:

A lighted cigarette is thrown into left hand. Hand is closed and then opened, and cigarette is found to have disappeared.

(33-4)



FIG 24

To Perform:

Hold cigarette in right hand between tips of first and second fingers. Have it lighted.

Figure 24.



FIG 25

Make a throwing motion toward left hand. As you do so, curl right fingers in to palm and press end of cigarette against crotch of thumb. Use left hand as a screen for these movements.

Figure 25.

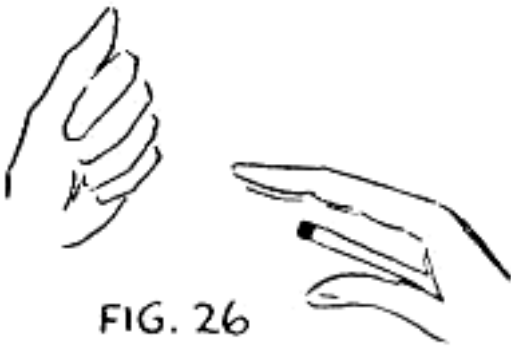


FIG. 26

Close left hand as though holding the cigarette and draw it away from right. Open right fingers, holding cigarette in crotch of thumb.

Figure 26.

Open left hand and show that cigarette has vanished. Then produce cigarette from left elbow. Or you may vary the production by turning back of left hand to audience and producing cigarette from behind it.

THE PULL-AWAY VANISH

EFFECT:

Cigarette is held in closed fist of left hand. Performer pushes it into left hand with his right. Yet when left hand is opened, cigarette is found to have vanished.

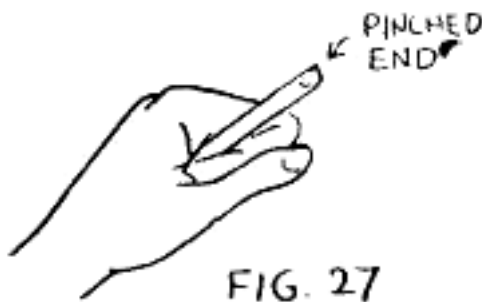


FIG. 27

To Perform:

Pinch one end of cigarette so that it is flat. Place it in closed left fist with pinched end upward.

Figure 27.



FIG. 28

Place first two fingers of right hand against end of cigarette. Grip pinched end firmly between first and second finger-tips.

Figure 28.



FIG 29

Push cigarette into closed left hand. To audience it must appear that you merely push cigarette with right fingers but do not grasp it.

Figure 29.

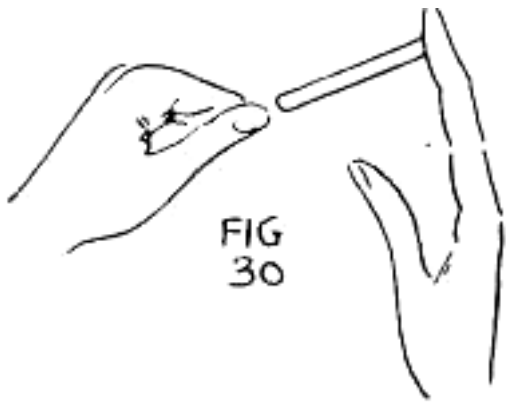


FIG
30

Draw left hand away as if you held cigarette in it. Cigarette remains gripped in right fingers. Hold it in horizontal position with back of hand to audience.

Figure 30 shows side view away from audience.

(33-5)

Curve right fingers inward to palm.

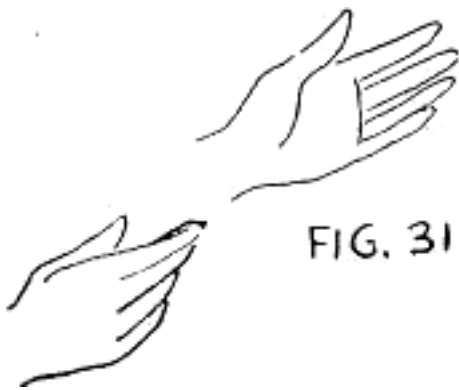


FIG. 31

Open left hand and show it to audience. Cigarette has vanished.

Figure 31.

TO VANISH CIGARETTE UP THE NOSE

Performer pushes cigarette up his right nostril and causes it to disappear.



FIG. 32

To Perform:

Place end of cigarette against right nostril.

Figure 32.

Slide first and second finger-tips and thumb of right hand up along cigarette to the nose. This gives the illusion that cigarette was slid up into nostril, but in reality it is grasped in right hand.



FIG. 33

Figure 33.

Remove hand from nose.

TO PRODUCE CIGARETTE FROM EAR

EFFECT:

Performer reaches up with right hand and takes a cigarette out of his right ear.

To Perform:

This is a pleasing continuation of the above vanish.



FIG 34

With cigarette pressed against first two fingers with thumb of right hand, reach up to opening of right ear.

Figure 34.

Slide fingers backward to end of cigarette and bring it out, apparently from the ear.

Figure 35.



FIG. 35

TO SWALLOW A CIGARETTE

EFFECT:

Performer pushes cigarette into mouth and apparently swallows it.



FIG. 36

To Perform:

Place end of cigarette against lips.

Figure 36.

Push fingers upward along cigarette as you did in pretending to put cigarette up the nose. Open mouth a little. When cigarette is concealed in right hand, remove hand from lips. Make a swallowing motion. Now produce the cigarette from under your vest.

VANISH AND PRODUCTION OF PAUL FUCHS

This is a beautiful effect in the hands of Paul Fuchs.

EFFECT:

Cigarette is placed in left hand and vanished. Both hands are shown empty, then cigarette is produced from behind left hand.

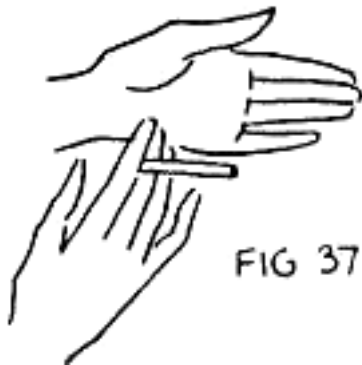


FIG 37

To Perform:

Hold cigarette between first and second fingers of right hand.

Figure 37.

Place left hand with back to audience over back of right hand to conceal cigarette.

Under cover of left hand, make the following moves with the right.



FIG 38

Allow cigarette to fall over second finger.

Figure 38.



FIG 39

Place third finger over cigarette.

Figure 39.



FIG 40

Release first finger and hold cigarette grasped only between second and third fingers.

Figure 40.

FIG 41

Curve fingers inward to palm of hand.

Figure 41.



Remove left hand and close it as if it held cigarette. Point right index finger at left hand.

Figure 42 shows hands as audience sees them.



FIG 42



Figure 43 shows view from rear away from audience.

Open left hand and show that cigarette has vanished.



FIG. 43

Place right hand up behind left, straightening out fingers which grasp cigarette. This is done apparently to show back of right hand, but in reality to manipulate cigarette. Place right forefinger over cigarette again, release third finger, and get cigarette into original position between first and second fingers.

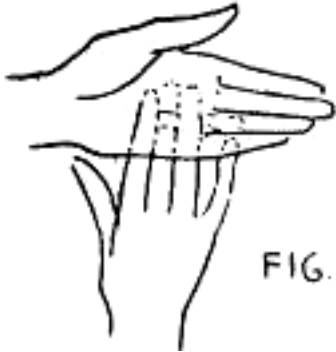


FIG. 44

Figure 44.

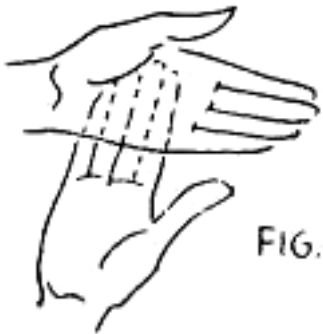


FIG. 45

Turn right hand to show empty palm to audience.

Figure 45.



FIG
46

Figure 46 shows view away from audience. Cigarette is held horizontally in back of right hand.



Separate hands and show them empty.

Figure 47.



FIG
47



Turn back of left hand audience and bring it down over right fingers far enough to conceal movements as you bring cigarette to thumb and finger-tips of right hand. Draw right hand away from left and produce cigarette.

Figure 48.

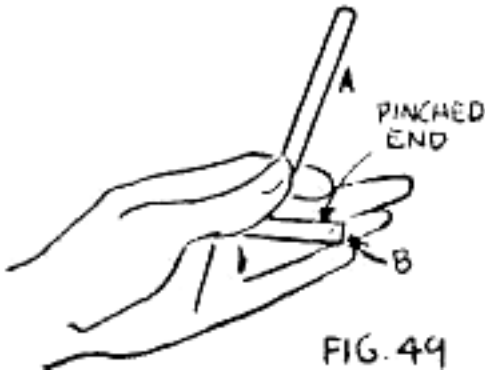
Note:

You may continue showing hands back and front by merely continuing the manipulations taught to you above.

THE MULTIPLYING CIGARETTE

EFFECT:

One cigarette is shown by performer, and suddenly another is produced from the first.



To Perform:

Pinch end of a cigarette and conceal it by grasping it in crotch of left thumb--B. Hold another cigarette exposed at tips of thumb and first finger--A.

Figure 49.

(33-8)



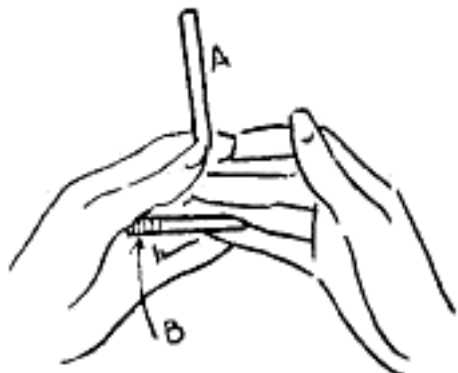
To audience it appears that you are just holding one cigarette in left hand. Back of hand is exposed.

Left side of body is toward audience.

Figure 50.



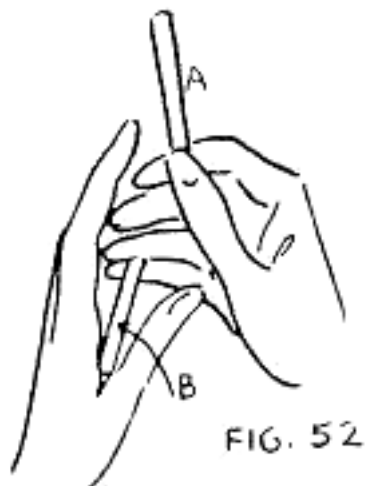
FIG. 50



Bring right hand down to left, placing tips of fingers just inside left fingers. Grasp pinched end of concealed cigarette between third and fourth fingers of right hand.

Figure 51.

FIG. 51



Start moving hands to left and turn body to left. As you do so, grasp cigarette A in right finger-tips and remove cigarette B from crotch of left thumb.

Figure 52.

FIG. 52

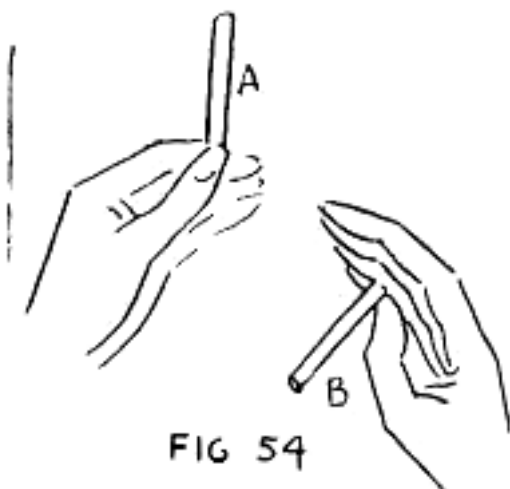


As you turn to left, palm of left hand and back of right are exposed to audience. Fingers of right hand are curled into palm sufficiently to conceal cigarette B.

Figure 53.



FIG. 53



Take cigarette A into left hand again. Raise right hand, getting right thumb under cigarette.

Figure 54.

Bring the two hands together so that cigarettes are parallel. Under cover of right hand, pivot cigarette B upward against finger-tips. Then produce the second cigarette, pretending to pull it out of the first one.

FIG. 54

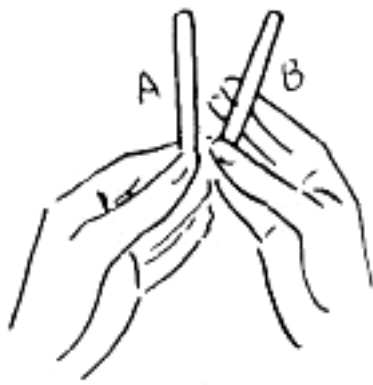


FIG 55

Show both cigarettes freely to audience as you face front.

Figure 55.

THE CHANGE-OVER PALM

EFFECT:

Both hands are shown empty, and yet a cigarette is concealed in them.

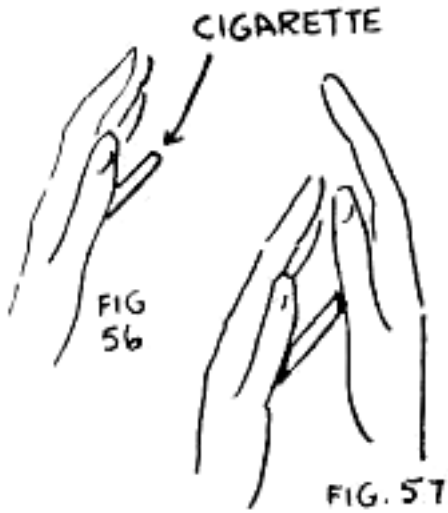


FIG 56

FIG. 57

To Perform:

Hold cigarette in crotch of left thumb. Left side of body is toward audience and back of left hand is exposed. Palm of right hand is shown freely. Bring right hand down to left and with crotch of right thumb grasp end of cigarette.

Figures 56 and 57.

(33-9)



Begin to swing hands to left as you turn body to left. As hands come directly in front of you, keep finger-tips together to conceal cigarette.

Figure 58.



Continue turning to left so that hands come into position shown in Figure 59.

Holding cigarette in right hand, show palm of left hand freely.

The Change-Over works from crotch of one thumb to crotch of the other. This may be continued from side to side several times if desired. It may be done from left to right or right to left.



A variation of the Change-Over is performed by gripping end of cigarette between first and second fingers instead of in crotch of thumb.

Figure 60.

* * * * *

THE BURNING CIGARETTE AND SILK HANDKERCHIEF

EFFECT:

After showing both hands empty, performer places a lighted cigarette into his left hand, closes his hand and suddenly reopens it. The cigarette has been transformed into a silk handkerchief.

PARAPHERNALIA:

- 1 -- A Thumb Tip.
- 2 -- A silk handkerchief, about 13 inches square.

MODUS OPERANDI (Method of Working):

To Prepare:



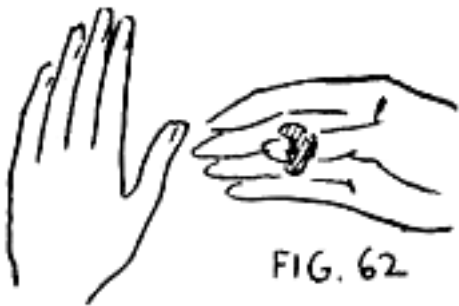
Wrap handkerchief around Thumb Tip. Tuck the free end well in so that handkerchief is secure. Do not have handkerchief too tight for it must be released easily when the time comes.

Figure 61.

Have prepared Tip in one of your right pockets.

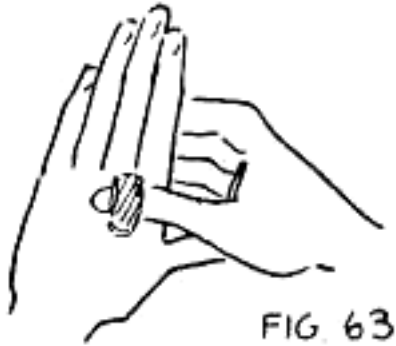
To Perform:

Secretly get Tip on right thumb.



Hold palm of left exposed to audience and back of right hand to audience. Bring your hands together.

Figure 62.



Place right fingers in front of left hand and thumb behind.

Figure 63.



Raise right fingers, still keeping thumb behind left hand. This exposes palms of both hands to audience.

Figure 64.

Bring right fingers down again, then pull right hand away from left, and show backs of both hands to audience.

As you show back of left hand, bring right hand over to it and get Thumb Tip into left palm. Close left hand around Tip and handkerchief.



Take a lighted cigarette from a spectator or one of your own, break it in half, and show it freely. Place it in closed left hand, getting it into Tip.

Figure 65.



Push right thumb into Tip. Free Tip from handkerchief and bring it out with thumb pointed directly at audience to conceal it. Show palm of right hand empty, then back of hand.



Open left hand gracefully, exposing the silk in it. With movements of left fingers open up the silk and then hold it between your hands to show it to audience.

Figure 66.

THE PHANTOM CIGARETTE

EFFECT:

Performer makes an imaginary cigarette and places it in his mouth. This is all done in pantomime. He takes a box of matches from his pocket, lights a match and brings it up to his mouth. Suddenly a real cigarette appears between his lips and he lights it with the match.

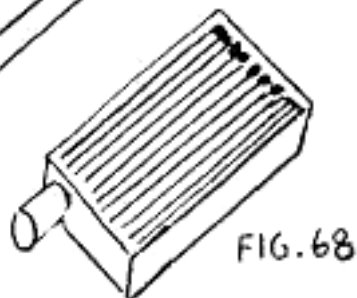
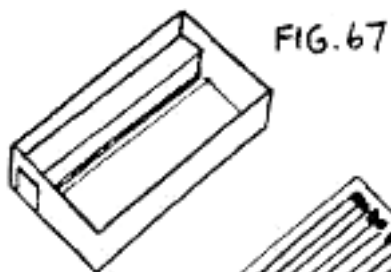
PARAPHERNALIA:

- 1 -- A cigarette.
- 2 -- A small box of matches.

MODUS OPERANDI:

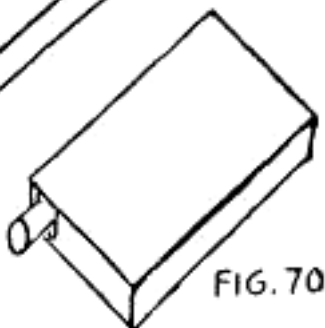
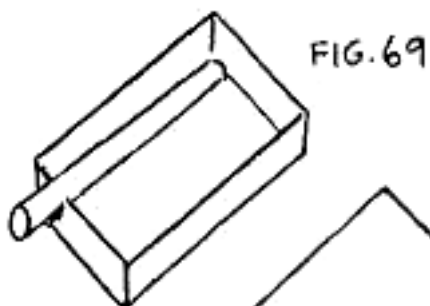
To Prepare:

The match box must be prepared to hold a cigarette.



One way is to take the drawer of the box and with a piece of playing card or thin cardboard, wall off a space to hold a cigarette. If you get this cardboard the proper length, the ends of the box will hold it in place. Cut a space through one end of the drawer into which a cigarette can be passed easily. Now fill the box with matches, and place a cigarette in the tube for it.

Figures 67 and 68.



An easier way of preparing box is to cut a hole in one end of drawer large enough for the cigarette. Place cigarette in drawer, fill box with matches to cover cigarette completely, and push drawer into cover of box.

Figures 69 and 70.

I prefer the first method. Because of the partition in the box, the matches cannot slide out of the hole when the cigarette is out of the box.

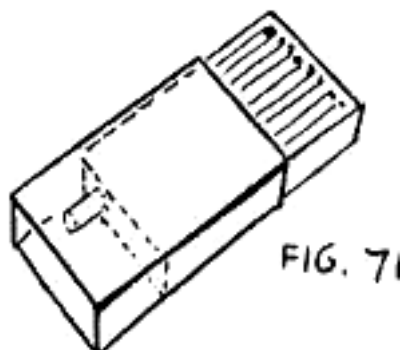
Place box in left coat pocket or have it in some other handy place.

To Perform:

The success of this experiment depends on your ability to pantomime the making of a cigarette. Study the motions carefully.

Pretend to take a package of cigarette papers from pocket, take a sheet, and replace package. Make an imaginary trough in paper. Reach into back pocket and produce an imaginary pouch of tobacco, open it, and sprinkle tobacco into paper. Pull strings of imaginary sack with your teeth to close it. Replace sack in pocket. Even up tobacco in paper. Roll cigarette. Wet end of paper and paste down. Fix ends of cigarette and place it in your mouth.

Reach into pocket with left hand and bring out box of matches. Keep prepared end of box away from audience so that cigarette will not be exposed.



Open box. This brings cigarette inside of box cover, and box can now be shown freely as you take a match.

Figure 71.

Close box and strike match on side. Holding box in left hand, bring both hands up to mouth as if to light imaginary cigarette. Under cover of hands, grasp cigarette in teeth.

Figures 72 and 73.

Pull box forward a little to release cigarette. Now light the real cigarette between your lips, remove hands, and show cigarette.



FIG.
72



FIG
73

VARIATION:

A good way to vary this effect is to ask someone for a cigarette and pretend to take one from the package he offers. Audience sees that you do not take a cigarette and are surprised when they find that you suddenly get one between your lips.

THE VANISHING CIGARETTE

EFFECT:

Performer places lighted cigarette in closed left hand. He then opens his hand and cigarette is gone.

PARAPHERNALIA:

1 -- A Cigarette Pull. This was send to you FREE with your second package of apparatus.

2 -- A cigarette - your own or a borrowed one.

MODUS OPERANDI:

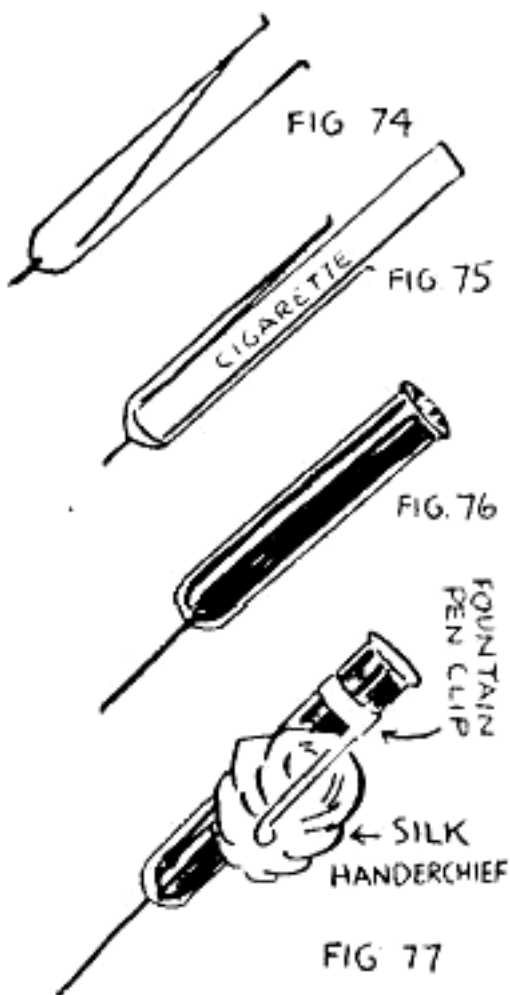
To Prepare:

The Cigarette Pull is a small metal cylinder with a spring inside. The spring keeps the cigarette tight in place when it is placed in the Pull. The Pull is attached to a length of round black elastic.

Figures 74, 75, 76.

Figure 77 shows the Pull with a fountain pen clip attached to it. Under the clip articles may be placed, such as silks, for changing lighted cigarettes into other objects. If you wish to do this, show the lighted cigarette, place it in the Pull, release the silk handkerchief from the Pull, and let Pull slide back under cover. Then show the silk.

The Cigarette Pull is adjusted to body in same manner as Handkerchief Pull. It is well to use the Handkerchief Pull on the right side and the Cigarette Pull on the left side.



Keep Cigarette Pull in place by a small ring or pin.

Figure 77 A.

To Perform:

Place cigarette in mouth and light it. Turn right side of body toward audience. Reach up with left hand and close your fingers over Pull.



Face front, bringing left hand with Pull up in front of body. Left hand and arm conceal Pull and elastic.

Figure 78.

FIG
78

(33-13)

Show lighted cigarette with right hand. Place it apparently in closed left hand with lighted end down -- really in the Pull in left hand. Release Pull and allow it to slide back under coat into original position. Open left hand gracefully and slowly and show that cigarette has vanished.

THE VANISHING PENCIL

Ed Reno has a favorite impromptu stunt in which he uses the Cigarette Pull to vanish a pencil. He takes his lead pencil from his pocket and says, "You have perhaps heard about breaking a pencil with a dollar bill. Here is a new way of doing it without a bill." While he says this, he is demonstrating by striking pencil on the table. This is merely for misdirection - to get right side of body toward audience and secure Pull in left hand. He then faces front and puts pencil down in left hand, into Pull. Holding top of pencil with right hand, he makes a movement as if to break pencil. As soon as pencil is fully concealed by hands, Pull is released and goes back into place under coat. Hands are opened and audience sees that pencil has disappeared.

THE DOLLAR BILL IN THE CIGARETTE

EFFECT:

Magician borrows a dollar bill and requests that owner remembers the number. He then takes out a box of cigarettes and has one selected. He places this one in his mouth. Folding the dollar bill he tucks it into his closed left hand. In a moment he opens his hand and the bill has vanished. He lights the cigarette and finds that it does not draw well. Magician then tears the cigarette apart and discovers the dollar bill inside of it. Bill is unfolded and returned to owner to check up on the number and make sure it is his own.

PARAPHERNALIA:

- 1 -- A package of cigarettes.
- 2 -- A dollar bill.
- 3 -- A Cigarette Pull.

SECRET AND PATTERN:

To Prepare:

You must prepare one cigarette. Carefully remove all the tobacco except about one-half to three quarters of an inch near the end. Do not injure the paper. You will have no difficulty in removing tobacco with a pair of tweezers or a toothpick, or rolling cigarette.

Figure 79.

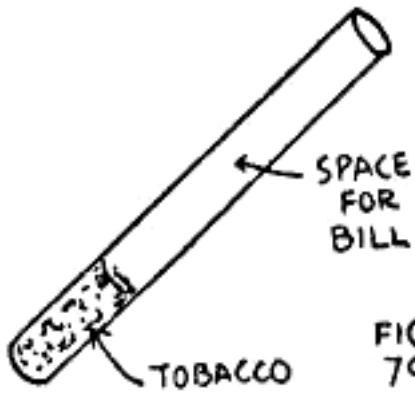


FIG 79

Take the dollar bill and copy down the last three digits of the number and the series letter after it.

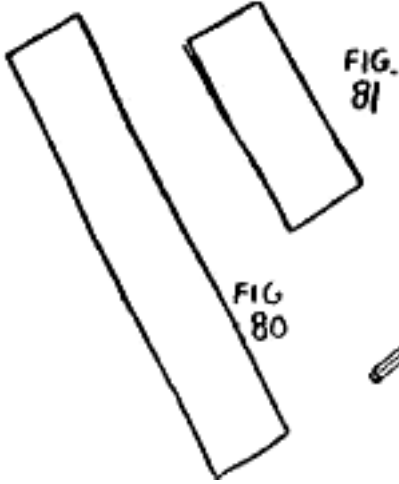


FIG. 81

FIG 80

Fold the bill in half lengthwise, then in half the other way. Finally, roll up the bill as tight as possible.

Figures 80, 81, 82.



FIG. 82

Place rolled bill in hollow space in prepared cigarette. Turn cigarette as you insert bill and you will find it easy to do. When bill is well concealed in cigarette, place a little tobacco on top of it to make cigarette look natural.

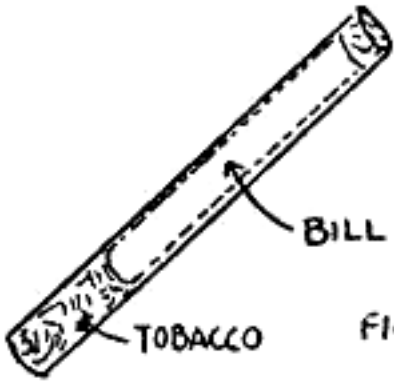


FIG. 83

Figure 83.

Take box of cigarettes. Remove all cigarettes but two. Place these two at one end of box and place prepared cigarette next to them toward inside of box.

Place box of cigarettes in pocket.

To Perform:

Come forward to audience.

"I should like to borrow a hundred-dollar bill. The gentleman sitting over there says he would, too. Or a fifty-dollar bill -- a twenty -- a ten -- a five -- or who has a dollar? Just a dollar bill. Ah, here is a gentleman who trusts me. Thank you, sir."

Take dollar bill from gentleman. Be sure that it is not too old or too new and resembles the bill you have in cigarette. Should it be too old, say:

"It might fall apart. I need a sturdy, youthful bill."

If it is too new, say:

"That is a brand new one and I might soil it. Give me one that has seen service. I want a bill with experience."

Holding bill in full sight, go back toward the stage. Suddenly stop as if a thought occurred to you and say:

"Pardon me, sir, but would you mind just copying down the number on your bill. As you are the owner of it, you would, no doubt, like to identify it again later. Just write the last three digits -- 7, 6, 4 -- and the letter A."

Assume that those were the numbers on the bill you placed in the cigarette. Whatever those numbers are, call them out

to the spectator to mark down. Audience and owner of bill believe that you are actually reading off the numbers from borrowed bill while in reality you are giving the numbers on the bill in the prepared cigarette.

Keep the dollar bill in plain sight. Bring out package of cigarettes from your pocket. Hold box so that cigarettes slide over to right side of box and hand to spectator so that prepared cigarette is nearest him. As a rule, spectator takes this cigarette when you offer the box to him.

"That's fine. You have selected a cigarette for me, sir."

Take cigarette from him and place it in your mouth.

Ask spectator to take another for himself. If he did not take the prepared cigarette for you the first time, merely let him keep the first one, and you select the prepared one for yourself.

"Have one yourself, sir, and we'll have just a little smoke between friends."

Replace cigarette box in pocket.

Go back to stage. While your back is turned, get Pull in left hand, closing your fingers over it. Hold dollar bill up in right hand all the time.

Now turn and face audience.

Spread out dollar bill, holding it between hands.

"It is said that if a person folds a dollar bill and then puts it in his pocket, when he takes it out again, he finds his money in creases."

Fold bill over and crease it down. Continue folding and rolling it a little so that it can be easily tucked into Cigarette Pull. Place bill in Pull under cover of hands and release Pull.

"However, in folding money so many times, it certainly makes it look small - in fact, so small....."

Open left hand and show bill has vanished.

"That it is quite invisible. This, of course, isn't difficult to do because most anyone can get rid of money. Now, the production of money is more difficult."

Take box of matches from pocket and light the cigarette which has been in your mouth ever since the spectator selected it from the box you offered him. Replace matches.

"I guess that's why many fellows light up a cigarette and try to imagine they are rich. But not so good with this cigarette. It doesn't seem to smoke so well."

Take cigarette from mouth and look at it.

"As we say jokingly, one to another, 'It would make a poor artist as it doesn't draw so well.'"

Break open cigarette and show bill inside.

"There seems to be a cause back of effects."

Unfold dollar bill.

"There is money in cigarettes."

Look at number on bill.

"Ah, sir, I believe it is your dollar. The number is 7, 6, 4, A. Is that correct, sir? I shall let you have the bill so that you can check up for yourself."

Return bill to owner, and have him identify it.

"It is your bill. Fine. Lucky I decided to smoke or you may never have got your bill back -- or I might say your greenback."

* * * * *

CATCHING CIGARETTES IN THE AIR

EFFECT:

Performer borrows a hat, shows it empty, and then proceeds to catch a number of cigarettes in the air and tosses them into the hat. His hands are shown empty all the time and the productions are most mysterious.

PARAPHERNALIA:

1 -- About a dozen cigarettes.

2 -- A Cigarette Clip.

MODUS OPERANDI:

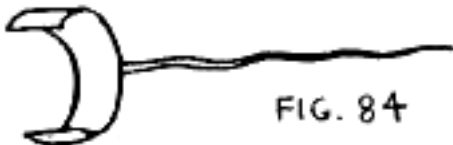


FIG. 84

To Prepare:

Clip consists of a flesh-colored piece of metal which clamps on to first phalange of second finger of right hand. To this piece of metal is attached a long pin on which cigarettes are placed.

Figures 84 and 85.



FIG. 85

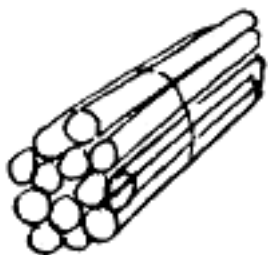


FIG 86

Place a cigarette on the Cigarette Clip. Take rest of cigarettes with the one on Clip and wrap them in a little bundle with thread or rubber band.

Figure 86.

Place bundle of cigarettes in lower right vest pocket or in special pocket inside right side of coat so that you can get it easily.



To Perform:

Borrow hat and hold it in right hand. As you go back to stage, remove bundle of cigarettes from pocket with left hand. Bring hat in front of you for a moment to get bundle under brim as shown in Figure 87.

This method of handling is similar to that used in production of silks from a hat or in loading coins for The Miser's Dream.

Turn to right and face audience. Hat is now held with left hand concealing cigarettes under brim. Show hat empty, then turn it over to show outside with nothing concealed, bringing bundle of cigarettes inside of hat. Turn hat with opening up again and let bundle fall into crown. Reach in with right hand and quickly break thread or remove rubber band from bundle.



Adjust Cigarette Clip on back of second finger of right hand as you do this. Cigarette lies along back of finger.

Figure 88.

NOTE:

Sometimes performer carries prepared cigarette on Clip in his right coat or trousers' pocket. While talking to audience, he reaches into his pocket and adjusts Clip on finger.



Remove hand from pocket or hat and be sure to keep back of it away from audience to conceal Clip with Cigarette. Turn left side to audience. Hat is in left hand, and show empty palm of right hand.

Figure 89.

FIG. 89



Now reach into air with right hand. Bend second finger quickly. This brings cigarette into position shown in Figure 90.

Other fingers are held straight, and the effect is that you reached into the air with fingers wide apart and suddenly produced a cigarette.

Pretend to throw this cigarette into hat. Your hand goes into hat, second finger straightens out to conceal cigarette. You bring hand out apparently empty. Remember the cigarette does not come off the clip and does not fall into the hat. Your middle finger simply bends to give the effect.

Reach into air again and produce another cigarette in same manner as first one. Pretend to toss this one into hat also. Continue this until eleven cigarettes have been produced and apparently thrown into hat. Audience is not aware that you are

producing the same cigarette every time. They believe you have produced eleven different ones. Productions may be varied by taking cigarettes from behind the knee, etc.

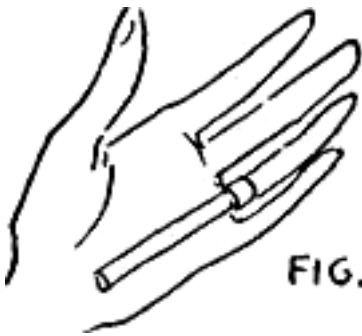
Keep palm of right hand to audience to conceal cigarette. Show cigarettes in hat to audience. Pour them out on table. Then reach into air once more with right hand and produce a twelfth cigarette. Remove it from clip with left hand as if you were merely taking it from right fingers.

Straighten right fingers immediately to conceal Clip and dispose of Clip in pocket at your earliest opportunity.

You may continue from this point with manipulations with one cigarette if you desire.

NOTE:

The Cigarette Clip is a handy piece of apparatus. It may be used to perform The Phantom Cigarette. It does away with use of prepared box of matches.



To do this, first place clip at base of third finger of left hand with cigarette extending into palm.

Figure 91.

With Clip in this position, back of hand must be held toward audience. Hand and fingers may be moved freely.

Go through pantomime of making cigarette and lighting match. Toss match box aside. As you bring hands in front of mouth, get cigarette between your teeth and draw it from Clip. Light it and show the real cigarette.

* * * * *

AN ODD CIGARETTE VANISH

EFFECT:

Performer shows a cardboard box with a number of cigarettes in it. He takes them out one at a time and places them in another cardboard box. Picking up the second box, he commands the cigarettes to vanish, and they do. Magician shows the empty box and tears it up to prove that the cigarettes are gone.

PARAPHERNALIA:

- 1 -- Two cardboard boxes, about 16 inches square.
- 2 -- A few cigarettes.
- 3 -- A Cigarette Clip.

(33-19)

MODUS OPERANDI:

To Prepare:

Place one cigarette on the Clip. Place this cigarette in one of the boxes.

Place the two boxes about two feet apart on the table. To Perform:

Have left side toward audience as you stand near the box with the cigarettes. If the table is small, you may hold this box in left hand.

Show the empty box and replace on table. Show cigarettes in other box. Reach in with right hand, pick up some of the cigarettes, and let them fall back into box. As you do this, adjust Clip on back of second finger of right hand, as in Figure 88. Show cigarette as in Figure 90.

Reach over to empty box as if to throw cigarette into it. Place hand inside of box and when it is concealed, merely straighten out second finger and bring hand out apparently empty.

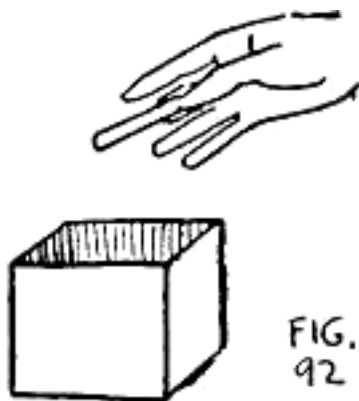


Figure 92.

Reach into first box again, pretending to take another cigarette, but in reality merely bending second finger to produce cigarette on Clip. Bring hand out showing cigarette, and go through routine again of apparently dropping cigarette in second box.

Continue this for the same number of times as there are cigarettes in the first box. Audience believes that you are taking cigarettes from the first box and putting them into the second, whereas you are really just carrying one cigarette back and forth.

After last cigarette has been apparently dropped into second box, show right hand empty and drop it to side. Under cover of your body, dispose of cigarette and Clip in your pocket.

With left hand lift second box, presumably containing cigarettes now. Turn box over to show that cigarettes have disappeared, then destroy box by tearing it apart to show that it is not a trick box.

* * * * *

CARDINI'S FLOATING CIGARETTE

This is a pretty novelty in the hands of this noted magician. It is suitable for the stage or any place where a thread will not be visible to spectators.

EFFECT:

Magician borrows a cigarette or has one of his own examined. He places it in a glass tube which has a screw cap at top and bottom. A hoop is passed over the tube to show that there is no outside connection. Suddenly on command, the cigarette rises and falls inside of the tube. Mysteriously, it stops and remains suspended when Magician desires it.

PARAPHERNALIA:

- 1 -- A cigarette.
- 2 -- A piece of fine black silk thread, 24 to 30 inches long.
- 3 -- A black pin, or needle painted black.
- 4 -- A glass toothbrush holder with screw covers at both ends. The covers are of metal with holes punched in them for ventilation. These holders may be purchased at any ten-cent store.
- 5 -- A wooden or metal hoop, about six to eight inches in diameter.

MODUS OPERANDI:

To Prepare:

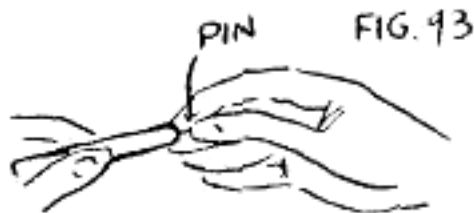
Take the piece of thread and attach the pin to one end. Run the pin through a hole in one of the metal caps of holder, going from outside to inside. Attach free end of thread to your middle vest button.

Place the threaded screw cap in lower right vest pocket and insert the pin in top of pocket where you can get at it easily.

Screw the other metal cap on bottom of glass tube.

To Perform:

Come forward and ask spectator for a cigarette. As you go back to stage, get pin from vest pocket between thumb and forefinger of right hand.



Under pretense of examining cigarette, push pin into one end of it. In this way cigarette is attached to thread.

Figures 93 and 94.



Pick up glass tube with left hand and show it to audience. Transfer cigarette to left hand also. Reach into pocket and get screw cap with right hand. Now drop cigarette in tube and screw on cap.

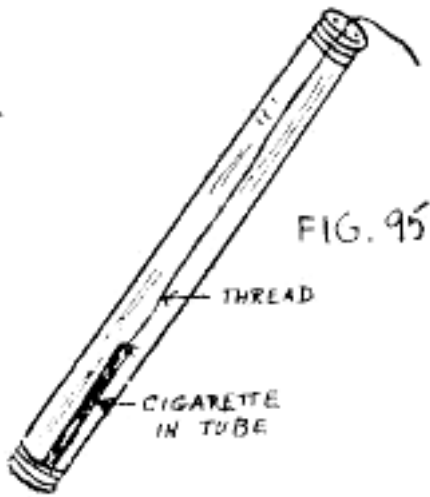


Figure 95.

Allow cigarette to fall from end to end of tube to show audience that it is not attached inside. Pick up hoop from table and pass it over threaded tube in same manner as you pass hoop over threaded deck in a glass. (See Lesson 18, Figures 29 to 38).

Place hoop aside.

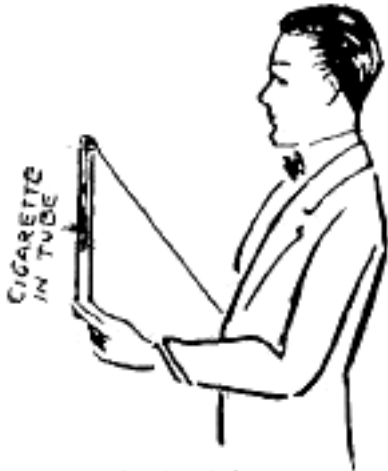


FIG. 96

Now hold tube at bottom in left hand. By moving tube toward or away from body, thread is loosened or tightened, and cigarette rises or falls accordingly. The movement need be only slight to get the effect, and as the movement is horizontal to and from body, it is not noticeable at all to audience.

Figure 96.

Make cigarette rise to top of tube, fall to bottom, and remain suspended at different places. Make it rise rapidly and then fall slowly, etc., just to make it interesting.

To finish the trick, have cigarette come to top of tube. Grasp thread with thumb and finger-tips of right hand and pull pin out. Insert pin in your vest as you misdirect attention of audience to the tube. Tube and cigarette may now be passed out for examination, or tube opened and cigarette thrown out to audience.

* * * * *

TO PRODUCE LIGHTED CIGARETTE FROM BOX

EFFECT:

Performer takes cigarette box from his pocket, opens it, and produces a lighted cigarette from it. He places cigarette in his mouth and smokes it for a few minutes.

MODUS OPERANDI:

To Prepare:

Take a cardboard cigarette box and cut an air hole in each side of it. On the bottom fix some wire, bending it so that it will raise burning cigarette from bottom of box and hold it midway between bottom and cover. Wires can be sewed to bottom of box and attached to other pieces of cardboard to fit into box. If extra pieces are used, sew them to bottom of box.

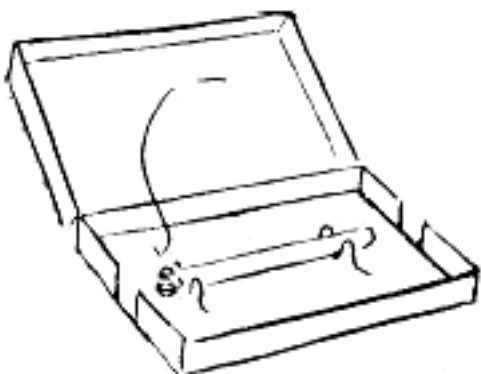


FIG. 97

Figure 97.

To Perform:

This makes a nice conclusion to The Vanishing Cigarette. After cigarette has disappeared, reach into pocket, take out box, produce lighted cigarette and smoke it.

NOTE:

Light the cigarette in the box just before using so that it will not burn down too much.

A handwritten signature in cursive script that reads "Harlan Tarbell". The signature is fluid and elegant, with a large, sweeping flourish at the end.

TARBELL SYSTEM, INCORPORATED. Chicago.

* * * * *

LESSON 34

Your next lesson gives you some fascinating impromptu card tricks. You can perform them with an unprepared deck and thus can depend on a borrowed deck. The effects are very mysterious and give you an excellent repertoire of amazingly mystifying yet wholly impromptu card effects.

(33-23)

TWELVE IMPROMPTU EFFECTS WITH CARDS

This series of impromptu card effects will be a very valuable addition to your Magic repertoire. The experiments are all easy to perform but they are most mystifying and make the performer appear to have great magical powers. Every one of them can be done with a borrowed deck, and thus can be used for emergency work. These effects provide excellent entertainment.

1 - A BAFFLING DISCOVERY

EFFECT:

Performer places five cards in a row on the table, turns his back and asks a spectator to look at one of the cards, remember it, and replace it in its original position. Magician then gathers up the five cards, and showing his trousers' pocket to be empty, places the cards in it. He states that he will remove all the cards but the selected one from his pocket. He does so, and finally removes the fifth card and shows it to be the selected one.

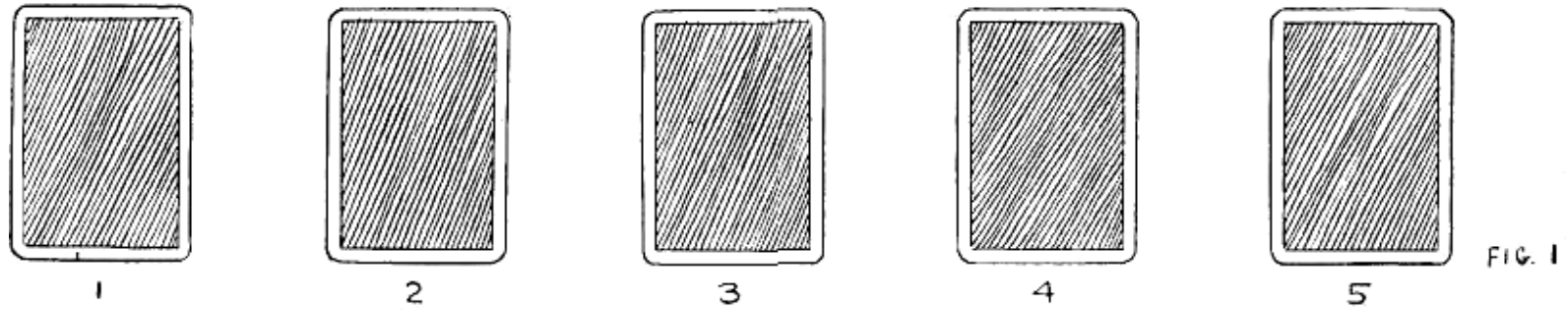
SECRET AND PATTEN:

Take deck of cards and hold it with backs of cards up. Secretly palm off four cards with right hand and place them in right trousers' pocket, backs outward, as you reach in for a handkerchief.

Have spectator shuffle deck thoroughly.

Count off FIVE cards, one at a time, and place them in a row on table.

Figure 1.



Place rest of deck aside.

"This is really an experiment in psychology to determine certain mental reactions and harmony of thought. I have placed five cards in a row on the table. Beginning with the left, we will number them one - two - three - four - five."

Point to cards as you call them out. Then say to spectator:

"When I turn my back to you, sir, will you please look at one of the cards and remember it. Replace it in its original position so that I cannot tell which one you selected. If you care to, move the other cards a little also. Remember your card and its number in the row."

Permit spectator to select card and replace it.

"Are you ready? All right."

Turn and face audience again. Pick up the cards, starting with number 1. Place it on top of number 2, then both cards on number 3, and so on.

Place cards in left hand, and with right hand show right trousers' pocket empty. This is easily done by pushing the four concealed cards into upper corner, as you have been taught to do. Replace pocket. Take cards from left hand and place them in right trousers' pocket also, BEHIND the four concealed cards. Backs of all cards must be outward.

To spectator who selected card:

"Will you please think of your card for a moment. That's enough. I believe I have the right impression."

Reach into right trousers' pocket with right hand.

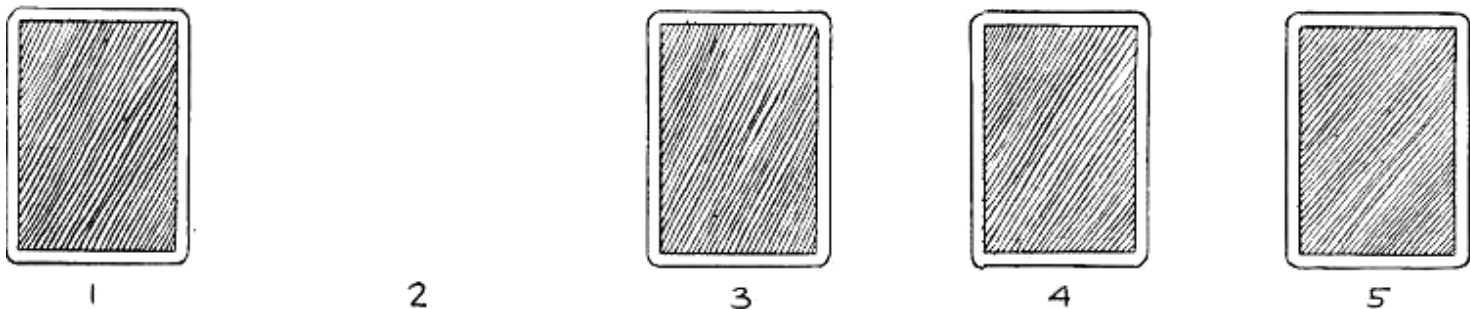
"I shall separate the card you selected from the others and remove the four cards which you did not select. The selected card will remain in my pocket."

Remove the four concealed cards (the outermost cards) - one at a time - and place them in left hand with backs to audience. These are the four cards that have been in your pocket from the very first.

"You did not select any one of these so I shall replace them on the table. First, however, what was the number of the card you selected? The second card, you say."

Place the cards in a row again on the table, starting with number 1 and leaving a space for number 2 (or whatever number the selected card happens to be.)

Figure 2.



Reach into pocket with right hand. Quickly push out of the way the outer card, which was the first card in the row you placed on the table at the beginning. (If some other card was selected, push forward the proper number of cards to enable you to get at the selected card.)

Lift out the second or selected card and remove it from pocket, back toward audience.

"I reserved a space on the table for the card which I left in my pocket. I believe this is your card."

Turn face of card toward audience and then place it in second position on table.

"The Seven of Clubs (or whatever it may be) is the card you selected."

NOTE:

Regardless of which number spectator selects from the five cards, you will have no difficulty in producing the selected card. When spectator calls number of card, merely push forward the cards not wanted and bring out the selected card. ALL of the original five cards from the table are in your pocket, though spectators think you removed four of them when you brought out the four concealed cards.

Learn to remove any one of the five cards in your pocket without fumbling. You must do it as though there were really only one card in your pocket. The best way to pick out the selected card is to push the top of each card forward with your thumb and hold it between your first and second fingers until you reach the selected card. The first and fifth cards are easy to remove. If number four is called, you can reach it quickly by starting from the rear.

When you finish the experiment, four cards remain in your pocket so that you may repeat the effect once or twice more. Do not be in a hurry to get these four cards out of your pocket when you are through. When you are ready to remove them, place the whole pack in your pocket and then remove it with the four cards. Or, you may perform the Cards Up The Sleeve. As you already have four cards in your pocket, begin by False Counting 8 cards as 12, and then proceed.

* * *

2 - ROYAL CARD DISCOVERY

EFFECT:

A deck of cards is shuffled. Performer turns up the top card and shows it (suppose it is a three spot). He places it on the table, back up, and counts other cards on top of it, starting from three - thus: three-four-five-six-seven-eight-nine-ten. He stops at ten and then turns over the next card. Say it is a five spot. He places this down and starts another pile of cards, counting from five to ten. Then he turns over the next card and starts counting another pile from whatever number that card happens to be. Court cards count for ten. If a court card or ten spot are turned up, they are placed by themselves as they already count ten. When the whole deck has been laid out in piles in this manner, performer takes all piles of less than four cards and places them to-

(34-3)



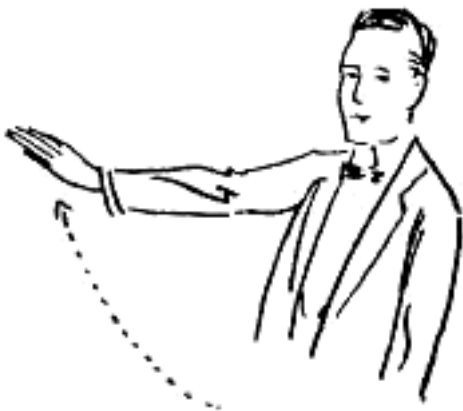
Cigarette can then be easily grasped in crotch of right thumb.

Figure 17.



Drop right hand to side. Keep back of hand to audience.

Figure 18.



Then raise right hand, still keeping back of it to audience.

Figure 19 shows hand as audience sees it.

FIG. 19



Figure 20 shows palm of hand away from audience with concealed cigarette.

FIG. 20



Now you are to turn hand over quickly to show palm empty to audience. As you turn hand, force end of cigarette between first and second fingers.

Figure 21.

FIG. 21

THUMB CONCEALS CIGARETTE



Press tip of right thumb against fingers and other end of cigarette to conceal it. Palm may now be shown empty. Turning of hand must be done quickly and naturally as if you actually had nothing in your hand.

Figure 22.

FIG. 22



Turn your hand to show back again, and as you do so, pull cigarette back between first and second fingers to palm of hand again.

Figure 23.

FIG. 23

Do this back and front movement two or three times. Then as you show palm for the last time, get cigarette to fingertips by pivoting lower end upward, and produce cigarette.

This may be performed with a burning cigarette. Be sure to open fingers wide enough when you pass the burning end between your fingers so that you will not burn

yourself.

THE THROWING VANISH

EFFECT:

A lighted cigarette is thrown into left hand. Hand is closed and then opened, and cigarette is found to have disappeared.

(34-4)

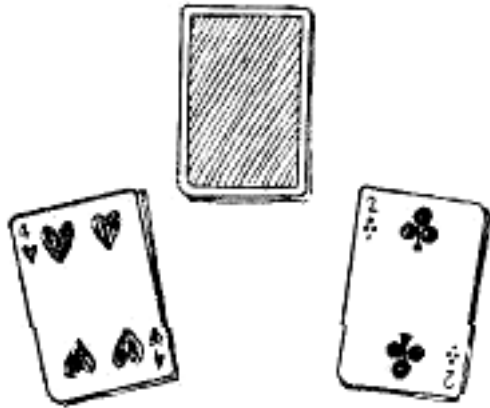


FIG 3

When two of the three packets are turned over, notice the cards that were on the bottom of each. Assume that one is a four spot and the other a two spot.

Figure 3.

If you have removed 19 cards from packet in left hand, fan the remaining cards to the right. If you have merely separated these 19 cards, fan only those cards under your little finger, disregarding the 19 cards. Add the numbers on the two exposed cards of the selected packets -- in this case, four plus two, making six. Count off six cards mentally from those fanned in your left hand.

The number of remaining cards will tell you the number of the bottom card of the selected packet. If five cards remain, then that concealed card is a five spot, and so on.

"We have one pile left. None of us know what the bottom card is on that packet. That is where Magic comes to the rescue. A little spirit of Magic jumps on my shoulder and whispers in my left ear that the bottom card on the selected pile is A FIVE SPOT!"

Turn over the selected packet and show the card to be a five spot.

NOTE:

This effect works on a mathematical principle and will never fail you if you do each move properly.

* * *

3 - BIRDS OF A FEATHER

EFFECT:

A deck of cards is thoroughly shuffled. Spectator then cuts deck into two portions, gives one to the performer and retains one himself. Spectator is then asked to remove a card from those he holds and place it on the table. Performer also removes a card from his packet, shows it, and places it on the table. Assume that it is the Ten of Diamonds. Magician then places spectator's packet on top of his and shuffles them together. Spectator then cuts deck in half again and places his selected card - say, the Jack of Spades - on one half of the deck. About half of the remaining packet of cards is placed on top of his card and then performer places his selected card on top of that. The rest of the deck is placed on his card. Though the two cards are widely separated in the deck, the Magician causes them to come together and in a moment shows them to be side by side.

(34-5)

SECRET AND PATTERN:

Have deck shuffled by spectator, then say to him: "Cut the deck, please, and keep the packet that you lift up."

You pick up the remaining packet and place it in your left hand, backs of cards up. Fan cards a little to the right and place little finger of left hand under top two cards. Square cards again.

"Now, sir, remove any one of the cards in your packet. look at it, and place it on the table. I, too, shall take a card at random."

Do the Double Card Lift with the upper two cards of your packet and show the outer or second card. Suppose this card is the Ten of Diamonds and the King of Hearts is the top card concealed back of it.

Replace the two cards on your packet and slide the top card a little to the right with your thumb.

"My card is the Ten of Diamonds. I shall place it on the table also."

Place your card, really the King of Diamonds, on the table, back up. Audience believes this card to be the Ten of Diamonds, but the Ten is on top of your packet.

"Now place your packet on top of mine."

Have spectator place his cards on top of yours. Keep the two packets separated by your left little finger, in readiness for the pass.

Riffle shuffle the cards once, being careful to keep the Ten of Diamonds as the top card. Then turn your left side toward the audience, lift up the back packet and shuffle it in front of the other as you were taught to do in the Simplified Pass. The Ten of Diamonds is brought to the top of the deck in this matter.

Now place deck on table. Ask spectator to cut cards again and place the packet he lifts up on the table.

"Please cut the cards again, sir, and place the portion you lift up on the table. Now place your selected card on top of the part you just cut from the deck. By the way, what is your card? The Jack of Spades?"

Spectator places his card on the packet. Unknown to himself and the audience, this brings his card on top of your selected card, the Ten of Diamonds.

"On the Jack of Spades, we shall place a few other cards. Lift off a few cards from those I hold in my hand and place them on top of your card. Now, I shall place my card, the Ten of Diamonds on all these."

Take your card from the table and place it on the packet on the table. Then put rest of deck on top of your card. Square up the deck.

"I have completed the! deck by placing the rest of the cards on top of my Ten of Diamonds. Note carefully that your selected card and my selected card are separated by a number of cards. Your card is the Jack of Spades and mine is the Ten of Diamonds. Strange as it may seem, certain cards in the deck are like the birds of a feather that flock together. It is impossible to keep them apart. Your card and my card often act that way. Will you cut the cards again, sir?"

Have spectator cut the cards and place bottom pile on top.

"Cut them once more."

Have him repeat the cutting.

"Now, look through the deck and you will find that your card, the Jack of Spades, and my card, the Ten of Diamonds, have come together somewhere in the deck."

Spectator runs through cards and finds both of the selected cards together.

NOTE:

This effect rests on the law of probability. You count on the chance that the two selected cards will not be separated in the cutting. They rarely are, but if it happens that they are, merely pass it off with some appropriate remark and repeat the experiment.

* * *

4 - THE THOUGHTFUL JOKER

EFFECT:

Performer removes the joker from the deck and places it on the table. He then has the cards divided into two even heaps. A spectator is asked to remove any card from one heap, remember it, and place it on the other heap. A second spectator is asked to remove a card from the second heap, remember it, and place it on the first heap. The two packets of cards are then placed together and cut several times by a spectator. Magician picks up the Joker and says that it catches mental impressions from the audience. He then takes the deck of cards and tells the spectators who selected cards to watch as he fans the cards and to name to themselves their cards as they appear in the fan. Performer fans the cards, a few at a time, until the whole deck has been fanned. He now picks up the Joker again and names the two selected cards, supposedly getting the impressions from the Joker.

(34-7)

Deck is shuffled. Look through cards quickly to find the Joker, and as you do so, notice the two "Top" cards. Let us say they are the Eight of Spades and the Ten of Clubs. These are to be the KEY cards. Remember them.

Remove Joker from deck and place on table, face up.

"The Joker is often removed from the deck because he is more or less of a nuisance, but, in reality, the Joker is one of the wisest of cards. The Fool of the Court in olden days was many times the wisest man, and so it is with the Joker. He is very sensitive to impressions."

Riffle shuffle the deck, leaving the two Key cards on top of the deck.

"First, let us divide the deck into about equal portions."

Lay down the top card on the table, then about a foot away, place the second Key card. Now deal rest of cards, one at a time, one each of the Key cards so as to make two piles. After you have done this for a while, give rest of cards to spectator and let him continue doing it.

"Just place the cards on both piles several at a time to hurry matters. Just so we have two piles of cards when you have finished. All right, that's fine. Now, reach into the pile here on the left and remove a card. Do not let me see it, but look at it yourself and remember it. Then place that card on the pile at the right."

When spectator has placed his selected card on top of right pile, turn to another spectator.

"Will you, sir, please take a card from the right pile, remember it, and place it on top of the left pile?"

Second spectator removes card, looks at it, and places it on the left pile. Then ask him to place the two piles together.

"Place one pile on top of the other, square them up, and then cut the deck a couple of times."

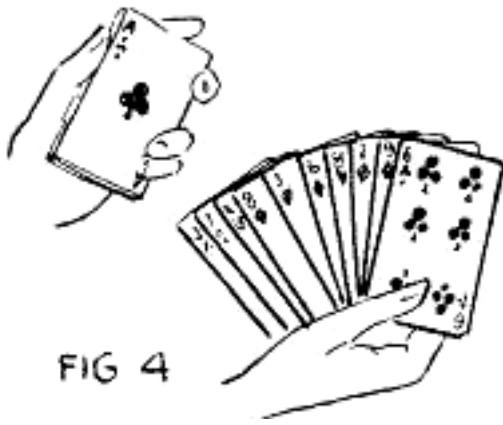
Cards are squared up and cut twice.

Now pick up the Joker.

"The Joker, as I said, has a peculiar way of catching mental impressions, and I shall depend on him to catch your impressions as they flash by."

Replace Joker on table.

"I shall fan a few cards from the deck....."



Remove seven or eight cards from the deck and fan them, faces toward spectators who selected cards.

Figure 4.

"And as I show the cards, look at them and see whether your cards are among them. When each of you gentlemen sees his card, make a strong mental impression of it by saying the name of it to yourself. Don't say anything aloud, only think it."

As you fan the cards, a few at a time, look for your Key cards -- the Eight of Spades and the Ten of Clubs, in this case. If the first card on the "Bottom" of the deck happens to be a Key card, then the "Top" card at the other end of the deck is a selected card. The other selected card will be IN FRONT of the second Key card. If the first card is not a Key card, then look through the rest of the deck as you fan the group of cards, watching for the Key cards. The card in front of each Key card is a selected card.

NOTE:

This is the reason why the selected cards appear in front of the Key cards: A Key card is at the bottom and a selected card is at the top of each pile of cards. When the two piles are put together, the Key card on the bottom of one pile comes on top of the selected card at the top of the other pile. Then when the deck is cut, the Key card on the bottom of the second pile comes on top of the selected card at the top of the whole deck.

After you have made a mental note of what the selected cards are and have fanned the whole deck through and placed each group on the table, pick up the Joker.

"Each of you gentlemen made a mental impression of your respective cards, did you not? I gaze at the Joker, and he! says that he gets an impression that your card, sir, is a red one -- hearts -- the Nine of Hearts. And you, sir, thought of a spade -- the Ace of Spades. Those were the two selected cards. Is that right? Correct! The Joker seldom fails."

* * *

5 - CARD APPEARANCE AT SELECTED NUMBER

EFFECT:

Spectator selects a card and remembers it. Card is replaced in deck and thoroughly shuffled into it. Deck is then placed on the floor or on a table. Another spectator is asked to name any number between five and ten. Assume that seven is chosen. Spectator counts the cards from the top of the deck, and when the seventh card is turned over, it is found to be the selected card.

SECRET AND PATTERN:

Force a card on a spectator, say the Nine of Hearts. You learned how to FORCE a card in an earlier lesson.

"Remember the card please, and if you care to, show it to a few of your neighbors. Take the pack in your own hands, place your card in it, and shuffle the cards well."

Give deck to spectator, and when he has replaced selected card and shuffled deck, take it from him again.

"To convince you further that your card is well shuffled and lost in the deck, let me run the cards through hurriedly before you."

Fan the cards and run over them quickly. As you do so, notice the Nine of Hearts. Starting with the card behind it, count SIX cards and place second and third fingers of right hand behind the SIXTH card to keep track of it. Do not hesitate while doing this, so that audience will not suspect anything. Continue running through the whole deck.

Now separate deck at a point where you have SIXTH card and place the packet in right hand behind packet in left. This brings the SIXTH card on "Top" of the deck.

You may now riffle shuffle the deck, being careful not to disturb the top seven cards of the deck.

Place deck on table or floor.

"Will you, sir, please select the first number that comes into your mind BETWEEN five and ten."

Accent the word - between - and in most cases, the spectator will say - seven.

"What is your number, please? SEVEN? I shall then cause the selected card to appear at Number Seven in the deck. Count the cards off one at a time from the top of the deck."

Let spectator count off six cards, and then stop him.

"Just a minute, before you count farther."

Turn to spectator who selected card and ask him again what his selected card was. Repeat it with emphasis - THE NINE OF HEARTS.

Then have second spectator turn over the seventh card and show it to audience.

"The seventh card is the NINE OF HEARTS. Correct, sir!"

NOTE:

If spectator chooses some number other than seven, you must not be disconcerted. Be prepared for such an emergency.

If he says five or ten, tell him you want a number BETWEEN five and ten. If he chooses number six, have second spectator count down six cards and then tell audience that you will cause the selected card to appear next to the sixth card. If number eight is called, slip one card from the bottom to the top of the pack or use this ruse: Show the bottom card and say, "That isn't your card, is it? All right, then I shall cause your card to appear the eighth card from the top of the deck." Place this card on the deck and have spectator count down eight cards. If spectator chooses number nine, work it this way: Fan the deck slightly, faces of cards up, and get left little finger under the "bottom" two cards. Square up the deck. Grasp the two cards in your right hand and show as ONE. Then proceed as you would if number eight were called. If you desire, you may permit spectator to choose number ten and work it by showing THREE cards from "bottom" of deck as ONE, then placing them on top of deck and having spectator count down ten cards.

SUGGESTION:

The above effect may be performed without Forcing a card Cut the pack in readiness for the Pass. Have selected card placed on lower packet. Spread bottom of upper packet a little so that you can count off six cards from the bottom quickly. Let these six cards fall on selected card and insert left little finger over them as you square up the deck. Now perform the SIMPLIFIED PASS by shuffling the top packet in front of the bottom one. This leaves the selected card SEVENTH from the top of the deck.

* * *

6 - THE CHANGE-ABOUT CARD

EFFECT:

Spectator selects a card and returns it to the deck, which is then thoroughly shuffled. Performer says that he will cause the selected card to jump to the top of the deck. He then shows the top card of the deck and it is NOT the selected one, so he places it on the table. Twice again he fails to make the selected card come to the top, and each time he places the card on the table. A spectator is then asked to choose one of the three cards and the chosen card mysteriously changes into the selected one.

SECRET AND PATTERN:

Have spectator draw a card from the deck, remember it, and then return it to the deck where you cut it. Place your left little finger over the selected card and do the SIMPLIFIED PASS, bringing the card to the top.

Hold deck in left hand, backs of cards up. Fan deck a little to the right so that you can insert left little finger under the top three cards. Square deck. Say to spectator who selected card:

(34-11)

"Before going any farther, let me ask you -- is the top card your card?"

Pick up the three top cards as one with your right hand and show the third card as the top one.

"It is not."

Replace the three cards on the deck and square up. Fan cards again and get little finger of left hand under top two cards. Square deck.

"In that case, it might prove an interesting experiment to cause the card you selected to appear instantaneously on top of the deck."

Lift the two cards as one and show second card.

"This, then, is your card, is it not?"

Spectator denies it, of course. Release cards on deck and square up, immediately slipping top card halfway off the deck into right hand.

"That is peculiar. I seldom make a mistake like that. I will just lay this card down on the table and try again."

Cut deck and riffle the cards once.

Place top card on table.

"We should be successful this time."

Lift up top card again and show.

"Is this it? No? That is, indeed, strange!"

Place card on table a few inches to left of first card placed on table.

"The third time should surely be successful."

Riffle cards once again and lift off top card.

"No? This isn't your card either? We'll toss that one here."

Place third card at right side of first card a few inches away.



FIG. 5

Figure 5 shows arrangement of cards with selected card in the middle.

"Three times I have failed to discover your card. Please touch one of the three cards on the table now."

If you lay the cards so that the middle one is nearest the spectator, he will usually touch that one. If he does, then say:

"Just keep your hand firmly upon it."

Turn the other two cards face up.

"I have given you free choice of any of the three cards which you say are not yours. Therefore, your card is some place in the deck. By the way, what was your card? The Queen of Diamonds?"

Riffle deck with left thumb.

"Did you hear that noise? When I ran my thumb over the cards, I caused the card under your hand to jump suddenly up into the deck and change places with the selected card. which is now under your hand. Lift up that card. Is it your selected card, sir? It is!"

Have spectator show card.

NOTE:

In case spectator selects one of the two end cards instead of the middle one, then push that card aside, turn it over, and say that you will eliminate that one. Ask spectator to choose one of the two remaining cards. If he takes the selected card, finish the experiment as before. If not, merely discard the other card also and proceed with experiment.

* * *

7 - FIND THE BURGLAR

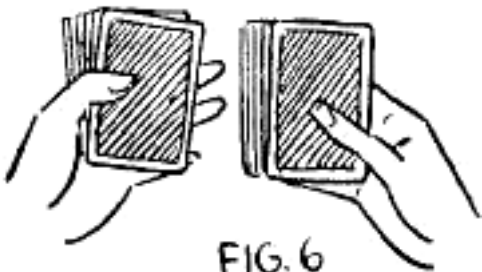
This experiment is adapted from Jack Merlin's popular effect.

EFFECT:

Two kings are moved from the deck. A card is chosen and returned to the deck, and then the deck is shuffled. First one king is placed in the deck and next to it the other one is placed, both extending about half way. Performer states that the kings are very clever detectives and a burglar could not escape them. Supposing that the selected card is a burglar, it will not take long for the kings to find him. Magician moves kings up and down. Suddenly he pulls them out of the deck and shows the selected card to be between them.

SECRET AND PATTERN:

Remove two kings from the deck and place them on the table. Fan rest of cards and have one selected.



Square up deck and fan it again, separating deck about in half. Hold one portion in each hand.

Figure 6.

(34-13)

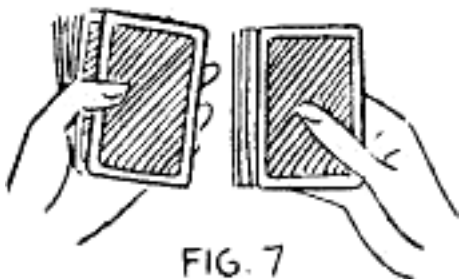


FIG. 7

Have selected card placed on top of left-hand portion. With left thumb push it over to right about half an inch.

Figure 7.



FIG. 8

Place packet from right hand on left-hand portion, and as you do so, bend the lower right-hand corner of selected card with third finger of right hand.

Figure 8.



FIG. 9

Figure 9 shows view underneath the cards. Selected card should project enough so that you can bend the corner easily.

Square up the cards and pass to a spectator to shuffle overhand.

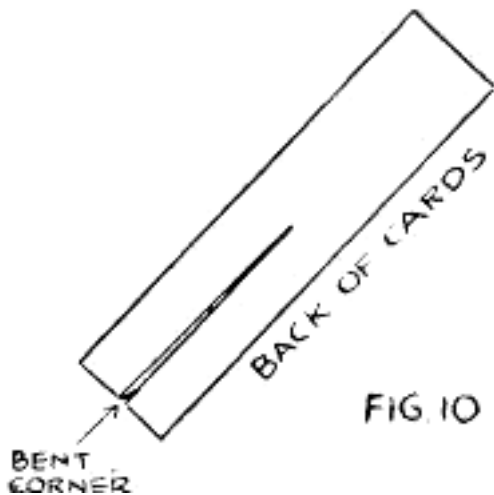


FIG. 10

Turn cards up now so that one can see bent corner at top edge. Audience, of course, must not see it.

Figure 10.



FIG. 11

Pick up one of the kings from the table and insert it into the deck in front of the selected card. You give the impression that you are inserting it at random anywhere in the deck. Insert king about half way.

Figure 11.



FIG. 12

Pick up the other king and insert it in similar manner BEHIND the selected card. The result is the selected card is between the two kings.

Figure 12.

"Few people realize that the kings in a deck are really wonderful detectives. Very few things escape them. Should a burglar get into the kingdom, he would have little chance against the wit of these two kings. For instance, let us say that the card the gentlemen selected here is a burglar and that he has been shuffled somewhere among the many other inhabitants of the deck. Though you or I might have difficulty in finding him, it is but a moment's work for the kings

to locate him."

(34-14)

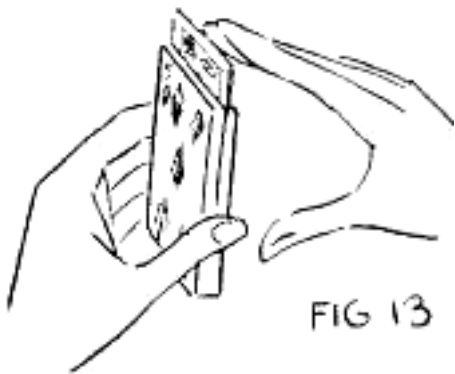


FIG 13

Hold the deck at the sides in your left hand. Tap the kings a little, pushing them downward about an inch. Pull them up again and repeat until the selected card has come up even with the kings. Each time you raise and lower the kings, the middle card automatically comes upward.

Figure 13.



FIG 14

Pull kings from deck and fan them, showing the selected card to be between them.

Figure 14.

"Was this your card, sir? The Ten of Diamonds? There it is right between the kings."

* * *

8 - THOUGHT LOCATION

EFFECT:

Spectator is asked to shuffle deck of cards, then to count down any number he desires and remember the card at that number. Performer's back is turned while spectator does this. Magician then takes pack and says he will locate the card and place it in his pocket. He removes a card from deck and places it in his right trousers pocket. Cards are then counted down to spectator's number in the deck and selected card is found to have vanished. Performer then removes selected card from his pocket.

SECRET AND PATTERN:

Give deck to spectator to shuffle. Have him hold deck with back of cards up.

"Now, sir, count down any number of cards you like and remember the card at that number. For instance, if you counted down eight cards, look at the eighth card. If it should happen to be the Nine of Spades, say to yourself, 'The eighth card is the Nine of Spades.' Do not disturb the order of the cards as you have already shuffled the deck. Remember your card and number so that we can locate the card readily later on."

Turn your back toward spectator while he counts cards and remembers one at selected number.

"After you have noted card at selected number, square up the cards evenly."

When he has done this, turn and face spectator and take deck in your own hands.

"Because of the fact that you have chosen your own number, looked at the card at that number, and squared up the deck, it would seem almost impossible for me to locate your card instantly. Yet that is just what I am going to do. I am going to remove your card from the deck."

Reach into deck and quickly remove a card about from the middle of it. Do it in a hurry so that spectator cannot see just where the card came from in the deck.

"I shall place the card in my pocket."

Keep back of card to audience and place it in your right trousers pocket. Audience believes this to be selected card.

When hand is in pocket, PALM the card and remove right hand with card in it. Place right hand on top of deck in a casual manner, leaving the card there. Whatever number selected card happens to be, this card adds one more number to it.

"Naturally, you are a bit suspicious as to whether the card I placed in my pocket is really your card. First of all, let me ask you what the number of your card is."

Assume that spectator says his card is twelfth from the top.

"The twelfth card from the top. Let us count down twelve cards."

Count off twelve cards, one at a time, into spectator's hand.

"Please look to see whether the twelfth card is yours."

The moment his attention is MISDIRECTED to see what the twelfth card is, PALM off the thirteenth card in your right hand and place it in your right trousers pocket. This is the selected card.

"The twelfth is NOT your card. you say. Well, perhaps, the one I placed in my pocket is your card."

Remove card from pocket with back of it to audience.

"What was your card, may I ask?"

Spectator names card.

"The Nine of Spades. I thought so."

Turn card over and show to audience.

* * *

(34-16)

EFFECT:

Performer asks spectator to think of any number between one and ten, then to count down from the top of the deck and note the card at that number. Performer then takes deck and places it behind his back for a moment. He removes a card from the deck and places it in his pocket. Spectator then counts down to his number again and finds his card gone. Magician then removes it from his pocket.

SECRET AND PATTERN:

Have spectator shuffle cards well.

"You have thoroughly shuffled the cards, making it impossible for either of us to know the location of the cards. Hold the deck with backs of cards up. I am going to try to perform an experiment in thought reading with cards. First, think of any number between one! and ten. Have you done that? Now, while my back is turned toward you, count down that number of cards from the top of the deck and note the card at your number. Do not disturb the order of the cards after that as we must keep in mind the location of your card from the top of the deck. After you have done this, square up the deck and give it to me."

Have your back turned while he does this, then turn and face spectator and take the deck.

"As you perhaps know, the fingers and brain are very close-ly connected in impressions -- so much so, that by placing the cards behind my back, I can sense the location of your card."

Place cards behind your back and quickly count off ten cards into your right hand. Square these ten cards up and hold them as ONE card. Show them for a moment, backs of cards to the audience. Then place them in right trousers pocket.

"That, I believe, is your card. But, let us check up first. Take the pack in your own hands. What was the number of your card? SEVEN (or whatever it happens to be). Count down seven cards and see whether the seventh card is your card."

As spectator counts the cards and audience watches him, place your right hand in your right trousers pocket and locate the SEVENTH card. You have ten cards in your pocket so regardless of what number the spectator chose, you can readily locate his card.

Remove the selected card from your pocket with back to audience.

"You say the seventh card is NOT your card. What was the card?"

Assume that the spectator names the Jack of Hearts.

"What a strange coincidence."

Turn card to audience and show it to be the selected one.

* * *

10 - THE MYSTIC CARD CLOCK DIAL

This is similar in principle to the effect just described, but has a slightly different effect.

EFFECT:

Twelve cards are placed on the table, backs up, to represent the numbers on a clock dial. A spectator is asked to think of any hour on the dial, and while performer turns away, to look at the card at that hour. Magician then gathers up the twelve cards and places them on the deck. He holds deck behind his back, removes a card, and places it in his pocket. He asks spectator to name the hour selected. He then places eleven cards in dial form on table again, leaving a space at the chosen hour. He removes the card he just placed in his pocket and shows it to be the selected card.

SECRET AND PATTERN:

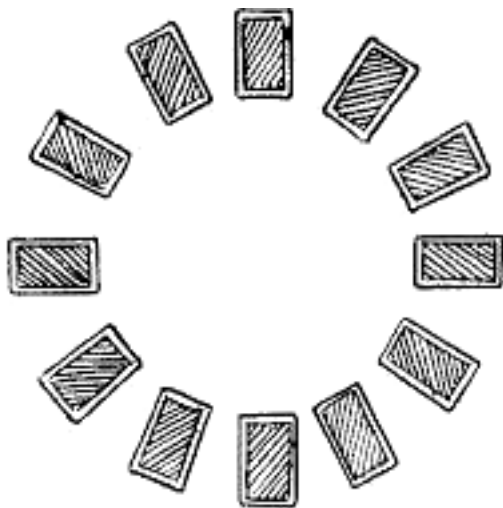


FIG. 15

Have deck well shuffled by spectator. Place cards on table in a circle to form the numbers of a clock dial. Count them as you place them down, starting with One o'clock.

Figure 15.

"This is what is known as the magic clock dial and was a popular means for communicating time from one magician to another in centuries gone by. For instance, if a magician wanted to make a date with another magician who lived at a distance, he would merely select the hour, turn over the card at that hour for a moment, and then replace it again. Suppose he wanted to meet his friend at four o'clock. He would turn over the card at number four."

Turn over fourth card and show it. Then turn back of card up again.

"Then he would turn the card over again. Instantly, on a similarly arranged clock dial in his friend's home, a duplicate card would turn over. Rather peculiar, I assure you. However, seeing is believing. While my back is turned, please choose any hour, turn over the card at that hour. remember the name of the card, and turn it back to its original position with its back up."

Turn your back to spectators. After your instructions have been followed, face audience again.

"You have thought of an hour and noted the card at that hour."

Pick up the cards, starting with ONE. Place ONE on TWO, TWO on THREE, etc. until all have been picked up. Square up the twelve cards and place them on the deck, keeping them separated by left little finger. Place deck behind your back.

"With the cards behind my back, I shall locate the card you selected. Quite easy as the selected card automatically turns over. Here it is now."

Hold the twelve cards as ONE, show quickly, and place them in your right trousers pocket.

"I shall place it temporarily in my pocket."

Bring pack up in front again.

"In order to check up, let us arrange the other cards in form of a clock dial again. What was the hour you selected, sir? Six o'clock, the gentleman says."



FIG. 16

Lay the cards down, starting with ONE o'clock and count the hours aloud, leaving a space for Six o'clock. Place rest of deck aside.

Figure 16.

Lay cards down with left hand. At the same time, place right hand in your trousers' pocket and locate the SIXTH card. Place it in front of the others so that you can reach it quickly when you need it.

"The Sixth card is missing from the clock."

Remove the selected card from your pocket and place it, face up, at six o'clock on the dial.

"Does this happen to be the card you selected? It is. Then all is well."

NOTE:

You may repeat the experiment in this manner. Have a card selected again. Then gather up the twelve cards and place them in your pocket BEHIND the eleven cards you already have there. Remove the eleven cards and place them on table, saying that the selected card still remains in your pocket. When you learn the number of the card, locate it quickly, and bring it out.

EFFECT:

Several cards are selected, marked if desired, and returned to deck. Deck is shuffled and dropped into a hat. Inside of the hat, cards are thoroughly shuffled around. Spectator is then asked to hold hat. Performer reaches into hat with his right hand and brings out, one at a time, the selected cards.

SECRET AND PATTERN:

Deck is shuffled. Have several cards selected and removed from deck. Each spectator may mark his card for identification.

Divide deck into two equal portions and have first spectator place his card on lower half. Place upper portion on this, keeping little finger of left hand over selected card. Riffle front edge of cards to give impression that deck is all together.

Go to second spectator. Divide deck again at point held by little finger and have second selected placed on top of first one. Spectators believe that you merely cut the deck at random each time to receive spectator's card. Close pack again with little finger in position.

Continue this until all selected cards have been gathered up. They are all together on top of the lower half of deck, over which you are holding your little finger.

Do the SIMPLIFIED PASS, bringing all the selected cards to the top of the deck. Also riffle shuffle the deck without disturbing position of selected cards.

"Several cards have been selected and returned to the deck and then shuffled well into the deck. To mix the cards even more, I shall drop them into this hat."

Drop cards into a derby or soft hat with a flat bottom. Place the cards with backs up. Shake the hat vigorously from side to side as though mixing the cards up. In reality, you can shake the hat from side to side without disturbing the order of the cards. Try it. They slide back and forth a little but do not mix. A little practice will give you the knack.

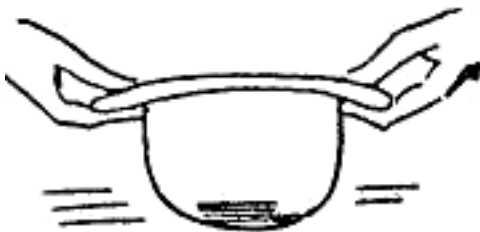


FIG. 17

Figure 17.

You may even give the hat an occasional shake up and down without disturbing the cards if you do it carefully.

"Now, I shall ask you, sir, to hold the hat up high for a few moments. You can first see that the cards are well mixed."

Let spectator look into hat and have him square up the deck. Then have him hold the hat up high enough so that no one can see into it.

Show both your hands, fingers wide apart.

"Ordinarily, it would be impossible to locate cards in such a mixed condition, yet, I find with sensitive fingers and an impressionistic mind that strange things happen."

Turn to spectator who placed his card in the deck last. His card is the top one on the deck.

"What was your card, sir? The Five of Hearts?"

Show right hand empty and reach into hat. Pull out top card and show it.

"There you are, sir. The Five of Hearts. Next!"

Continue this production of selected cards, taking the spectators in the reverse order in which they place their cards back into the deck.

* * *

12 - SELECTED CARDS FROM SPECTATOR'S POCKET

EFFECT:

Three cards are chosen, returned to deck, and shuffled in. Deck is placed in the empty inside coat pocket of a spectator. When Magician counts Three, spectator reaches into his pocket and produces one selected card. This is repeated until all three selected cards have been produced.

SECRET AND PATTERN:

After deck has been shuffled, have three cards selected by three spectators. Have the three cards returned to the deck as you did in the preceding experiment. They come on top of lower part of deck with little finger over them in preparation for the SIMPLIFIED PASS. Make the Pass and get cards to top of deck.

Riffle shuffle the deck, keeping the three selected cards at top of deck. Have a spectator come forward to assist you.

"Have you ever given a magical performance, sir? No! Good! Then, I shall let you give one this afternoon. I noted, as you were sitting there, that you possessed unusual magic powers. May I have the loan of your inside coat pocket?"

Sometimes a comedy touch is added here as spectator removes various papers and articles from his pocket.

"By using your own pocket, your magical powers will be strengthened."

Place the deck of cards in his pocket with backs of cards outward when coat is closed.

"As you know, three cards have been selected by various spectators, senators, office holders, and others in the audience. These were returned to the deck and lost somewhere in the shuffle. I really shouldn't say lost, even though to the rest of us they are lost, for I believe that at this very moment you, sir, know the exact position of each selected card."

Turn to spectator who last placed his card on the deck.

"May I ask the name of your card, sir? The Seven of Clubs?"

Now say to spectator assisting you:

"Hold your coat open with your right hand, and when I count THREE, reach into your pocket and with lightning-like rapidity, draw out a card with your left hand. Do not hesitate a moment, reach in, grab a card, and bring it out right away. Are you ready? One - two - three!"

Spectator reaches in quickly with left hand and grasps the card easiest to get at for you rush him. The card he invariably takes is the top card of the deck. When coat is held open, faces of cards are outward. When spectator reaches in, the farthest card away is the easiest for him to grasp.

Figures 18 and 19.

"There you are, sir, the Seven of Clubs. Like lightning, he finds them."

Continue this with the second spectator who selected a card, and finally with the first. When the three cards have been produced, take the deck from spectator's pocket.

"Tell your friends anything about your magic power, and if they didn't believe you before, they will now."



Harlan Tarbell

TARBELL SYSTEM, INCORPORATED, Chicago.

* * *

LESSON 35

Your next lesson gives you some master moves and manipulations in the field of Sleight of Hand with Cards. Some very interesting effects that will prove a welcome addition to your repertoire are also given you. This lesson is extremely valuable to you in developing your skill with cards.

(34-22)

SLEIGHT OF HAND WITH CARDS

Card Manipulation has always been very popular with conjurors. You can be a good magician without these sleights, but I am sure you will want to add them to your repertoire so that you can use them from time to time. To be an expert card manipulator, is of course, a great accomplishment, and if it is your desire to become one, this lesson will prove invaluable to you.

To become an expert in Sleight of Hand with Cards requires:

First: A careful analysis of the sleights.

Second: PRACTICE!

You cannot hope to become an expert card manipulator over night, nor in a week. The muscles of your hands must be trained gradually. At first your fingers will feel stiff and clumsy; but each time you practice, the moves become easier, more natural, and finally you find yourself doing them gracefully and well. It will give you keen pleasure to see the wonderful progress you make each time you practice these sleights.

Some performers use Hind's "Honey and Almond Cream" or some other good skin lotion on their hands just before doing manipulative work. You will find that it will help you, too.

The best cards to use are soft, uncalendered ones as they are more pliable than the enameled cards. Steamboat cards are most satisfactory. Cards with red and black plaid backs are popular because they are less visible in sleights than others.

All the sleights taught to you in this lesson are done with unprepared cards. Many of the sleights are not tricks in themselves, but are used in conjunction with tricks. They are all an important part of your magical education whether you perfect yourself in them or not.

Back and Front Hand Palming

EFFECT:

Performer takes a card or several cards between his thumb and fingers. With a slight wave of the hand, cards disappear. Magician turns his hand over and shows that they are not on the back. He continues to show back and front of hand empty, then suddenly produces the cards at his finger-tips.

TO PERFORM:

Start with a single card. After you have become proficient with one, try two, three, and as many as you can handle.



FIG. 1

Turn left side toward audience. Hold right hand out from body. Place a card in right hand between thumb and finger-tips.

Figure 1.



FIG. 2

Bring first finger over upper edge of card and little finger over lower edge.

Figure 2.



FIG 3

Curl second and third fingers under back of card and release thumb from card.

Figure 3.



FIG 4

Straighten second and third fingers and card is brought automatically to back of hand.

Figure 4.



FIG. 5

Figure 5 shows view away from audience. Card is held on back of hand, clipped between first and second fingers and between third and fourth fingers at about the first joints.



FIG. 6

To bring card back to front of hand, curl fingers in toward palm and place thumb on front of card.

Figure 6.



FIG 7

Hold card securely gripped and move fourth and first fingers along the edges almost up to the corners.

Figure 7.



FIG 8

Straighten second and third fingers and with tips of these fingers push card down well into palm of hand.

Figure 8.



FIG. 9

Figure 9 shows how card is held in palm. It is pressed against base of thumb and is clipped at outer corners between first and second and between third and fourth fingers.



FIG 10

To get card from this position to back of hand again, push up on card with base of thumb.

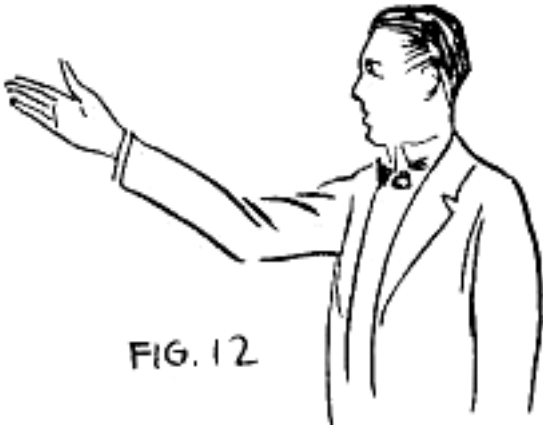
Figure 10.



Curl fingers inward toward palm, keeping fourth and first fingers well over the card.

Figure 11.

FIG. 11



Straighten hand out and card is pivoted to back of hand again.

Figure 12.

FIG. 12

PRACTICE THE MOVES UP TO HERE UNTIL YOU HAVE THEM MASTERED BEFORE YOU GO FURTHER. WHEN YOU CAN GET CARD FROM FRONT TO BACK OF HAND AND BACK AGAIN EASILY, THEN CONTINUE WITH NEXT STEP.

Now, you must learn how to turn your hand in Back and Front Hand Palming to show it empty. The card must be concealed as you turn your hand, and this is the way you do it:



You have turned the card over onto the back of your hand, and you show empty palm.

Figure 13.

FIG 13



Turn hand toward the front, bending fingers slightly in toward palm.

Figure 14.

FIG 14



Continue turning hand. As it comes to position shown in Figure 15, card comes into horizontal position and is thus screened from audience.

FIG. 15



SIDE VIEW
SHOWING HORIZONTAL
POSITION OF CARD

Figure 16 shows how card is held as hand turns. Audience does not see card at all as back of hand is toward them as in Figure 15.

FIG. 16

Grasp card with thumb, push it down into palm with second and third fingers and clip edges between fingers as taught to you in Figures 6, 7, 8, 9.



When card is in position with fingers straight, hold hand out with back toward audience. You have now shown front and back of hand with nothing apparently concealed.

FIG 17

Figure 17.

To bring card to back of hand again, reverse movements. Turn hand upward and backward while you get card to back of hand again as taught to you in Figures 10, 11, 12. When turning hand to show palm empty, start with Figure 17 and work back to Figure 13.

You may continue this Back and Front Palming two or three times. Study your ANGLES OF VISIBILITY very carefully so as not to expose the card.



FIG
18

TO PRODUCE CARD:

Have card on back of hand and palm toward audience. Curl fingers inward as in Figure 3. Grasp card between tip of second finger and thumb. Release bottom corner of card from little finger and allow card to spring up. Place first finger at rear of card also and produce as shown in Figure 18.

When you have mastered your lesson this far and your mirror shows you that you are getting along well, begin to practice Back and Front Hand Palming with more cards. First use two, then three, four, and five cards as you progress.



FIG. 19

It is a pretty effect to start with a fan of five cards in right hand. Square them up with one hand by pushing up with your little finger and down with first finger.

Figure 19.

When cards are all squared up, Back Palm them as one card and show palm of hand empty. Then turn hand and Front Palm the cards as one and show back of hand empty. Continue this two or three times.

TO PRODUCE CARDS IN A FAN:

Have cards on back of hand and palm toward audience. Follow method for producing one card, as taught above. When cards are at finger-tips, move thumb upward and fingers downward and cards will fan.

REMEMBER, THAT MOST SLEIGHTS ARE DONE RATHER QUICKLY.

Study and analyze them slowly, but keep practicing them faster and faster as you master them. You will find that after you know the movements, it is easier to do them fast. There is a certain speed necessary for graceful movements, yet do not

overdo it.

* * *

(35-4)

Simplified Back and Front Hand Palm

This is a favorite method of Paul Fuchs, a clever manipulator. It eliminates a number of movements and thus simplifies matters. You must watch ANGLES OF VISIBILITY carefully in this method.

TO PERFORM:

Back Palm card and show palm as in Figure 13. Turn hand in usual manner shown in Figures 14, 15, 16. Instead of straightening fingers, however, go only as far as Figure 15. Audience sees part of back of hand and believes that Magician has shown all of back of hand.

Then turn palm of hand to audience again, concealing card on back of hand.

This method is really nothing but a series of movements in which you open and close hand as you turn it.

This effect is very pleasing when Mr. Fuchs shows his hand empty and suddenly produces a fan of a dozen cards.

* * *

Production of Cards One at a Time from Back of Hand

Method 1--

A number of cards, say five, are Back Palmed on right hand and palm of hand is shown empty.



FIG. 20

Curl fingers inward and place thumb on corner of cards.

Figure 20.



FIG 21

Push outer card upward a little with thumb and release lower corner from little finger.

Figure 21.



FIG 22

Hold cards securely by pressing thumb down on second finger. Raise first finger and put it back of top card.

Figure 22.



FIG 23

Push first finger down to lower corner of outer card. Straighten fingers out, bringing remaining four cards on back of hand again. The produced card is exposed between thumb and first finger.

Figure 23.

(35-5)

Drop card to table or floor, then produce two more cards in the same manner. Before producing the last two, show both sides of hand empty and suddenly bring out the fourth card and then the fifth.

Many conjurers bring hand to position shown in Figure 15 as they produce each card and then to position in Figure 23.

This production requires artistic presentation. Practice until you can make the cards appear at your finger-tips as though you suddenly plucked them from the air.

Method 2-

The effect is similar to that produced by Method 1, but the mode of operation is different.



PULL CARD AWAY WITH THUMB CLEAR OF INDEX FINGER

FIG 24

Hand is in position in Figure 13 with cards on back. Curve fingers in and place thumb on outer card. Push down card with thumb until it is free of first finger.

Figure 24.



POSITION OF FIRST FINGER AS SEEN FROM ABOVE

FIG. 25

Bring index finger back of outer card.

Figure 25.



FIG. 26

Push index finger between outer card and remaining four cards. Grip outer card between thumb and back of first joint of index finger.

Figure 26.



FIG 27

Release lower corner of outer card from little finger.

Figure 27.



FIG. 28

Straighten fingers. The four cards are concealed again on back of hand and the produced card is shown between thumb and forefinger of right hand.

Figure 28.

* * *

Production of Cards One at a Time from Front of Hand

In this production back of hand is shown to audience.

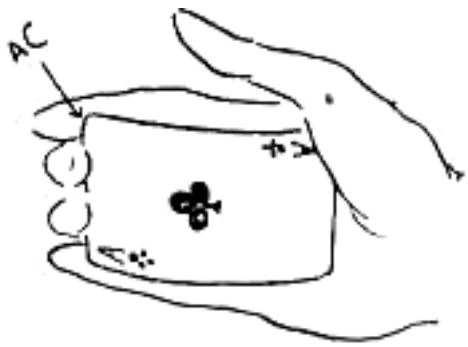


FIG 29

Palm several cards, say five, in regular fashion. Corner AC is gripped right in the ball of the forefinger.

Figure 29.

(35-6)



FIG 30

Place thumb on top card about half an inch from corner AC. Push outer card upward diagonally about an inch or so.

Figure 30.



FIG 31

Raise first finger and place it in front of corner AC.

Figure 31.



FIG 32

Grip corner between first and second fingers and pull card to horizontal position. Put thumb under card.

Figure 32.



FIG 33

With aid of thumb, push card into position shown in Figure 33.



FIG 34

Figure 34 shows how production looks to audience. Card appears suddenly at finger-tips as if it came out of the air.

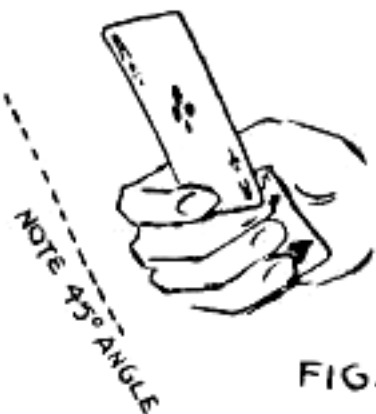


FIG. 35

NOTE:

The ANGLE OF VISIBILITY is very important in this production. Hold your hand at a 45-degree angle in relation to your body. You can then conceal the palmed cards well as you produce them, one at a time, even if fingers widen a bit during movements.

Figure 35.

Just before making the production, it is easy for you to palm off the cards from the deck. After you have produced these, palm a few more and continue the production if you desire.

This production is a favorite of Howard Thurston, one of the foremost Magicians of the day.

To Vanish Cards One at a Time and Produce Them Again

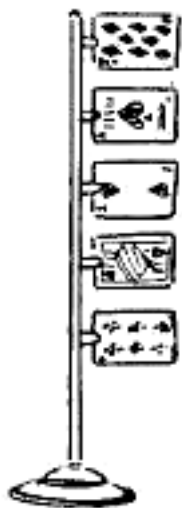


FIG.
36

A special stand for holding cards comes in handy for this effect. If you want to have one, secure a stand used for display purposes in show windows and have clips soldered on to it.

Figure 36.

(35-7)



It is not necessary to have the stand, however. Start with a fan of cards in your left hand -- say, five cards. Cards are fanned toward the right so that it will be easy to remove each one. If desired an assistant can hold cards.

Figure 37.

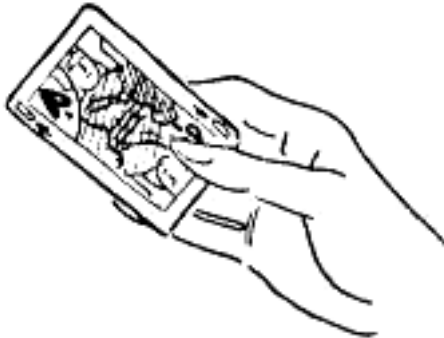


FIG 38

Take first card with right hand and with a slight tossing motion upward, vanish it on back of right hand. Then take next card in position shown in Figure 38.

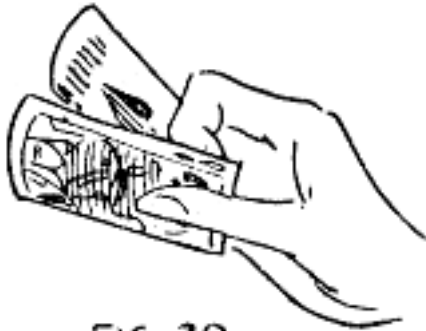


FIG. 39

Hold it even with first card in preparation for vanishing it also by Back Palming. Notice position of thumb.

Figure 39.

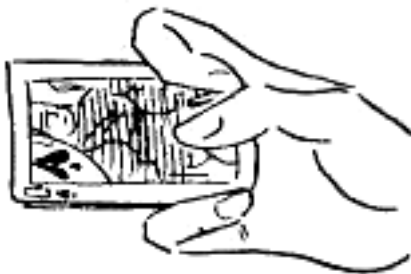


FIG 40

Curl fingers inward. Get the two cards together and Back Palm them both, thus vanishing the second card.

Figure 40.

Now by Back and Front Palming the two cards together, show both sides of right hand empty.

Vanish the remaining cards in the same way. It is not necessary to show both sides of hand after each vanish, but show them occasionally to convince audience that you have nothing concealed.

To produce cards again, use either method for producing cards one at a time, taught to you above. As cards are produced, place the first three in left hand in a fan.

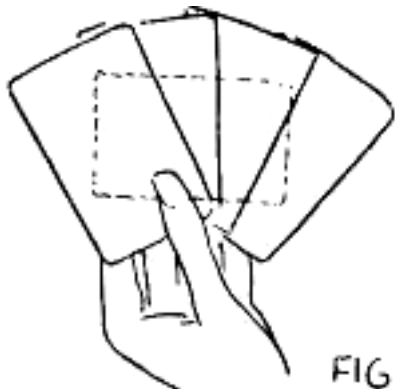
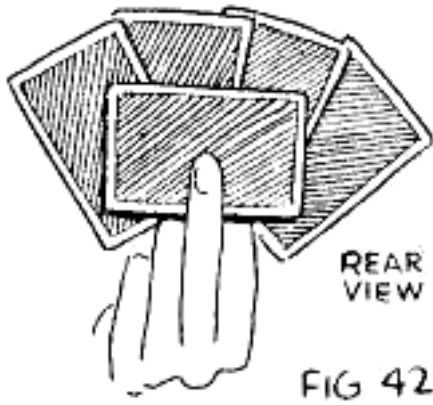


FIG 41

Produce the fourth card, and as you place it in fan in left hand, curl fingers of right hand inward and place fifth card in horizontal position BEHIND other four cards.

Figure 41 shows view toward audience.



Concealed card is held in place by second finger of left hand as right hand is immediately brought away from left.

Figure 42 shows view away from audience.

As you bring right hand away from left, keep fingers close together. Show back and front of hand as though you were Back and Front Palming a card. Keep thumb tight against hand to make it conspicuous. With back of hand toward audience, push thumb far up into palm of hand and suddenly open fingers. It looks as though you were concealing something in the palm of hand.

(35-8)

Close fingers again and quickly turn hand to expose palm, keeping thumb tight against first fingers as though holding something. Open fingers wide apart, one at a time, and finally the thumb. Now quickly show both sides of hand with fingers spread apart.



Bring right hand down to left. Starting with upper card, count the cards with thumb of right hand pointing to them and fingers back of cards. As you count -- Four -- Back Palm the concealed card in right hand.

Figure 43.

Grasp the fourth card between thumb and fingers of right hand and throw it aside. Then throw the other three cards aside, one at a time, tossing them up into the air. Show left hand empty.

Back and Front Palm remaining card in right hand to show right hand empty. Then suddenly produce fifth card at finger-tips and toss it into the air also.

This routine of manipulation may be varied. Some Magicians prefer using six cards instead of five and placing two

cards behind the fan instead of one.

* * *

Color Changes With Cards

The effect produced in a Color Change is this: The face of the "Bottom" card on the deck is shown. The hand is passed over the card and it suddenly changes to another number and color. You are given a number of methods. Select the one or two you like best.

THE PHANTOM PIP:

EFFECT:

Performer shows a Three of Spades on bottom of deck. He reaches up with right hand and apparently removes the center pip, leaving the Two of Spades. He snaps invisible pip into the air and shows right hand empty. Then he reaches into air again, gets invisible pip and puts it on the Two of Spades -- and behold, the Two changes back to the Three of Spades again.

TO PERFORM:

Place the Two of Spades on the "Top" of the deck and the Three of Spades on the "Bottom."



Hold deck in left hand with Three of Spades facing audience. Have your right side slightly turned to audience.

Figure 44.

"A very peculiar thing about the Three of Spades is that if you pass your hand over it in this direction, nothing happens to the card."



FIG 45

Pass right hand across deck from right to left. When hand gets to position shown in Figure 45, push the rear card, the Two of Spades, forward into the right hand so that it can be grasped between thumb and second joint of little finger.

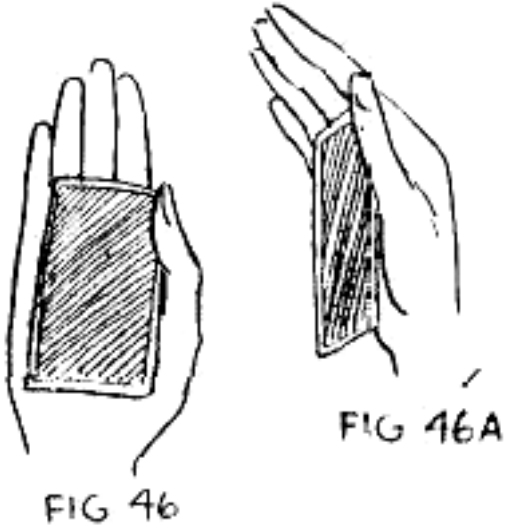


FIG 46

FIG 46A

Figure 46 shows the way the card is held in the right hand.

Figure 46A is the view from above as you see card in hand.



FIG 47

Figure 47 shows the way the left hand pushes card into right hand where only the two upper corners are gripped between right fingers.

The right hand must pass the deck in a continuous motion while it picks up the card. There must be no hesitation. Continue moving right hand to the left about 12 inches, raising it to show the Three of Spades again.

"But if you run your hand over the card in this direction."

Bring hand back across the deck and without stopping movement, place the Two of Spades over the Three. The moment card is in place pretend to pick off center pip of the Three spot. Remove right hand and show that center pip has been taken off and a Two spot is there instead of a Three. Toss invisible pip into the air.

"You can pick one of the pips off!"

JOG UP FRONT CARD

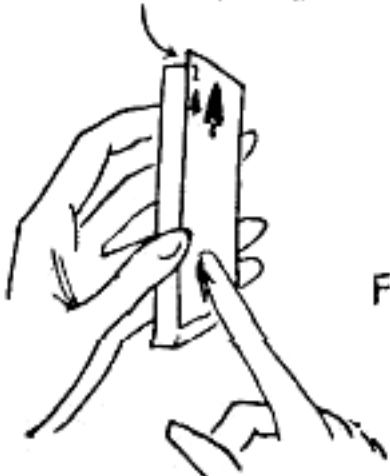


FIG 48

With right forefinger point to place where pip was and push card up about a quarter of an inch to get a jog at the top.

Figure 48.

Reach up into air to pretend to catch pip. Bring hand down over pack. Press down on jogged end of the Two of Spades. This forces the card into right hand where it is palmed.

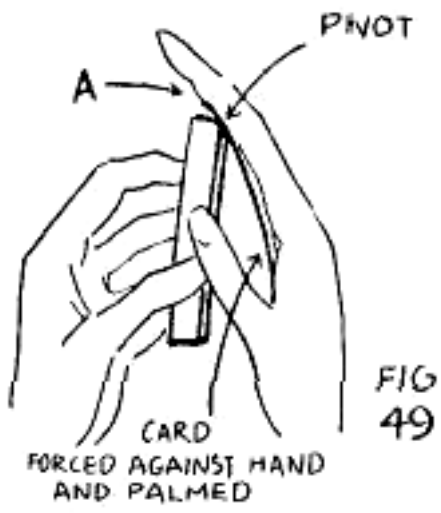


Figure 49 shows view from above as you see hands, but not as the audience sees them.

Bring right hand away to show the Three spot. The pip has apparently reappeared.

(35-10)

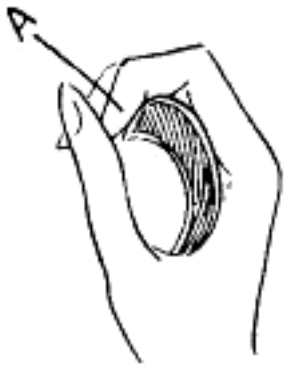


FIG
50

As you bring right hand toward your body, curve fingers inward until edge A can be held by thumb.

Figure 50.



FIG 51

Then bring right hand up to deck to point to center pip of the Three spot with fingers.

Figure 51.

CARD SHOOTS IN
BEHIND PACK



FIG. 52

Release edge A from thumb. This causes card to spring up behind deck. Hold it in place with rest of cards in left hand.

Figure 52.

Remove right hand from deck and show it empty. A good, natural move is to snap card into place under cover of transferring deck from left to right hand.

This last move of causing a palmed card to spring up behind the deck was given to me by Paul Fuchs, whom I mentioned earlier in this lesson. In his hands it is a beautiful piece of deception. It may be used in effects when you want to add one or more palmed cards to the back of the deck while the

front is exposed.

* * *

BACK HAND COLOR CHANGE:

EFFECT:

Face card on deck changes to a different number and color. This is another effect of Paul Fuchs.

TO PERFORM:

Turn left side toward audience. Hold deck in left hand with backs of cards toward rear. Place left little finger under top card in readiness for Palming. Curve fingers of right hand and place them against lower edge of card.



FIG 53

Figure 53.



FIG 54

Grip one edge of card between first and second fingers and other edge between third and fourth fingers in readiness for Back Palming. Straighten fingers and Back Palm the card. Place deck in right hand to show face card to audience.

Figure 54.

(35-11)

The Back Palming must be done in an instant as you pass the deck from left to right hand.



FIG 55

Bring left hand up past the deck to the right about 12 inches away. Do not cover cards. Move right hand up to left. Under cover of left hand, turn right hand enough to get Back Palmed card into left palm.

Figure 55.

Bring pack back to original position facing audience. Bring left hand with Palmed card back to the left over the deck.



FIG 56

Figure 56. The small diagram shows the movement of the left hand to the right over the deck and nothing happens to the exposed card.



FIG. 57

Now hand is brought back to the left and palmed card is placed over card on the deck. The moment card is in place, open fingers wide and continue motion of left hand to the left.

Figure 57.

The effect is that the color change came about with your fingers wide open. To the audience it appears that you merely moved right hand past left hand and card changed. This illusion is produced when you move right hand up to left.

(See Figure 55).

* * *

OPEN FINGER COLOR CHANGE:

EFFECT:

This is a fine color change as pack is in view all the time except for a moment when hand covers it once. Immediately fingers open wide, revealing the color change.

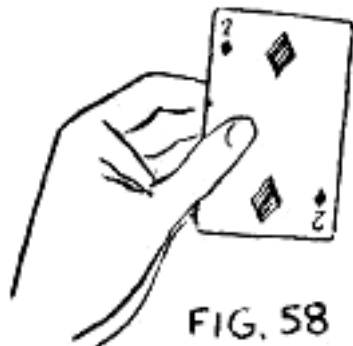


FIG. 58

TO PERFORM:

Hold deck in left hand. Right side is turned toward audience and left arm is extended about 18 inches from body. Face of "Bottom" card of deck is exposed to audience.

Figure 58.

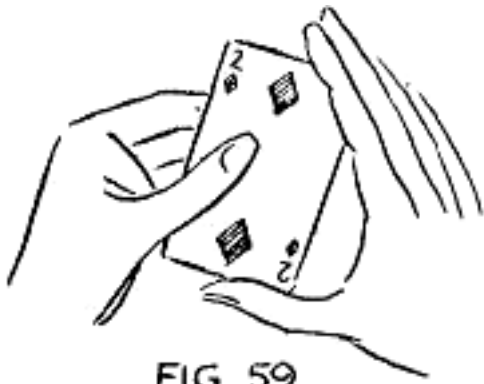


FIG 59

Bring right hand over to left to take deck. Grasp deck with thumb at bottom and first two fingers of right hand at top.

Figure 59.

The moment you grasp deck with right hand, push the "Top" or rear card down with left fingers into right hand until upper corner is gripped between third and fourth fingers and opposite corner at base of thumb.



FIG 60

Figure 60 shows view toward audience with back of right hand screening completely the card being pushed out.

(35-12)

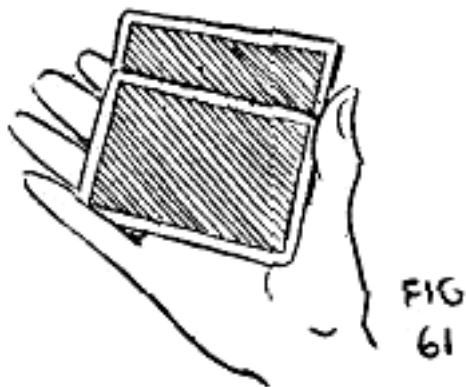


Figure 61 shows view away from audience with concealed card pushed into right hand.

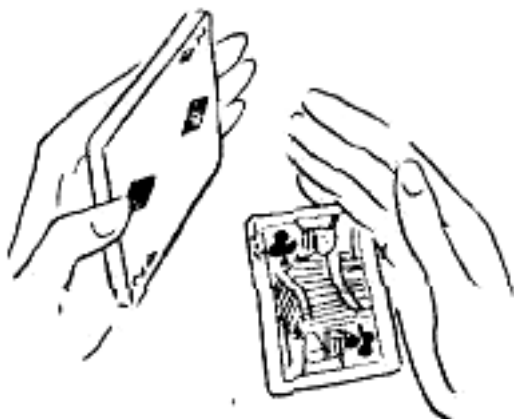


The moment card is adjusted, deck is held in right hand and left hand is shown empty.

Figure 62.



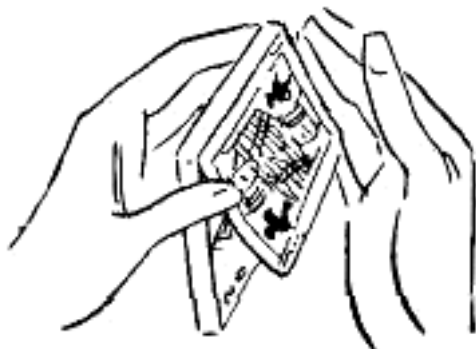
FIG 62



Transfer deck back to left hand, cards still facing audience. Release grip from thumb on concealed card in right hand and let it fall into horizontal position gripped between third and fourth fingers.

Figure 63 is view from above as you see hands.

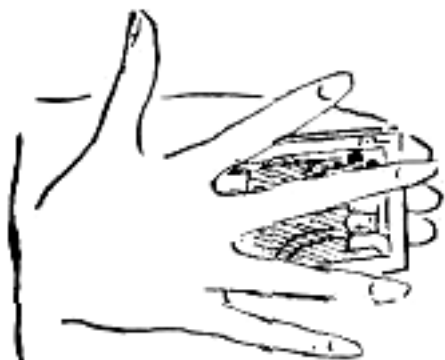
FIG 63



Hold right hand about six inches below deck to show front card on deck. Bring right hand up to deck and place concealed card on it.

Figure 64.

FIG 64



Place right hand over deck, immediately opening fingers wide so that audience can see sudden change of card through fingers.

Figure 65.

Remove right hand and show color change.

* * *

FIG 65

SLAP CHANGE:

EFFECT:

Face card of deck is slapped with right hand and when hand is removed, card is found to have changed to another. The striking of the cards adds smartness to this effect.

TO PERFORM:

Hold deck as in Figure 58. Show right hand empty, then grasp deck at top and bottom.

Figure 66.



FIG. 66

With second and third finger-tips of left hand push "Top" card into right palm.

Figure 67 shows view toward audience with card concealed in right palm.

(35-13)



FIG 67

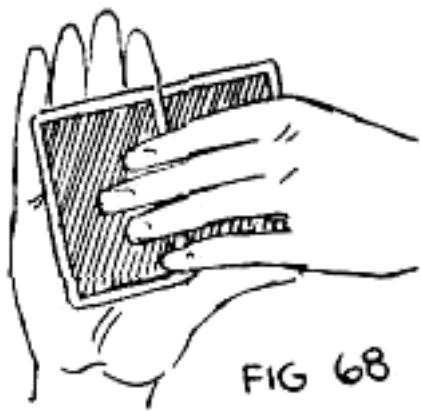


FIG 68

Figure 68 shows rear view away from audience, with concealed card Palmed in right hand.



FIG. 69

Separate hands and bring right hand back in front of left in preparation for slapping deck.

Figure 69.



FIG 70

Slap right hand down smartly on deck, leaving the Palmed card on the deck.

Figure 70.

Remove right hand and show that card has changed.

NOTE:

This experiment is often begun by holding deck as in Figure 66. Pack is then placed in left hand, and during this movement, "Top" card is slid into right palm.

This change may be used in producing selected cards. Three or four cards are selected by spectators and returned to deck. These are brought to "Top" of deck by the Simplified Pass. Each one is then in turn Palmed in right hand, as taught to you above, and produced on front of pack by the Slap Change Method.

PUSH UP COLOR CHANGE:

EFFECT:

This is similar to the change produced in the Phantom Pip.

TO PERFORM:

Hold cards as in Figure 71. With tip of left forefinger push rear card outward. Cards and hands are held horizontally. This view is from above as you see hands.

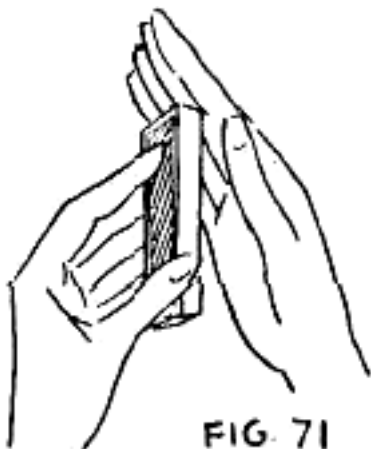
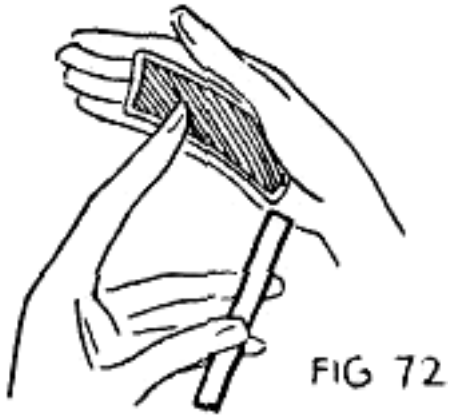


FIG 71



With aid of right hand and left forefinger, get rear card up into palm of right hand, where it is Palmed in regular fashion.

Figure 72.

Bring right hand back across pack again, placing Palmed card on front of pack. Remove hand and show change.

(35-14)

Use same "Patter" as in the PHANTOM PIP.

* * *

THUMB STEAL COLOR CHANGE:

TO PERFORM:



FIG 73

Hold deck in regular manner in left hand, faces of cards toward audience. Bring right hand up to deck, placing fingers in front of it and thumb behind it.

Figure 73.



FIG
74

Press down on rear card with right thumb and draw hand away, bringing card with it, gripped in crotch of thumb.

Figure 74.

Cover front card on deck with right hand, leaving concealed card on it. Then remove hand and show change of front card. Several cards can be slipped from back by pushing down with left forefinger and cards produced in fan from various

parts of body.

* * *

DOUBLE CARD CHANGE:

EFFECT:

In this experiment, two cards change instead of one.

TO PERFORM:

Split deck about in half and pull down outer section. Push up face card of rear section a little.

Figure 75.

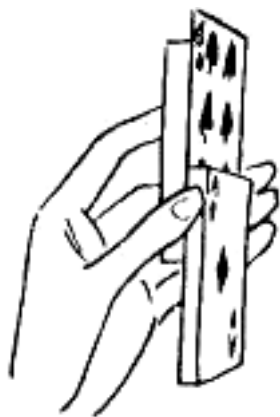


FIG 75

Pass right hand over upper section of deck. Push rear card forward with left forefinger until you can grasp it between thumb and little finger of right hand. Bring hand with Palmed card down in front of face card of upper section and grasp that card in similar manner. The two cards are now Palmed in right hand.

Figure 76.

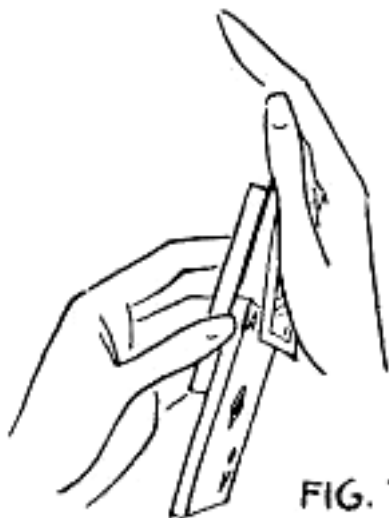


FIG. 76



FIG 77

As right hand passes back over the deck again, place the two Palmed cards on lower section of deck. Remove right hand and show it empty. Call attention to the double change on the deck.

Figure 77.

You may work this in pantomime or use this "Patter":

"If you pass your hand over the deck once, nothing happens."

Palm off the rear card, then show that cards are still the same.

(35-15)

"But if you pass your hand over them twice, one card changes."

Palm off face card of upper section, together with the rear card. Then show that one card has changed.

"However, the third time over, changes the bottom card as well."

Place cards over front card of lower section and show change.

* * *

SLIP UP COLOR CHANGE:

Credit for this is due to Charles Leedy, a fellow Magician.

TO PERFORM:

Deck is cut in two parts, one held in each hand. Keeping hands close together, drop part in right hand enough so that audience can see front card of left-hand section.

Figure 78.

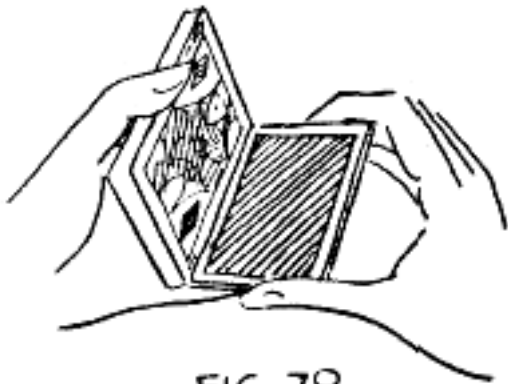


FIG. 78

Pull right-hand packet upward against left-hand one. As you do so, curve left fingers, press tight against "Bottom" card of right-hand section, and separate it from rest of section.

Figure 79.

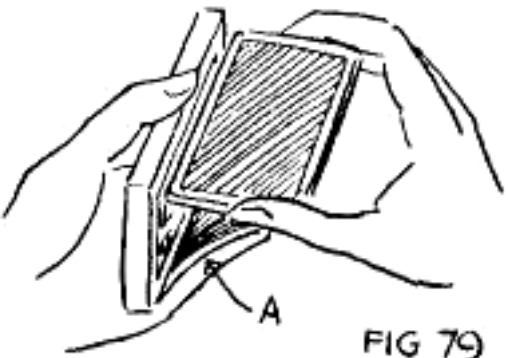


FIG 79

Remove right-hand packet and allow "Bottom" card to spring up against front of left-hand section. Bring right hand up high above left hand to show change of front card of left-hand section.

Figure 80.

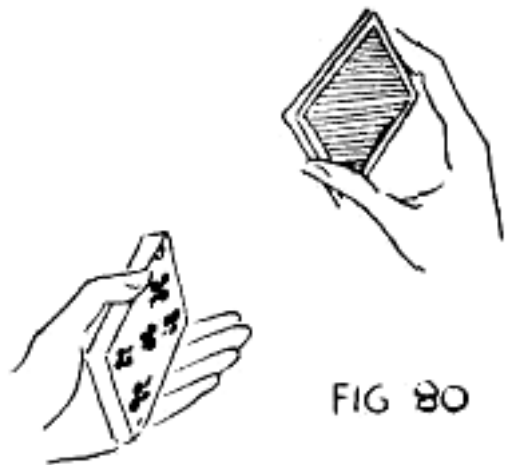


FIG 80

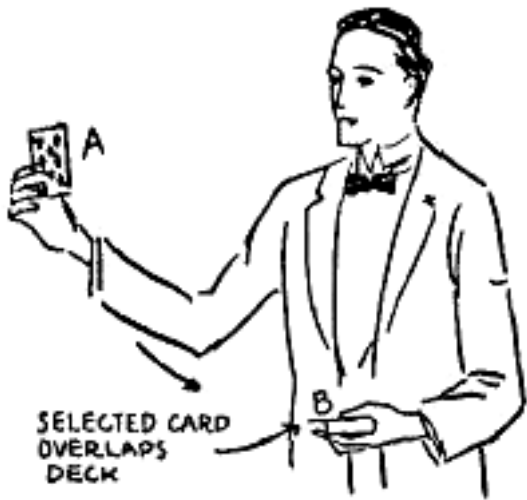
* * *

TOP CARD CHANGE:

This is very important in card work. The sleight has many uses. You may show front card of deck and suddenly cause it to change. You may locate a selected card by causing the front card to change into it, etc.

Method 1 --

Have a card selected, remembered, returned to middle of deck. Bring card to "Top" of deck with the Simplified Pass.



Riffle front edge of deck with right finger-tips, and as cards fall, have spectator tell you where to stop. When he says -- Stop -- you remove card at that point and show it. This is card A. Hold it between first and second fingers of right hand. Hold deck in left hand down at about your waistline. Push selected card -- B -- on top of deck over to right about half an inch.

Figure 81.

(35-16)

FIG. 81

Have spectator who selected card stand a little in front of you at your right and another spectator in the same position at your left.

Show card A to spectator at right.

"Is this the card you selected, sir? No?"

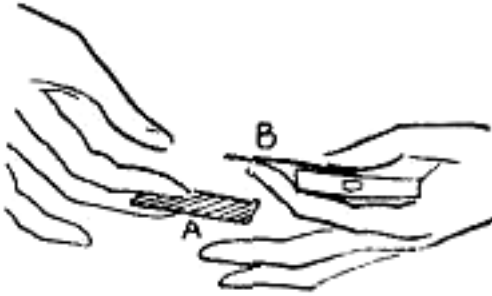


FIG 82

Turn to spectator at left. As you do so, bring card A up to left hand. Quickly place it between first and second fingers of left hand, and at the same time, grasp card B between thumb and first finger of right hand.

Figures 82 and 83.

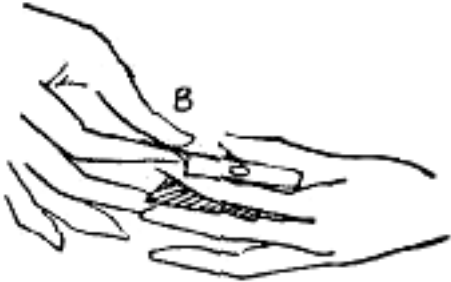
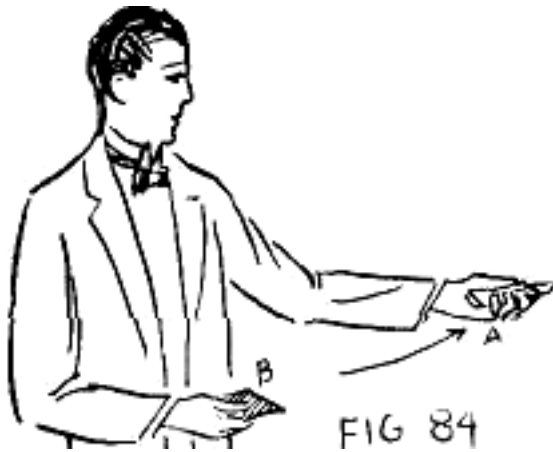


FIG. 83



Leave Card A in left hand and remove card B in right hand. Immediately move left hand to left, pointing forefinger to spectator and thus releasing card A, which now comes together with rest of pack. Hold B in right hand so that face is not exposed.

Figure 84.

You must not look at your hands in making this change and the audience will not suspect anything. They believe that you still hold card A in your right hand.

Say to spectator at left:

"Would you know the gentleman's card if you saw it?"

Then to spectator at right:

"By the way, what was the card you selected?"

Spectator names card.

"Blow on this indifferent card."

Have spectator blow on card B, then turn it over and show it to be selected card.

"I thought so!"

Method 2 --

This change is done without the spectators on each side of you, otherwise it is similar to Method 1.



Hold card up in right hand. You must look straight at audience, not at hands.

Figure 85.

Bring card down to pack, make the change, and bring card B above or below the pack about 12 inches. You must pretend to be making a gesture while you make the change.

(35-17)

Method 3 --

This is used when it is necessary to get card A to the top of the deck instead of the bottom.

Hold card A up between thumb and forefinger in right hand. Push card B to the right a little on deck.

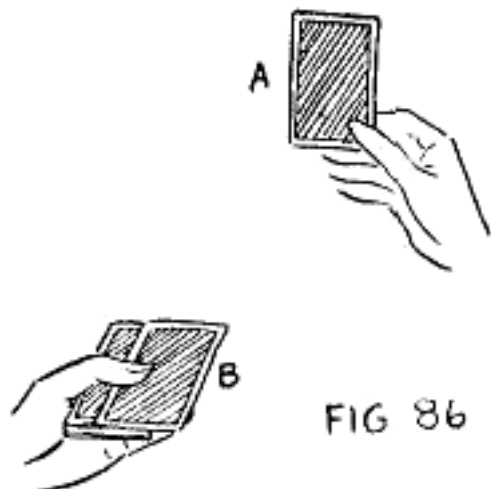
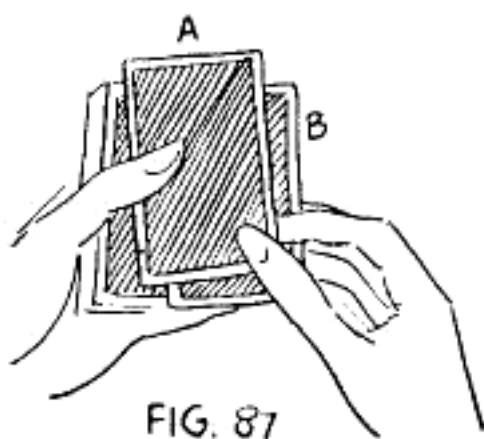
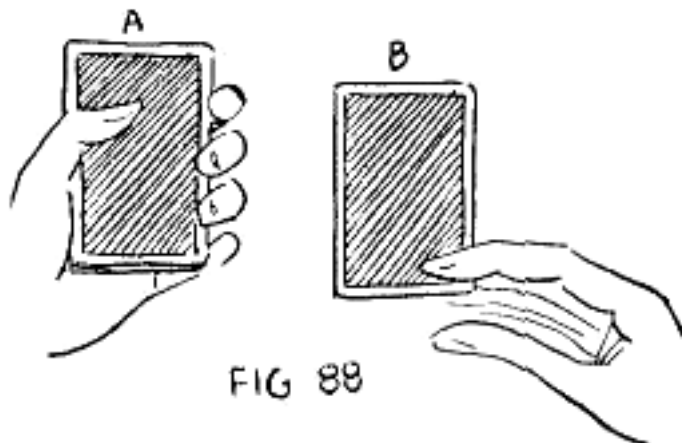


Figure 86 is a view away from audience as you see cards.



Bring card A down to pack. Grasp B between first and second fingers of right hand, and place thumb of left hand over A.

Figure 87.



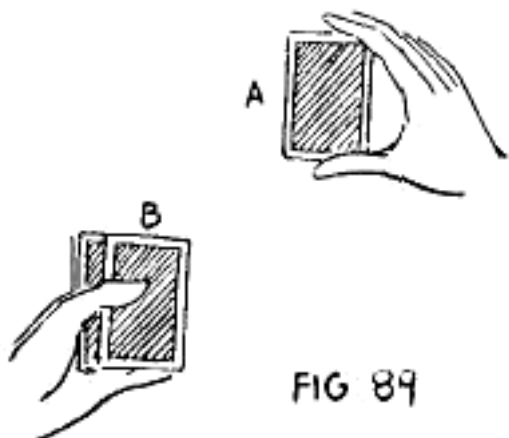
Separate hands, drawing B away in right and leaving A on top of pack -- and the change is made.

Figure 88.

This is a good change to use when turning body from left to right. First show A to people at left, then turn to right and show that card has changed.

Method 4 --

A good method for top card change.



Hold card A up in right hand with thumb at bottom and first two fingers at top. Hold deck in left hand with B pushed over to right.

Figure 89.

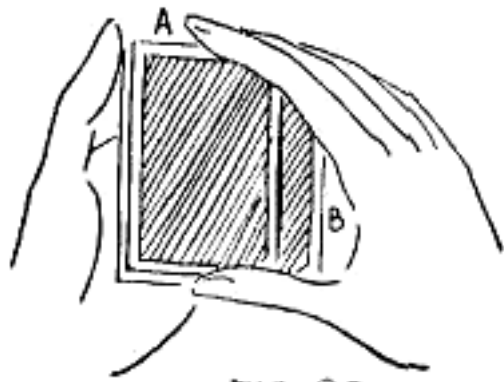


FIG 90

Bring A down on pack and grasp B between thumb and second finger of right hand.

Figure 90.

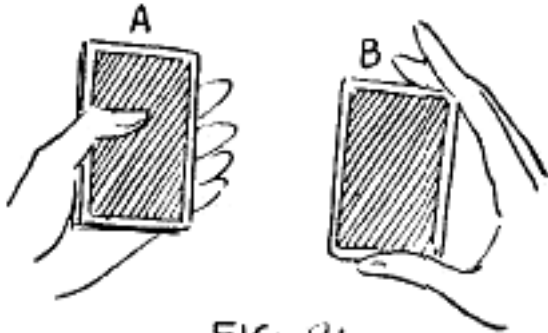


FIG 91

Draw right hand away with card B, and the change is made.

Figure 91.

This is a good change to use while turning body slightly from left to right. Make the change as right hand passes over the deck.

IMPORTANT:

STUDY THESE CHANGES CAREFULLY. WATCH YOUR ANGLES OF VISIBILITY AND NATURALNESS OF GESTURES. MAKE THE CHANGES UNDER COVER OF LARGER NATURAL MOVES, SUCH AS TURNING BODY SLIGHTLY OR PASSING HAND BACK AND FORTH OVER THE DECK. SPEAK TO A SPECTATOR DURING THE CHANGE AND KEEP YOUR EYES ON HIM, NOT ON HANDS, FOR MISDIRECTION. IT WILL PAY YOU TO PERFECT THESE CHANGES FOR THEY ARE THE BASIS FOR SOME GOOD CARD MAGIC.

Bottom Dealing

This requires practice, but when you have it mastered, you have a big trick up your sleeve. The method I teach you here is that used by Cardini, great English Magician. He does it so perfectly that the closest eye cannot detect that he is dealing from the bottom instead of the top of the deck.

EFFECT:

Performer deals off indifferent cards from top of deck and they suddenly change into selected cards (because of Bottom Dealing). Magician causes selected card to appear at any number in the deck which spectator chooses. Spectator then chooses any place in the deck and Magician deals off an Ace, apparently from that place, but in reality from the bottom of the deck.



TO PERFORM:

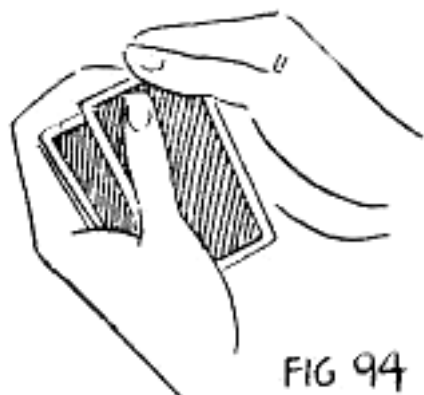
Hold deck in left hand, backs of cards up. Curve fingers upward and press cards firmly against base of thumb.

Figure 92.



Move top card over to the right with thumb.

Figure 93.



Place right thumb at corner of top card and first finger of right hand under bottom card of deck in left hand.

Figure 94 shows view from above.



Figure 95 shows view from underneath to make finger positions clear to you.

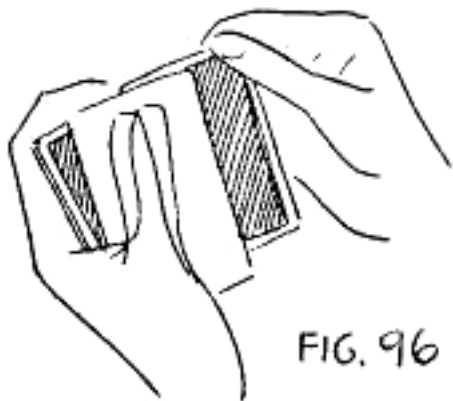


FIG. 96

Pull out bottom card, holding it between thumb and first finger of right hand. Card comes straight out from deck. At the same time, draw top card back onto deck with left thumb.

Figure 96.

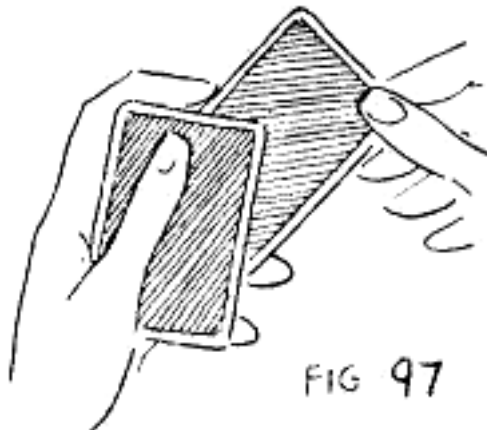


FIG 97

Bottom card may be removed diagonally instead of straight if desired. Figure 97 shows method of doing this. Top card is shown already squared up on deck by left thumb.

When Cardini deals from the bottom, as he pulls card away in right hand, he throws left hand with a turn to the left and snaps card down on the table with the right. He deals as fast from the bottom as he does from the top.

Study your motions so that there is no apparent difference between regular dealing and bottom dealing. Practice well the art of sliding top card back and forth easily with left thumb.

Dealing Seconds

Another handy sleight for apparently dealing from top but in reality dealing the second card from top. This is the method Cardini uses.

EFFECT:

Performer deals cards from top, apparently, but really holds back top card as long as he desires. Cards are made to appear at any number between one and ten.

TO PERFORM:

Hold deck in left hand. First finger is at outer edge of cards and little finger is at lower corner. Thumb is well back toward left edge of deck.

Figure 98.

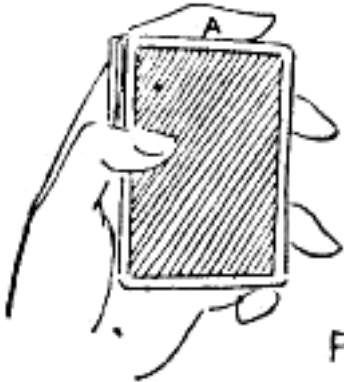


FIG. 98

Push left thumb to right, thrusting TWO cards with it. Bring right hand to deck. Place thumb over card A and first two fingers under card B.

Figure 99.

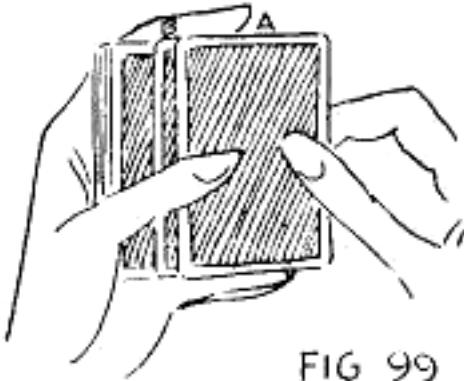


FIG 99

Draw left thumb back to original position, bringing top card A with it. This leaves second card B in right hand.

Figure 100.

Snap card down on table with right hand and move left hand to left a little.

Dealing must be done in a natural manner without looking at deck. Both Bottom and Second Dealing should be done with the sense of touch.

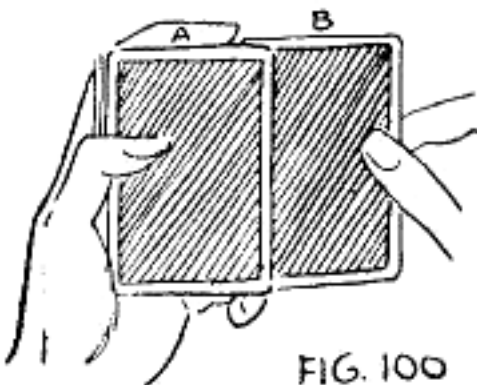


FIG. 100

* * *

Modern Card Change

This is a good method for indetectably changing one card to another.

TO PERFORM:

Get selected card to top of deck. Do the Double Card Lift, showing face of second card from top as top card. Place the two cards on bottom of deck so that they extend a little to the right. Hold deck in left hand with cards facing audience.

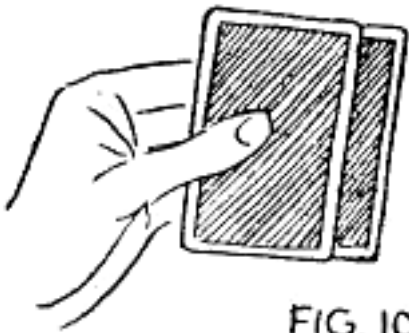


FIG. 101

Figure 101 is view as you see cards.

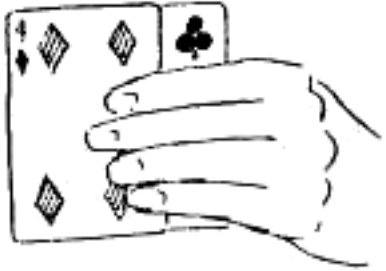


FIG 102

Figure 102 shows how cards are held toward audience. Thumb is at rear and fingers in front of deck.

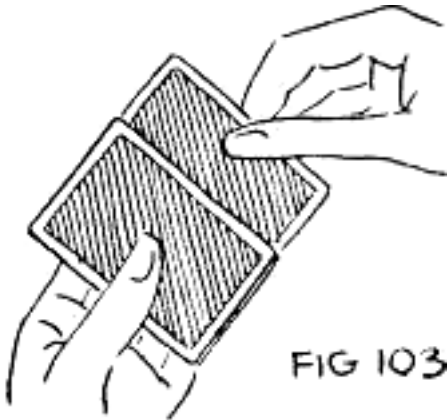


FIG 103

Turn cards so that audience can see the backs. Place right thumb back of second or selected card and fingers in front of the first card at bottom of deck.

Figure 103.

Remove the second card with right hand and at the same time, push the first card back with left fingers, squarely on to the deck.



REAR VIEW

FIG. 104

Figure 104 shows this move from underneath. The first card is square upon the deck and second card is about to be removed in right hand.

Separate hands. Right hand carries card to the right side with back of it still to audience. Audience believes it to be the first card which they saw. Turn card over and show it to be the selected one.

Be careful not to expose first card at bottom of deck in left hand.

* * *

Single Hand Card Change

This change is performed with one hand.



FIG. 105

TWO CARDS HELD AS ONE

TO PERFORM:

Lift two cards from top of deck and show as one. Hold in right palm with lower corner in crotch of thumb.

Figure 105.



FIG. 106

Turn hand over, and as you do so, curl in your fingers.

Figure 106.

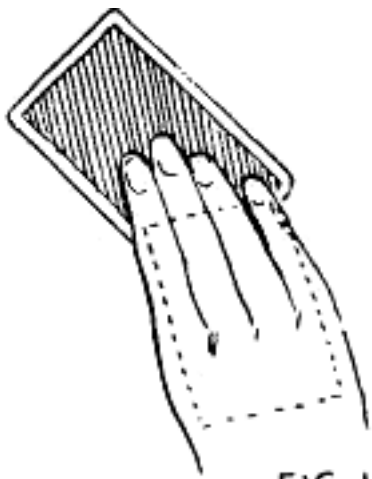


FIG. 107

Straighten fingers out again, forcing top card out to tips of fingers and second card back into palm of hand where it is Thumb Palmed.

Figure 107.

Force top card out on to table. Bring right hand quickly back to deck in left hand and place concealed card on top of deck. Card on table is shown to have changed.

This move may be made to appear natural by throwing card to table with right hand and merely finishing the movement by bringing right hand back to deck.

* * *

The Ribbon Drop

EFFECT:

A pretty card flourish in which cards drop quickly and evenly from right hand down to left, held about 12 inches below. The even dropping gives the effect of a ribbon. Use new cards to get the best results.

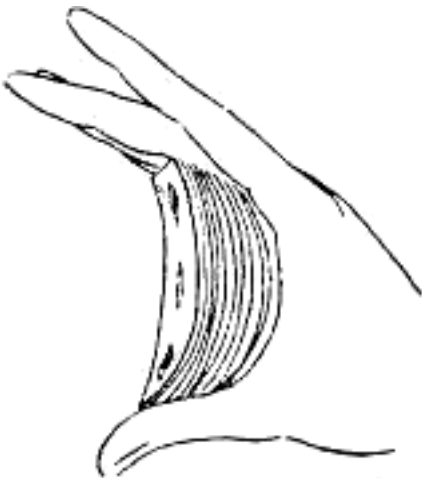


FIG. 108

TO PERFORM:

Turn left side to audience. Hold cards in right hand as shown in Figure 108. The grip comes between thumb and second finger, and the other fingers assist lightly in holding cards. Push second finger and thumb inward a little so that pack is curved and cards spread slightly apart.

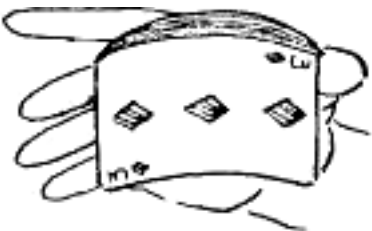


FIG. 109

Turn right hand to horizontal position, holding it at about a 45-degree angle.

Figure 109.



FIG. 110

Hold left hand 12 to 18 inches below right. Gradually release pressure on cards with thumb and second finger. Allow the cards to fall evenly in a ribbon effect into left hand. Cards face audience.

Figure 110.

It takes practice to master this flourish, but when perfected, it is pretty.

The Cascade

EFFECT:

This is similar to The Ribbon Drop but the cards are curved and fall in a cascade.

TO PERFORM:

Hold cards in the same way as you do for The Ribbon Drop, but press down harder on the cards to get a greater curve in them.

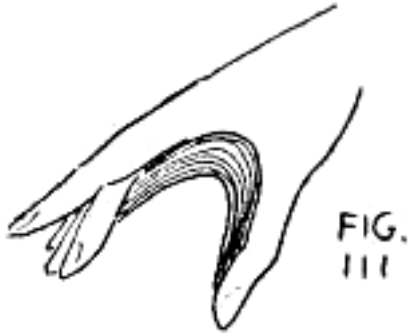
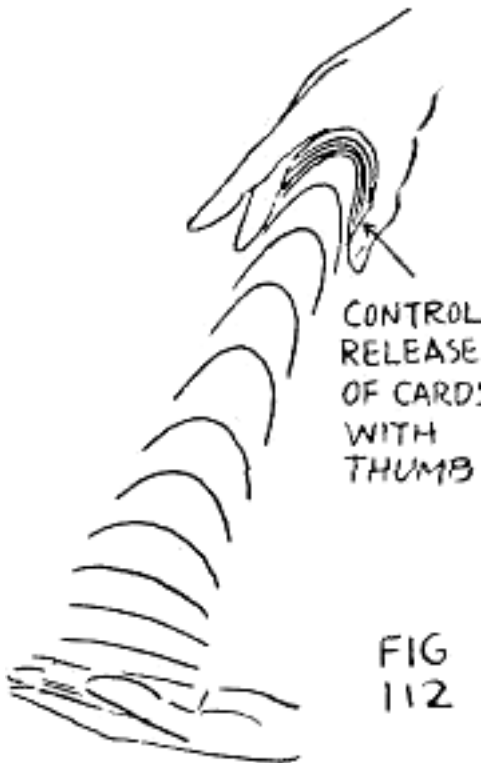


Figure 111.

Release pressure on cards with THUMB and draw thumb back over edges of cards a little. This causes the cards to fall one after another rapidly into left hand. CONTROL OF THE CARDS IS WITH THE THUMB. Cards fall with faces downward and edges to audience.

Figure 112.



Another method of Cascading cards is to force the cards across from right to left hand horizontally.

Figure 113.



* * *

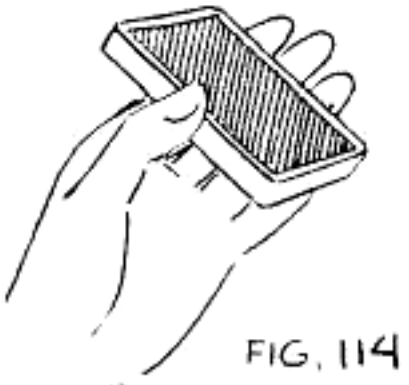
The One-Handed Cut

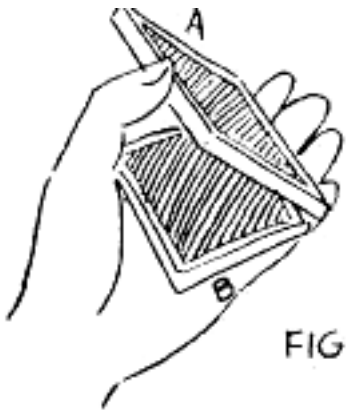
Another flourish with cards in which the pack is cut while held in one hand.

TO PERFORM:

Hold pack between fingers and thumb, backs of cards up.

Figure 114.



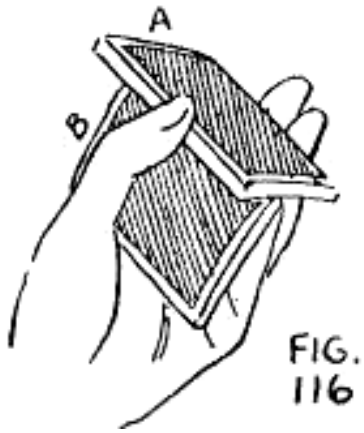


Allow about half of the pack to drop into palm, making sections A and B.

Figure 115.

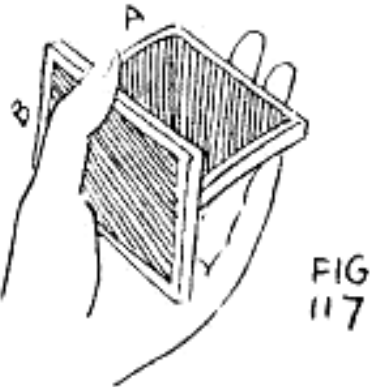
(35-23)

FIG. 115



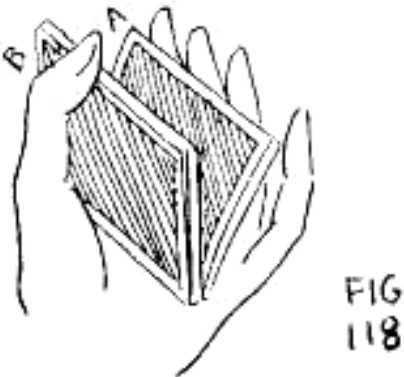
With tips of FIRST finger and LITTLE finger, push against B, raising it up under A.

Figure 116.



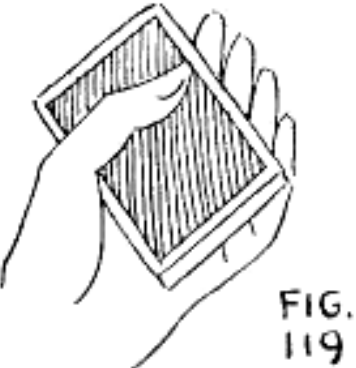
Continue raising B until it is free of A and A drops down toward palm.

Figure 117.



The moment B is free from A, transfer first finger to A to control it and lower it evenly.

Figure 118.



When A has dropped into position, let B fall on top of it and the cut is completed.

Figure 119.

PRACTICE THIS CUT WITH BOTH HANDS. Then try holding half of deck in each hand and cutting them simultaneously. This method of cutting is similar to the REGULAR PASS.

* * *

This lesson has covered some interesting and valuable card sleights. With a little ingenuity on your part, you can work them into many tricks. You can introduce flourishes and production and vanishing of cards here and there for variety. A number of methods for doing the same thing are taught to you so that you can pick out the method which is easiest for you and which you like best. Practice and perfect the methods which suit you best.

Harlan Tarbell

TARBELL SYSTEM, INCORPORATED, Chicago.

* * *

LESSON 36

More wonderful card effects in this lesson -- effects used by great magicians and other clever effects which you will be mighty glad to know and use. Experiments with Four Aces, with Rising Cards, and with Fountains of Cards.

MORE CARD MAGIC

When you have mastered this lesson, you will be able to handle a deck of cards in true professional style. You will have a foundation of principles to use as a basis for many effects and many combinations. You will be prepared with methods of handling cards to carry you through almost any emergency.

I teach you Card Magic with a regular deck of cards, purposely avoiding effects which require specially printed cards. I want you to know how to perform with an ordinary deck so that you are ready for impromptu work, for emergency work. You can add fake cards to your work later on, if you desire to. They are not difficult to obtain. But right now, I want to feel that you are learning real Sleight of Hand with Cards and have the ability to take your place in the field of Card Magic as a real Sleight of Hand performer.

This lesson is very interesting.

You learn--

COMEDY FLOURISHES

EASY METHODS OF FORCING A CARD

METHODS FOR FALSE COUNTING

FOUR ACE EFFECTS

RISING CARDS THROUGH THE AIR

CARD FOUNTAINS

* * *

PRODUCTION OF CARDS FROM THE MOUTH

EFFECT:

This is a comedy flourish. Magician reaches up with his hand and apparently takes many cards from his mouth, or from a boy's mouth.

TO PERFORM:

Palm off from the deck a dozen cards, or as many as you can conveniently palm, in your right hand. It is preferable to palm them with faces of cards against hand. To do this, hold deck in left hand right in front of you with faces of cards toward you and backs toward audience. Place right hand over deck. Turn toward the left, and as you do so, get left little finger under a dozen or so cards. With aid of little finger, palm the cards in right hand.

Place cards up against mouth with back of hand to audience, being careful to conceal cards. Push top of cards up into mouth about an inch.

Figure 1.



FIG



FIG. 2

Draw right hand aside and place left hand on cards also. Immediately start pulling cards down in ribbon fashion, allowing them to fall one by one to the floor. As you pull cards down with fingers of both hands, you create the illusion of actually pulling the cards out of your mouth.

Figure 2.



FIG. 3

If you do this with a boy, have him face audience. Stand behind him, and under cover of his body, palm your cards. Reach your arms around his neck, place cards up into his mouth a little way, and immediately start pulling cards down.

Figure 3.

CASCADE PRODUCTION FROM BOY'S NOSE

EFFECT:

Another comedy flourish in which performer places his hand on boy's nose and a stream of cards cascades down.

TO PERFORM:

Stand behind boy and palm off half the deck in right hand. Hold cards as you were taught to do for the CASCADE DROP in Lesson 35.

Step around to right of boy, place your right hand up to his nose, and cascade the cards downward, allowing them to fall to the floor. Tilt your hand a little to get proper angle for a good waterfall or cascade of the cards. This stream of cards, apparently coming from the boy's nose, always gets a laugh.

Figure 4.



FIG. 4

* * *

EASY METHODS FOR FORCING CARDS

I have already shown you how to force a card on a spectator in a previous lesson. There are other methods which you should know. These which I give you here are easy and give you a good variety. You will find them most useful.

The Mathematical Force --

EFFECT:

Performer makes a selected card appear at any number from the top of the deck which spectator chooses. To save time, spectator is asked to choose number between one and twenty.

TO PERFORM:

Have card freely selected and then returned to middle of deck. Allow TWO cards from upper packet to fall on selected card. Place left little finger on top of these two cards, do the Simplified Pass to get them and the selected card to top of deck. Selected card is now third down from top.

Ask spectator to select a number under twenty. Suppose TEN is the selected number.

Hold cards with backs up in left hand. Count down 12 cards quickly, one on top of the other, placing them on table. Count each card aloud as you deal it. Then say,

"Pardon me, what number did you say?"

Spectator says he chose number 10. Quickly replace the 12 cards on the deck.

"My mistake. Ten cards, you say."

By counting the cards down on the table, you have reversed the order of them. Originally you had two indifferent cards on top of the deck and the selected card third from the top. Now, by counting two more cards than the selected number, you bring the selected card just at the selected number down from the top. Spectators do not realize that you have reversed order of cards and stacked them so as to bring selected card into position.

Regardless of what number is chosen, count down TWO more in the first counting. Then replace all the cards on the deck.

Now you can proceed to count down to the tenth card. After you have counted nine, have spectator take tenth card -- and this proves to be the selected one.

NOTE:

If number 1 is chosen, fan cards enough to get left little finger under top three cards. Lift the three cards as ONE with right hand and show face card as selected card.

If number 2 is called, deal off the first card on the table. Then for second card, deal SECONDS as you were taught

in Lesson 35. This will bring out the selected card as the second card.

If number 3 is called, merely count down the two indifferent cards and show the third as selected one.

If number 4 is called, you may proceed in the regular way or else FALSE COUNT three cards as four and show selected card.

If you want to use this method for forcing a card, select the card you want forced and place it third from top of deck before beginning experiment. Then have spectator select number and proceed as above to get the forced card. Spectator believes he has had free choice, but you have brought out the card you want used. Then you can proceed with the experiment you want to perform with forced card.

* * *

Forcing Bottom Card --

EFFECT:

Cards are fanned and spectator is asked to select one by touching it. Magician separates pack at that point and shows card which had been touched. This is in reality the card magician wanted selected.

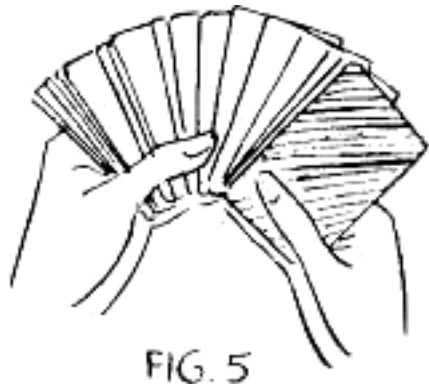


FIG. 5

TO PERFORM:

Place card to be forced, say the Ace of Diamonds, on "Bottom" of deck. Fan cards, backs up.

Figure 5.

AS SEEN FROM UNDERNEATH



FIG. 6

With right finger-tips move bottom card over to center of fan under other cards. Movement and shifted card are concealed by fan of cards.

Figure 6.

Have spectator touch any card in fan. He will usually touch one in the middle somewhere, but wherever he touches, separate the pack at that point. Be sure to get the card he touched in the right-hand pack. Bring the bottom card quickly up even with bottom card of right packet (spectator's touched card) and pull two hands apart. The Ace of Diamonds becomes bottom card of right packet.

It is apparently the card spectator touched, but in reality is a forced card. Hold right packet facing audience to show selected card.



Figure 7.

You may now proceed with the experiment which you desire to perform with the forced card.

If you want to force three or four cards, place them on bottom of deck and force each by the same method as above. Be careful not to expose bottom of left packet.

This force is always sure. It is easy to do and cannot be discovered by audience if you do it right. This is also a good method for locating one or more selected cards.

* * *

Force Behind Performer's Back --

EFFECT:

Performer places deck behind his back, and spectator selects a card. This card is forced.



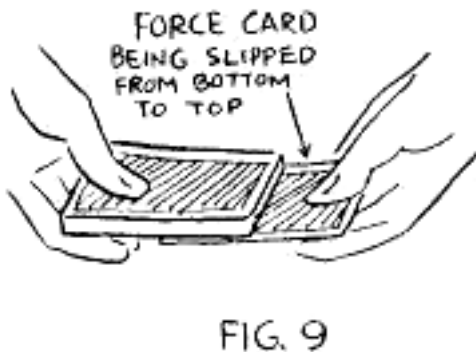
TO PERFORM:

Place card to be forced on bottom of deck. Be careful not to expose it. Place pack behind your back, holding cards in both hands lightly. Backs of cards are up.

Figure 8.

Ask spectator to lift off a few cards. When he has done so, turn to the left to face him for an instant. Cards are kept in same position behind your back and are now out of sight of audience.

"Did you take off a few?"



The moment cards are hidden, slip the bottom card to the top. Do this quickly with right hand.

Figure 9.

Turn your back to spectator again with cards behind you as before. This turning and adjusting of cards is done so quickly that audience does not suspect anything. It seems natural for you to turn to spectator as you ask him whether he took a few cards.

"Now that you have lifted off a few cards from the deck - I do not know how many -- just lift up the next card and look at it. Remember it."

And so you have forced your card.

THE CIRCUS TRICK

This is a good effect which you may perform after you have forced a card by above method.

TO PERFORM:

After spectator has looked at Forced Card, tell him to place it with other cards in his hand and shuffle it in well. Then give him rest of deck, telling him to place all the cards together and shuffle them. Then take deck.

"This is a circus trick, in days gone by performed by the fakers who used to follow the circus. This was one of the old standbys like Three Card Monte and the old Shell Game. The object is to find your card by a mental process. Now, I shall deal the cards, face up and one at a time, on the table. As your card is turned up, I want you to say, 'Stop!' mentally. The moment you think -- Stop -- I shall tell you your card. Sometimes it is difficult to tell the card on first impression. If I fail, say nothing. Do not help me. Make no noise or motion besides a mental Stop."

Hold deck in left hand, backs of cards up. Turn over top card and place it on table, face up. Continue to do this, placing one card on top of the other, until you come to selected card. Do not stop here but continue to deal off three or four more cards on table, allowing part of selected card to show from under others.

Take hold of top card on deck and remove it half way but do not expose face. Then say to spectator:

"Would you be willing to wager that the NEXT card I turn over will NOT be your card? Personally, I have a hunch it is. I might say at this stage that there are no two cards in the deck alike."

Draw attention to the card half way off the deck. Spectator thinks you are referring to that card. He knows that selected card is on the table, so he probably says that the next card you turn over will not be his card.

"This is a circus trick, and I would not wager with you because you would be sure to lose. When a person bets that the next card turned over will not be his card, performer reaches down and turns over the selected card which is already on the table."

As you say this, reach down and turn over the selected card on the table.

"Was that your card? That's a warning to you to be careful how you bet."

The Riffle Force --

EFFECT:

Spectator is asked to think of any card in the deck as cards are riffled. Spectator is forced to think of certain card.



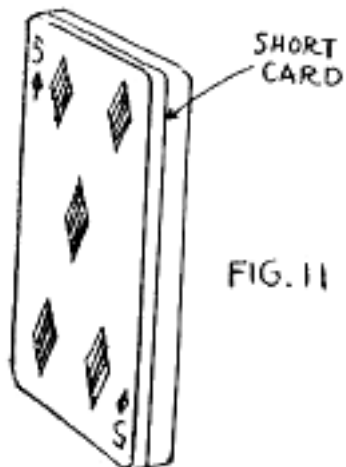
TO PERFORM:

This force requires what is known in Magic as a SHORT CARD. You prepare it this way: Trim off with a pair of sharp scissors a small edge from one end of a card from 1/32 to 1/16 of an inch. Trim the corners down, rounding them to look like those of ordinary card.

Figure 10.

This Short Card looks like any other card. The difference is so slight that even keen eyes would not notice it. When this is mixed into the deck, it can readily be located by riffling top of cards with the thumb. The moment this short card slips by thumb, there is a snap and a little hesitation in the riffling.

FIG. 10



Suppose you want to force the Ace of Hearts. Place the Short Card in front of the Ace and place both cards about 1/3 to 1/2 of the way back from front of deck.

Figure 11.

FIG. 11



Hold deck in left hand and riffle top edge with right thumb. Do this fast so that eyes of spectator will not have a chance to concentrate on any one card. When your thumb reaches short card, this card snaps forward and exposes the Ace of Hearts a little longer than any of the other cards. Spectator concentrates on this card and selects it. Rest of cards are riffled through rapidly.

FIG. 12

Figure 12.

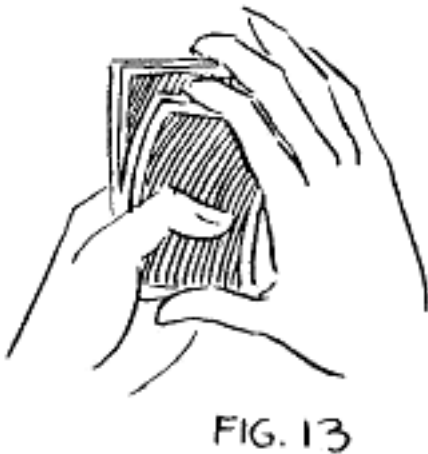
Spectator thinks he has freely selected the card, but he really had no chance to see any card long enough to remember but the forced card. Experience will teach you just how fast to riffle the cards and how long to hesitate on the forced one. This hesitation must not be noticeable but just long enough to get the result.

Say to spectator:

"I am going to riffle the cards, and as I do so, I want you to THINK of any one of the cards as they pass by. I want you to make a deep mental impression of one card and remember, it. Choose any card except the bottom one. Do not select one in advance, but select ONE of the cards as they riffle by."

Riffle the cards and force the desired one. You may then proceed with experiment for which you forced the card.

(36-7)



You keep backs of cards toward yourself. You need not see faces of cards. If you find it easier, you may riffle with first finger.

Figure 13.

* * *

Riffle Force with Unprepared Cards --

TO PERFORM:

This riffle force is done with unprepared cards and no Short Card. In this case, keep faces of cards turned so that you can see them. Tell spectator to remember a card as you riffle. Start riffling cards rapidly, then about one-third way back in the deck, hesitate a moment and allow a card at this point to be shown longer. Then continue riffling fast. Remember card at which you hesitated.

Now look through cards and get selected card to top of deck. Lift the two top cards as ONE and show face of second.

"This, I believe, is the card you thought of. No?"

Replace the two cards on deck. Then remove top card, back up.

"What was your card?"

Spectator names card. Turn top card over and show it.

"That's what I thought!"

NOTE:

If you fail to locate card the first time, show spectator card in your hand and say:

"Did you notice something peculiar? Is this the card I first showed you? No. It has changed. Look at it closely."

Give him the first card you selected. Hurriedly look through the deck for the second selected card and get this to top of deck.

"Strange, it isn't even in the deck."

Take card back from spectator.

"Are you sure you thought of the Seven of Diamonds?" --
(or whatever selected card happens to be.)

As you say this, do the card change, placing this card on bottom of deck, and take top card which is selected card.

"I do not understand it."

Then turn card over and show it to be selected one.

"Well, it happened to be your card, after all."

* * *

Forcing One of Four Cards on Table --

EFFECT:

Four cards are laid down on table in a row. Through various methods, Magician can force any one of the cards.

TO PERFORM:

Place four cards down in this manner, backs up.

Figure 14.

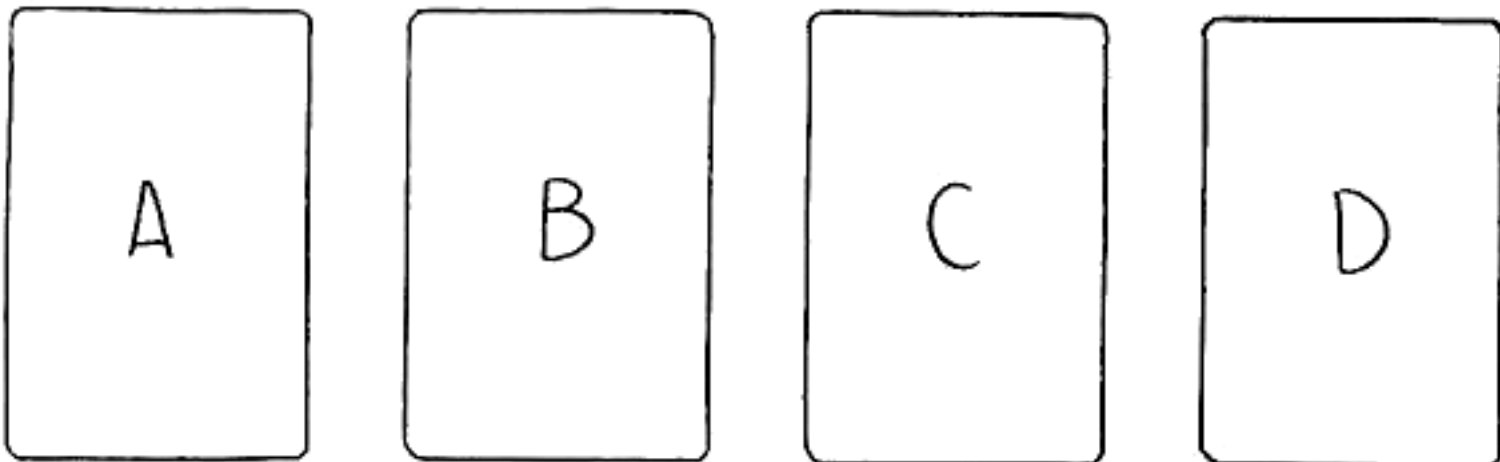


FIG. 14

1- Free Choice Force --

If you place card which you want forced in position C and have it a little nearer spectator than other cards, it is a psychological fact that he will select C in most cases.

If this force fails, you can easily remedy the situation. If spectator touches D, say, "I should have told you to select any two of the cards."

If he touches C this time, keep C and D and say you will discard the other two.

If he touches either of the other two cards, keep that one with C and discard the other two.

Now with two cards left, ask spectator to select either one. If he chooses C, discard the other one. If he chooses the other card, merely discard it with the others and retain C.

No matter what spectator chooses, he really has no choice in the matter. You use whichever card you want anyway.

2 - Force by Naming Number --

A convenient force for row of four cards. Suppose you want to force C. Ask spectator to name number BETWEEN one and four. This limits the choice to two or three. Audience rarely notices how limited the choice is, however.

If spectator chooses two, start counting at right end of cards toward left. Take C as the second card. If he says three, count from left end of cards, which makes C the third card.

3 - Force with Die --



FIG. 15

A die has six sides, numbered with one to six dots.

Figure 15.

You desire to force B or C; let us say, C. Have spectator throw die on table to select number for card. If it lights with one or four up, ask him to throw it again to prove that it is not loaded. You want two, three, five, or six to come up.

If two ones or two fours come up in succession, spectator is more than willing to throw die again to see whether it is loaded or not. If four is thrown first and then a one, or vice versa, you say four and one are five and you will take the card at number five.

This is the way you select the card:



FIG. 16

If two is thrown, count from right side.

Figure 16.



FIG. 17

If three is thrown, count from left side.

Figure 17.

If one or four are thrown, you ask for another throw.

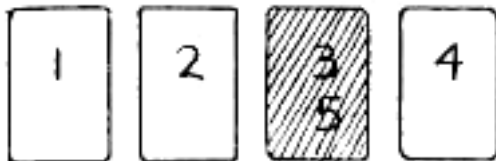


FIG. 18

If five (or four and then one) is thrown, you count from the left and back one to the right.

Figure 18.

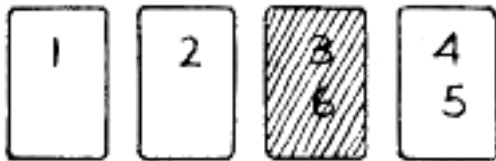


FIG. 19

If six is thrown, begin counting at left end, double count last card and then count back one to left.

Figure 19.

* * *

Forcing One of Four Cards by Using Deck --

EFFECT:

With four cards on table, performer takes rest of pack and mysteriously produces from it an ace, two, three, or

four-spot to coincide with number of card to be selected from table. This is a double force in which you force a card from the deck according to the card which you want forced from the table.

TO PERFORM:

Use any method for forcing these cards which you prefer from among those taught you in this lesson.

Slip of Paper Force --

TO PERFORM:

Take four small slips of paper. Tell audience you will write number 1, 2, 3, and 4 on each respectively. In reality, you write same number on each slip -- the number of card you want forced. If you want fourth card forced, write number 4 on each slip, etc.

Do not let anyone see what you have written. Fold each slip immediately after numbering it and throw on table. Have a slip selected by spectator and called out. Immediately crush the other slips and place them in your pocket.

If you wish to use right or left counting, you may write number 1 on two slips and number 4 on two and count according to number chosen. The same applies if you desire two or three chosen. Always pocket the three remaining slips.

* * *

FALSE COUNTING

In the effect, CARDS THAT PASS IN THE NIGHT, in a previous lesson, I taught you a method of False Counting. Here I give you other methods that will add to your fund of Magical knowledge. The effect, as you remember, is apparently to count a certain number of cards, but in reality to count fewer.

The Slip Over False Count --

TO PERFORM:

Assume that you want apparently to count TWELVE cards and really to count only NINE.

Hold deck in left hand, backs of cards to audience and faces toward yourself. Take first card with right hand and bring it upward a little and about six inches to right of deck.

(36-11)

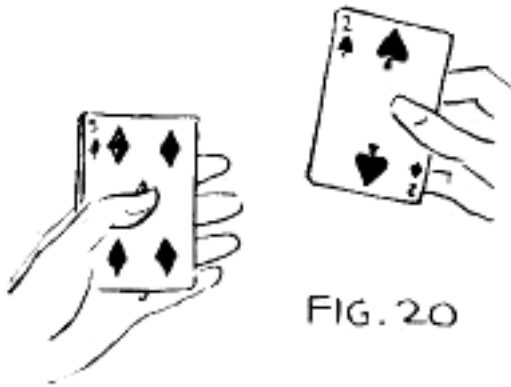


Figure 20.

Count cards aloud, saying, "One."

FIG. 20



Slide next card to right with left thumb. Place card in right hand on top of it and bring the two away together as you did the first.

Figure 21.

Count, "Two."

FIG. 21

Do the same with the third card, counting, "Three."

As you come down with right hand to pick up fourth card, slide the first card from right hand over to the left. With right and left thumbs get it back on to the deck. Remove the fourth card with the second and third.

Figure 22.

You have only three cards in right hand but say, "Four."

Count the fifth card legitimately.

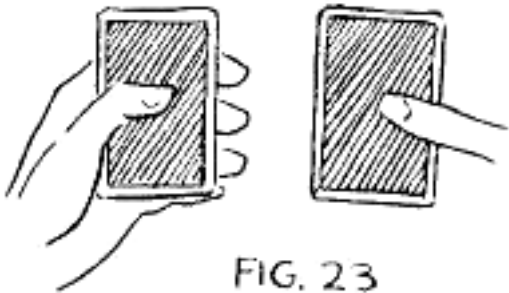
As you go along, slide two more cards back on to the deck at intervals and count the rest legitimately. Your count is then TWELVE, but you really have only NINE.

* * *

The Put Back False Count --

Suppose that you want apparently to count TWELVE cards off the deck but really to remove only FIVE.

Hold deck in left hand, backs up, in horizontal position. Or cards may be held with face of each showing as it is counted.



With left thumb slide top card half way off deck to right and take it with right hand. Count aloud -- "ONE."

Figure 23.

Push next card over to right. Place first card on top of it and remove the two with right hand. Count -- "TWO."

FIG. 23

Continue this until you have removed FIVE cards. Now take the sixth card, but keep it jogged to the left about half inch.

Figure 24.

Continue counting eleven cards, but keep all after the fifth jogged -- even with the sixth card.

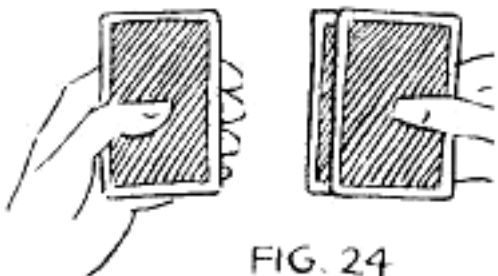


FIG. 24

When you come to the twelfth card, do not push it over with left thumb. Bring right hand with cards over to top of deck and leave the six cards, separated from first five by jog, on deck. Thus instead of removing twelfth card, you put back all except five. Bring right hand quickly away from deck as if removing another card and count -- "TWELVE."

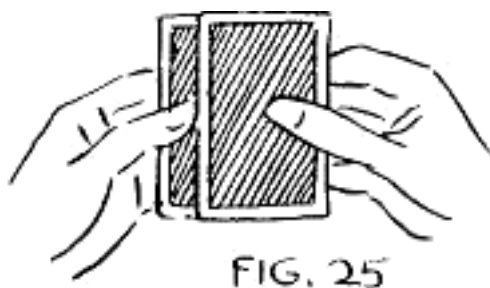


Figure 25.

Keep a uniform motion with each count. As you make the last move, keep cards turned downward a little.

* * *

The Pick Up False Count --

This is a method for actually counting MORE cards than you apparently do. Thus if you want to count TWELVE cards apparently but in reality count FIFTEEN, you may use this method.

TO PERFORM:

Hold deck in left hand, backs of cards up. Fan cards to right and get your left little finger under eight cards. Square up the deck. Now with right hand pick up the top card with fingers at outer end and thumb at edge nearest you. This view is from above.

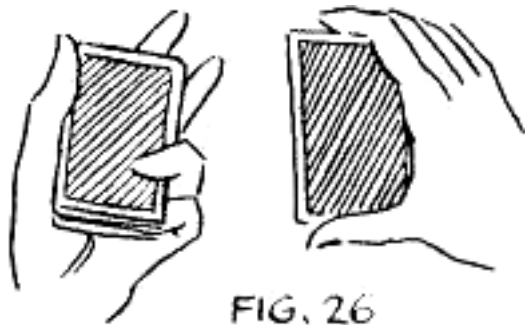


Figure 26.

Lay this card down on spectator's outstretched hand and count -- "ONE."

Pick up second card and lay it even with first on spectator's hand. Count -- "TWO." Do the same with the third and fourth, counting -- "THREE," "FOUR."

For the fifth, lift the next four cards -- those separated from deck with left little finger. Place them down on spectator's hand as one and count -- "FIVE." This gives you the three extra cards.

Continue counting until you have said "TWELVE." Spectator really holds fifteen cards in his hand.

* * *

The Palm False Count --

This is another method of counting less cards than you appear to. Assume that you count twelve cards apparently into spectator's hand, but in reality count nine.

TO PERFORM:

Hold nine cards squared up, backs of cards up, in left hand. Push off top card about half way to right. Place right hand over it and palm it.

Figure 27.

This is not an invisible palming. You do not try to conceal card in this case. Place card on a spectator's outstretched hand and count "ONE." Continue this with THREE cards.

As you pretend to remove fourth card, pull it back on to the deck with left thumb. Continue motion of hand to spectator's, pretending to place a fourth card on top of the three already there. Spectator will not be aware that you do not actually place a fourth card in his hand.

Place the fifth card down legitimately.

False count the sixth.

Place the seventh down legitimately.

False count the eighth.

Place the next four down legitimately. Count--"TWELVE."

NOTE:

After first two cards are laid down on spectator's hand, palm is not exposed to audience. They take it for granted that you have a card each time, but they cannot see it.

The "Pick Up" and "Palm" False Counts may be combined and used to begin the experiment "Cards That Pass in the Night"—or other experiments. Have spectator count 24 cards into your hand, then you False Count FIFTEEN as TWELVE into one spectator's hand and NINE as TWELVE into another spectator's hand. Thus you can cause three cards apparently to pass from one spectator to the other.

FOUR ACE EFFECTS

Effects with Four Aces have won a popular place in Magic and have become more or less of a standard classic. There are many ways of performing these effects. I shall teach you here some of the best with unprepared cards.

The Wandering Aces --

EFFECT:

Four aces are laid down in a row on the table, backs up. Three indifferent cards are placed on each ace. One of the

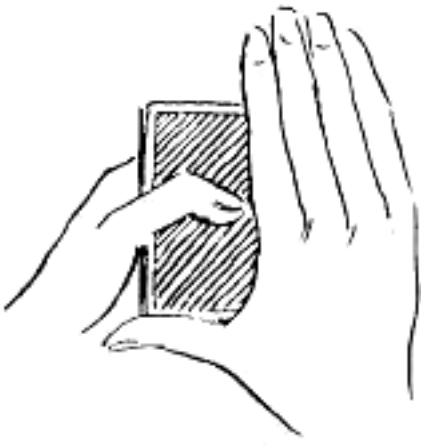


FIG. 27

four heaps is chosen, and when turned over, is found to contain all four aces. The other three heaps are shown to contain all indifferent cards.

TO PERFORM:

Run through the deck to pick out the four aces. As you find them, place them on the table in a row, backs up.

Figure 28.

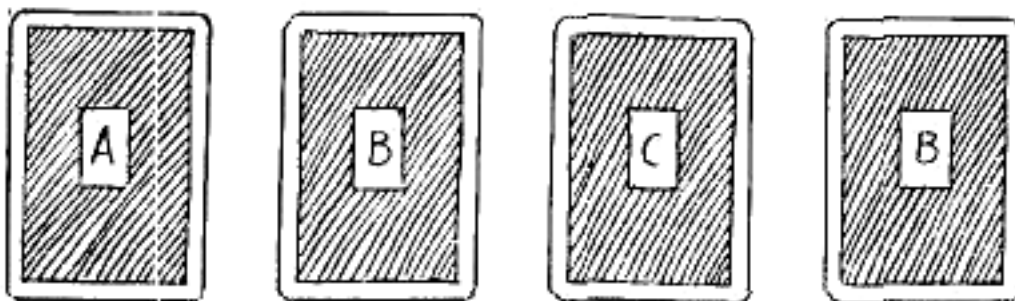


FIG. 28

"I have placed the four aces in a row on the table. But I hear some odd suspicious murmurs that the cards may not be four aces. Pick them up, sir, and make sure that all four aces are there."

As spectator looks at cards, fan deck without looking at it and get left little finger under top three cards. Square up deck.



FIG. 29

Palm off top three cards in right hand and immediately place rest of deck in right hand.

Figure 29.

"If I didn't have four aces, I really couldn't work this experiment. Now, I shall ask you to place the aces on top of the pack again."

Take deck in left hand and hold it out so that aces can be placed on top of it. Place right hand up in front of right hip, back to audience.

When aces are on top of deck, bring right hand up and place the three palmed cards on top of aces, at the same time taking rest of deck in right hand again. With left hand, point to table.

"I placed four aces on the table. The aces have been examined. I will just replace them in a row on the table again."

Lay down the top three cards in a row, backs up, about two or three inches apart. As you lay down fourth card, turn it up casually and show it to be an ace, say the Ace of Diamonds.

"The Ace of Diamonds can be on the end."

Place Ace on table to finish row.

"Now, on each ace, I shall place three indifferent cards."

Place the top three cards from deck on the end card, the Ace of Diamonds. This brings all four aces together. Do not expose cards.

"Three cards here."

Place three more cards on next card to left and expose cards a little as you place them down to show that they are indifferent cards.

"Or you can deal indifferent cards from the bottom."

Turn cards over and place three cards on each of the two remaining cards, which are presumed by the audience to be aces. Place deck aside.

"We have an ace and three indifferent cards in each one of these heaps. I shall move the heaps around a bit."

Move heaps around so that the heap of four aces comes in third position from the left and second from the right.

FORCE THE ACE HEAP by one of the methods taught you in this lesson. Place chosen heap forward a little.

Turn over heap at left end and spread.

"No aces."

Turn over heaps two and four and with each say,

"No aces."

Now turn over the selected heap and spread out.

"The heap you selected -- all aces!"

* * *

Slippery Aces --

This is one of Stanley Collins' fine effects with four aces. Mr. Collins is a well known English magician.

EFFECT:

Four aces are laid on the table in a row, faces up. Three indifferent cards are placed on each ace, faces up also. The indifferent cards are then placed in one pile and the aces in another, backs up. Performer replaces indifferent cards on deck. Cards are now dealt from the deck into four heaps of four cards each. One of the heaps is selected. The other heaps are turned over and shown to be indifferent cards. The heap of aces is turned over and that, too, contains indifferent cards. Finally the selected heap is turned over and is shown to have changed to the four aces.

(36-16)

TO PERFORM:

Place the aces in a row on the table, faces up.

Figure 30.

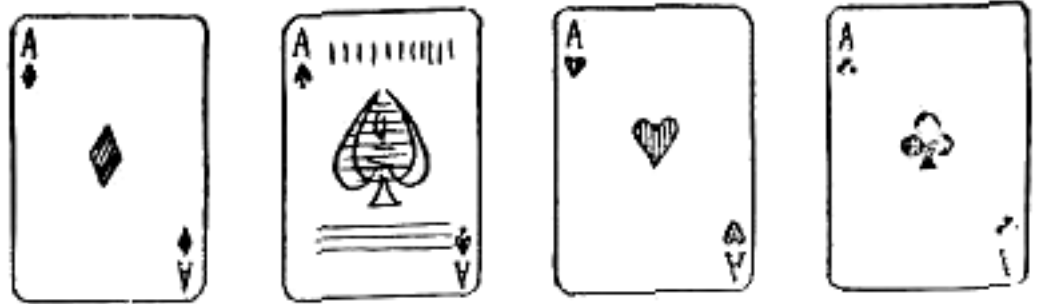


FIG. 30

"I place four aces on the table. Now I shall deal three indifferent cards down on each ace."

Now you pretend to deal three cards down on each ace, but in reality you deal FOUR cards down on each. You perform it in this manner:



FIG. 31

Hold cards in left hand with fingers on outer edge and thumb on inner edge. Cards face right. Bring right hand up to deck and place fingers behind it and thumb in front.

Figure 31.



FIG. 32

Pull down the face card in right hand, then the next card.

Figure 32.



FIG 33

Reach up with right hand to get third card and as you pull it down, also pull down the rear card. Place these two cards quickly on top of other two in right hand.

Figure 33.

The effect is that you have merely counted off three cards. Finger-tips should be moist enough to pull down rear card easily. Count cards aloud - "ONE." "TWO," "THREE."

Place the FOUR cards (presumably three) on the first Ace at the left. Continue to count off apparently three cards, but really FOUR, and place them on each of the four aces.

Figure 34.

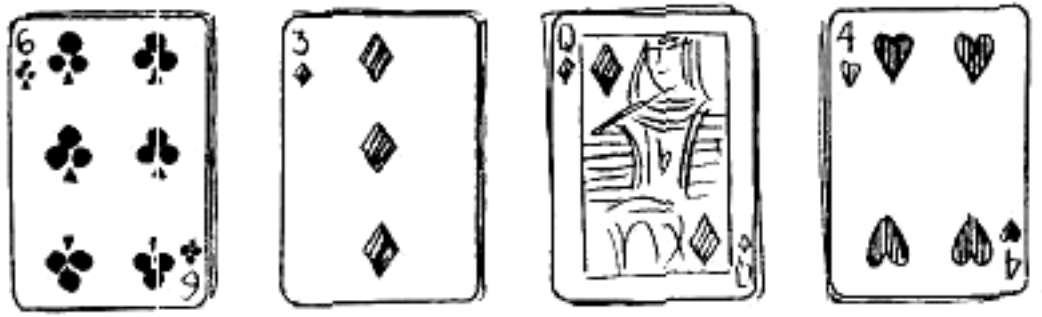


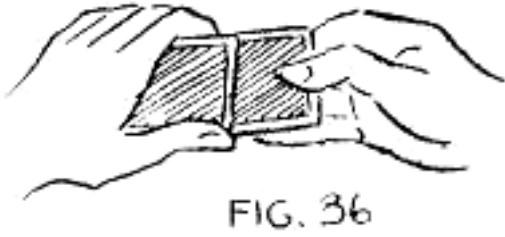
FIG. 34

Pick up left-end heap and hold in left hand, showing the face card.

(36-17)

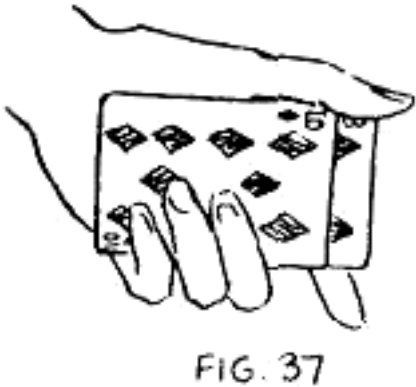


Figure 35.



Turn cards with backs up and remove bottom card with right hand. Place it on table, face up.

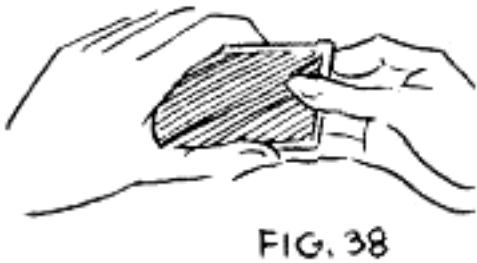
Figure 36.



The bottom card now is the extra rear card which you counted off earlier in the experiment. With second and third fingers of left hand, push it back about a half inch underneath the packet.

Figure 37 is a view from below.

Now you can easily pull out second card from bottom with right hand. Place this face up on top of first card on table. Name the card.



Reach over to left hand and take the two top cards as one. Place these down as the third card on top of other two on table. Square them up.

Figure 38.

The Ace is the second card of the two which you show as one. You name the first card which conceals the Ace. Thus you get the Ace down on the table without being detected.

You have one card left in hand, which is supposed to be the Ace.

"I shall lay the Ace over here."

Place the remaining card aside, FACE DOWN. Keep it in full view of audience all the time.

Go through same routine with heaps B, C, D. Put all of the supposedly indifferent cards in one heap. Put the four cards supposed to be Aces in another heap.

Pick up the larger heap, turn cards with backs up, and place them on top of rest of deck. The four supposed Aces remain on table.

Deal down top cards of deck, one at a time, into four heaps, backs of cards up. First lay down your row of four, then place a card on each until you have the heaps of four.

This brings all four Aces in heap C. Move heaps around and push C forward a little. Ask spectator to select a heap and FORCE HEAP C.

Turn over the other three heaps, spreading the cards to show that they are indifferent.

"Now over here at the left, we have a pile of the four Aces. At the right we have the heap which you selected. Watch! The Aces disappear from here. . ."

Turn over heap of supposed Aces and show to be indifferent cards. Do this with left hand.

"And they appear here!"

Turn over selected heap with right hand, spread cards and show them to be the Aces.

Mystic Aces --

EFFECT:

Similar to preceding effect, but done by a different method. Four Aces are placed on the table, face up. On each Ace are placed three indifferent cards, also faces up. Then each heap is picked up. The indifferent cards are placed in one heap and the four Aces in another. Magician then deals the indifferent cards into three heaps. One heap is selected. The other two are turned over and shown to contain indifferent cards. Heap of Aces is turned over and shown to contain indifferent cards also. The selected heap is then turned over and shown to contain all four Aces.

TO PERFORM:

In this effect, only sixteen cards are used, and only THREE cards are actually placed on each Ace.

Place the four Aces in a row on the table, faces up.

"I place the four Aces in a row on the table. Now on each I shall place three indifferent cards on each ace."

From bottom of deck count off one at a time, FACES UP, three cards. Place them on each Ace. Place deck aside.

Take Aces from bottom of each heap and place them on top.

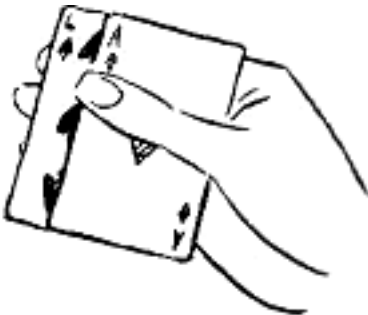


FIG. 39

Now pick up heap A and hold in right hand. Push top card out a little with fingers.

Figure 39.



FIG. 40

Push top card completely off heap in readiness for putting it down on table.

Figure 40.

Turn right hand over and lay top card down on table, back of card up.

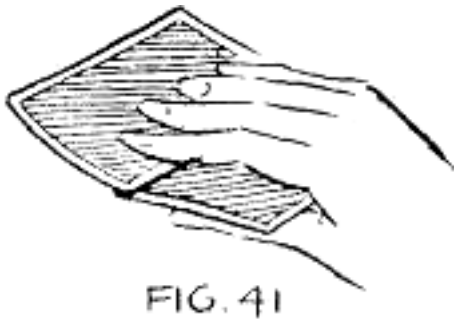


FIG. 41

Figure 41.

Show next top card in same manner. Name it as you push it off heap and place it on table, on top of first card.

Push off next top card just enough to show index. Name it.

THIS TIME WHEN HAND IS TURNED OVER AND CARD IS LAID DOWN ON TABLE, THE TOP CARD IS HELD BACK BY FINGERS AND THE ACE IS PUSHED FORWARD WITH THUMB AND PLACED ON TABLE.



FIG. 42

Figure 42.

When this move is done quickly, it is not noticeable. Audience believes that you have three indifferent cards in a heap and an Ace left in your hand.

"I will place the Ace of Diamonds over here."

Place the supposed Ace at the left.

Follow the same routine with the three other heaps, placing the supposedly indifferent cards in one heap and the supposed Aces in another.

Pick up the larger heap and deal the cards into three piles - A, B, C. This brings the Aces all into heap A. Transfer heap C over to the left so that Aces are in center heap.

FORCE THE CENTER HEAP BY FREE CHOICE METHOD. Spectator will usually select center heap. If not, use the discarding system of getting heap C as selected heap.

Turn over the remaining two heaps and show the cards to be indifferent. Turn over pile of supposed Aces and show it to contain indifferent cards. Turn over selected pile and show the four Aces in it.

Note -- If you perform the three Ace experiments one after the other, change position of Ace heaps. Start say with heap at Number Two from left. Then Number Three, etc.

* * *

RISING CARDS THROUGH THE AIR

We have discussed Rising Cards in earlier lessons, but these effects which you learn here are even more amazing than those I taught you before. Here you learn how to make cards rise up and soar into the air up into your hand. Howard Thurston made a hit in London years ago with this style of rising card effect and he still uses it in his evening performances. I give you three methods which are practical and easy to perform with or without an assistant. The effects are adapted to stage work and other work where a black thread is invisible.

Method 1 --

EFFECT:

Performer asks members in the audience to call out names of four cards. The deck is shuffled and placed in a glass tumbler on the table. Magician places his right hand high above the glass and causes one of the selected cards to rise out of the deck and soar up into the air to his finger-tips. Each of the four selected cards is made to rise in similar manner. At the end of the experiment, selected cards are thrown out to audience.

PARAPHERNALIA:

- 1 -- Two decks of cards.
- 2 -- A tray.
- 3 -- A glass tumbler with base, large enough to hold deck of cards easily.
- 4 -- A Wrist Reel. We supply you with a Reel for a reasonable price.

SECRET AND PATTERN:

To Prepare:

One deck of cards is placed, face up, on table offstage so that audience is not aware of it. Deal the cards into four or more rows so that any card can be picked up instantly.

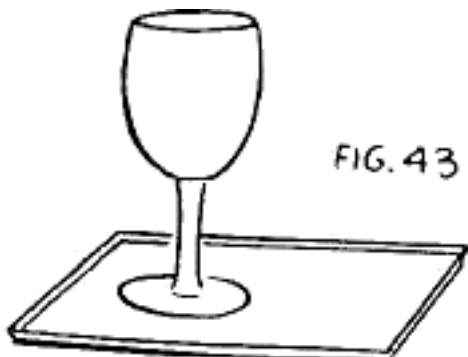


FIG. 43

Nearby have the glass tumbler on the tray. An assistant offstage has charge of this.

Figure 43.

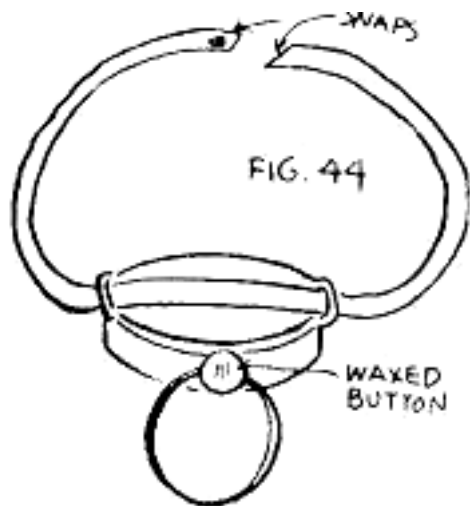


FIG. 44

The Wrist Reel is a special piece of magical apparatus. It consists of a small round box, 1 3/8 in. in diameter and 3/8 in. thick. At one side is a flesh-colored ring attached to a button, about 3/8 in. in diameter. A piece of elastic with snaps on the ends is attached to the reel. This is to go around performer's forearm.

Figure 44.

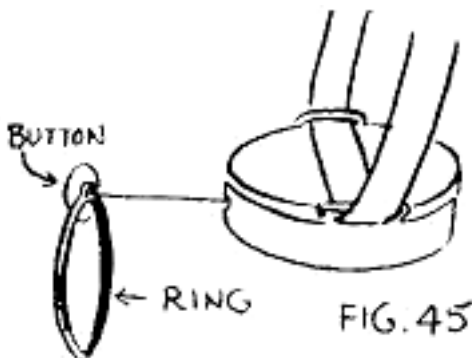


FIG. 45

Inside of the box is a wheel in which a spring is coiled and attached to a pivot. Around the wheel is wound about 30 inches of fine black silk thread. One end is attached to the wheel inside, and the other free end comes through a small hole in the side of the box. This end of thread goes through eyelet of a small flesh-colored ring and is finally tied to a small flat button. When reel is not in use, the force of the spring keeps ring and button up against the box. A piece of conjurer's wax is placed on button.

Figure 45.



FIG. 46

Fasten the Reel around your right forearm by snapping the elastic tape into place. Reel should be placed up high enough on forearm so that Ring and Box do not show. Coat sleeve is, of course, pulled down to cover Reel. It is important to be able to reach up with left hand and take hold of ring easily. You will have to experiment in adjusting apparatus.



FIG. 47

Figures 46 and 47.

As the silk thread will wear out, you must watch it closely. TEST APPARATUS BEFORE EVERY PERFORMANCE. It is easy to change thread. To do so, lift off top of box, loosen the spring at center pivot, take out wheel, and put new thread on. Then replace wheel in box, tighten spring, and replace top of box.

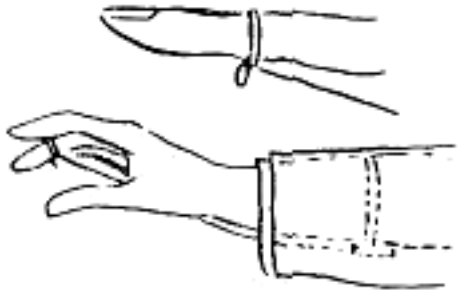


FIG. 48

Just before starting your experiment, secretly get the ring on second joint of second finger of right hand. Help adjust it with left hand. Have button toward inside of hand. If ring is too large or too small, have a jeweler adjust it.

Figure 48.

To Perform:

Have assistant offstage at the table with cards.

Come forward with second deck of cards. The Reel is adjusted to your forearm with ring on second finger.

Ask members of audience to call out four cards.

As cards are called, assistant picks up each card called for from first deck on table offstage. He places these four cards together faces up, on tray with glass tumbler. First card called goes on bottom, then second, third and fourth.

Assistant comes on to stage with tray, holding it tilted back so that audience cannot see the cards on it.

As spectators have called cards, you have named each selected card after them. Now give deck a good shuffle to give assistant time to get out on stage with tray.

Place shuffled deck, cards facing up, on top of the four cards already on tray. Pick up the glass. Assistant places tray with cards on a table on stage and exits.

Tap glass.

"This glass was once the property of an old East Indian conjurer. It is clear and has a good ring. He used to tell his audience that he used a glass tumbler in his trick so that his spectators could see through it -- that is, the tumbler, not the trick."



FIG. 49

Replace tumbler on tray and pick up deck of cards. The four selected cards are on "Top" of the deck and ready for use. Hold deck in right hand with fingers above and thumb at bottom edge. Cards face audience. Bring left hand up to deck.

Figure 49.



FIG. 50

Grasp deck in left hand with fingers in front and thumb behind. Straighten second finger of right hand so that waxed button comes near cards. With tip of left thumb push button against top card about half an inch from top edge and midway between sides.

Figure 50.

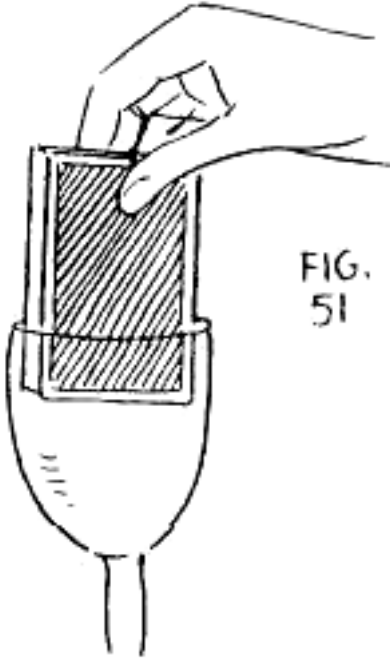


FIG. 51

Hold button secure against card with left thumb. Then put right thumb against button and hold deck in right hand over the top edge of cards. Release left hand. Place deck in glass -- cards face audience.

Figure 51.

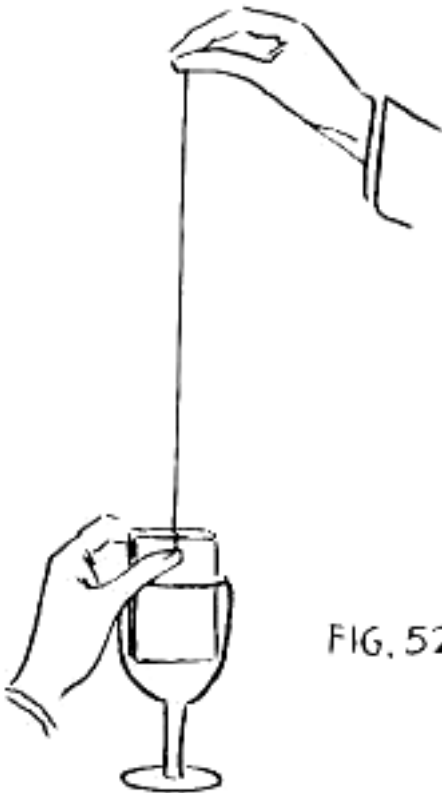


FIG. 52

Place left thumb on button again and release right hand, raising it about 18 inches above the deck. Left thumb holds button on card securely to prevent card from rising prematurely. As right hand is raised, thread is pulled out of Reel. When right hand is in position, hold thread between thumb and forefinger to prevent its winding back into Reel until you are ready.

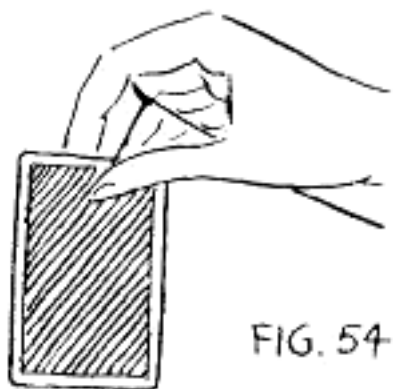
Figure 52.

Release hold on button with left thumb and bring left hand away from cards. Say to person calling out first card:

"Pardon me, what was your card, sir? The Four of Diamonds. Four of Diamonds, rise!"

Release hold on thread with right thumb and forefinger and allow card to rise up into hand. The thread winds back on to wheel in Reel and causes the card to come up to right hand. The speed with which card is to rise must be experimented with. It must be neither too slow nor too fast. Card should come up gracefully and speedily enough to keep it from turning around.

Figure 53.



When card reaches hand, grip it at upper edge -- Figure 54 shows view away from audience.

With right thumb loosen button from card and allow it to fly back against ring on second finger.

Remove deck from glass with left hand, using some suitable "Patter." Place selected card which has risen in front of deck and attach waxed button to rear card again.

Replace deck in glass, following same routine until all four selected cards have been caused to rise.

NOTE:

If desired, this experiment may be performed without an assistant. Have four spectators select cards from the deck and return them to middle of deck. Get selected cards to

"Top" of deck. As you go back to stage, you can get ring from under right coat sleeve and place it on second finger. Then proceed as above.

BE CAREFUL THAT THREAD IS NOT HELD IN FRONT OF WHITE SHIRT OR SOME LIGHT-COLORED OBJECT. It is best to have glass at the right so that your right hand is extended to the right and the thread is invisible against the background of the stage.

Method 2 --

This is the Rising Card Method which Paul Fuchs and I use. We call it our Emergency Method. It has many possibilities and does not require mechanical apparatus.

Even though we may be doing the Rising Cards with a Reel or some other method, we have a glass tumbler prepared for this Emergency Method so that it can be used if necessary. It is a good idea to be ready this way in stage work, though it is not absolutely necessary. If your thread breaks or the trick fails for some reason, you may produce the selected cards in some other way.

However, here is the Emergency Method:

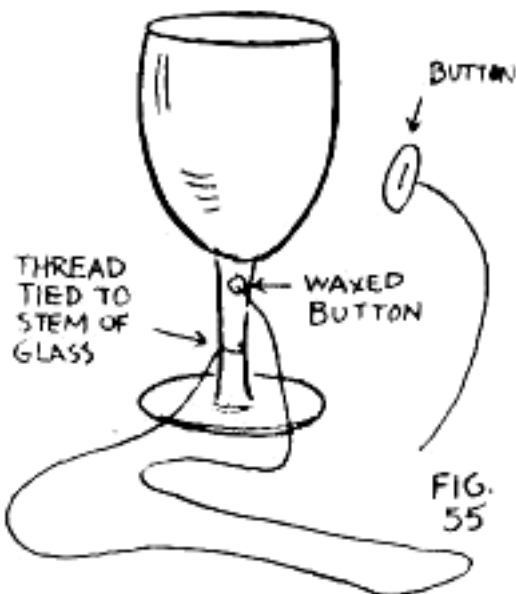
EFFECT:

Four cards are freely selected from pack, remembered, and returned to deck, which is then shuffled. Deck is placed in glass tumbler. Magician holds his hand high above the glass and the selected cards rise, one by one, up to his hand.

PARAPHERNALIA:

- 1 -- A deck of cards.
- 2 -- A glass tumbler with stem, large enough to hold deck of cards.
- 3 -- A yard of fine black silk thread.
- 4 -- A small button.
- 5 -- Conjuror's wax.

SECRET:



To Prepare:

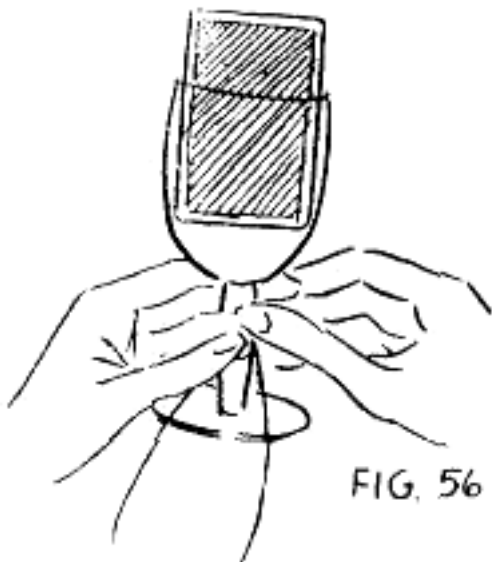
Tie one end of thread to stem of glass and the other end to a small flat button. Place a small piece of wax on button and stick button on stem of glass. Place glass thus prepared on table and you are ready to work. Turn side of glass with button away from audience. Thread is invisible.

Figure 55.

TO PERFORM:

Have four cards freely selected, remembered, and replaced one by one in middle of deck. Do the Simplified Pass and get cards to top of deck. Shuffle cards without disturbing four selected cards on top.

Return to stage. Pick up glass and show. Place cards inside of glass with faces toward audience.



Hold glass by stem in left hand. With right hand remove button from stem.

Figure 56.

Attach button to rear card of deck as you did in preceding experiment. Get right forefinger under thread and raise right hand above glass about 18 inches.

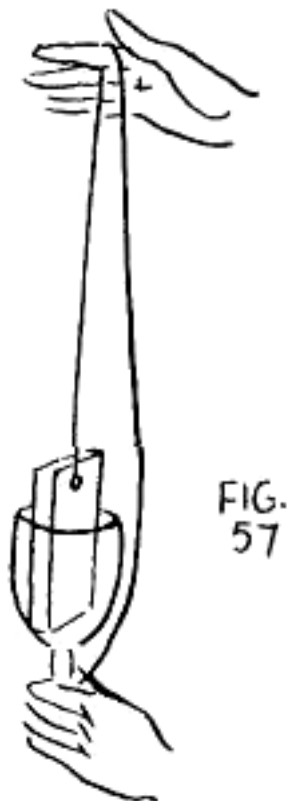


Figure 57 shows view from the side to give you diagram of arrangement of hands and thread.

Ask last spectator what card he selected. Then cause the rear card (his card) to rise out of the glass by raising your right hand and lowering your left. Card comes right up to hand.

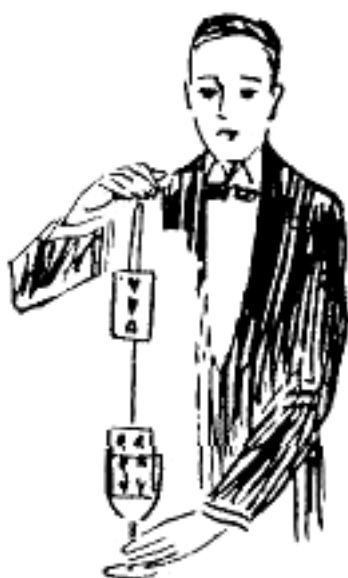


Figure 58 shows view from audience, except that thread is invisible.

Be careful to have right hand a little to the right so that thread is not in front of white shirt.

Place card in front of deck. As you do so, remove button and hold it concealed between right thumb and finger-tips. Attach button to rear card again and place deck in tumbler. Ask third spectator who selected card to name it, then cause this card to rise. Continue in this routine for all four cards.

The lowering of glass and raising of right hand slightly causes cards to rise without any apparent movement of hands.

* * *

Levitation of a Card --

A splendid climax for the Rising Cards Through the Air if you are performing on a stage and have two assistants.

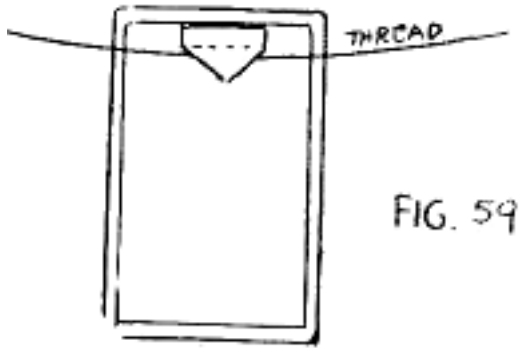
EFFECT:

Same as for Rising Cards Through the Air. Then as last selected card rises from deck and remains suspended in air,

(36-25)

performer passes his hands around card to show no connection. At command, card rises and drops and finally drops almost to the floor. Then it comes up again to performer's hand.

SECRET:



To Prepare:

This effect requires a prepared card. Cut a piece from a card, straight at one edge and triangular at the other. Crease triangular end a little and paste straight edge down on back of another card at top. This makes a lip under which thread can be stretched.

Figure 59.

Place this prepared card in a pocket which you can reach easily.

Stretch a fine black silk thread across the stage. Have each end held by an assistant in opposite wings offstage. Before performing effect, put thread out of the way by tying it in SLIP KNOT fashion over a nail high up on each side of stage.

To Perform:

In having cards selected FORCE A DUPLICATE OF THIS PREPARED CARD AS THE FIRST SELECTED CARD. After you have had four selected cards returned to deck and have performed the Simplified Pass, this duplicate card is fourth from top of deck and is out of the way. As you go back to stage, get the prepared card and place it on top of deck. Or have assistant place prepared card on tray and you place rest of deck on it as taught to you in a preceding experiment.

In this case, place button on NEXT to top card to cause three selected cards to rise. After three cards have risen, the prepared card is next. This is on top of the deck.

Take cards out of the glass and hold in left hand, cards facing audience. Fingers are in front and thumb behind cards. Hold deck about a foot in front of you.

At this point, have assistants pull on thread enough to slip knots from nails and bring it down in front of you and back of deck so that you can easily hook prepared card on it. Raise right hand a little, apparently causing card to rise as assistants raise thread. Drop left hand with cards to your side.



Figure 60.

At command, card is caused to rise and drop at different rates of speed. At intervals you can pass hands above, below and around card to show no connections. When you pass hands over sides of cards, do it behind thread. It looks as though you pass hands directly beside edges of cards.

(36-26)

Finally have card drop down almost to floor, and then quickly rise up to hand.

Figure 61.

Catch card in right hand and hold as one assistant drops thread and other assistant pulls it clear of card and offstage.

With good SHOWMANSHIP, you can get a wonderful effect with this.

* * *

CARD FOUNTAINS

This makes a beautiful effect with cards and adds display to your program with little effort.

EFFECT:

Three cards are selected and shuffled back into deck. Deck is placed in a glass tumbler, which is placed on the seat of a chair. At command, the cards start flying out of the glass, way up into the air. They continue to fly out until only the selected cards remain in the glass. These are then removed from tumbler and shown.

Method 1 --

This Method is the one used by DeKolta, one of the finest magicians of days gone by.

To Prepare:

Take a spool of fine black silk thread and start unwinding it. Wrap the end of the thread twice around a card.

Figure 62.

In front of this wrapped card, place three cards. When you perform the experiment you FORCE duplicates of these three cards as selected cards. Remember these three cards for forcing later.

Figure 63.

Now you proceed to thread rest of deck. Thread is wrapped around starting card. Now bring it back of card and down. Place another card BACK of starting card and bring thread up around this card, across top edges of the other cards you have placed together, and then down in front of selected cards. Place a card in front of selected cards and bring thread up around this card. Now carry thread over tops of cards again and down in back. Place card behind rest of cards again and bring thread up around it, over tops of cards

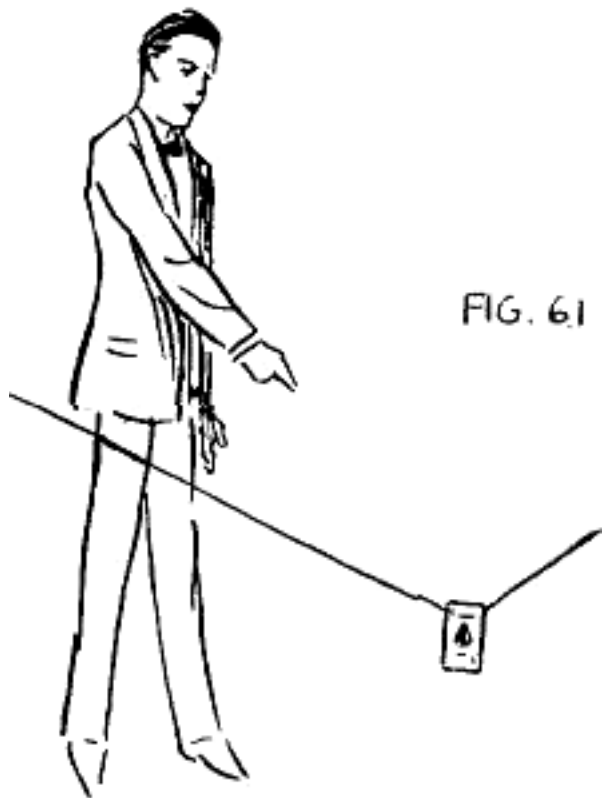


FIG. 61

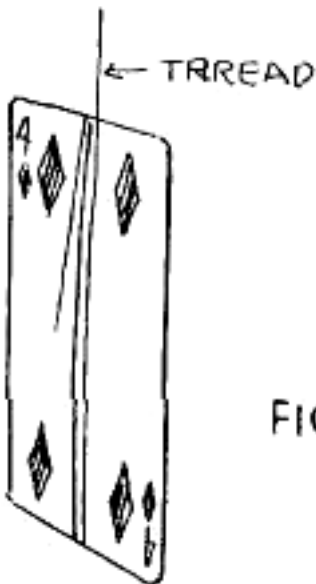


FIG. 62



FIG. 63

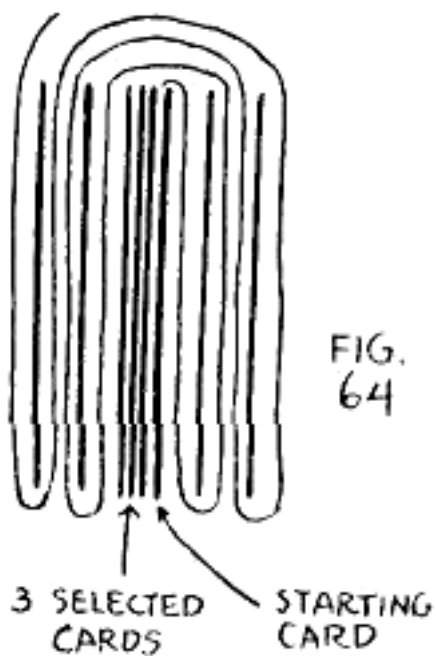


FIG.
64

and down in front of bunch of cards again. Place another card in front and bring thread up around it again. Proceed in this manner to thread the whole deck.

Figure 64.

When deck is completely threaded, bring thread down around whole deck and up in back.



FIG.
65

Figure 65 shows the threaded deck as it looks when finished.

Place threaded deck on seat of a chair and run thread up over back of chair and out backstage, where it is secured on a nail in the wall. Assistant can thus get end of thread when time comes for him to pull on it.

Place a silk or pocket handkerchief in front of deck on chair to conceal it.

Have a glass tumbler on chair also.

TO PERFORM:

Pick up another deck, unprepared. Come down to audience and FORCE duplicates of the three cards already placed in center of prepared deck, unthreaded. Have these selected cards well shuffled into deck.

Come back to stage and place this deck next to threaded one behind handkerchief. Pick up glass tumbler and show it, then replace on seat of chair again. Pick up threaded deck as if it were an ordinary one and place it in glass.

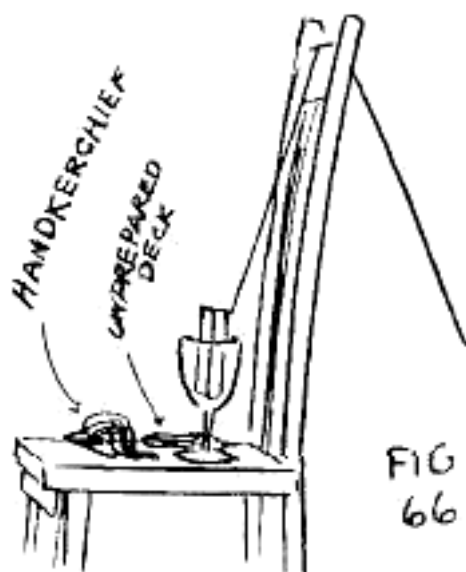


FIG
66

Figure 66.

At command, assistant pulls thread fast. All the cards fly out of the glass high into the air, except the three unthreaded ones.

Figure 67.

The three selected cards are picked up and shown separately. Call out the name of each.

A little practice will be necessary to get the hang of throwing cards high into the air, but when you have it mastered, you will be well repaid in having a beautiful effect.

NOTE:

In this method it is necessary for the thread to be pulled vertically. That is the reason the thread is run over the top of the chair.

(36-28)



FIG.
67

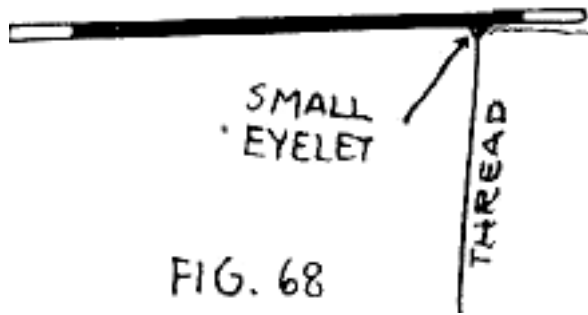


FIG. 68

Another ruse which may be used in this one: Screw a small eyelet near end of your wand. Run end of thread from deck of cards through eyelet and out backstage to assistant.

Figure 68.



FIG. 69

Glass, deck, and wand may be resting on a table with handkerchief screening threaded deck as before. When threaded deck is placed in glass, you have but to raise your wand above deck. Assistant pulls thread and cards fly out. Your wand keeps thread vertical above deck.

Figure 69.

* * *

Method 2 --

This method is popular. It requires no vertical pull. A strong pull is required, however, and for that reason it is necessary to clamp glass down on table and table must be heavy enough not to tip easily.

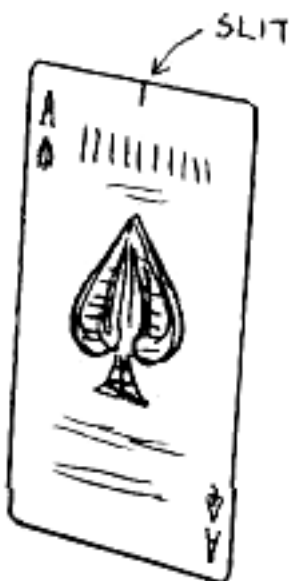


FIG 70

TO PREPARE:

Take each card of deck and cut a quarter of an inch slit in middle of top edge.

Figure 70.

Make knot in end of black silk thread and run thread through slit from front to back of first card.

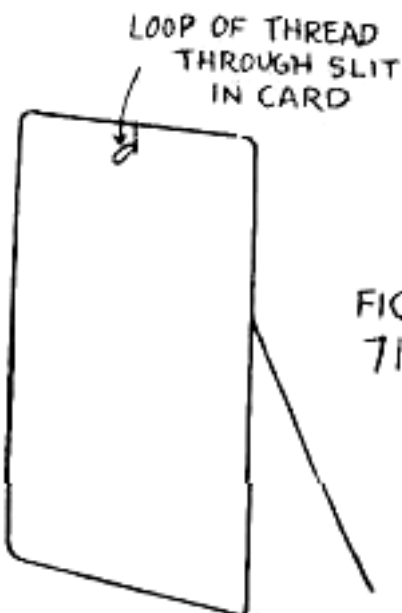
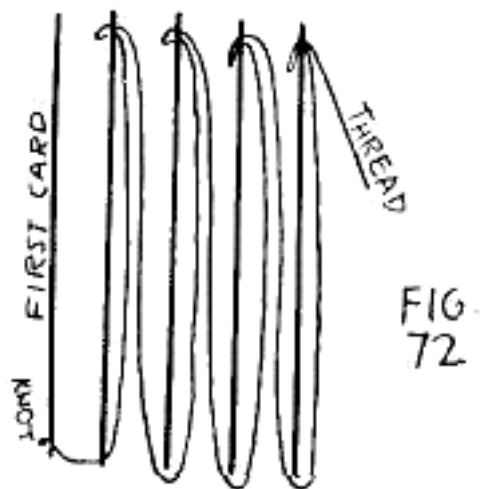


FIG 71

Turn card upside down and back of it place another card with slit end up. Bring thread up behind card. Push it through slit and back again, leaving a half-inch loop on front of card.

Figure 71.



Now bring thread down again. Place another card back of it and bring thread up around it and loop through top slit as before. Continue this until you have the whole deck threaded except for 3 cards. The first card is the only one with the slit end down. The rest are all up with the thread looped through.

Figure 72.

Place three selected cards, duplicates of which you are going to force, on back of deck. Place deck on table with handkerchief screening it. Run thread back over table, through a screw eye at the edge, and out to assistant backstage.

(36-29)

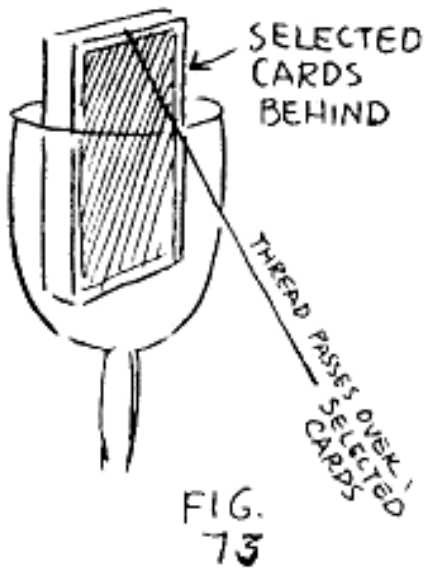


Figure 73.

To secure glass to table, use a clamp of wood or metal. The clamp is of two sections. Have them screwed to table the width of the glass stem apart. Have screws at front end and arranged so that the two sections can be swung out. At the back end have a strong hook and eye arrangement for securing two sections of the clamp.

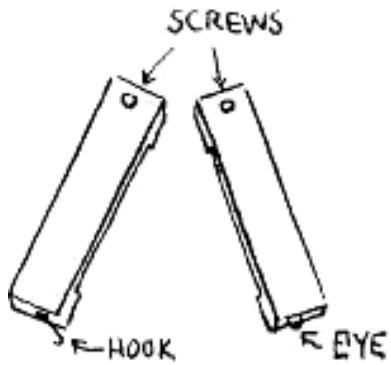


Figure 74.

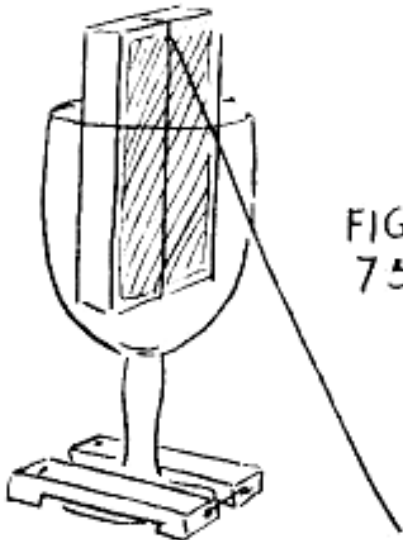


Figure 75 shows glass held in clamp on table. Glass is put between sections and clamp is fastened together.

TO PERFORM:

Take regular deck and force three cards, duplicates of three unthreaded cards in prepared deck. Have cards returned and shuffled into deck. Place it on table behind handkerchief. Show glass and clamp it to table. Pick up threaded deck and place in glass. Upon command cards fly from glass, leaving the three selected ones.

This Card Fountain makes a fine finish to a card act.

Harlan Tarbell

TARBELL SYSTEM, INCORPORATED, Chicago.

LESSON 37

A very novel lesson, teaching you most interesting effects in Oriental Magic. Something new and different for you.

* * *

ORIENTAL MAGIC

From time immemorial tales have come out of the Far East about the weird mysteries of the Orientals. Writers and artists have woven strange stories and have drawn fascinating pictures of Oriental Magic. Because of this, the public has come to believe that mysteries of the Orient have an unusual charm.

In reality, the Oriental Magician is no more clever than the Occidental Magician. But because the Oriental comes from a distant, strange land, his appeal is greater. The Oriental has had good publicity and you can gain by it. Put Oriental mysteries into your programs and you can profit by the appeal of the Oriental.

In favor of Oriental presentation of Magic is the chance to use odd lighting effects, beautiful costumes, mysterious designs, etc. There is no end to stage effects which you can secure in presenting Oriental Magic.

The Magic need not necessarily be of Oriental origin, but can be presented in that manner. You can take modern American or European effects and build them up in Oriental style. Oriental Magic can be presented in special costume or in modern day dress. Sometimes just a bit of costuming or scenic effect or a few painted decorations give the desired effect. And in Magic, the EFFECT is the important thing.

Give any ordinary experiment the proper atmosphere to awaken the imaginations of your spectators and you make that experiment a wonderfully effective thing. Oriental technique can sometimes make a sensation of even a commonplace magical effect. The secret of it all is SHOWMANSHIP—and Oriental Magic gives you a wonderful opportunity for most effective showmanship.

In preceding lessons I have given you some interesting effects which can be presented with Oriental technique. In this lesson, I teach you some real Oriental Magic--that is, Magic which is of Oriental origin--Magic from China, Japan, India, Egypt, Persia. Study this lesson well and I know you will profit by it in reputation and finances.

* * * * *

CHINESE COLOR-CHANGING COINS

EFFECT:

Performer shows sixteen gold coins. Upon command, they mysteriously change to silver coins, and finally to a variety of colors.

PARAPHERNALIA:

1--Sixteen Chinese Coins.

If you cannot secure Chinese Coins, you may use palming coins, pennies, nickels, or even round pieces of cardboard. The small round price tags with metal edges are fine for this effect also. These may be secured at stationery stores.

SECRET AND PATTERN:

To Prepare:

Start with sixteen coins. Four are left unprepared. The other twelve are prepared on ONE side.

Paint seven of the coins on ONE side with gold paint, leaving a margin around the edge of about a thirty-secondth of an inch or more.

Paint one coin red on one side, another green, another blue, and another black.

Divide one side of the remaining coin into four sections and paint the sections red, green, blue, black, respectively.

When the coins are stacked together, the edges show silver regardless of what color the surfaces are painted.

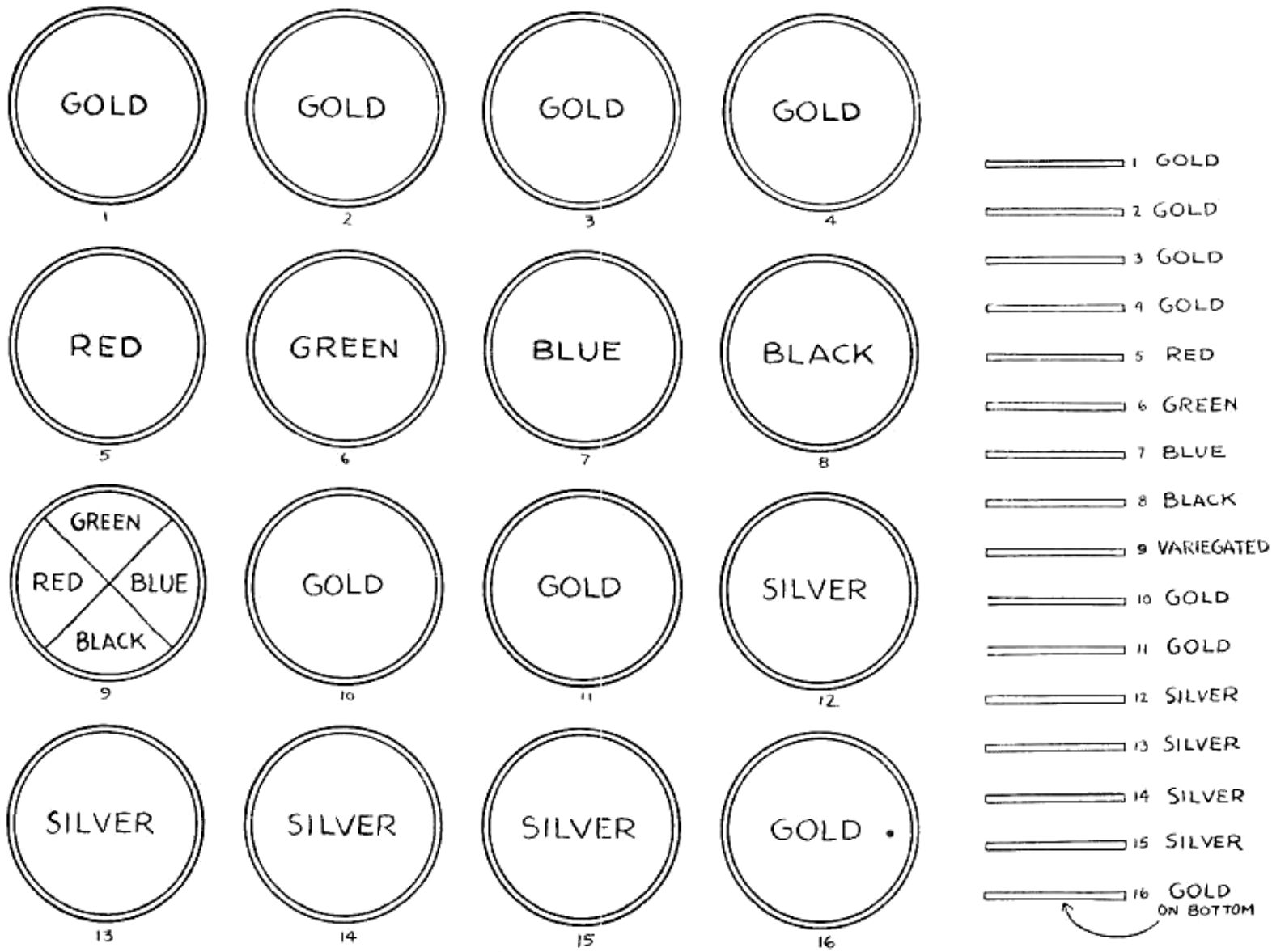


FIG. 1

FIG. 2

If you are using price tags or cardboard disks, you may paint the surfaces to make the silver ones with aluminum water color or leave them white, as you desire.

When the coins are prepared, lay them down on the table, four in a row in order shown in Figure 1. The bottoms of all the coins are silver. Now stack the coins with No. 1 at the top and No. 16 at the bottom, picking them up one on top of the other from left to right. Turn the bottom coin over so that gold side is at bottom. Memorize the order of the coins so that you will remember them and can stack them quickly in the right order—four gold ones on top, then four colored ones, the variegated one, two gold coins, four silver coins, and a gold coin upside down on the bottom. To help you remember the order, group the coins by the number of each color, thus: 4-4-1-2-4-1.

Figure 1 shows the order in which to lay the coins down before stacking them.

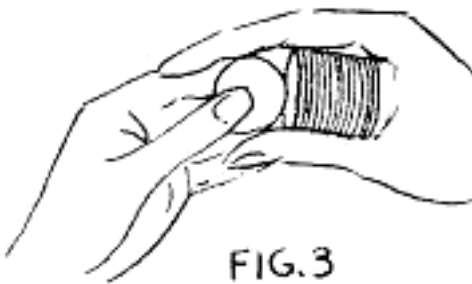
Figure 2 shows order of coins as stacked.

Carry stacked coins in a small purse so that they will not be disarranged in carrying.

To Perform:

Come forward and show coins stacked with top of No. 1 toward audience.

"This is an odd Chinese coin experiment. I am going to perform it just as the Magician does in China and so I shall use sixteen gold coins."



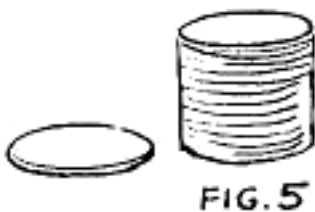
Show both ends of stack of coins, gold on each end. Place stack in right hand between thumb and fingers with No. 1 toward crotch of thumb. Under cover of right hand, which now completely screens coins, secretly reverse bottom coin with left hand so that silver side now faces bottom.

Figure 3.



Without exposing bottom of stack, place coins on table.

Figure 4.

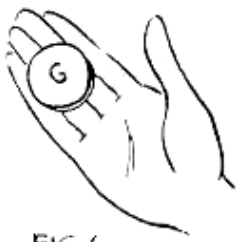


Slide fifteen of the coins to the right, leaving bottom coin apart on table.

Figure 5.

Audience now sees top of bottom coin to be gold. You have apparently shown both sides of this coin, but really have shown only one side. Now place this coin on top of stack.

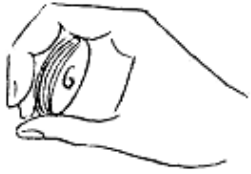
Your movements now are done in a rather free and easy manner, as if merely to show that coins are gold.



With left hand remove the four top coins, one at a time, and place each on right fingers, gold side up.

Figure 6.

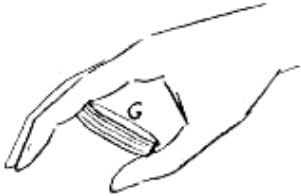
FIG.6



Now you pretend to show other side of coins. Curve fingers inward and bring thumb up against edges of coins.

Figure 7.

FIG.7



With aid of right thumb bring coins into position shown in Figure 8 and show top surface--G--again. To the audience it appears that you have turned coins over, but in reality you merely turned hand and changed position of coins to give that illusion. Be careful to keep under surface of coins concealed.

FIG.8



Spread coins out on table, overlapping each other, with gold surfaces up.

Figure 9.

"Just gold coins. A little gold now and then is relished by the best of men."

FIG 9



Gather up the four coins and place them on the stack again. Pick up stack in left hand.

Figure 10.

Place coins in right hand. Be careful not to expose the silver side of bottom coin as you place bottom of stack against crotch of right thumb. Under cover of right hand, reverse top gold coin with left hand.

FIG 10

"Chinese money is peculiar sometimes. It seems to change value. You never know how much it is going to be worth. You might have a million yen and yet be worth only thirty-nine cents. Sometimes you start with gold money, and suddenly find that it has changed to silver."

Show top and bottom of stack of coins by transferring from hand to hand. Replace coins in right hand again and reverse outer coin again as in Figure 3. Place stack on table again as in Figure 4, silver sides of all up.



With right hand, spread coins out in a row on table to show that they have all turned to silver.

Figures 11 and 12.

FIG.11

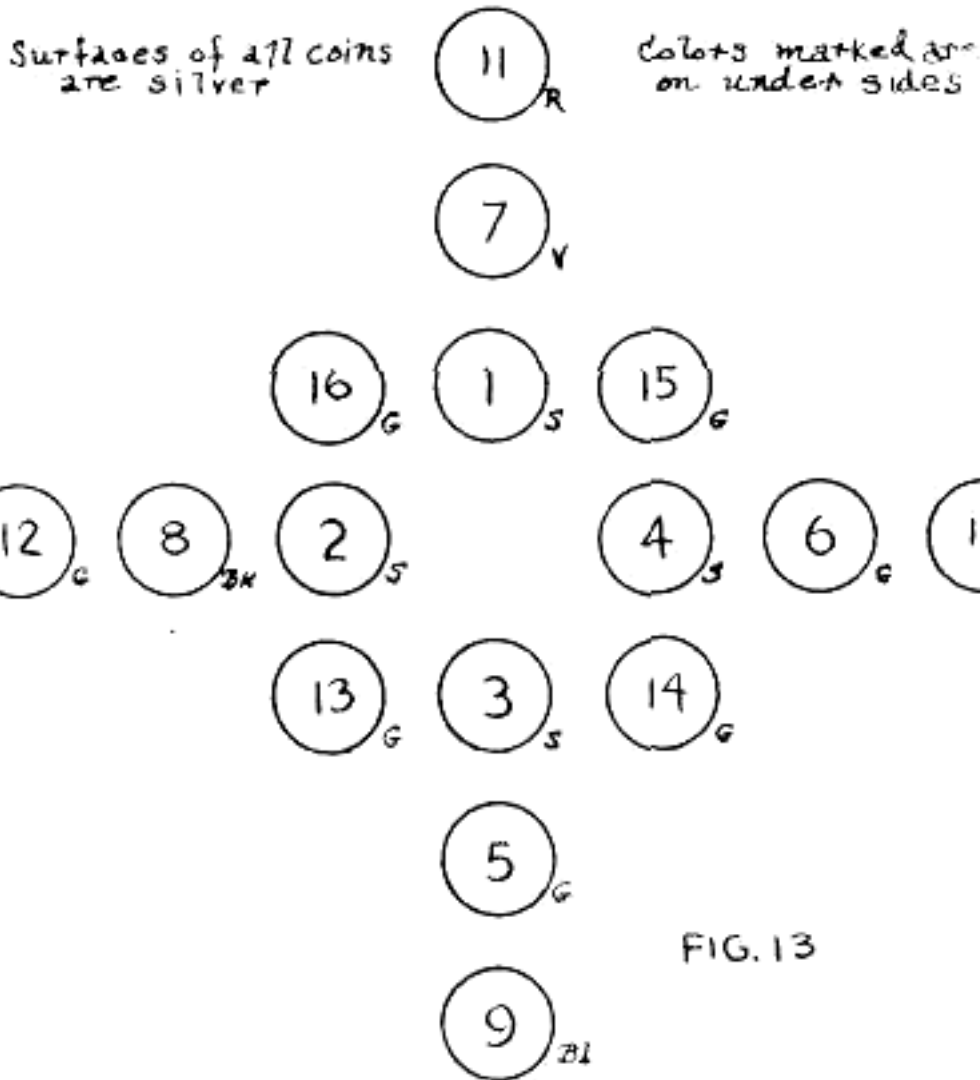


FIG 12

"All silver!"

Bring coins up with stack again, being careful not to change order of coins.

"The Chinese have a peculiar system of counting money, too."



Starting with top coin of stack, lay the coins down one at a time in the order shown in Figure 13. Silver surfaces are up. Count each coin as you lay it down to form the figure shown in the diagram. Colors on diagram are for colors of bottom of coins to help you in checking up until you have mastered the trick.

Pick up No. 5, place it on 9, then both on 14, and all three on 3. As you pick up coins count—One - Two - Three - Four. In an offhand manner, show both sides of stack of four coins. This convinces audience that coins are silver on both sides.

FIG. 13



FIG. 14

Place coins in position A as shown in Figure 14.

Go through same routine with rest of coins, showing both sides of each stack as you pick it up.

Pick up No. 6-10-15-4. Place at position B.

Pick up No. 7-11-16-1. Place at position C.

Pick up No. 8-12-13-2. Place at position D.

"Here is another way that the Chinese count coins."

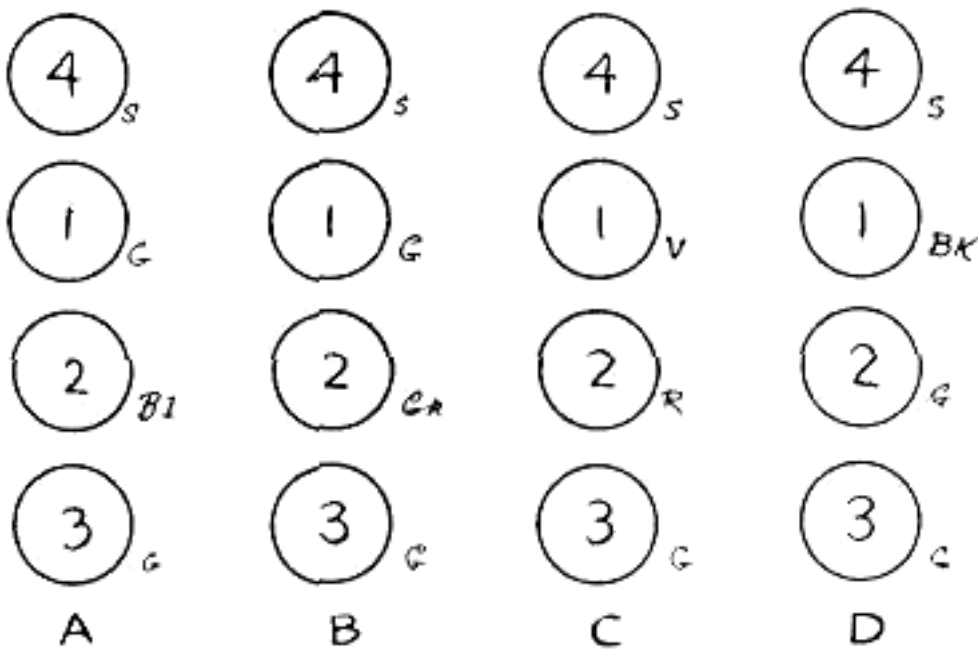


FIG. 15

Pick up stack A. Start with top coin and place the four coins in a row as shown above letter A in Figure 15. The first three coins are placed under each other and the fourth is placed above the first. Lay out stacks B, C, D in similar manner.

Colors on diagram show position of colors on bottom of coins. Upper surfaces are all silver.

Now pick up the top row of coins from left to right, placing 4A on 4B, etc. Place this stack of four coins in position E as shown in Figure 16.

Pick up the other three rows the same way and place them in

stacks—F, G, H, respectively.

Place stack G on H, F on top of these two, and finally E on top of all the coins, giving you a stack of sixteen coins again.

Pick up stack with left hand and place in right hand. Be very careful not to expose gold coin on bottom of stack which goes against crotch of right thumb.



FIG. 16

"From an old Chinese Magician I learned that if gold coins changed to silver, the same principle could be applied to change silver coins to gold."

Place stack on table, gold surface of bottom coin uppermost.

"So we have gold again."

Lift up the four top coins, one at a time, and place them on right hand. Pretend to turn them over to show other side of stack and then spread them out on table. See Figures 6, 7, 8, 9.

"Another peculiarity about Chinese money is that if you touch a color....."

Touch something red--anything which happens to be around, or place something in the colors you need nearby before you begin, or point to an imaginary color in the air.

"For instance, red--and then touch the coins....."

Lift off top gold coin and place on table, exposing the red coin on top of stack.

"A coin will mysteriously change to the same color. I touch another color--say, green."

Touch a green object. Lift off red coin and place on table, exposing green coin. Reach up and touch a blue object.

"Now a little blue."

Lift off green coin and show blue one.

"The wind blew (blue) this one."

Touch a black object.

"A bit of black."

Lift off blue coin and expose black one.

"Night-time in China! If I wish, I can touch many colors."

With right fingertip touch each of the colored coins. Then lift off black coin and show the variegated one.

"This one is like Joseph's coat of many colors."

Lift off variegated one.

"So, we have gold coins again."

Lift top coin up about three inches to expose gold coin under it and drop coin again.

"Strange people these Chinese!"

Stack coins and place in pocket.

CHINK-A-CHINK

EFFECT:

Performer places four small Chinese weights about a foot apart in a square. He covers one of the weights for an instant with one hand and places his other hand over an empty space a little farther away. Mysteriously the weight jumps from under Magician's hand to the space under his empty hand. This is done with each of the weights.

PARAPHERNALIA:

This effect was originally performed by pure Sleight of Hand. The Magician appeared to use four weights, but in reality used five. The fifth weight was obtained secretly and palmed.

Max Malini, a prominent society Magician, does Chink-A-Chink with cubes of sugar.

Jack Davis has brought out a set of Chink-A-Chink weights which does away with the palming of the extra weight. The set includes a shell which looks like a regular weight.

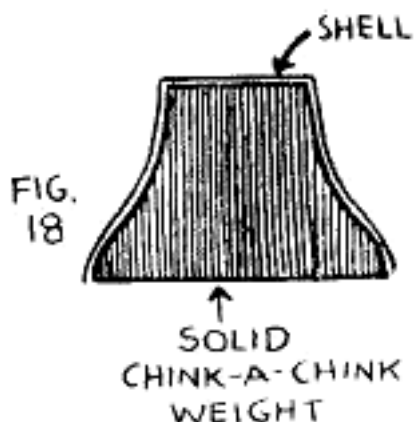


Figure 17 shows the shape of a Chink-A-Chink brass weight. Figure 18 shows how the shell covers a weight.

We can supply you with a Chink-A-Chink outfit at a reasonable price.

SECRET AND FATTER:

To Perform:



Place the four weights on table in the form of a square, the weights about a foot apart. Have shell covering No. 4 at lower right-hand side of square.

Figure 19.

Place left fingers over 3 and right fingers over shell at 4. Keep fingers close together and cup hands, bringing thumb down against weight. Hands must be in such position as to make it easy to pick up weight with pressure between thumb and third finger.



SHELL
COVERS
NO. 4



FIG. 19



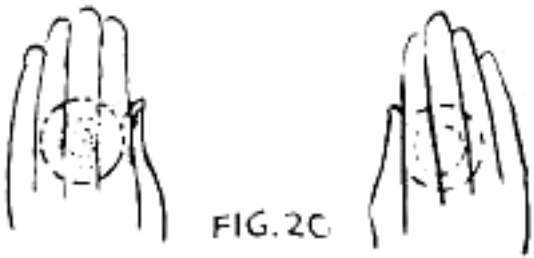


Figure 20.

As you cover 3 and 4, say:

"Chink-A-Chink."

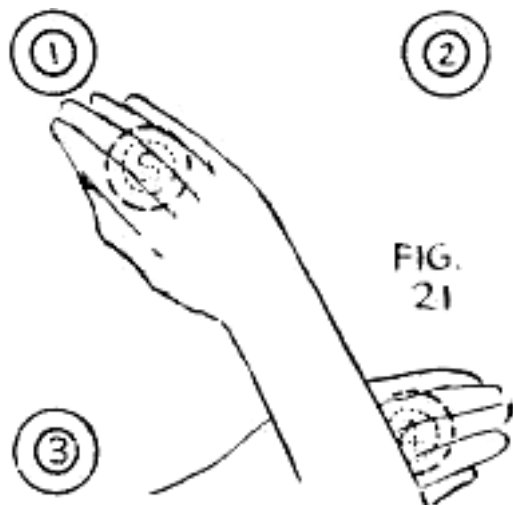
(37-7)

Remove hands and cover 1 with left hand and 2 with right.

"Chink-A-Chink."

Remove hands and cover 3 and 4 again.

"Chink-A-Chink."



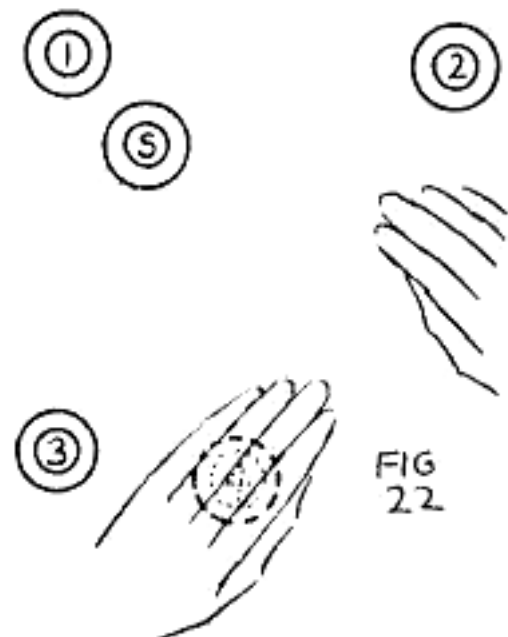
With right hand secretly pick up shell from 4. Lift hands, showing all four weights still on table. This is important. Then bring empty left hand over 4 and right hand with concealed shell over left wrist up near 1.

Figure 21.

When hands are in position, say:

"Chink-A-Chink."

Raise right hand, leaving shell on table near 1. Secretly Palm weight 4 in left hand and raise hand to show empty space. No. 4 has apparently jumped up near No. 1.

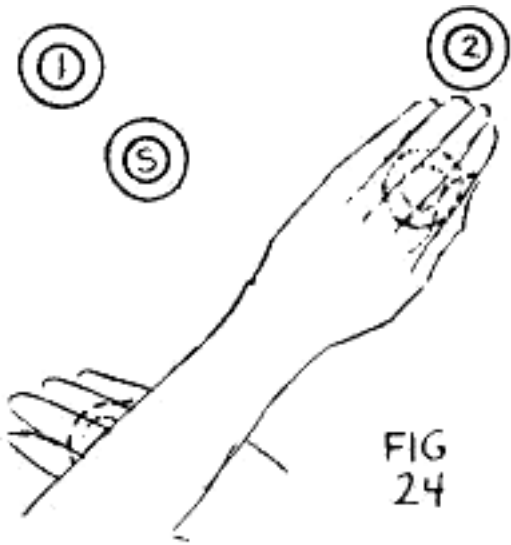


Weights are now in position shown in Figure 22.



Figure 23 shows performer and weights at this stage of experiment as audience sees them. Performer's hands are raised up high enough to show changed position of weights to audience. Weight 4 is palmed in left hand and the shell has moved up near 1.





Cover 3 with right hand. Bring left arm over right wrist up near 2.

Figure 24.

FIG 24



"Chink-A-Chink."

Raise both hands, showing that the lower left-hand weight has jumped over near 2. Weights are now in positions shown in Figure 25.

(37-8)

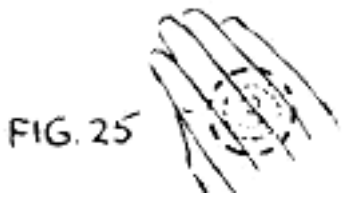


FIG. 25

"Chink-A-Chink."

Place right hand at lower left-hand position and left crossed over right wrist and over No. 2. This position is similar to that in Figure 24, except that left hand is over 2.

Leave weight from right hand at position 3 and Palm No. 2 in left hand. Raise hands to show that 2 has apparently jumped down to 3.

Bring left hand with Palmed weight to lower right-hand corner and cross right arm over, placing right hand on shell near 1.

"Chink-A-Chink."

Palm shell in right hand. Lift both hands to show that weight has jumped down to lower right-hand corner. The four weights are back to their first positions in square formation. The shell is palmed in right hand.



To dispose of shell place right hand over No. 4, covering weight with shell, and left hand over No. 1.

Figure 26.

SHELL
COVERS
NO. 4

"No Chink-A-Chink."

Lift hands and show weights. You may then pick up weights and shell and place in pocket. Or if you wish to allow audience to examine weights, Palm off shell as you place the four weights in a row for examination. Dispose of shell in pocket.



FIG. 26



Figure 27.

FIG. 27

* * * * *

THE PHANTOM KNOT

A pretty effect with a piece of soft clothesline.

EFFECT:

Performer ties a single knot in a piece of clothesline. He merely passes his hand over the knot and it disappears.

PARAPHERNALIA:

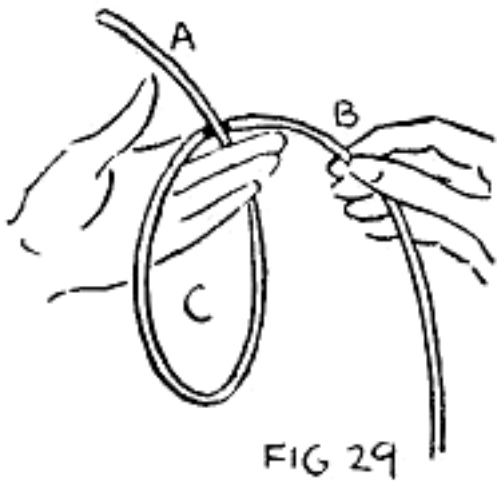
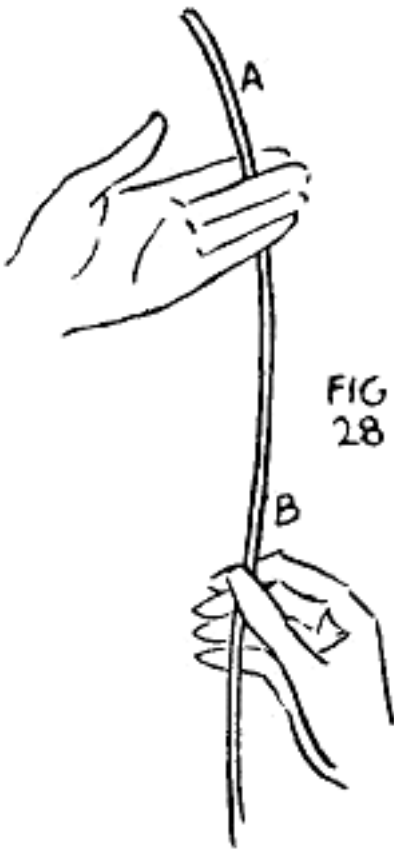
1--A piece of soft clothesline, about 3 feet long.

MODUS OPERANDI:

Hold rope between first and second fingers of left hand about five inches from one end. Grasp rope between first

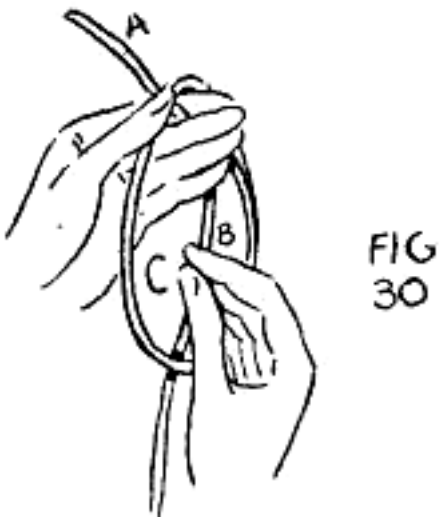
finger and thumb of right hand about same distance from other end.

Figure 28.



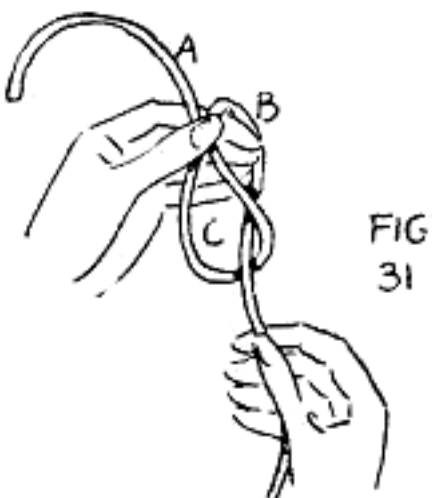
With right hand bring end B up BEHIND end A. making loop C.

Figure 29.



Slip end B through loop C from the back to the front.

Figure 30.



Pull end B down to make a loose single knot. The tie appears to be a knot to the audience, but in reality it is a fake knot. A real knot would be tied by placing end B in front of end A. In this case you put end B in back of A, and the result is there is no knot.

Figure 31.



FIG
32

To tighten knot a little, pull up on end A. Be careful to cover point where A and B cross each other with thumb and fingers of left hand to prevent detection of fake knot by

audience.

Figure 32.

Pull down on end B again with right hand and slip left fingers out of loop.

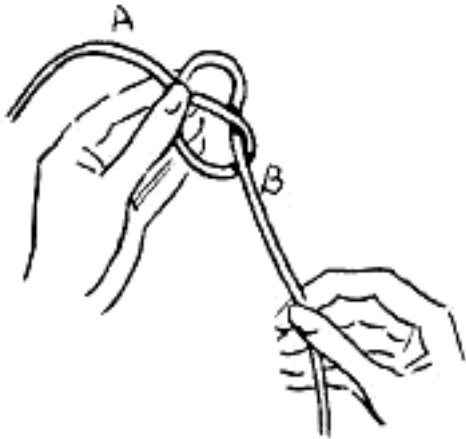


FIG.
33

This gives audience a good opportunity to see knot.

Figure 33.

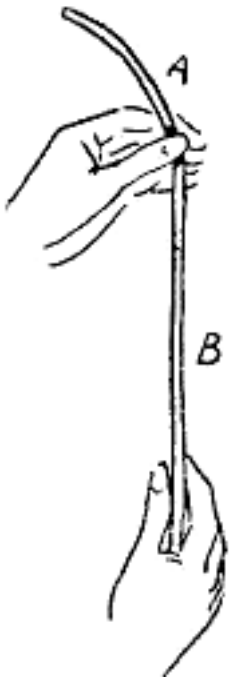
(37-10)



Every move has been made slowly and deliberately and audience believes that they have seen you make a real knot. Now bring right hand around knot and slowly move hand downward.

Figure 34.

FIG 34



This causes fake knot to untie and rope hangs straight between your hands.

Figure 35.

FIG 35



Remove right hand from rope before you reach lower end and show right hand empty to prove that you have not slipped knot from end of rope. Let rope hang from left hand and show to audience.

Figure 36.

* * * * *

THE MYSTIC KNOTS

This effect may be presented in any kind of Oriental program to good advantage.

FIG 36

EFFECT:

Performer shows a piece of soft, white clothesline about eight feet long. He coils this up in his left hand and places rope on table. Suddenly he jerks up one end of rope and a number of single knots have been formed in rope. He places rope on table again. In a moment Magician again jerks up one end of rope, and the knots have disappeared.

PARAPHERNALIA:

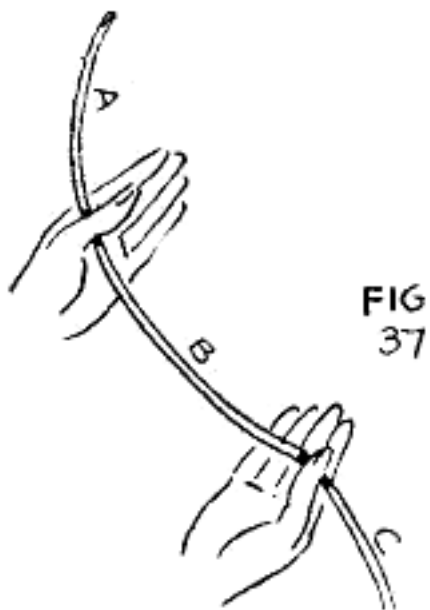
- 1--A piece of very soft clothesline, six to eight feet long.
- A piece of soft, twisted cord, such as is used to hold curtains or on bathrobes, is ideal for this experiment.

The rope used must be soft so that it will knot and unknit easily. Cut tassels from bathrobe cords and you will find these cords most satisfactory for use here.

SECRET:

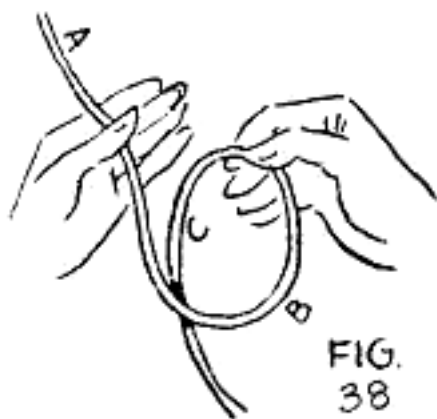
To Perform:

Hold rope near one end as shown in Figure 37. Rope lies over palms of both hands and is held in place by thumbs.



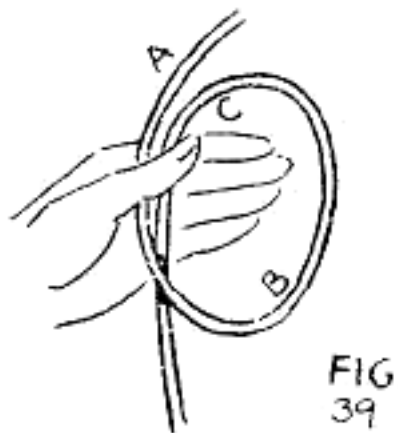
Bring right hand up, turning back of it to audience and tips of fingers toward left hand. Bring C part of rope up near left hand and let end of rope fall back of end in left hand.

Figure 38.

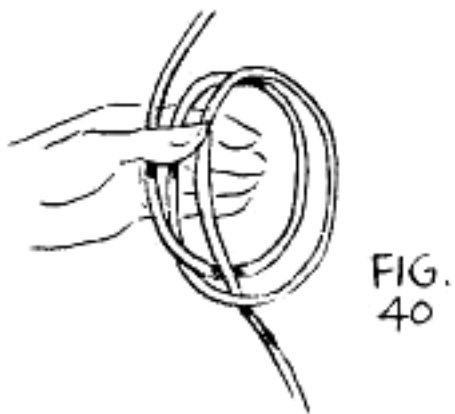


Grasp C in left hand, making a loop of rope. Size of this loop should be about six inches in diameter. You will have to experiment with size of loop to get the proper size for the particular rope you use. Size must be right to make forming of the knots easy.

Figure 39.



Take rope again in right hand in position shown in Figure 37. Make another loop in the rope, bringing end of rope back of loop again. Study Figure 40 carefully to get proper looping of rope.



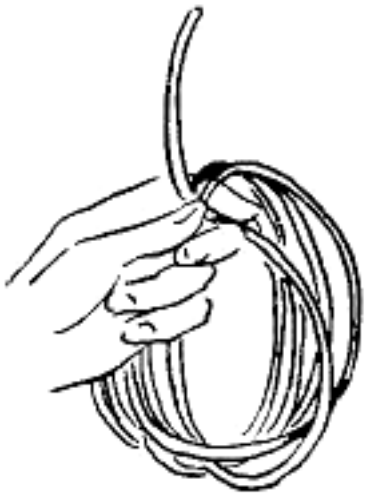


FIG.
41

Continue making loops until most of the rope has been used. When you reach the right-hand end, grasp it between thumb and first finger of left hand and release right hand.

Figure 41.

Place rope on table, and as you do so, pull right-hand end through the loops. Audience is not aware that you do this. To them it appears that you merely looped the rope and placed it on the table.



FIG
42

Now pick up right-hand end of rope and give whole rope a quick jerk.

Figure 42.

(37-12)



FIG
43

The rope will stretch out with a series of knots in it, about an equal distance apart. There will be a knot formed for every loop you made in the rope. Suspend rope from right hand and show.

Figure 43.

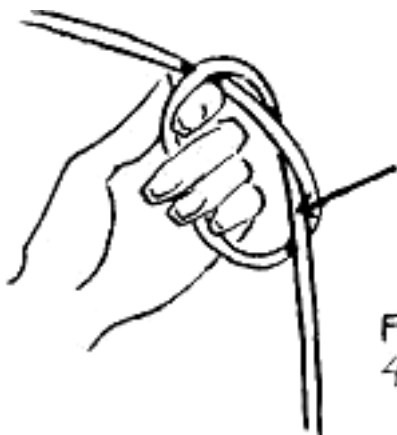


FIG
44

To Untie the Knots Magically:

Call attention to the fact that the knots are genuine by starting the first one and pulling it out big enough to insert the fingers of your left hand.

Study Figure 44 carefully. The exact position of knot and the point at which rope leaves knot are important things.

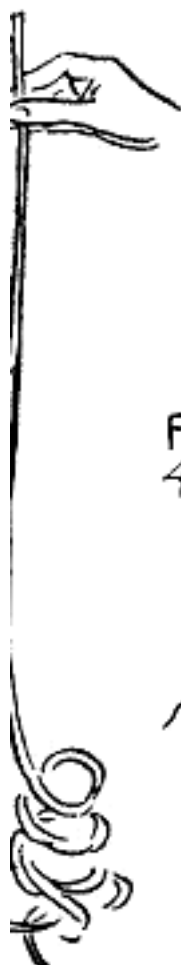


FIG
46

Take up the next knot, open it and hold in same manner as first one in left hand. Continue to do this until you have all the knots gathered up in left hand. Then grasp right-hand end of rope between thumb and first finger of left hand also.

Figure 45.

Pull right-hand end through loops and allow rest of rope to hang suspended from left hand. The knots automatically untie themselves and the rope hangs straight down.

Figure 46.

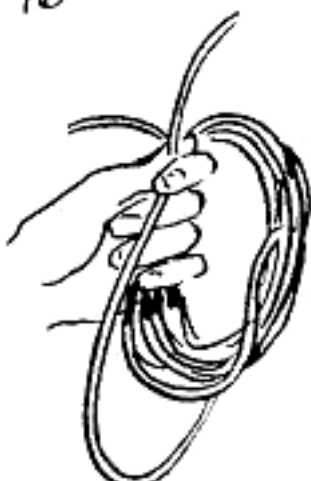


FIG
45

The tying and untying knots may be greatly elaborated on for stage production. Have two brass bowls or jars a few feet apart. Show each empty. Coil the rope and place it in one bowl. Do not pull end through loops until rope is concealed in bowl. Take another rope and tie the series of knots in it as taught to you above. Gather up the knots—see Figures 44, 45. Place rope in second bowl. When it is concealed, pull right-hand end of rope through the loops.



FIG.
47

Now you proceed to show the sympathetic nature between the ropes. Pull out the first rope and show that knots have appeared in it. Take out the second rope, which was knotted, and show that the knots have disappeared.

Figure 47.

(37-13)

CHEFALO'S KNOT

I believe this knot was brought out by Chefalo, the famous Italian Magician. It works very nicely in an Oriental program.

EFFECT:

Performer ties a double knot. Then to make knot even more secure, he loops an end of the rope through the knot several times. In spite of this, the knot disappears on command.

PARAPHERNALIA:

1--A piece of rope or cord.

SECRET:

To Perform:

Tie a single knot in center of rope. Note just how knot is made with part 1 of the rope coming up behind part 2.

Figure 48.

Tie another single knot. This time part 1 comes in front of part 2.

Figure 49.

Bring right end of rope down through loop A.

Figure 50.

Now bring same end of rope up through loop B.

Figure 51.

Pull on both ends of rope and knots disappear.

To give this experiment a Japanese or Chinese atmosphere, perform it this way: After knot is tied, give one end to one assistant and the other to a second assistant. Stand behind knot and fan it. As you fan, assistants pull rope and knot disappears.



FIG. 48

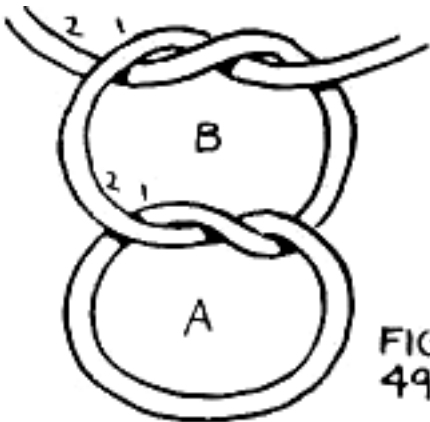


FIG. 49

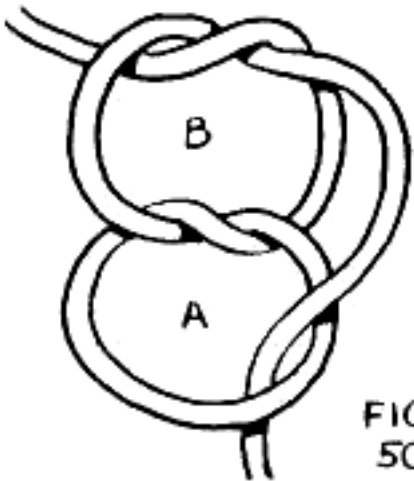


FIG. 50

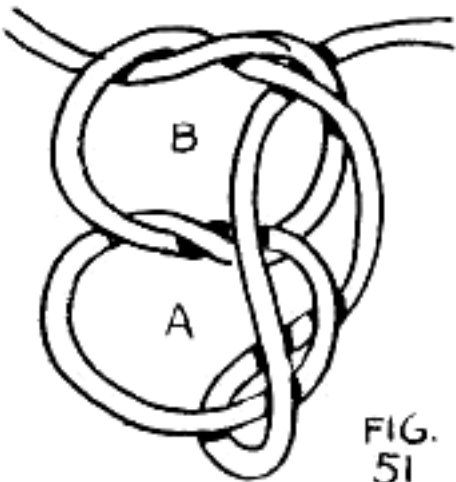


FIG. 51

If performing Chefalo's Knot at a club or dinner engagement and using patter, explain that this knot is one of the strongest knots used by sailors. Not only is it a double knot, but it is made even more secure by putting end of rope through the loops.

* * * * *

MYSTERIOUS JAPANESE TIE

EFFECT:

Performer ties two tapes around a girl assistant's waist. Another girl stands in front of the first and is also bound with the tapes. Two ends of the tapes are given to an assistant and performer, himself, holds the other two ends. At command, the tapes are freed from the girls and are shown stretched out between the performer and his assistant.

PARAPHERNALIA:

1--Two tapes, each about 16 feet long. The tape should be about 1 inch wide, and the length should fit in with the requirements of the performer.

2--A needle threaded with color to match tapes.

SECRET:

To Prepare:

Stretch out tapes on top of each other. Take the thread and needle and sew the two tapes together loosely across the middle. Just a loop of double thread through tapes with ends of thread tied together is sufficient.

Figure 52.

Fold up tapes carefully and place aside for use.

To Perform:

Stretch tapes out between two assistants and stand behind tapes.

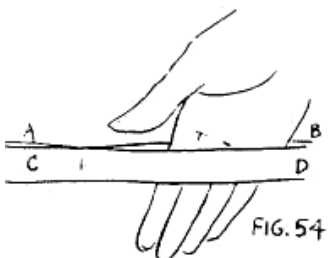
Figure 53.



Place right hand between tapes one to two feet to the right of thread joining tapes. Run hand up against joining.

Figure 54.

(37-15)



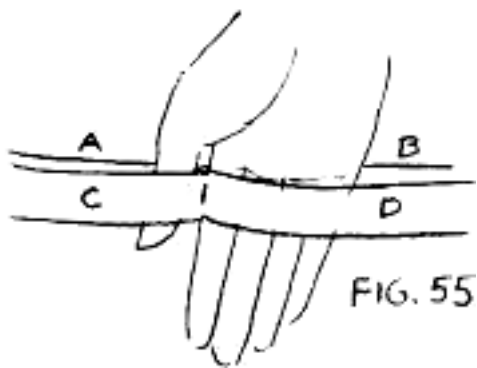


FIG. 55



FIG. 56

Place right thumb on left side of joining between the two tapes.

Figure 55.

Have girls drop the tapes and move to center of stage back of performer. When ends of tapes hang down from right hand, it is easy to place A against B and C against D to fold each tape back on itself. You were taught this same principle in an earlier lesson.

Figure 56.

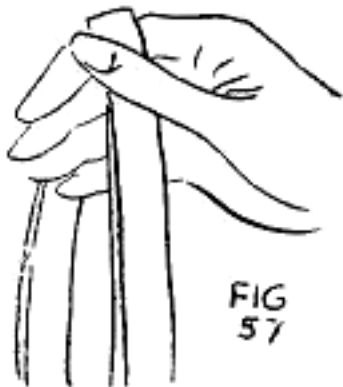


FIG 57

Grasp tapes over right hand with thumb concealing joining. Audience is not aware of your shifting of the tapes but believe you merely took tapes in your hand in their original position.

Figure 57.



FIG. 58

Place tapes around one of the girls with the joining at the back and the ends out toward the front.

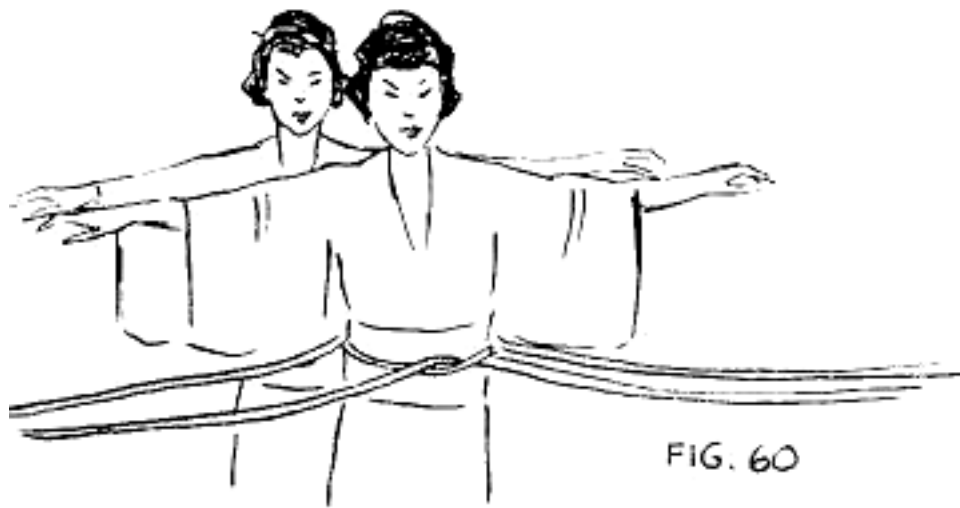
Figure 58 shows view away from audience.



FIG. 59

Tie a single knot in front with the tapes.

Figure 59.



Have second girl stand in front of first. Tie another single knot in front of her with ONLY ONE of the tapes. Have girls turn slowly around together to show that they are securely bound, then face front again.

Figure 60.

Have assistant hold ends of tapes at the left and you hold ends at the right, or vice versa.

(37-16)

Suddenly say, "Allay!" or make some other command. The rear girl pushes backward to break thread joining tapes and you and assistant pull on tapes. Tapes are released from girls and are stretched straight out in front of them. Separate tapes, holding one above the other to show them.

Figure 61.

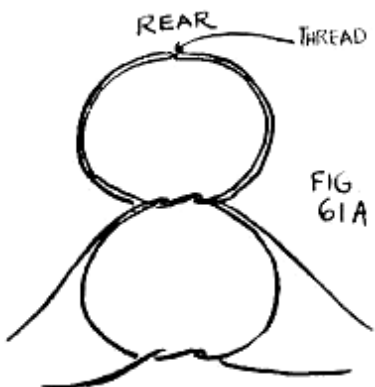
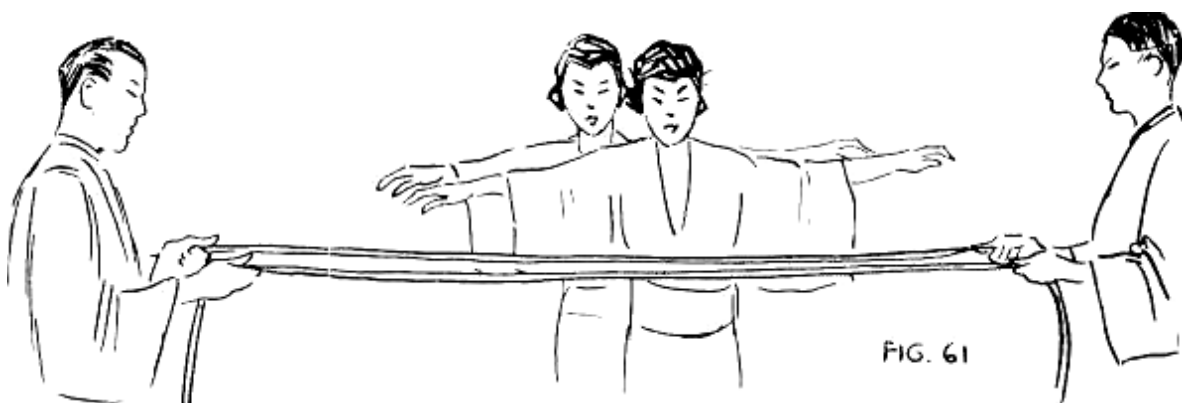


Figure 61A shows a diagram of the arrangement of the tapes around the girls.

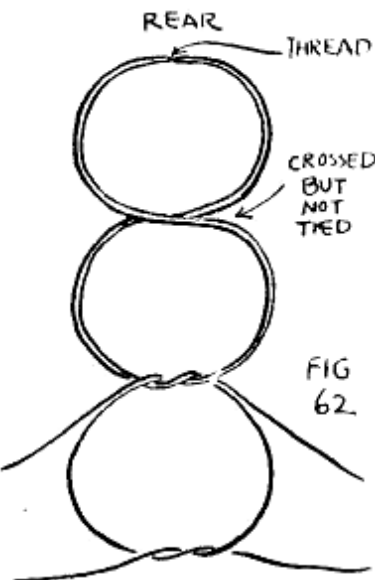


Figure 62 shows a diagram of tapes around three girls. Tapes are not tied, but merely crossed, in front of first girl. They are both tied in front of second girl, and then just one is tied in front of third girl. You may tie even more girls together. Just remember that tapes are only **CROSSED** in front of all girls except the front two.

Rear girl must always step backward to break thread joining tapes and facilitate freeing of the tapes.

This effect requires little equipment, yet it is flashy and can be made most effective. If desired, men assistants may be used instead of girls. Or it may be performed with spectators. If binding a man, tuck a bit of his coat over joining of tapes in back, so fake joint will not be seen when he turns around.

THE CHINESE BURNING TAPES

This effect has been very popular in Magic. It adapts itself to Oriental acts and to Occidental as well.

EFFECT:

Performer holds two tapes about ten feet long. Assistant lights a match and sets the tapes on fire in the middle. The tapes are burned in two and the two ends are held apart to show them separated. Burned ends are then brought together and opposite ends are held by assistants. Performer fans burning tapes and suddenly they are restored completely.

PARAPHERNALIA:

1--A roll of white tape, one inch wide.

2--Small box of matches.

3--A small Chinese or Japanese fan.

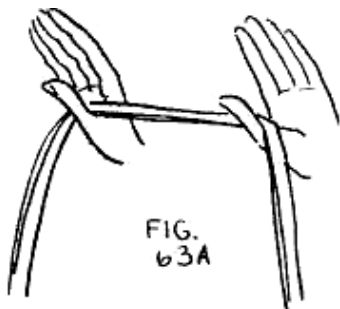
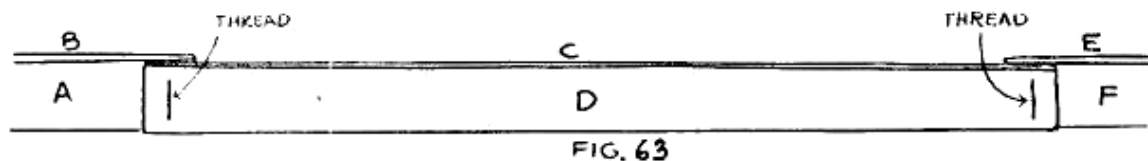
SECRET:

To Prepare:

Cut off two lengths of tape, each about 9 feet. Cut another piece about 27 inches long.

Fold over each piece of tape and crease slightly in the middle. Sew the doubled short piece of tape at each end to the folded end of each of the long tapes. Use just a loop of white thread to fasten the tapes so that it can be broken easily.

Figure 63.



Hold tapes at the two joinings in crotches of both thumbs and stretched across from hand to hand. When held this way, they look like ordinary unprepared tapes.

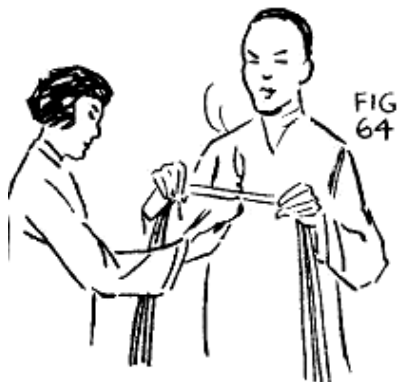
Figure 63A.

Roll or fold tapes and place them aside in readiness for experiment.

Some performers like to fireproof folded ends of long tapes where joinings are made. This is done by dipping ends in a solution of alum or of chloride of zinc. This allows the middle tape to be burned up entirely and eliminates the necessity of palming the remains of the short tape.

To Perform:

Bring forth the tapes. Unroll and hold in hands as in Figure 63A. Thumbs cover the joinings. Throw out the tapes so that audience can see the whole length of them. If you keep them in motion, joinings will not show. Then hold them up in crotches of thumbs again.



Now bring fingers down and hold tapes as in Figure 64. Have assistant light match and set fire to middle piece.



When tapes are burned apart, hold the burning ends away from each other to show audience that tapes are actually separated.

Figure 65.



FIG. 66

Bring burning ends together again and let them burn down for a while.

Figure 66.

Have two assistants pick up free ends of tapes. One must take ends B and E and the other, ends A and F. See Figure 63. You can aid assistants in getting right ends. You may put special marks on tapes to help assistants distinguish ends which they are to hold. The important thing is to get one of the right-hand ends over to the left and one of the left-hand ends over to the right.

When assistants have tapes, bring out fan with right hand. Strike burning ends with side of closed fan to extinguish the fire. As you do so, steal the remains of the short piece of tape with right hand. Pinch these pieces between thumb and base of forefinger, break thread and pull off the pieces, palming them in right hand. (If you have fireproofed large tapes, and allow short tape to burn away completely, this part is not necessary.)

Figure 67.



FIG 67

Open fan with right hand while you close left hand over supposedly burned portion of large tapes. Assistants pull tapes tight. Fan left hand, being careful not to expose palmed pieces in right hand. Slowly open left hand and show it empty with fingers wide apart. Assistants hold tapes far apart to show them completely restored.

Figure 68.

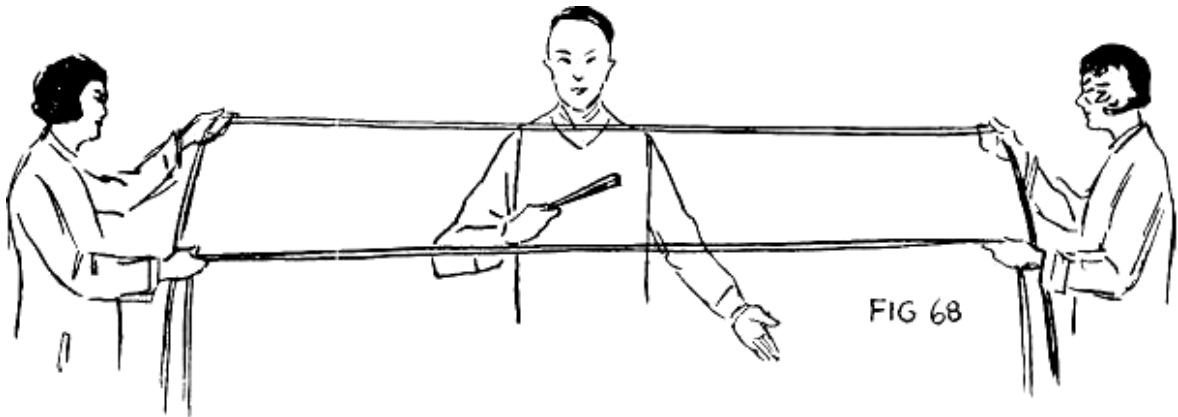


FIG 68

HINDU CUT AND RESTORED TURBAN

There is a difference of opinion as to the origin of this trick. Some say it came from India, while others contend that it came from Egypt originally. However, where it started makes no difference. It is a good effect and can be presented as either a Hindu or an Egyptian effect. It may be adapted to Chinese or Japanese Magic by presenting it with just a piece of cloth and not emphasizing the fact that it is a turban cloth.

EFFECT:

Performer removes a turban from one of his assistants, unrolls it, and has two assistants hold it by the ends. Magician then take turban and has assistant cut it in two in the middle. The two cut ends are then burned for a while. The fire is extinguished and the burned ends are evened up with a pair of scissors. An instant later the turban cloth is made whole again and is spread out between the assistants.

PARAPHERNALIA:

1--A piece of cheese cloth, about ten or twelve feet long. It may be used full width, but half width is usually better and easier to handle. 2--A pair of sharp scissors.

3--A box of matches.

SECRET AND PATTERN:

To Perform:

Come forward with turban cloth and scissors. Have three spectators come up to assist you. Have one stand at your left and the other two at your right.

"This is a Hindu mystery which I am about to perform in exactly the same manner as the Hindu does in India. He takes his turban, unrolls it, and spreads it out before him."

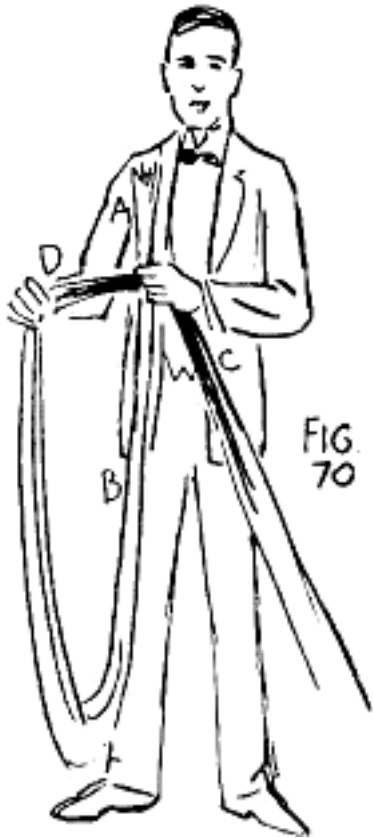
Give one end of cloth to assistant at your left and other end to one of assistants at right. Have them stand far enough apart to stretch cloth out full length between them. Have third assistant come up to middle of cloth and give him the pair of scissors.

Figure 69.



Look from gentleman at your left to gentleman at your right and then back again and say:

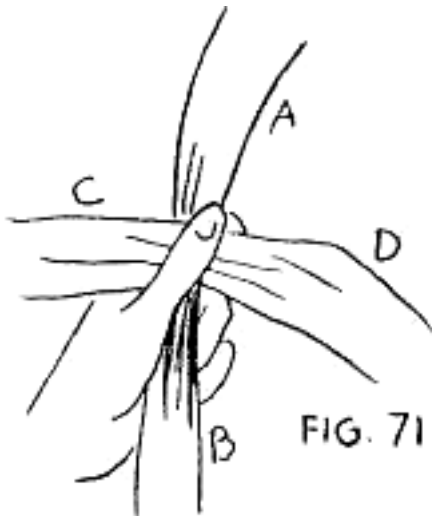
"The distance from the gentleman here to the gentleman there is the same as the distance from the gentleman there to the gentleman here."



Now gather up the cloth across the width and have assistants drop ends. Grasp right end of cloth and bring it up in front of middle of cloth. Hold in left hand.

Figure 70 shows view as seen from audience.

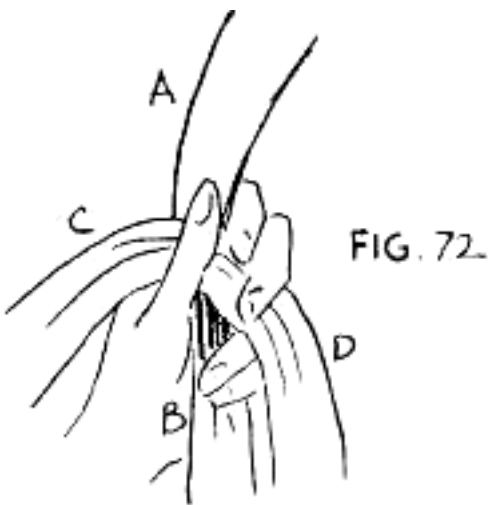
Figure 71 shows diagram of cloth as held in left hand. This view is as you see it, away from audience. Right end A is brought up in front of middle of cloth C. B is the looped part and D is the end going out to right hand.



Pull middle part of cloth out with right hand toward the right.

"This, I believe, is the center of the cloth. The center is usually in the middle."

Drop end of cloth from left hand so that audience can see plainly that you hold middle of cloth between your hands. Pick up right end of cloth again and hold as in Figure 71.



Let D drop from right hand. Place two upper fingers of left hand on D and two lower fingers on B to separate the two parts.

Figure 72.

Say to gentleman with scissors:

"I suppose you do not mind going through a psychological test before we begin operating. Did you ever hear of the famous Dr. Roosen-woofle of Europe who made mental tests? Perhaps not. When I count three, tell me quickly what you have in your hands. One - two - three!"

As you begin to count, place right hand on B and bring it back toward yourself and up around D.

This move links end A and B through C and D parts of cloth.

Figure 73 and 74.



FIG. 73

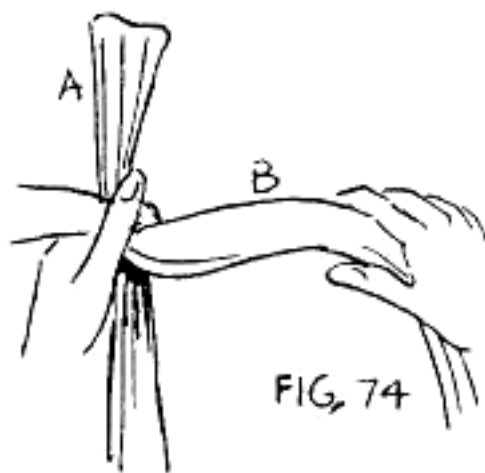


FIG. 74

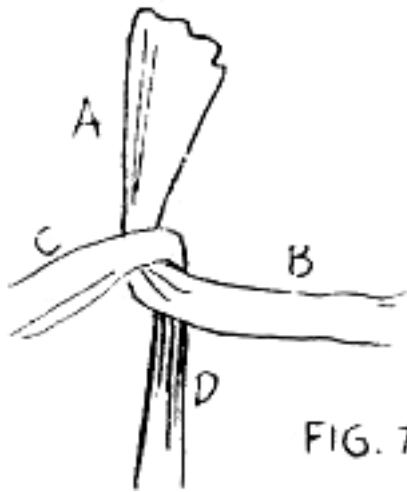


FIG. 75

Figure 75 is a diagram, showing the linking of A and B through C and D. The left fingers cover this linking. To the audience it appears that you hold the turban cloth as you did at first—see Figures 70 and 71. They are not aware of your substitution of B for D.

Upon this move, the whole trick depends. Spectators are led to believe that you hold middle of cloth in your hands, but in reality you hold only a piece near the end.

When you have counted three, assistant says, "Scissors." You repeat it after him.

"Scissors. Ah, sir, you are mentally qualified. I shall have you cut this turban cloth right through the center."

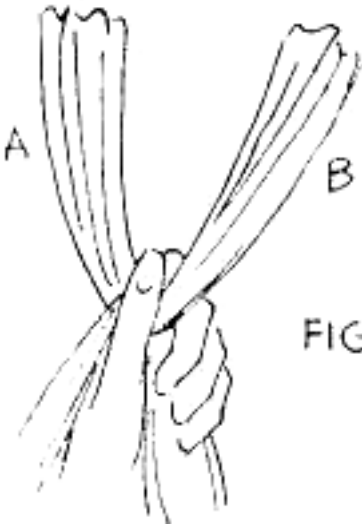


FIG. 76

Assistant cuts the cloth through B. The short end A and B extends upward and the rest of B falls to the floor. To the audience it appears that the turban has been cut in half and that the two ends are the ends of each half.

Figure 76.

"In the words of the poet--' It was the unkindest cut of all.' "

Give left end on floor to assistant at left and right end to assistant at right.



FIG. 77

Strike a match and light the ends of the short piece A and B. The flames have a pretty effect for stage work, so let the ends burn off a little.

Figure 77.

(If performing in a home or any place where fire is not practical, omit this part of experiment.)

Cut off burning ends of cloth with scissors—or if you prefer, extinguish the flames with the scissors before cutting ends.

"When the old Hindu Magician taught me this experiment he emphasized particularly the point that I must have the two ends even."

Cut one end off shorter than the other.

"Just look at that! The other is longer now."

Cut off short pieces from each end, and as you do so, say to the gentleman at the right:

"She loves me—she loves me not—she loves me."

Finally cut A and B away entirely. This leaves the whole piece of cloth C and D in your hand. Wrap turban around your hand several times.

"As I explained in the beginning, the distance from the gentleman here (point to man at left) to the gentleman here (point to man at right) is the same distance as from the gentleman here (point to man at right) to the gentleman here (point to man at left). All of which may account for the fact ..."

Unroll turban from hand and allow it to fall stretched out between the two gentlemen.

"That the turban is whole again and in one piece."

Have two assistants stretch turban out again full width as in Figure 69.

"You know it isn't so— even if it is!"

NOTE: The turban effect works nicely in pantomimic style in a Hindu or Chinese Act, but for ordinary performance, it works better with patter.

* * * * *

REVIEW

Lessons 25 to 37

Before you go any further with your Magic studies, I want you to stop again for review. Go back to Lesson 13—read the introduction and review the outline there very carefully. Then turn to Lesson 25 and study the second outline thoroughly.

You will find it fascinating and inspiring to go back this way and check up on yourself. You will be amazed at the vast amount of Magic you have learned and at the remarkable progress you have made.

Now I want to give you your third review outline, which will cover Lessons 25 to 37.

Lesson 25 -- Effects with rabbits or other small animals. In this lesson you learn effects which enable you to give excellent children's programs.

Construction of production vanishes. This part of the course is invaluable to you for it saves you considerable money and teaches you how to create in Magic.

Lesson 26 -- Introduction on Simplicity as Keynote in this Course.

Colorful Ribbon effects.

Good Mathematical mysteries.

Lesson 27 -- Famous Needle Trick.

Valuable work on Thimble Manipulation, and complete Thimble Act with vanishes, productions, and effects.

Lesson 28 -- Magic with Silks—principles and effects.

Lesson 29 -- Mind Reading--Super-Mental work with a real punch. Complete Mind Reading Act.

Review the introduction on Opportunities in Magic, Specialization, Presentation, Creating of Effects.

Lesson 30 -- Business side of Magic--a lesson which will help to "make" you. How to make money--how to sell yourself--how to get bookings--advertising and publicity.

You learn how to put on a whole evening's show. Complete programs--how to stage and present them.

Besides, several interesting productions with construction of rabbit boxes and bags.

Lesson 31 -- More Super-Mentalism and Mind Reading to make a real reputation for you.

Principles and routines on mental work which you should master thoroughly.

Lesson 32 -- Your relation to other Magicians and Ethics at a Magic performance--read this many times.

Silk Handkerchief Magic --

Principles of tying and untying magical knots.

Principles of vanishing and producing handkerchiefs. Good effects with handkerchiefs.

Lesson 33 -- Cigarette Magic.

Principles of Sleight of Hand with cigarettes and Effects involving these manipulations.

Lesson 34 -- 12 Impromptu Card Effects.

These should be mastered so completely that they become a part of you.

Lesson 35 -- Sleight of Hand with Cards.

Principles used by the world's greatest Magicians and new angles to make your work "different."

Lesson 36 -- More Card Magic --

Flourishes - Forces - False Counting - Four Ace Work - Rising Cards - Card Fountains.

Today's lesson is one of the lessons on Oriental Magic included in your Course.

* * * * *

LESSON 38

More Oriental Magic with effects from far distant lands which are fascinating to learn. You will find that these interesting effects go over big with an audience.

ORIENTAL MAGIC

In this lesson we continue our study of Oriental Magic. I teach you effects which will make a fine addition to your repertoire.

JAP-O-TIE

Tarbell Version of Japanese Thumb Tie

In Lesson 11, I taught you a thumb tie with pipe cleaners and one with rubber bands. I promised you at that time to teach you another method of performing the thumb tie which does not necessitate pulling the thumb in and out of the tie.

As far as I know, Jap-O-Tie is original with me—although it may have been performed by Japanese Magicians hundreds of years ago. I have used Jap-O-Tie with good success. It is very simple, and yet most elusive. It is so bold in nature that its very boldness adds mystification to it.

EFFECT:

Performer's left thumb is securely bound and tied with tape. The same is done with the right thumb. The two thumbs are then placed together and bound tightly. In spite of the tying of his thumbs individually and together, the performer now passes rings and poles between his hands to the complete mystification of all spectators.

PARAPHERNALIA:

- 1 -- Two pieces of white tape, about $\frac{1}{2}$ of an inch wide and 12 inches long.
- 2 -- Pair of scissors.
- 3 -- A pole.
- 4 -- Two wooden or steel rings about 8 inches in diameter.

SECRET AND PATTERN:

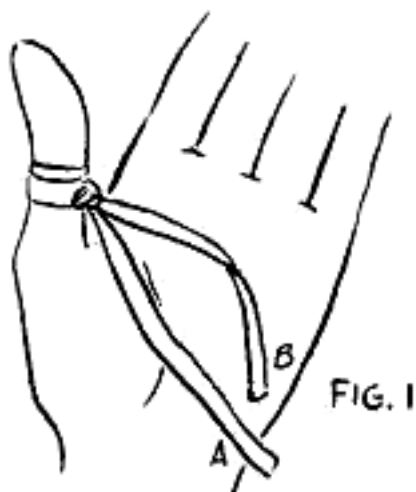
To Perform:

Have a spectator wrap one piece of tape twice around your left thumb and tie it securely on under side of thumb. Allow him to make two or three knots.

Figure 1.

"Tie the tape good and tight."

Have the spectator wrap the other piece of tape twice around your right thumb, tying it well on upper side of thumb.



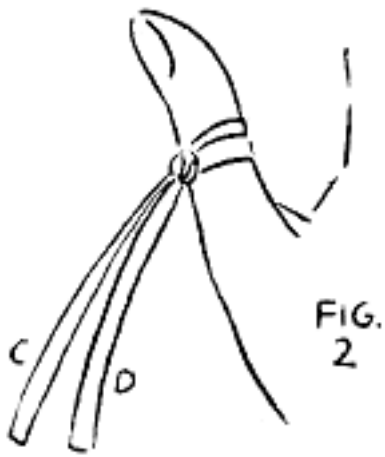
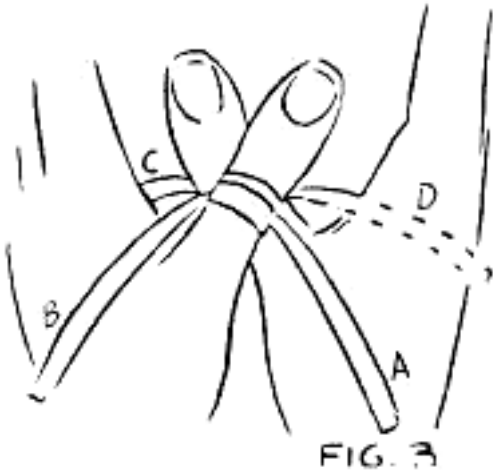
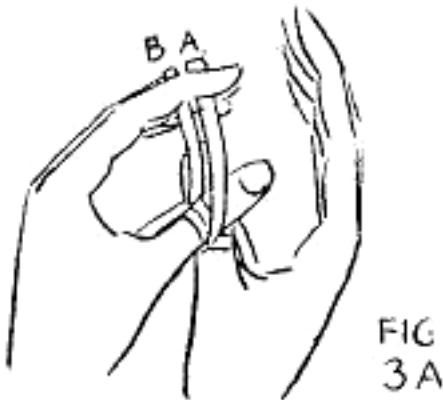


Figure 2.



Place left thumb on right thumb. Wave your hands back and forth a moment to throw ends A and B on upper sides of hands and ends C and D on under sides of hands. Waving of the hands confuses the spectators and leads them to believe that each pair of ends is now around opposite thumb. In reality each pair of ends is around its own thumb.

Figure 3.

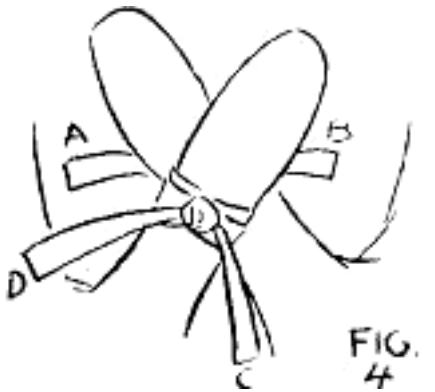


With a slight wave of hands, get ends A and B between left fingers to lift them up out of the way.

Figure 3A.

Then say to spectator:

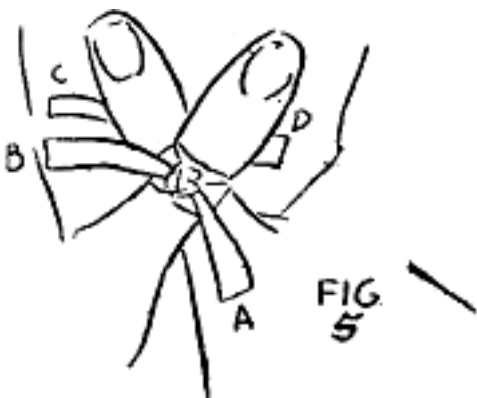
"I shall ask you now to tie the upper thumb to the lower one. Pull tight and tie a good knot."



Hold thumbs up so that spectator can tie ends C and D around lower thumb.

Figure 4.

"Now, secure the lower thumb to the upper doubly well by tying these other two ends together."



Turn backs of hands up and have spectator tie ends A and B on top of upper thumb.

Figure 5.

To audience:

"Note carefully how my thumbs have been securely tied. Each thumb has been wrapped with tape and tied and then both thumbs have twice been securely tied together. As you can readily see, such a tie would bind me securely, and my only hope of release would be to have someone cut the tapes off with a knife or pair of scissors."

Show thumbs to audience. They appear to be tied securely together, yet each thumb is entirely separate from the other.

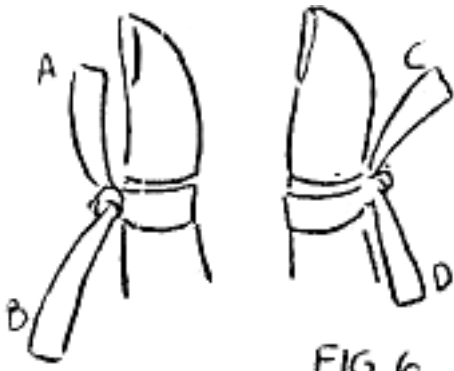


FIG. 6

Figure 6 shows a side view of manner in which thumbs are tied. Thumbs are pulled apart to show this clearly. Of course, you do not permit the audience to see such a view as is shown in Figure 6.

It is now an easy matter for you to pass objects between your hands. First, start with the pole. Place your hands in

(38-2)

front of the pole which is being held by spectator. Thrust hands toward pole.

Figure 7.



As hands reach pole, separate them enough to get pole between them and bring thumbs together again immediately on other side of pole. Show thumbs tied. This must be done in a flash so that spectator cannot see separating of the hands.

Figure 8.



Bring hands away from pole in same manner.

Next have spectator toss rings to you, one at a time. Catch them between hands and allow them to slip over right or left arm. Release rings from arm again in same manner.

Figure 9.

To finish have tapes cut from thumbs with a pair of scissors, preferably by your own assistant.

NOTE:

This tie can be worked at angles and under conditions impossible with the regular method. It may be performed down in the audience with people all around you. You may permit short examination of thumbs when they are together.

* * * * *

THE MYSTIC SMOKE

EFFECT:

Performer shows an empty pitcher. He places lid on it and covers it with a cloth. From a lighted cigarette, he blows three puffs of smoke at the covered pitcher. He then removes the cloth and lifts the lid from the pitcher. Clouds of smoke arise from it as if it had filled itself with the cigarette smoke which Magician blew toward it.

PARAPHERNALIA:

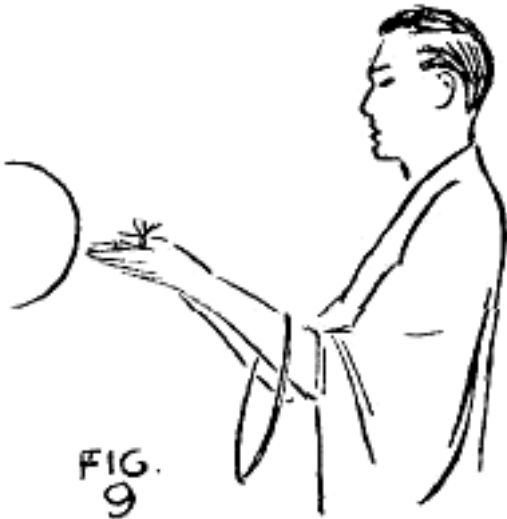




FIG.
10

1 -- A glass pitcher with glass top--or a tall glass vase with top.

Figure 10.

2 -- Bottle of ammonia.

(38-3)

3 -- Small bottle of muriatic acid. Be very careful in handling this acid as it is powerful and burns flesh and clothing.

4 -- A square of silk or cotton cloth--plain or with Oriental pattern.

5 -- A tray on which to place pitcher, lid, and cloth.

6 -- A cigarette.

SECRET:

This is a chemical trick.

To Prepare:

Place a half teaspoonful of ammonia in the bottom of the pitcher. Have lid on tray and place a few drops of the muriatic acid on bottom of lid. Keep the lid away from pitcher for when the fumes of ammonia and of muriatic acid come together, smoke is produced. Experiment to get the proper amount of ammonia and acid for the size of pitcher or vase you are using.

If you have an assistant, have him or her prepare pitcher and lid a few moments before you are ready for the experiment.

To Perform:



Assistant brings in prepared pitcher with lid and cloth on tray.

Figure 11.



Pick up pitcher and show it empty, then replace on tray. Pick up lid and cloth. Place cloth in front of pitcher as you cover it with top. Then continue to place cloth over entire pitcher. This is done to prevent spectators from seeing formation of smoke.

Figure 13.



Light a cigarette and puff three times at covered pitcher.

Figure 13.

Now lift cloth from pitcher and show smoke to spectators. Lift lid and allow smoke to rise out of the pitcher.

Figure 14.

* * * * *

THE CHINESE STICKS

An excellent Chinese "sucker" trick that permits of good comedy.

EFFECT:

Performer shows two sticks, each about a foot long. He holds them parallel and shows that a string runs through one stick and across and through the other one. He cuts the string between the two sticks and shows the sticks separated. Suddenly he brings the two sticks together again and shows the string has been restored. Once more he cuts the string and separates sticks. He pulls the short end of string, and as it becomes long, the other separated end becomes short and vice versa. If desired, one stick may be given to a boy to hold and above effect of shortening and lengthening string performed.

PARAPHERNALIA:

1 -- Two specially prepared Chinese sticks. We can supply you with two sticks at a nominal sum. These sticks are of the best grade as they are made specially for us and are patterned after the type of Chinese sticks which I use personally. They are built to eliminate noise in operation.

Figures 15-16-17 show construction of the sticks. Each is a foot long and about 3/8 of an inch thick. They are made of round black tubing, lined with celluloid, and decorated with Chinese red tassel. Chinese decorations can be put on with red or yellow lacquer if you prefer more colorful sticks. Inside a weight slides up and down. At the top of weight is an eyelet, through which a cord passes.

About 3/4 of an inch from top of stick, the cord passes through to the outside and is attached to a small brass ring. At the opposite side, cord passes through and is attached to a tassel. As weight slides to bottom of tube, tassel end of string shortens. As tassel is pulled down to lengthen string, weight goes up in tube.

When tube is held horizontally, weight does not move, but when tube is slanted with bottom downward, weight slides to bottom and shortens cord, pulling tassel up to tube.

(38-5)



FIG. 14

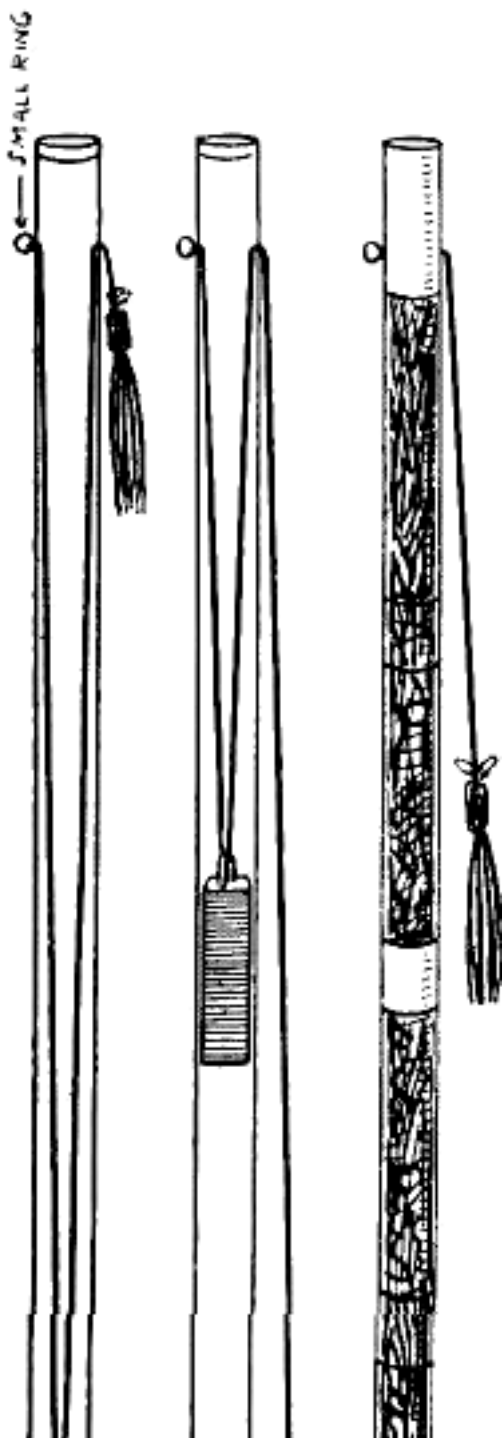




FIG
15



FIG
16



FIG
17

2 -- A pocket knife or pair of scissors.

SECRET AND PATTEN:

To Perform:

Arrange the L stick with string long and the R stick with string short. Hold the two sticks in horizontal position in left hand. Come forward with the two sticks, L and R. The flattened sides of sticks are together and the red lines running along each stick are placed together.

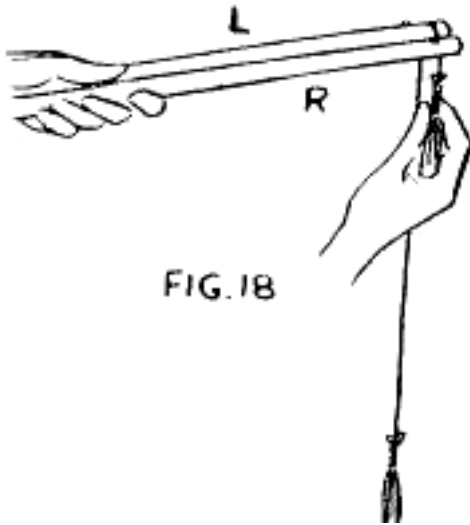
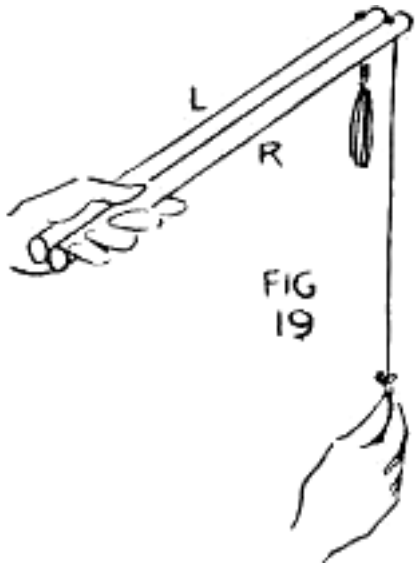


Figure 18.

You are now ready to start trick by showing that the cord runs through the ends of the sticks. To the audience it appears that the cord runs through from one stick to the other and has a tassel on each end.

Figure 18.

"Many years ago a celebrated Chinese Magician brought to this country a very peculiar problem with two sticks and a piece of string. The string, as you will notice, runs through the ends of the sticks."



Pull down on string R with right hand. As you do so, raise outer ends of sticks. This causes weight in L to slide down and thus shortens string L. The two strings must move in unison to give appearance of being connected.

Figure 19.

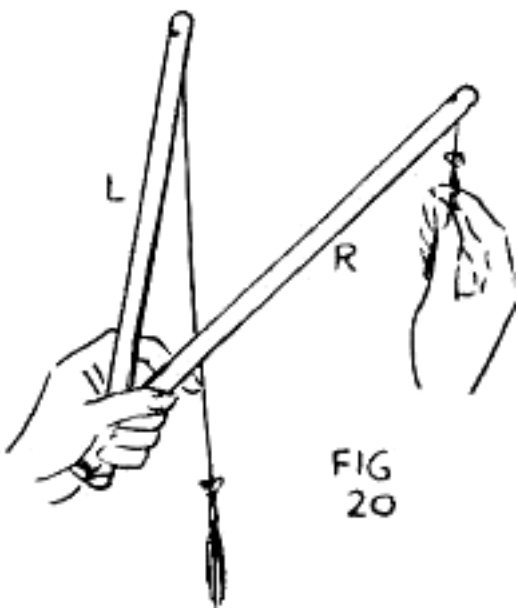
Bring sticks to horizontal position again. This time pull down on string L with right hand. Slant sticks upward so that string R becomes short.

Repeat this once or twice more to give audience definite impression that string is one piece.

Now take knife or pair of scissors from pocket.

"I shall now cut the cord between the two sticks."

Pretend to cut cord between sticks. Place knife or scissors aside.



Separate two upper ends of sticks, being careful to keep lower ends close together. Audience now sees cord between sticks separated and believe that you actually cut cord.

Figure 20.

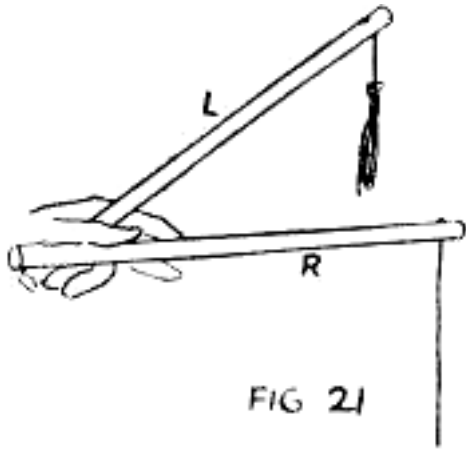
(38-6)

Close sticks together again as in Figure 18. Pull down on string R and slant sticks so that string L shortens.

"But, you see, a mere cutting of the string has no effect on it. It runs back and forth through the ends of the sticks as it did before."

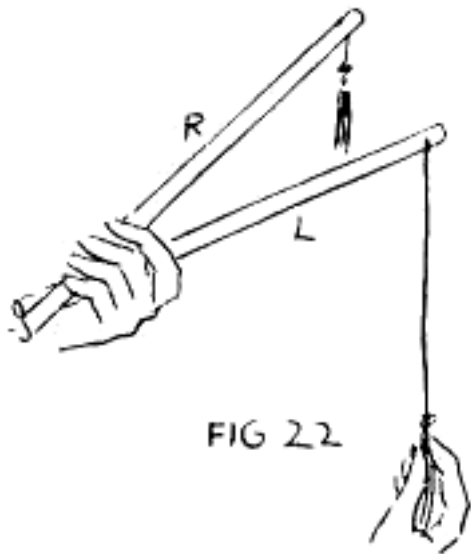
Pretend to pull string through ends of sticks, back and forth about three times. Finish with L string long.

Now pretend to cut string between sticks again with knife or scissors. Hold sticks horizontally and separate the outer ends again.



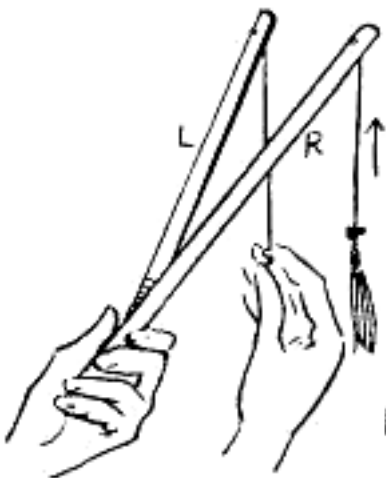
Pull on string R with right hand, and as you do so, turn left hand toward the right. This brings L stick up and R stick down. This movement causes string L to shorten and string R to lengthen.

Figure 21.



Grasp string I with right hand and pull it down. As you do so, turn left hand to the left so that stick R is raised, causing string R to shorten, and stick L comes to horizontal position.

Figure 22.



Repeat above moves of turning left hand and lengthening and shortening strings several times.

Figure 23.

"It seems to me that there is a wave of skepticism running through the audience about this invisible bond of sympathy between the sticks."

Pretend to overhear someone in audience.

"What's that? Move the other ends of the sticks apart?"

Look at ends of sticks which are held together.

"Oh, no, that isn't necessary."

Continue pulling together strings several times again.

"By keeping the ends of the sticks together, I can hold

them so much more easily."

By this time, audience believes that the string runs down the length of one stick, crosses over to the other at the point where you hold both ends together, and then runs up the other stick.

"Of course, you know that my holding the ends of the sticks together has nothing to do with the pulling of the cord."

Keep on pulling strings back and forth. Each time the audience is more convinced than ever that cord runs through the lower ends of the sticks.

Pretend to overhear a remark of a spectator.

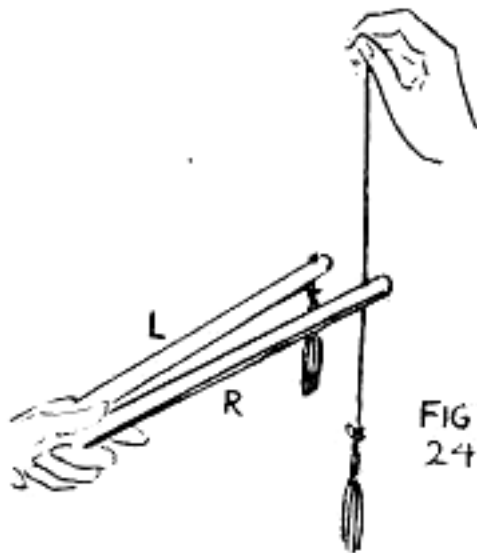
"Oh, I see. You think the string goes in this end of stick (point to end of stick where string R enters and follow movements with right hand as you describe them) and runs down to this end. then goes across to the other stick and runs up and out of the other end of this stick. No, no, I wouldn't think of doing a trick that way."

Pull string again to strengthen audience's theory. Then when string R is long and string L is short, separate the two sticks, holding one in each hand horizontally.

"No, there is no connection between the sticks."

Bring two lower ends of sticks together again in left hand. Pull down string L about an inch below stick.

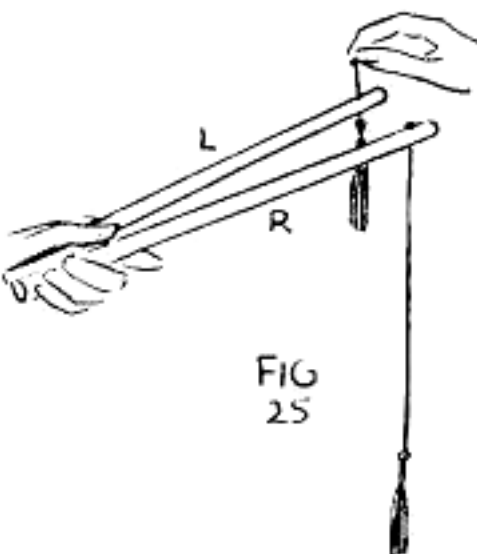
"I shall be glad to explain the real secret. You see, it is this way. When I cut the string in two, I naturally have two pieces. This long piece. . . ."



Pick up ring at top of stick R and pull string R up and down several times. Let ring drop back into place. This gives appearance of pulling the string to and fro directly

through the hole in stick.

Figure 24.

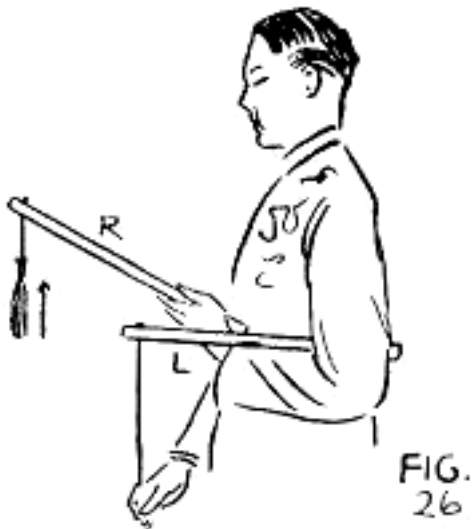


"And this little tiny piece."

Pull up on ring L just a little. Then pull down on tassel a little to give impression that this is just a short piece of string running through stick.

Figure 25.

"So I just pull on this tiny piece and it stretches out long while the long piece shrinks to a tiny little piece."

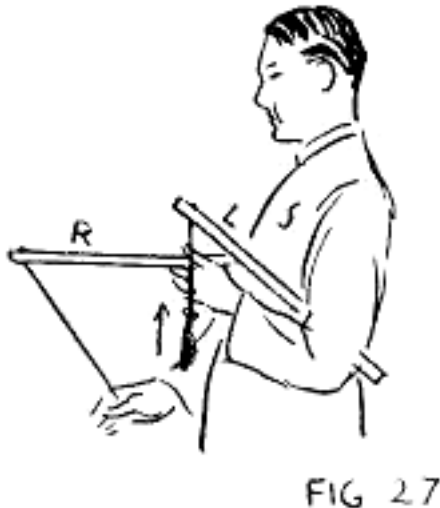


Place L over left forearm and hold it securely between body and upper arm and hold R in left hand. Pull down on string L with right hand, making it lengthen, and raise stick R to make string R shorten.

Figure 26.

Now pull strings up and down as above. See Figures 24 and 25.

"Or, if I pull on this other string, it grows long again while the other piece shrinks."



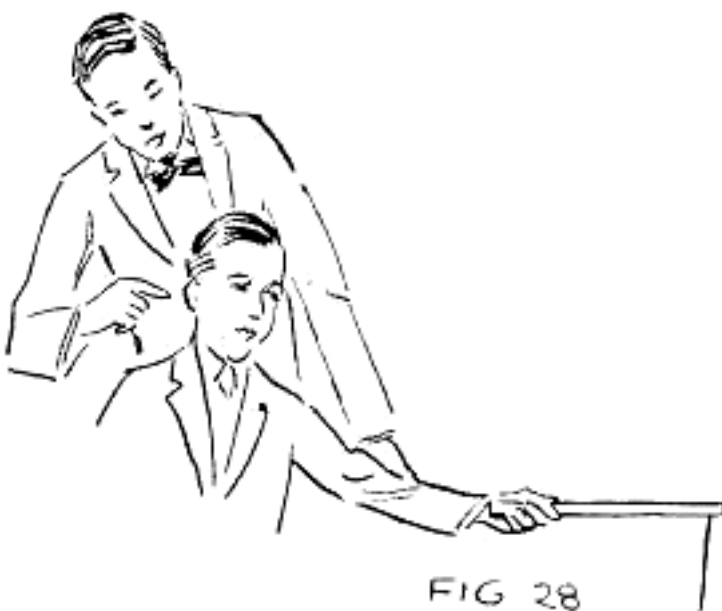
Pull string R down with right hand. Raise stick L with left forearm and cause string L to shorten.

Figure 27.

"It is just a stretching and shrinking process. As Confucius said to Shakespeare, 'If I be tall, then you be small-if I be small, then you be tall.' "

Illustrate this by shortening and lengthening the strings. NOTE:

This effect may be performed with a small boy and girl assisting. In this case, finish the experiment in this manner: Give stick with short string to the girl and stick with long string to the boy. Have boy hold stick with outer end lowered a little so that weight will not slide back and shorten string.



Place girl at left of stage and boy at right. You stand back of boy with your left hand on his left forearm to guide movement of stick.

Figure 28.

"This experiment is very simple if you pull your ear while doing it."

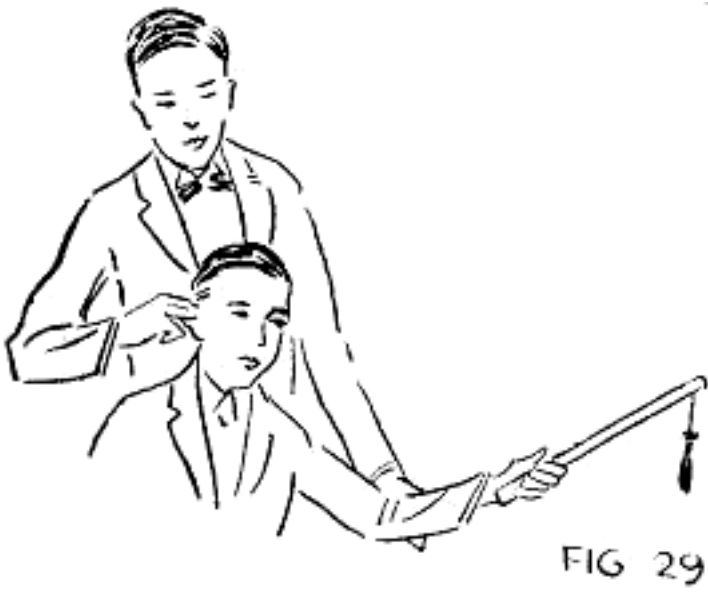
Place your right hand on boy's ear. Then say to girl:

"Hold your stick straight out at your side as if you were pointing to someone at the back of the room. When I give the signal, you pull on the tassel slowly and make the string grow long. At the same time, I will pull on John's ear and make his string grow short. Are you ready? All right -- pull on the string slowly now."

Pull slightly on John's ear, and as you do, raise his forearm enough to cause string to shorten.

Figure 29.

(38-9)



Suggestion:

It is well to coach girl secretly when you give her stick to hold, telling her to hold on to tassel and keep string long until you take stick from her. This will prevent her accidentally tipping stick and causing string to shorten.

Be on your guard, however. If you see girl slanting stick and shortening string, pull down on string of boy's stick.

Should her string shorten the same time as the boy's, take both sticks in your hands as in Figure 20.

"I almost forgot to tell you--when a girl touches one of the strings, the charm is broken and they both get short. But we can remedy the trouble by lengthening them both."

Pull down both strings, keeping sticks in horizontal position. Hold on to tassel R and say to girl:

"Now, you touch the stick at my left."

As she does so, raise stick so that string L shortens.

"See, it shortens at your touch."

Pull string L long and make string R to shorten. Then vice versa.

"See, they are all right again."

THE CLIMBING BALLS

This is a fascinating Hindu experiment. It is not difficult to perform but requires a little practice.

EFFECT:

Performer shows a pole about five or six feet long. Stretched from end to end are two strings supported by two wooden bridges. Three wooden balls are placed on the strings against the lower bridge. Magician holds the pole slanting upward and begins to turn in a circle. Slowly the first ball climbs to the top of the pole, then the second, and finally the third. He also makes the first ball climb to the top, the second one just to the middle, and the third one stays at the bottom. Various combinations may be secured, depending on the skill of the performer.

PARAPHERNALIA:

1 -- Special pole, which you may construct yourself. Secure a pole about five feet long--a bamboo fishing

pole or any round wooden stick about the size of a broomstick may be used. Get some heavy cord, such as fishing cord. Cut a groove around the pole near each end and tie two ends of string around one of these grooves.

Stretch the strings along the pole and tie at other end. Fashion two small bridges out of wood, each about 3 inches high. Cut out a semicircular piece from the bottom of each so that it will fit over the pole. Then about an inch down from the top of each cut a slit in each side for the cord to pass through. There must be enough of the bridges extending above the cord to keep balls from rolling off. Place the two bridges under the cord several inches from each end.

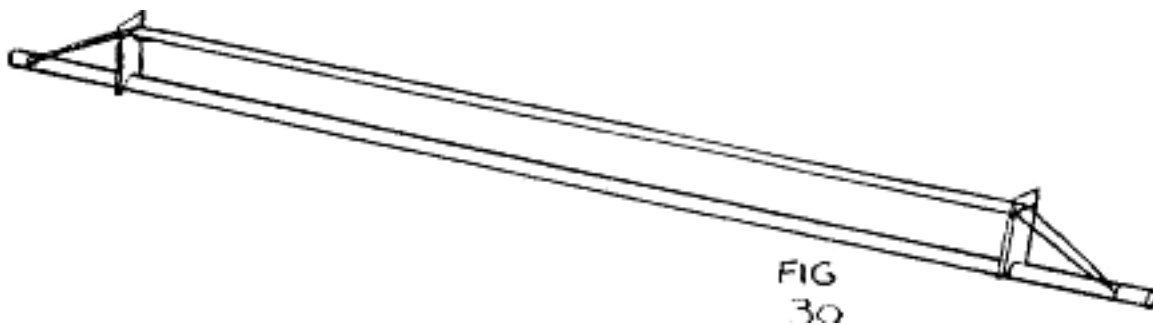


Figure 30.

2 -- Three balls.

The balls should be of wood, painted in bright colors, and two to three inches in diameter.

Composition balls are of ten used also.

The balls may be the same weight, but it is sometimes wise to have them vary in weight. Have B a little heavier than A, and C a little heavier than B. To accomplish this, plug the balls with lead.

Balls are placed on the two strings and are not attached in any way.

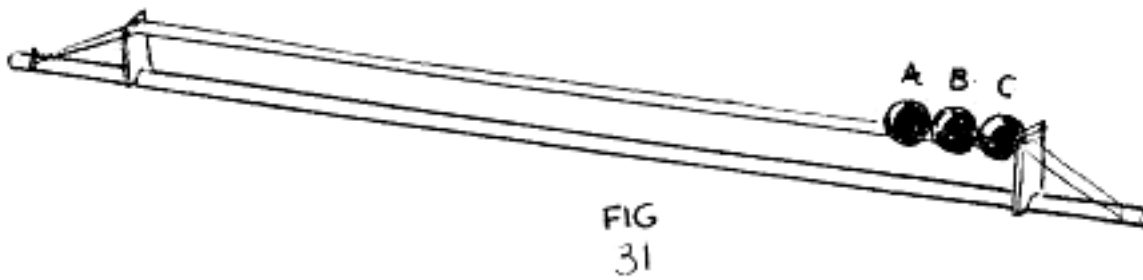


FIG 31

Figure 31.

SECRET:

To Perform:

This effect depends on a law of the Science of Physics—that of centrifugal force.

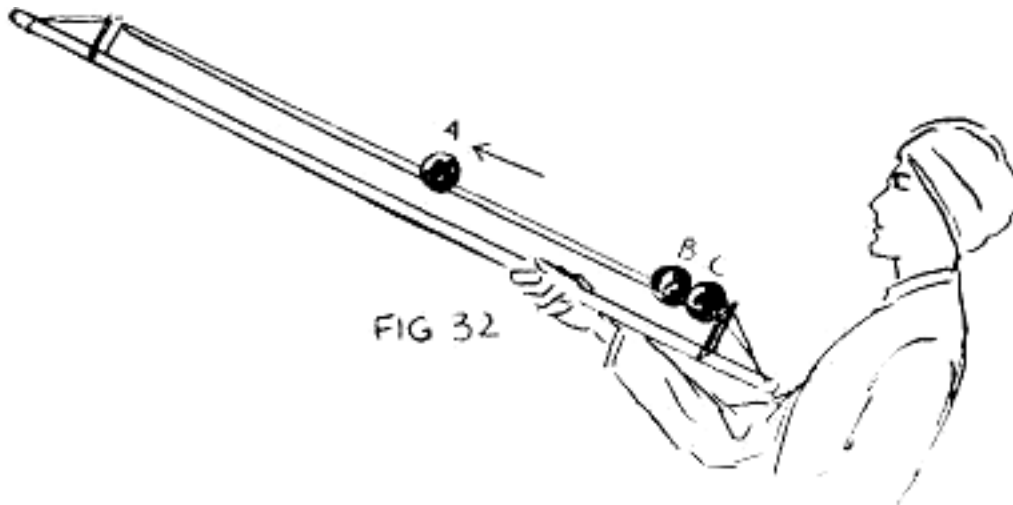


FIG 32

Hold pole in right hand with hand about 1/3 way from lower end and with lower end resting against right upper arm.

Figure 32.

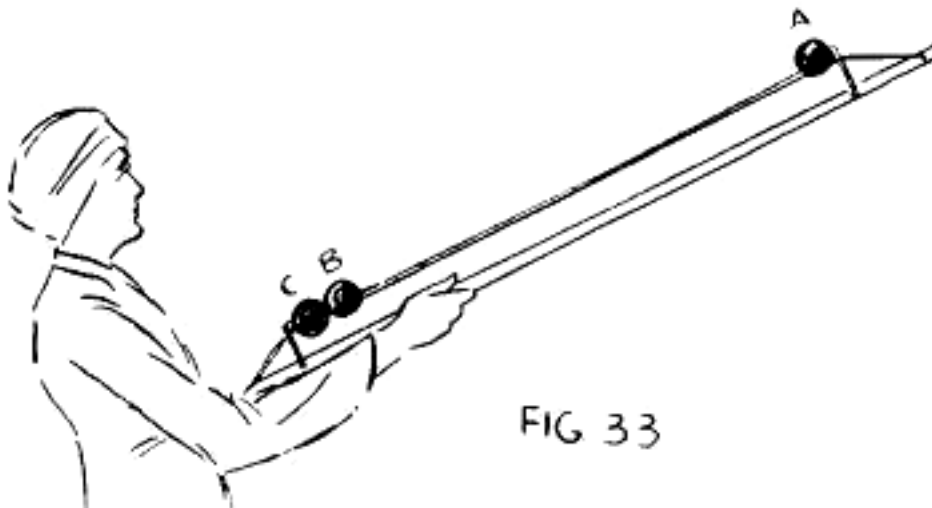


FIG 33

Begin to revolve to the left slowly, then gradually increase your speed until ball A starts up the incline slowly and finally reaches the top.

Figure 33.

Continue turning, regulating your speed until you succeed in getting ball

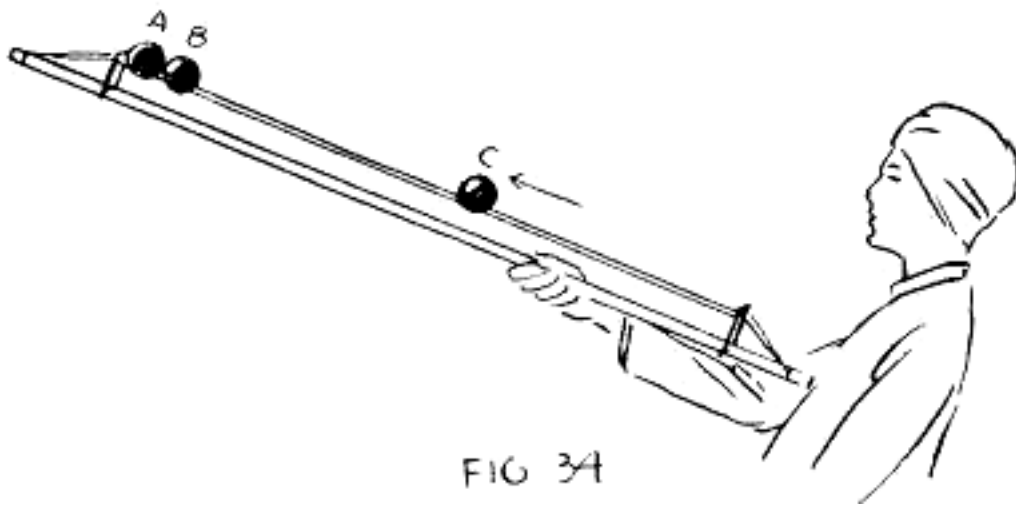


FIG 34

B to climb to the top of the pole, and finally ball C.

Figure 34.

Decrease your speed of revolving, and the balls will come down singly.

Some Hindus use only TWO balls and control them in a remarkable manner. They cause the first ball to ascend to the top and the second one only to the middle. Then they bring the second one to the bottom again and the first one down to the middle and then up again to the top.

You must have plenty of room to swing in. Be careful at first not to get dizzy. Practice will enable you to perform the experiment without difficulty.

The Hindu performs this effect out-of-doors, but the Occidental Magician usually performs inside and must arrange for sufficient swinging room.

You might try swinging the pole around your head instead of revolving your whole body.

* * * * *

THE DISAPPEARING GRAIN

EFFECT:

Performer fills a tin can with wheat or other grain and covers it with a cloth. He suddenly removes the cloth and finds that the grain has disappeared and the can is empty.

PARAPHERNALIA:

- 1 -- A box of grain. You may use any small grain or even bran. Use any kind of box for it that you wish.

Figure 35.

- 2 -- A tin can, especially prepared.

Get a can with the bottom sunk at least a quarter of an inch. A cardboard

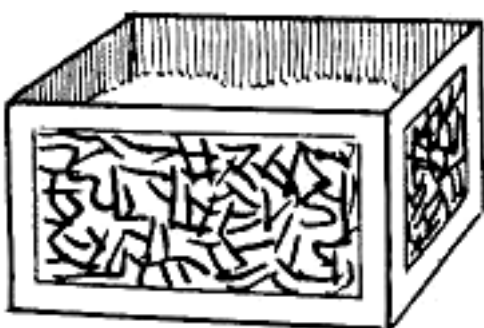
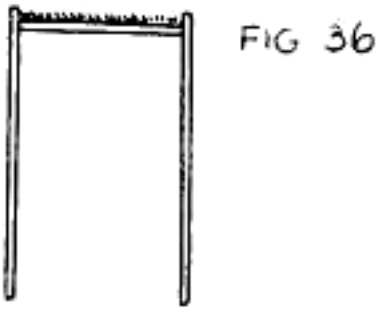


FIG 35

box or square wooden box with sunk bottom would also answer the purpose.

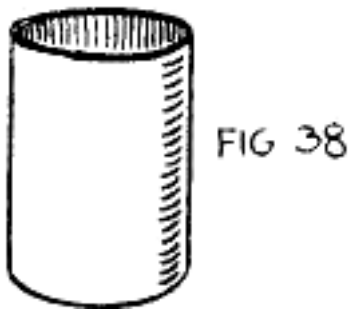


Prepare the can by covering sunken bottom with glue and then sprinkling grain on it. When can is shown upside down with top opening concealed, it looks like a can full of grain.

Figures 36 and 37.

When can is reversed with top up, it appears to be empty and unprepared. The secret of the effect is in

(38-12)



preparing can so that it can be shown apparently full of grain and then reversed and shown empty.

Figure 38.

3 -- A square of opaque cloth large enough to cover can completely. About an 18-inch square usually serves.

SECRET:

To Perform:

Show box of grain. Tip it and run hand through grain so that all can see it plainly. Show can empty, being careful to conceal bottom of it. Dip can into box of grain and fill, then pour grain back into box to convince audience that you actually fill can.



Place can in box of grain again, reverse it, and bring it up with grain piled on top of prepared bottom.

Figure 39.



With your hand, brush away the excess grain from the prepared bottom—that is, the grain which is loose. Cover can with cloth, and as you do so, reverse it to bring opening to top. Place covered can on table or hold in hand.

Figure 40.



Suddenly remove cloth and show both sides of it. Then lift up can. Hold bottom toward yourself and show it empty.

Figure 41.

THE HINDU JAR OF GRAIN

EFFECT:

Performer shows a jar filled with grain. He covers it with a cloth for a moment, and suddenly the grain disappears and the jar is empty.

PARAPHERNALIA:

1 -- A metal or earthenware jar, shaped like the one shown in Figure 42. It should be painted black inside. Cut out a piece of stiff black cloth to fit into the neck of the jar. Put glue over one side and cover with grain. When cloth is fitted into neck of jar, it appears that jar is full of grain.

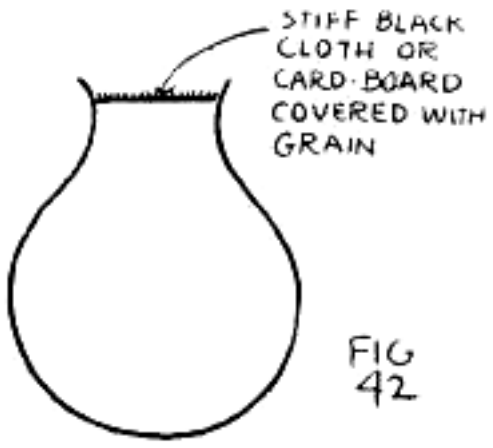


Figure 42.

(38-13)

2 -- A box of grain.

3 -- An 18-inch square of opaque cloth to cover jar.

SECRET:

To Perform:

Just before performing experiment, place a handful or so of grain from the box on top of prepared jar to give appearance that grain is heaped high on jar.

Prepared jar, box of grain, and cloth are brought in.

Turning mouth of jar away from audience, pour out the excess of grain into the box, or just brush excess off with hand. Show mouth of jar to audience now to convince them that jar is filled with grain.

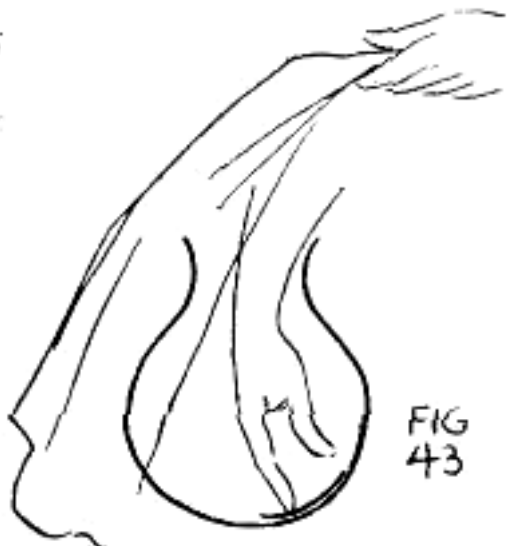


FIG
43

Place jar on a table top, under which audience can see, or on seat of a chair. Cover jar with the cloth. While you are doing this, screen right hand with cloth and reach down into jar. Push fake top down and reverse it so that it rests on bottom of jar with black side up. As inside of jar is black, this piece of black cloth will not be visible when jar is shown.

Figure 43.

If you desire, you may place a piece of conjurer's wax in bottom of jar to which fake top may be fastened when pushed down.



FIG 44

After jar has been completely covered with cloth, suddenly whisk away cloth and show jar empty.

Figure 44.

* * * * *

THE PRODUCTIVE JAPANESE LANTERN

EFFECT:

A square Japanese lantern with removable top is shown empty. Top is replaced and then removed again. Magician reaches in and produces five or six smaller Japanese lanterns which he hangs on a bamboo pole or string stretched across the stage. He then produces yards of brightly colored paper ribbon and a variety of colored silk handkerchiefs. If desired, silks may be gathered up and rabbit produced from them, or a large six-foot silk with a butterfly, peacock, parrot, or Chinese figures painted on it.

PARAPHERNALIA:

1 -- A square decorated Japanese lantern with removable top. I teach you how to construct this lantern, though you

might be able to purchase a similar one already made at a Japanese store or large department store.

The size of the lantern will vary with the size of the load you wish to produce from it. First determine the size of your load and then construct the lantern to fit.



FIG
45

Make four squares of wood, cardboard, or metal for the sides of the lantern, decorated in some manner to suggest Japanese design. Make the frame around edges of wood. Hinge the frames together. Make your top of thin wood, painted gloss black.

Figure 45.

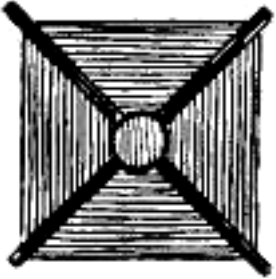


FIG
46

Figures 46 and 47 show construction of top inside and outside. Join four triangular pieces of the wood with cross pieces to hold them. Place a round piece at the top to finish it.

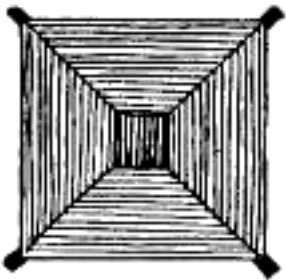


FIG
47



FIG
48

The lantern may have a bottom which is hinged to one side so that it can be pushed upward into lantern. Bottom may be omitted, and if it is, legs of lantern should also be eliminated so that lantern can rest squarely on table.

Figures 48 and 49.

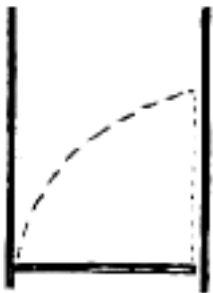


FIG.
49



FIG 50

Be sure to hinge sides of lantern so that it can be folded flat for packing.

Figures 50 and 51.

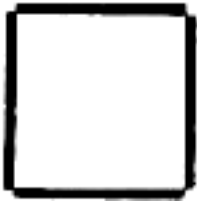
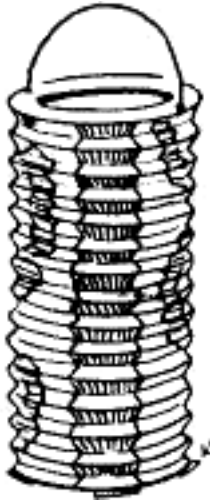


FIG 51



PROJECTING
CARDBOARD
GLUED ON
BOTTOM

FIG 52

2 -- A few Japanese lanterns which are made straight up and down. You can purchase these at a Japanese or novelty store. As the usual Japanese lantern has a wooden top and bottom, it is necessary to remove them and substitute a flat tin top and bottom.

Fig. 52.

(38-15)

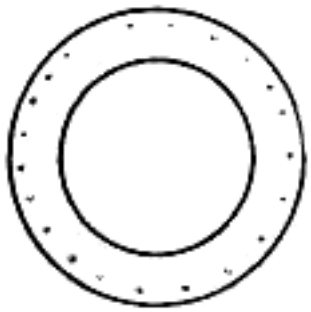


FIG. 53

Have a tinner cut out circles of tin for you with holes punched about one-half to one inch apart so that lantern can be sewed to them.

Figure 53.

Have a wire handle fixed on top of each lantern. Have this hinged so that it will lie flat on lantern when not in use.

3 -- A half-dozen China silk handkerchiefs, from 27 inches to a yard square. Use a variety of colors.

4 -- A black silk handkerchief.

5 -- A roll of bright-colored paper ribbon. We can supply you with this ribbon, or you may buy it from almost any magical supply house.

SECRET:

To Prepare:

Build your lantern as directed. Prepare your smaller lanterns.

THE LOAD:

Fold up the silks carefully and place them on top of the roll of paper ribbon. On the silks, place the five or six folded lanterns. Around all this wrap the black silk handkerchief tightly and pin it so that it will hold. Stick pin in at edge so that around middle part of pin a heavy black thread may be tied. To free end of thread, attach a snap fastener.

Figure 54.

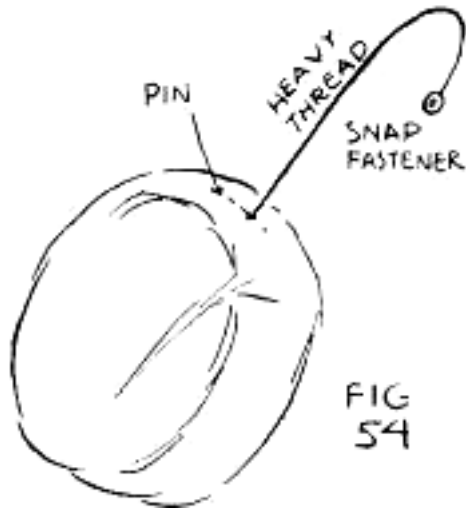


FIG 54

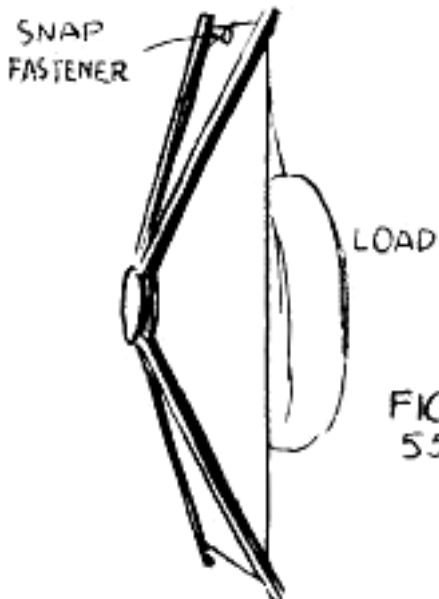


FIG 55

Place second half of snap fastener on top of one side of cover of lantern. Attach fastener on thread from load to lantern top so that load comes inside of top.

Figures 55 and 56.

Place load carefully in lantern and push top a bit forward. Snap fastener is at rear edge. Place lantern thus prepared on seat of a chair in readiness for experiment.

(38-16)

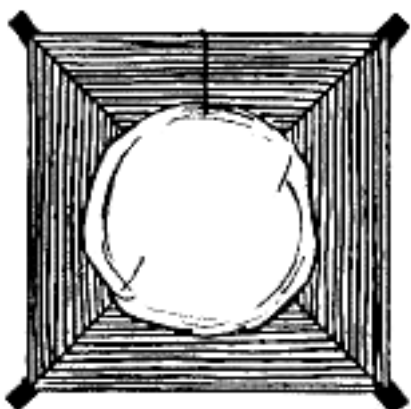


FIG 56

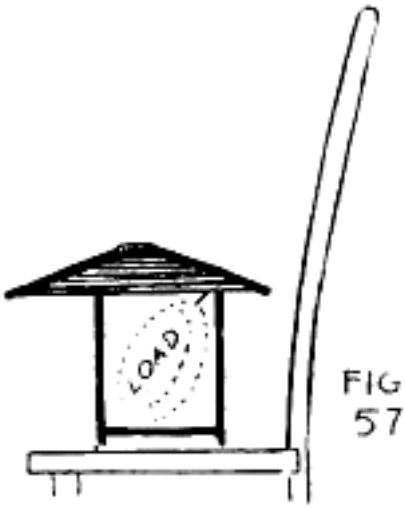


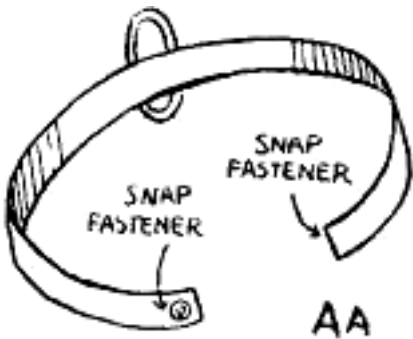
Figure 57.

If you desire to produce a rabbit from the silks or ribbon, prepare a rabbit bag to hang on back of chair. Cover front of chair with decorated cloth to screen rabbit bag. See Lesson 30 for this rabbit production.

If you desire to produce a large silk, prepare it in this manner:

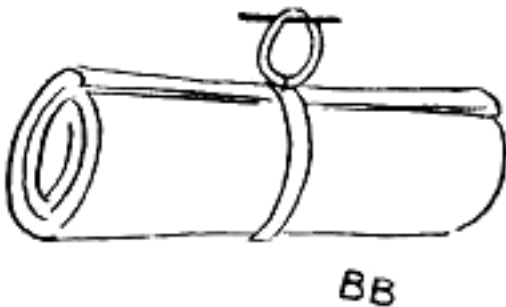
The silk should be about five or six feet square. Paint a brilliant butterfly, peacock, parrot, or Chinese figure on it with Paintex or oil or Japanese colors mixed with Permanent mixture to keep them from running.

Sew a white button to right-hand upper corner of silk and a black button to upper left-hand corner. In this way when you remove silk from back of chair, you can grasp white button in right hand and black button in left hand and open silk out properly to display the figure painted on it.



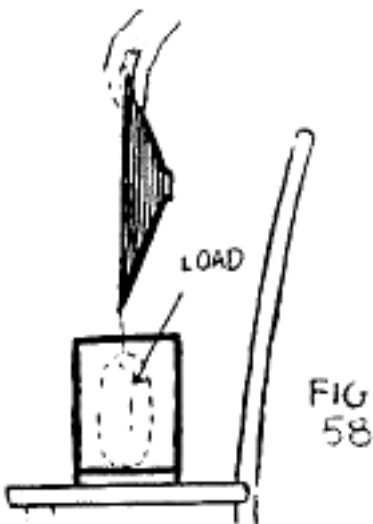
Roll up the silk and place it in special fastener. To make fastener, take a piece of tape and sew half of a snap fastener to each end. Sew a small metal ring to middle.

Figure AA.



Place fastener around middle of silk and snap together. Hang metal ring on nail at back of chair.

Figure BB.



To Perform:

Lift lid by front edge and show inside of it. Be careful not to lift load above top of lantern. The thread connecting lid and load will not be visible.

Figure 58.

Replace lid, then lift up whole lantern and show all sides of it.

Lift rear side of lid, drawing load up behind it.

Figure 59.

Place lid against chair with load concealed, or give to assistant to hold. Show lantern empty.

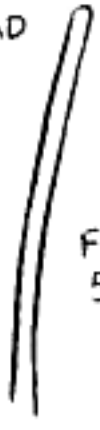
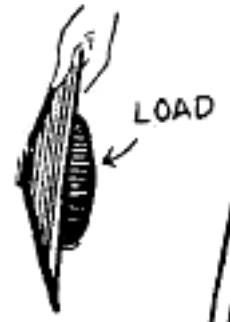


FIG
59

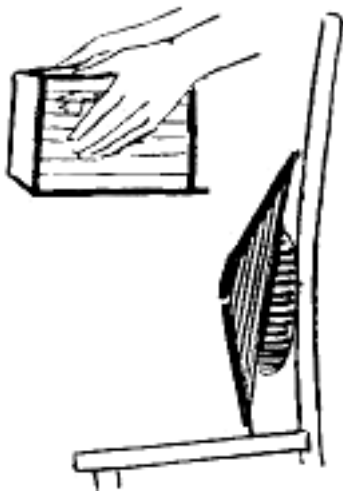


FIG
60

Figure 60.

If lantern has bottom, push bottom in and fold lantern up flat to show that there is nothing in it.

See Figure 50.

Open lantern again and place bottom in position. Replace lantern on chair seat. Pick up top and place front edge down on lantern first, allowing load to fall into lantern and then dropping rear edge. Release snap fastener, permitting load to sink down on to bottom of lantern.

Reach up with right hand into the air. Pretend to grasp something and toss it toward lantern. Repeat this motion again.

Remove top of lantern and place against chair. Unpin black silk around load quickly. Tuck silk down or remove it and place over back of chair.



FIG
61

Now reach in and grasp top lantern by handle. Pull it out, pushing projecting cardboard at bottom against big lantern to open it.

Figure 61.

Have cord stretched across stage on which to hang lanterns. Or even more effective, have assistant carry a bamboo pole over his shoulder. As you produce the lanterns, hang three on one end of pole, have assistant turn and hang three lanterns on other end.

After lanterns are produced, reach in and take out the silks one at a time. Open them out wide and place them over back of chair.



FIG
62

Take out end of paper ribbon in center of roll while roll is still inside of lantern.

Figure 62.

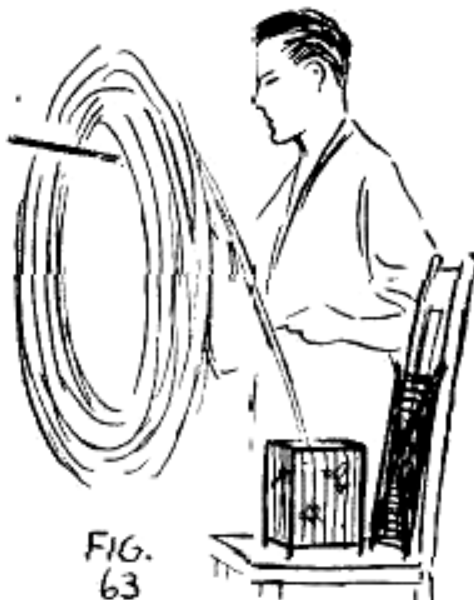
Put your wand through center of roll and unwind ribbon by rolling it around in a large circle on your wand. This is very effective.

Figure 63.

This ribbon may be placed over back of chair. If you produce a rabbit as a finish, gather up the silks and mass of ribbon and with it the rabbit bag and rabbit. Produce the rabbit.

If you are producing a large silk for a final flash, let the paper ribbon drop to floor and pick up the silks from back of chair with large silk from behind chair. Give assistant the silk to open up or drop other silks and open large one yourself.

The lantern is easily prepared and makes a flashy production when properly dressed. It utilizes a principle which we have discussed before. It is one of the most valuable loading principles to know.



Harlan Tarbell

TARBELL SYSTEM, INCORPORATED, Chicago.

* * * * *

LESSON 39

More interesting Handkerchief Magic. You have already had some work with handkerchiefs, but there are other angles which you should know. You learn them in the next lesson. I am eager to send it to you because I know you will be very glad to have it.

* * * * *

MORE HANDKERCHIEF MAGIC

This lesson gives you a greater knowledge of Handkerchief Magic. I have given you many principles for use with handkerchiefs. Remember that this has been my aim in the course--to teach you principles, the fundamentals, the SCIENCE of Magic. I wanted you to know, not just a number of tricks, but the framework on which the whole art is built. And so with Handkerchief Magic, I have taught you the foundation in as simple a manner as I could. The elaborations, the trimmings, are up to you to work out according to your own individuality.

In this lesson are included experiments which have won their way into some of the finest magical programs. They are very effective and yet I have made them easy to construct and inexpensive. They can, however, be enlarged upon and elaborated into flashy and expensive stage effects if the performer desires.

THE HANDKERCHIEF BALL

This is a mystifying way of vanishing and producing from one to four silk handkerchiefs in the hands.

EFFECT:

Performer's sleeves are rolled up to the elbow. He picks up a handkerchief, rolls it up between his hands, and it suddenly vanishes. Magician shows both sides of hands empty. Then he suddenly pulls out the silk. This is continued with several handkerchiefs.

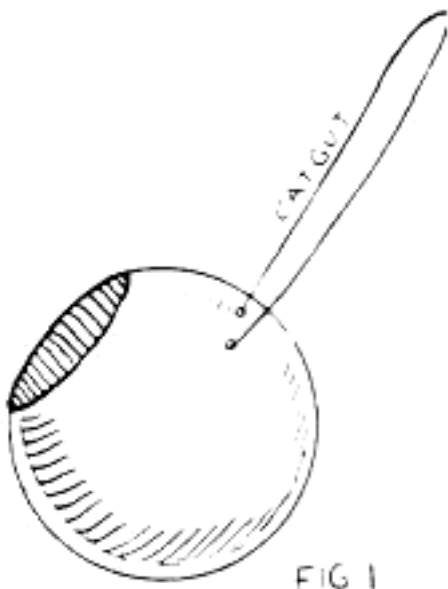
PARAPHERNALIA:

1--A Handkerchief Ball.

We sent you a Ball FREE with your outfit.

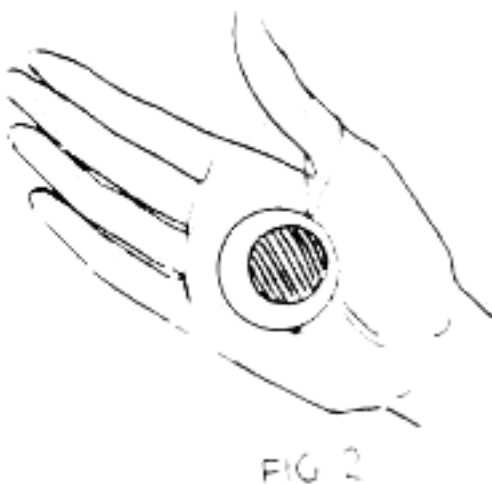
The Ball is made of thin brass or aluminum. It is about 1 3/4 inches in diameter with an opening in one side a little over an inch in diameter. At the top of the Ball are two small holes through which a thin piece of catgut (or fine white thread) is threaded.

Figure 1.



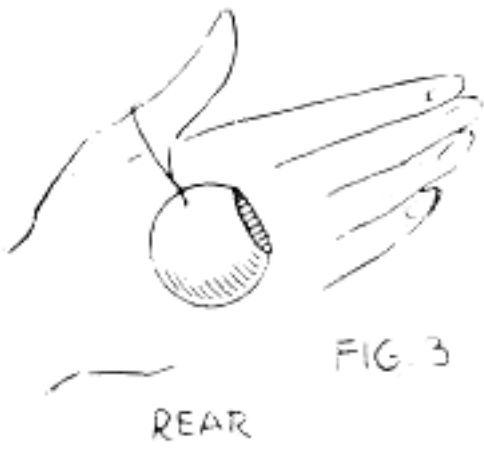
The size of the catgut loop depends on size of performer's hand. It should be the proper length so that when Ball is suspended from right thumb, Ball comes to middle of palm.

Figure 2.



When Ball hangs on back of hand, it should be in position shown in Figure 3.

(39-1)



MODUS OPERANDI:

Sleeves may be rolled up to elbow or not, as you wish.

Have Ball under a handkerchief on table, or have both Ball and handkerchief in your right coat pocket.



Pick up handkerchief with Ball concealed. Secretly slip right thumb through catgut loop. Turn right side toward audience. Hold handkerchief suspended from left hand and point at it with right hand. Ball is concealed in palm of right hand.

Figure 4 shows view away from audience.



Open right fingers and bring right hand to middle of handkerchief. Hold both hands parallel and with rotary motion tuck handkerchief into Ball in right hand. Keep back of right hand to audience.

Figure 5.

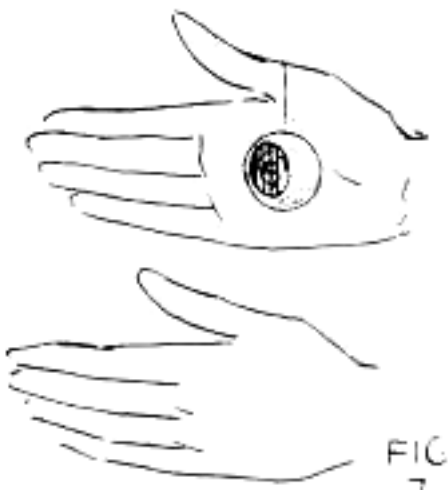


As soon as handkerchief is fully concealed in the Ball, close left hand as if you had tucked handkerchief into it and bring hand a few inches away from right. Spread right fingers wide apart to show nothing concealed. The catgut or fine white thread is not visible to audience.

Figure 6.

Point at left hand gracefully with right forefinger and slowly open left hand to show that handkerchief has vanished.

To Show Both Hands Empty by Showing Both Sides of Each:



Bring right hand above left, still keeping back of it to audience.

Figure 7 shows view away from audience.

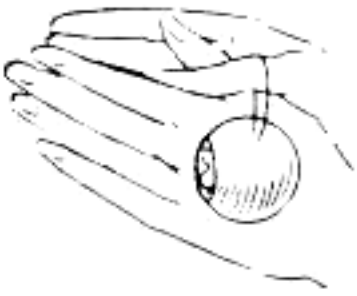


FIG. 8

Lower right hand, allowing Ball to drop down behind left hand.

Figure 8 shows view away from audience.



FIG. 9

Keep thumbs of both hands crossed and raise right hand so that palms of both hands are now exposed.

Figure 9 is a view away from audience.

(39-2)



Figure 10 shows hands as audience sees them. Ball is concealed behind left hand.

Bring right hand down to position shown in Figure 8 and separate hands as in Figure 7. Now turn left hand so that backs of both hands are exposed. You have now shown backs and fronts of both hands.



Bring left hand up against right, keeping your fingers close together and curled inward slightly.

Figure 11.



Turn your body to the right so that left side is now toward audience.

Keep thumbs crossed and raise right hand to show backs of both hands together. Ball hangs concealed in left palm.

Figures 12 and 13.



Curve right fingers inward and bring them down in back of Ball.

Figures 14 and 15.

FIG 14

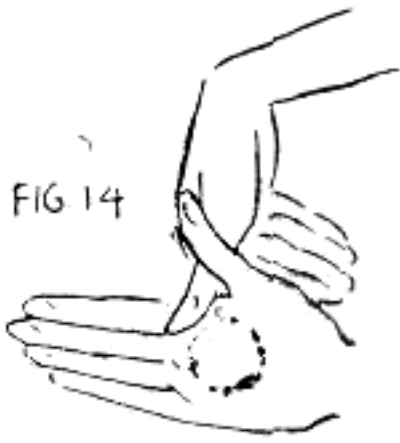


FIG 15



Straighten right hand and Ball comes on back of right hand.

Figure 16.



FIG 16

Draw left hand aside and turn it over to show palm. Spread fingers wide apart as you expose palms of both hands.

Figure 17.



FIG 17



To Produce Silk--

Reverse routine of movements, starting with Figure 16 and working back through to Figure 5. Produce silk by pulling it out of Ball with left hand. Hold it out between both hands.

Figure 18.

To Vanish Three Silks at Once--

Vanish first silk in Ball and show both sides of hands as taught to you above up to Figure 10. Do not turn your body.

Pick up the next silk and vanish it in similar manner, and then vanish the third silk the same way. Turn left side to audience and work up to step shown in Figure 17.

Now for production of the three silks, work back from Figure 17 to Figure 5 and produce them one at a time as in Figure 18. As each silk is produced, place it over left forearm. Get rid of Ball by placing it on table under the three silks or placing it in pocket with silks.

Stillwell, the Magician, varied this effect by placing a number of these Balls loaded with silks around his stage where he could get at them easily. He then produced many silks from his empty hands and finished with a production of larger silks from the smaller ones.

* * * * *

THE SOUP PLATE AND HANDKERCHIEFS

This experiment was a favorite of Beautier DeKolta, a famous Magician of days gone by. To DeKolta's original version, Servais LeRoy, prominent Magician, added interesting "wrinkles" and used the experiment on his programs for a long time. A number of years ago, Eugene Laurant, another light in the Magic world, became fascinated with LeRoy's clever handling of the soup plate and handkerchiefs. He varied the effect a little and added it to his program, where it has been a popular number ever since. Almost every modern Magician has had this interesting effect in one of its many versions in his repertoire.

EFFECT:

Performer places a piece of folded newspaper on seat of a chair and on this an empty soup plate, bottom up. He picks up two silk handkerchiefs, rolls them up in his hands, and causes them to vanish. Suddenly he lifts up the soup plate--and there, under it, are the two handkerchiefs.

PARAPHERNALIA:

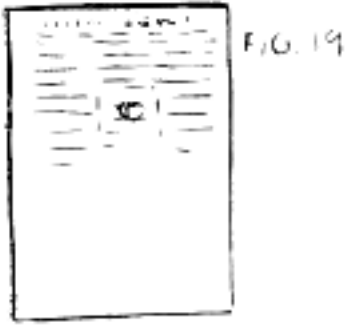
- 1--A double sheet of newspaper.
- 2--A soup plate or dinner plate.

3--Four silk handkerchiefs--two red and two green or two white and two red.

4--Handkerchief Ball.

5--A dining room chair.

SECRET:



To Prepare:

Fold the double sheet of newspaper over in its regular crease.

Figure 19.



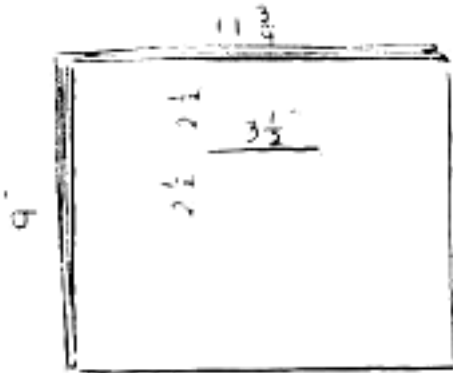
Fold paper in half again, crosswise.

Figure 20.



Fold paper over from right to left.

Figure 21.



On one side of paper cut a slit about 3 1/2 inches long and 2 1/2 inches from the top of paper. Cut the slit only through the top two pages. Put some paste between these two pages just below the slit and press them firmly together. Now run a line of paste between the second and third sheets as indicated by dotted line in diagram. This line should run about 2 1/2 inches down from slit. Press second and third pages firmly together and let paste dry. You now have a pocket to hold silks.

Figure 22.



Take one red and one white handkerchief and place them together, holding them by one corner. Fold up handkerchiefs as shown in Figure 23.



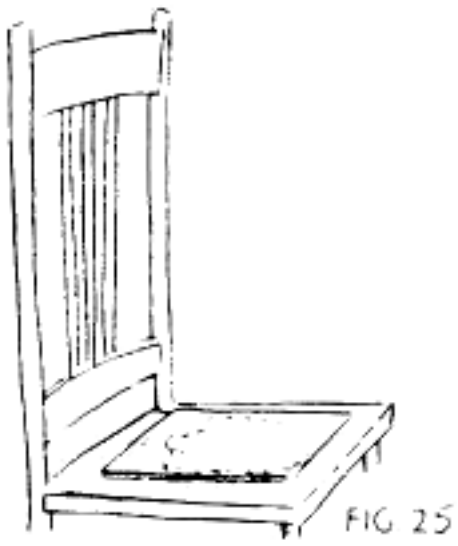
Place folded silks in pocket of newspaper with outer ends at bottom of pocket to hold them securely. Part of the silks protrudes from pocket.

Figure 24.

Place the newspaper with silks down on the plate and place plate on seat of the chair or on table.

Figure 25.

(39-5)



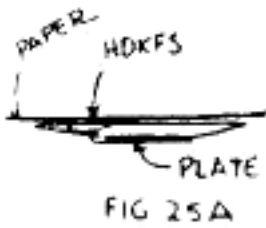


Figure 25A is a diagram of the arrangement of plate, handkerchiefs, and newspaper.

Have duplicate red and white silks on table with Handkerchief Ball under them—or silks may be hanging on back of chair and Ball concealed in right coat pocket.

To Perform:

Pick up newspaper from plate with left hand, thumb in front and fingers in back to hold silks.

Figure 26.

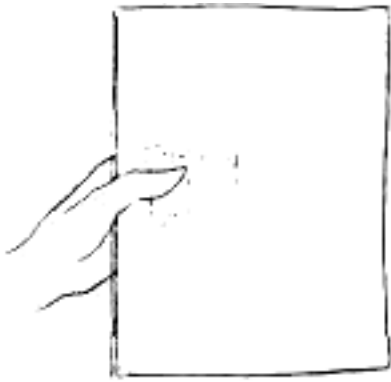
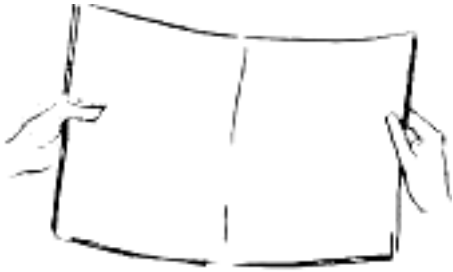


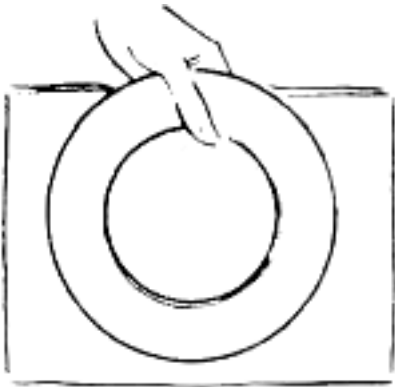
FIG. 26



Unfold newspaper to show inside, proving to audience that you hold just an ordinary newspaper. Be careful to conceal back of paper with silks.

Figure 27.

FIG 27

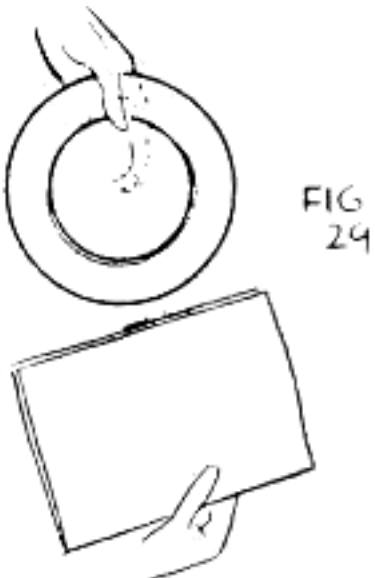


Fold paper up again. Pick up plate in right hand and show both sides of it. Now place plate in left hand with top against paper.

Figure 28.

Brush right hand across seat of chair to show there is nothing on it.

FIG 28



Grasp bottom of newspaper with right hand and remove it from left, leaving the silks and plate in left hand.

Figure 29.

FIG 29

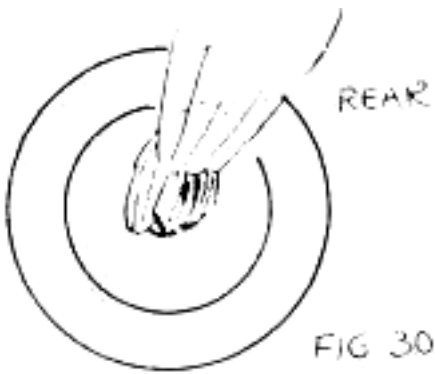
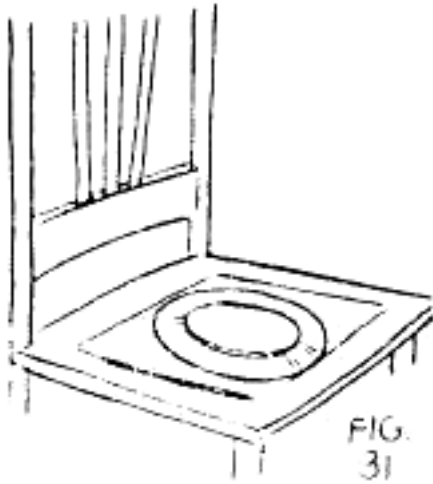


Figure 30 is view away from audience. It is very easy for you to slip silks from newspaper with fingers of left hand as you draw paper away with right. Silks are now inside of plate.



Place newspaper on chair-seat and on this, place the plate, top down. Be very careful in placing plate down not to expose the silks. Put edge toward audience down first and this will conceal silks.

Figure 31.

Now pick up the two duplicate silks and concealed Handkerchief Ball. Hang Ball on right thumb. Hold silks by corner as in Figure 4. Bring hands together and then expose palms as in Figure 9. Bring hands back to position shown in Figure 7 and then tuck silks into Ball as in Figure 5. When silks are in Ball, continue the first part of vanish up to Figure 10, then return to position of Figure 7.

(39-6)



FIG. 32

Figure 32 shows your position as you vanish the silks.



FIG. 33

Pick up plate with left hand, showing the sudden appearance of the silks under the plate on newspaper.

Figure 33.

Pick up silks, one at a time, with right hand. Dispose of Ball by concealing it in the silks and placing them on table or reach for some article in your pocket and leave Ball there.

* * * * *

TWO SOUP PLATES AND HANDKERCHIEFS

In this version, two plates are used and no newspaper.

EFFECT:

Performer shows two empty plates, puts the two tops together and places them on table. He vanishes two silks in his hands and makes them appear between the two plates.

PARAPHERNALIA:

- 1--Two soup or dinner plates, the same size.
- 2--Four silk handkerchiefs, two red and two white.
- 3--Handkerchief Ball.

SECRET:

To Prepare:

Fold two handkerchiefs as in Figure 23.



FIG. 34

SILKS

Place one plate at rear edge of table, top down with part of it extending over table. Under edge of plate, place the two folded handkerchiefs, with edges tucked securely under plate.

Figure 34.

Place the second plate on first one.

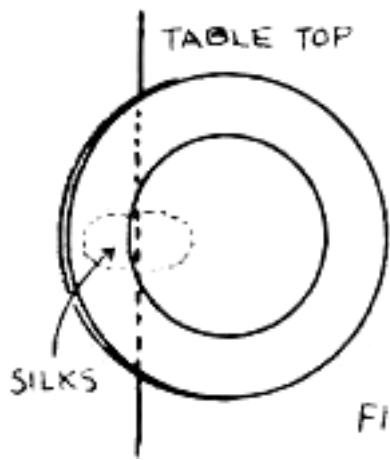


FIG 35

Figure 35 shows arrangement of plates and silks on table as seen from above.

Have duplicate silks and concealed Ball nearby on table.

To Perform:

With left hand pick up the two plates with silks concealed inside of them.

(39-7)

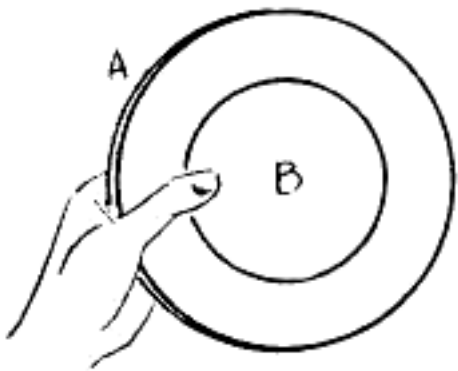


FIG. 36

Figure 36.

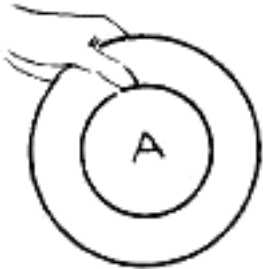


FIG 37

Remove top plate with right hand and show both sides of it.

Figure 37.

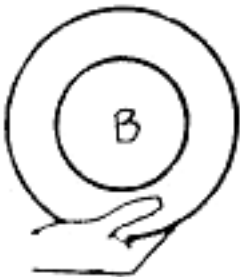
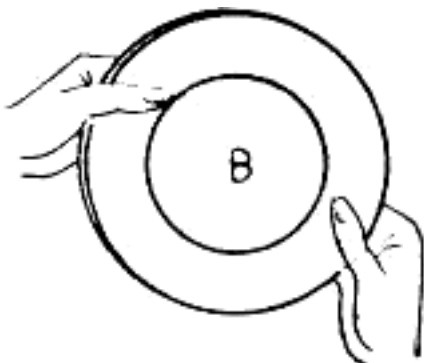


FIG. 38

Replace top plate on lower one again, and at the same time, draw away lower plate with right hand. As you do so, leave silks inside of top plate, grasped in left hand.

Figure 38.



Show second plate on both sides and place it top up on table. Now place other plate top down on this one. Place outer edge down first to conceal silks.

Figure 39.

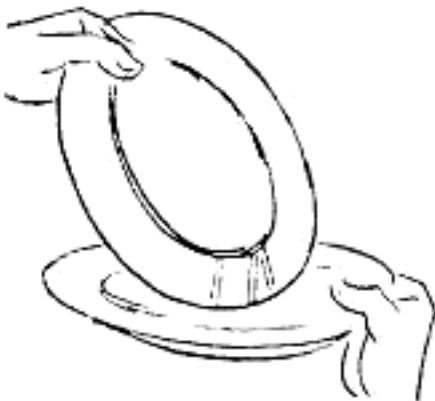


FIG 39

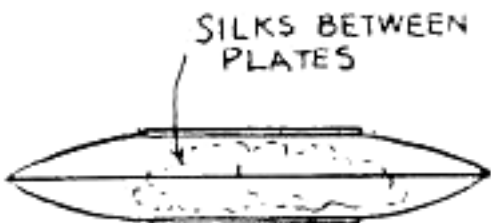


FIG 40

When the two plates are together, the silks are between them. To the audience it appears, however, that you merely placed two empty plates together.

Figure 40.

Pick up duplicate silks and Handkerchief Ball. Vanish silks as you have been taught to do. Then separate the two plates and show that silks have appeared between them.

Place silks on table, concealing Ball in them.

* * * * *

or

The Little Glass House by the Sea

The effect in which a silk handkerchief is vanished and is then found tied between two other handkerchiefs has become a standard effect. The modern, simplified method has served to make it even more popular than ever.

(39-8)

EFFECT:

Two silks are knotted together and placed in a glass tumbler. Another silk is vanished. The two silks are suddenly jerked out of the glass and the vanished silk is found tied between them.

This experiment is usually worked by tying a red and blue silk together and causing a vanished American flag to appear between them. An interesting variation may be performed with the English Union Jack, the Red Cross flag, and the Irish flag, especially if patter is used.

PARAPHERNALIA:

1--Two English Union Jack flags, 12x18 inches.

2--An Irish flag, 12x18 inches.

3--Two Red Cross flags, 16x22 inches.

4--A Handkerchief Ball, Handkerchief Pull, or some other device for vanishing a silk.

5--A glass tumbler and a glass of water.

We can supply you with flags at the usual market prices.

SECRET AND PATTERN:

To Prepare:

Take a piece of dark blue silk, 3 1/2 inches long by 3/4 of an inch wide. Sew one end to one of the Union Jacks, leaving about 3/4 of an inch between stitching and edge of flag.

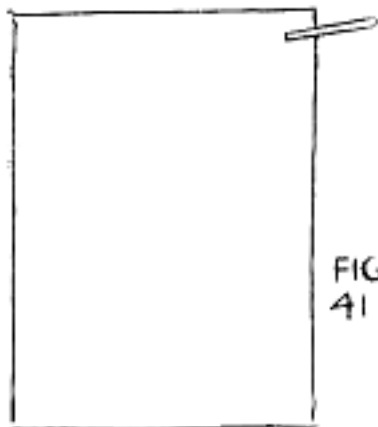


Figure 41.

Place the duplicate Union Jack on this prepared one and sew all around the edges, leaving a space about five inches long at upper right edge. The small piece of silk extends from this opening.

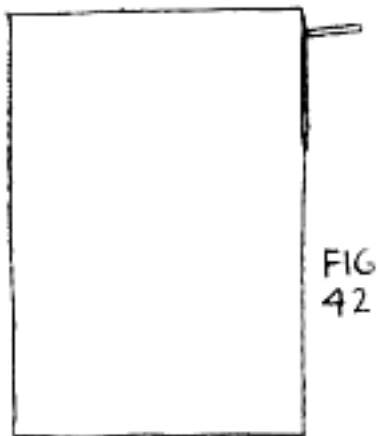
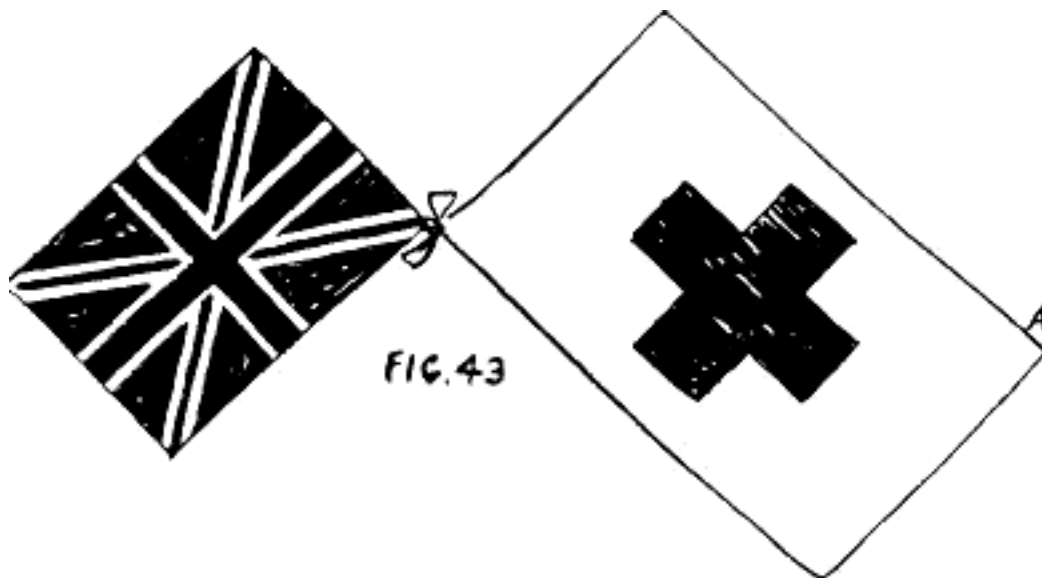


Figure 42.



To this small tab of silk, tie a corner of the Red Cross flag.

Figure 43.

Tuck the Red Cross flag between the two Union Jacks, leaving corner A out about an inch.

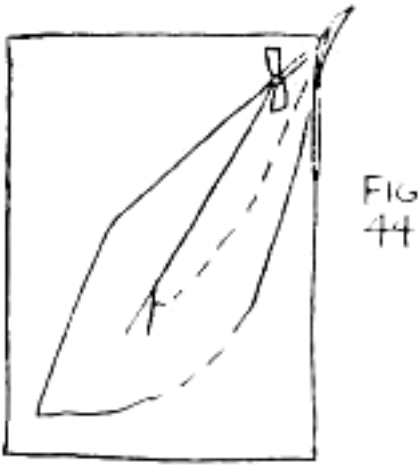
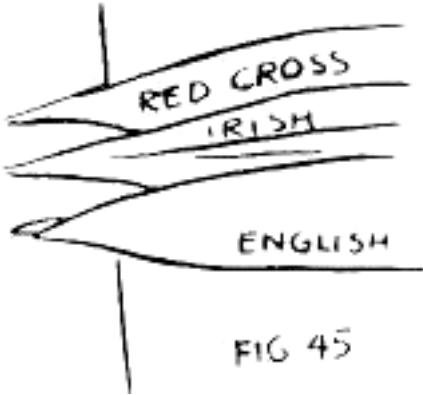


Figure 44.



Place prepared silks on table, with prepared end extending over rear edge of table. Arrange the duplicate Red Cross flag and the Irish flag as in Figure 45.

Place glass tumbler and glass of water nearby.

To Perform:

Stand to right of table.

"I take pleasure in presenting that famous four act drama, entitled, 'The Little Glass House by the Sea.' "

Pick up the glass tumbler with right hand and show.

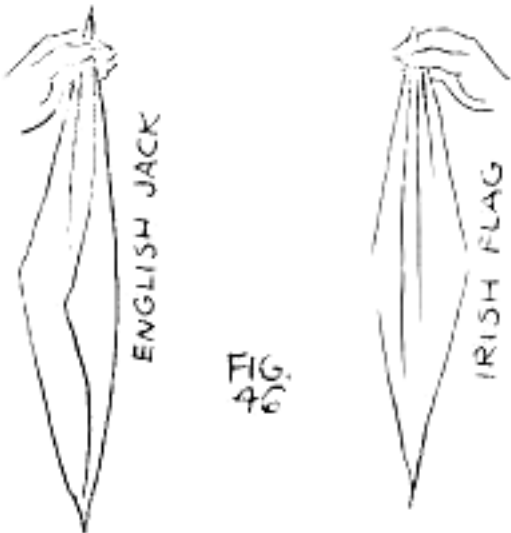
"This is the little glass house."

Wiggle left fingers in water of other glass to show that glass contains water.

"And this is the sea."

Place tumbler down near glass of water.

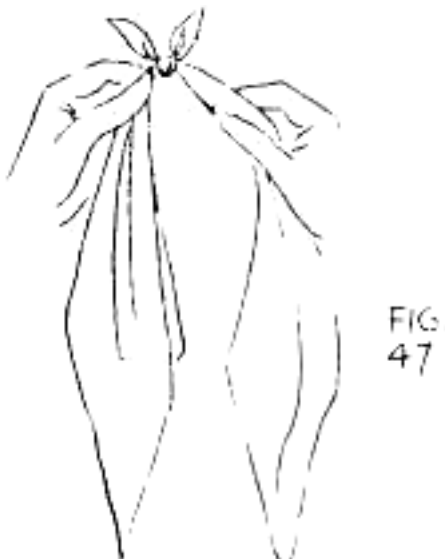
"So we have the little glass house by the sea."



Pick up the Union Jack with left hand, holding thumb over prepared corner. Pick up Irish flag with right hand.

Figure 46.

"We also have a hero and a hero-eeen. The hero was an English Jack, a sailor boy was he; while the hero-eeen was a buxom Irish girl, as sweet as sweet could be. It was love at first sight--anyway, whatever it was, they got married. I will be the minister, perform the wedding ceremony and knot them together."



Apparently tie the two flags together, but really tie the Irish flag to corner A of the Red Cross flag. Cover your movements with left fingers and thumb.

Figure 47.

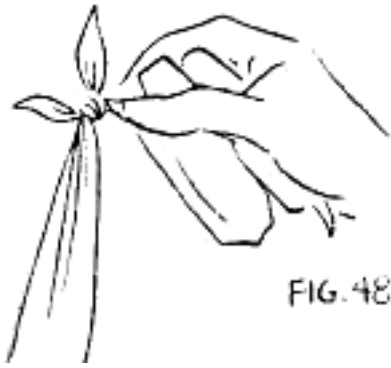


FIG. 48

Grasp Union Jack near bottom with right hand and fold it up in right hand, pleat fashion. Hold flags by the knot with right thumb and fingers. Release hold with left hand, allowing Irish flag to hang suspended from right fingers.

Figure 48.

(39-10)

"It is really around a NOT that this little drama started. If the hero and the hero-een, when asked, 'Do you take this woman to be your lawfully wedded husband?' had said, 'I do NOT,' instead of 'I do,' it is likely that this play would never have been written. A dog and a cat may live peacefully together, but if you tie their tails together and hang them over a clothesline, it isn't so good."



FIG. 49

Roll Irish flag around the Union Jack.

Figure 49.

"Anyway our hero and hero-een, wrapped up in each other with visions of bliss, went to live in the little glass house."



FIG 50

Pick up tumbler and place rolled silks in it, allowing end B of Irish flag to hang out so that you can grasp it easily.

Figure 50.

"By the sea."

Wiggle left fingers in glass of water, then place tumbler down near it.

"So they lived happily together for a long time—say about two days. And that is the end of Act One."

Pick up the Red Cross flag.

"Acts Two, Three and Four. What have we here? The Red Cross. And what, pray tell, is the Red Cross for? Listen, and I shall explain. The Red Cross follows the battles and picks up the wounded. Isn't the Red Cross rather large? Yes, but this is going to be a rather large battle."

Look at silks in glass.

"There is a commotion in the household. They are throwing dishes at each other. Red Cross, do your duty."

Vanish Red Cross flag by any method you wish. You may use a Handkerchief Ball, a Pull, or just vanish the flag in your pocket. If you have used the Ball on your program, it is well to vanish the flag by another method this time.

Show hands empty after vanish.

"It is on its way--it has arrived—and"

Pick up corner B of Irish flag and jerk flags from glass, allowing the Red Cross flag to slip out of the double English flag. Let all three flags hang suspended from right hand and show to audience.

The Red Cross flag has mysteriously appeared between the two flags which audience saw you place in glass.

Figure 51.

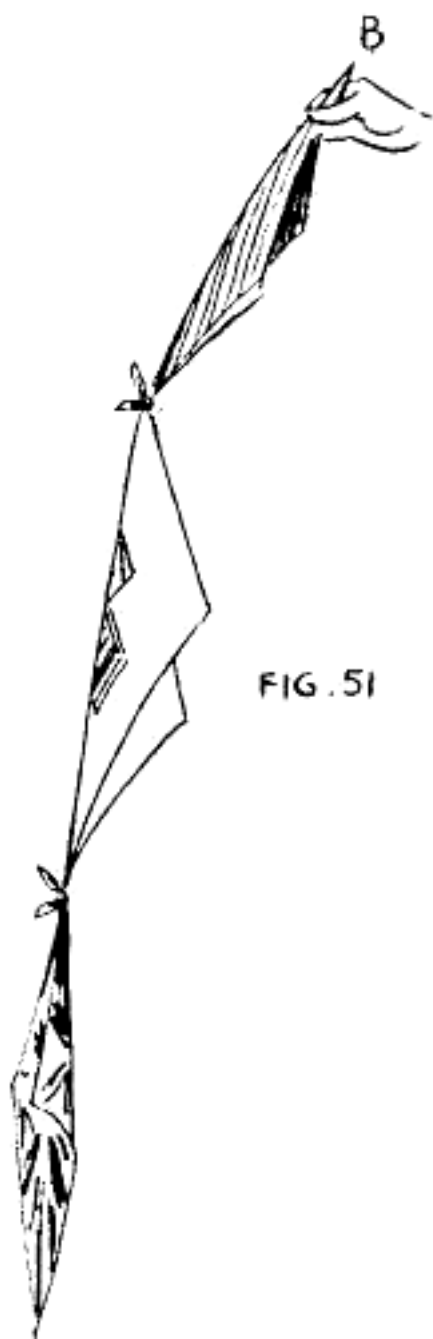


FIG. 51

"It has separated the battling household."

SUGGESTIONS:

This experiment may be worked up with various stories for the patter.

Another angle of the patter presentation is to tell the story of the hero of true blue, using a double blue handkerchief, and the hero-een of blushing red, using a red handkerchief. Then comes the double-dyed villain for which you use a silk of many colors with one blue corner extending out of double blue silk. The hero and hero-een get married and knotted together. Then the villain says, "I shall get between them yet." Jerk out the silks from the glass, after vanishing a duplicate handkerchief for the villain, and show that the villain has come between them.

Here is another comedy version. After placing the two knotted handkerchiefs together in glass, show half a dozen small silks of various colors. Say, "Ah, where are we? We are in heaven. And who are these? Little children looking for a home—Rose, Mike, Jim, Pete, Sally, and Ambrose. Shall we send them down to earth? No sooner said, than done."

Vanish the small silks (duplicates of silks placed inside of double blue handkerchief). Jerk silks out of glass and show that the small silks have appeared between the two large ones which audience saw you place therein.

This experiment is fine for use in silent Oriental acts. The silks can be large with Chinese patterns on them. A large silk with some prominent figure on it can be vanished and then made to appear between the other two silks.

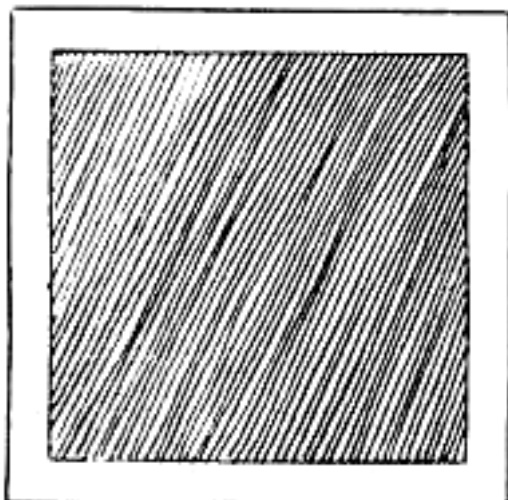


FIG. 52.

Some time ago, Odin, a French Magician, made a great impression by using silks with wide borders. You can work up a good effect by using bright-colored silks, all with white or the same colored borders.

Figure 52.

* * * * *

TARBELL'S COLOR CHANGING HANDKERCHIEF

I brought out this color-changing handkerchief in my early teens, and since then it has been a standard effect in the magician's repertoire. It is self-contained and is easy to work so that it readily became popular. It has been sold by Magic dealers the world over.

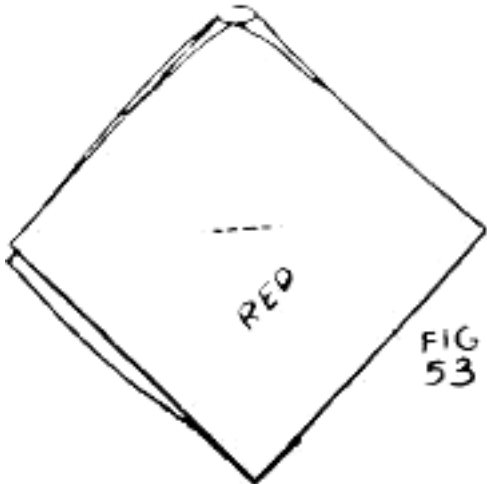
EFFECT:

Performer shows a red handkerchief. He passes his hand over it and it immediately changes to a blue one. Again he passes his hand over it, and it becomes red once more.

PARAPHERNALIA:

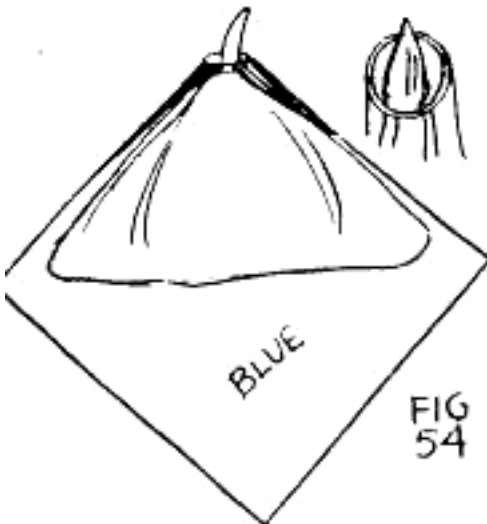
To Construct:

Place a red silk on a blue silk and sew a small metal ring to the top corners of each. Size of ring will vary with size of handkerchiefs. It should be large enough to pass over the silks easily, and yet as small as possible so as not to attract attention. For the usual size of silks, a ring three-fourths of an inch in diameter is suitable.



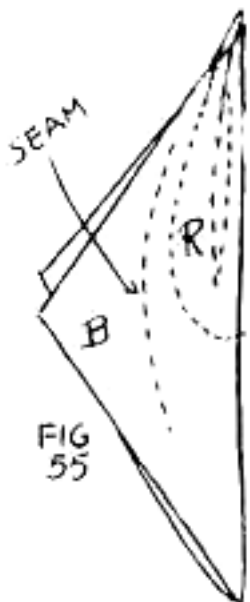
A little above center of handkerchiefs sew about a two-inch line of thread, fastening the two silks together.

Figure 53.



Now take lower corner of top handkerchief and pull it up through ring a little. Be sure to get sewing in proper place so that when handkerchief is folded upward in this way, the corner will extend from ring and can be easily grasped through the ring.

Figure 54.



With red silk folded upward as above, fold blue silk over it lengthwise. Sew the two edges of the blue silk together almost the whole length. This prevents the red handkerchief from being exposed. Place the seam far enough out so that red silk will not bulge out too much but will lie flat.

Figure 55.



Grasp tip of red silk and pull down ring, exposing red silk and concealing blue. Make seam in red silk also, to prevent blue silk from being exposed.

Figure 56.

We can supply color changing handkerchief in pocket size handkerchiefs, finely made.

SECRET:

To Perform:

Show blue handkerchief freely to audience. Grasp tip of red handkerchief in ring with left hand and pull down ring over silk with right hand.

(39-13)

Figure 57.

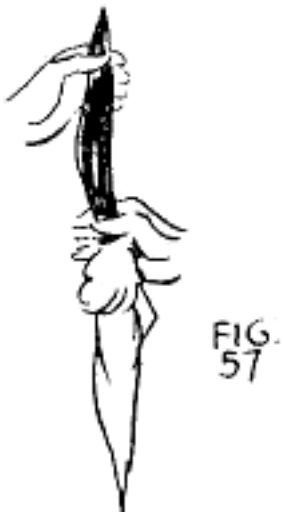


FIG. 57

Your right hand conceals the method of changing the silk, and to the audience it appears that the blue handkerchief becomes red as you pass your hand over it.

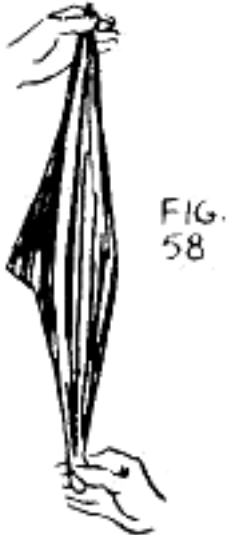


FIG. 58

Figure 58.



FIG. 59

When change is made, shake silk a little in right hand.

Figure 59.

You may use this color-changing silk for a single color change, or turn the silk and restore it to its original color.

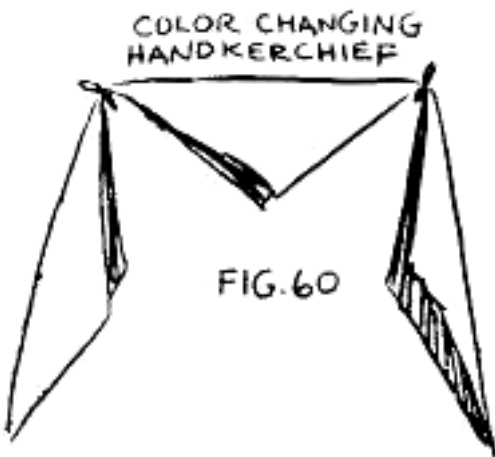


FIG. 60

This device was originally designed for a color change of a silk tied between two others. Instead of a ring, a pliable wire was used which could be bent closed or open at will. The change was most effective.

Figure 60.

I have used this device in connection with the Twentieth Century Silks. I would vanish a red handkerchief and have a blue or green one appear between the silks when they were taken from the glass. Apparently the trick had gone wrong, but I caused them to right themselves by passing my hand over the middle silk and changing its color to red.

NOTE:

The silks used for this device should be opaque so that the inner silk cannot be seen through the outer one. Colored silk pocket handkerchiefs work nicely. You can start by removing a red handkerchief from your upper left coat pocket, saying that red is rather a bright color for a pocket handkerchief. Change the silk to blue and replace it in your pocket.

DOUBLE HANDKERCHIEF COLOR CHANGE

This version, I believe, was brought out by Horace Goldin, another world famous magician.

(39-14)

EFFECT:

Two handkerchiefs, tied together by their corners, change color as Magician passes his hand over them. A yellow and a blue handkerchief, for instance, change to a red and a green one.

PARAPHERNALIA:

To Construct:

Place a green handkerchief on a blue one and sew a metal ring, an inch in diameter, to both upper corners. Also sew lower ends together.

Figure 61.

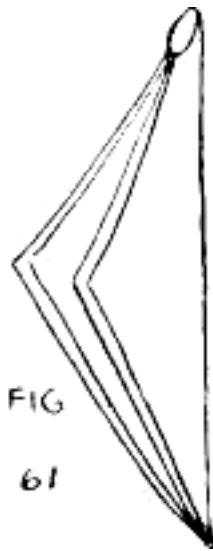
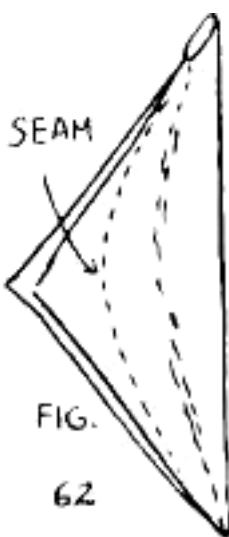


FIG
61

Tuck the green silk well inside of the blue one and sew the two sides of the blue silk together as shown in Figure 62.



SEAM
FIG.
62

Turn silks inside out through ring and make a similar seam in the green silk to conceal the blue one. To end F sew a short strip of green silk to match green handkerchief.

Figure 63.

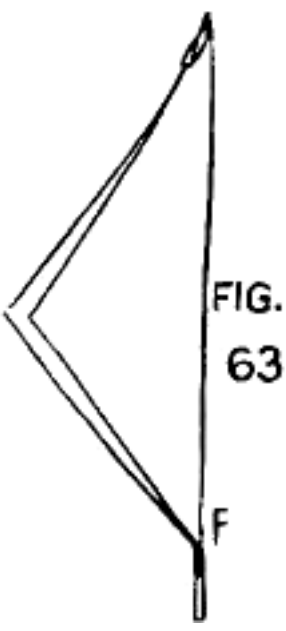
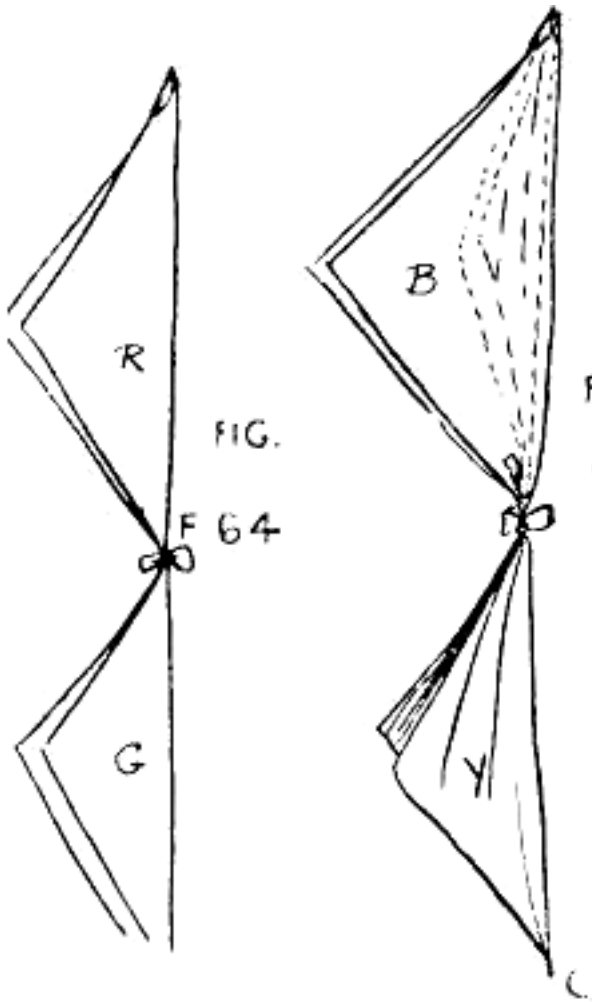


FIG.
63

F

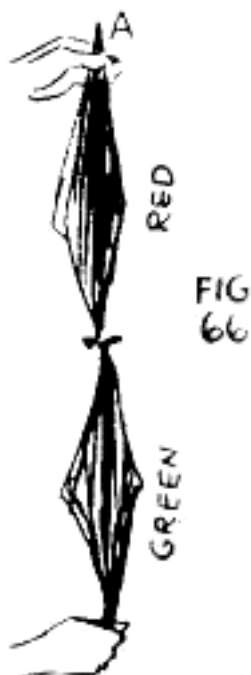


To this strip of green silk, tie a red handkerchief.

Figure 64.

Turn green silk inside through the ring, bringing blue silk outside. Sew a small strip of blue silk to end F of blue handkerchief, and to it tie a yellow handkerchief.

Figure 65.



To Perform:

Grasp red silk through ring at A with left hand and pull ring down with right hand. This turns the blue silk inside and exposes the green one and covers the yellow silk, exposing the red one. The blue and yellow silks have apparently changed to red and green as you passed your hand over them.

Figure 66.

THE DYEING HANDKERCHIEFS

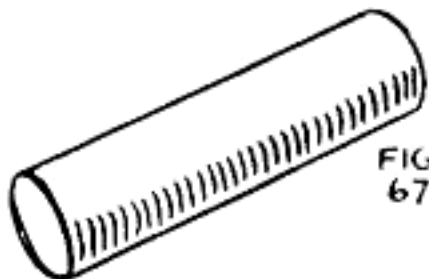
This course would hardly seem complete unless I taught you this favorite magical effect of dyeing handkerchiefs in a paper tube.

EFFECT:

Performer shows a sheet of paper and makes a tube from it. He pushes a white silk through tube to show that it is empty. Again he pushes the white silk through the tube, and it comes out of the other end dyed pink. Stating that the dyeing process is a little too weak, he puts the pink silk through the tube and brings it out of the other end a bright red. Magician then picks up two more white silks, which he puts through the tube, one at a time. The first comes out green and the second one blue. The tube is then unrolled and shown empty.

PARAPHERNALIA:

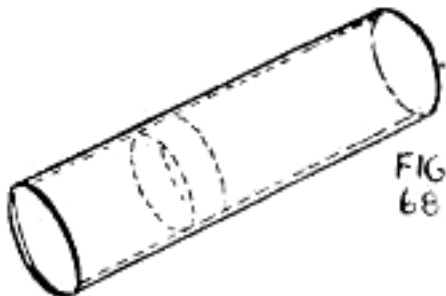
- 1--Eight silks, about 13 inches square.
 - Four white, one pink, one red, one green, one blue.
- 2--A sheet of opaque paper, about 8 1/2 x 12 inches.
- 3--A special metal Dye Tube.



This is a brass tube, 4 inches long x 1 1/4 inches in diameter. Inside of tube is a small cup which slides from end to end. Turned in edges of tube keep cup from pulling out of tube.

Figures 67 and 68.

We can supply you with tube at reasonable price.

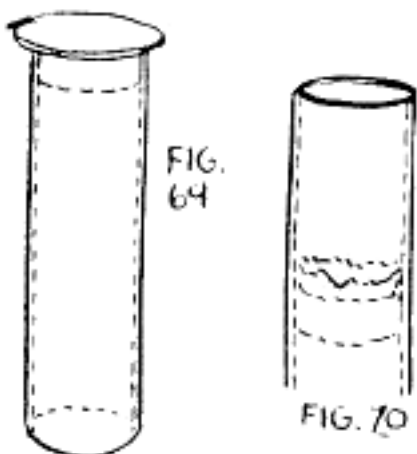


When you receive your tube, cut out a round piece of thin felt a little larger than end of tube. Glue this to bottom of sliding cup in tube.

Figure 69.

When cup is pushed down into tube, edges of circle of felt ripple around inside of tube.

Figure 70.



The purpose of the felt is to keep silks from catching against edge of metal cup when it is pushed up. Tubes supplied by most dealers do not have the felt. You must add this yourself.

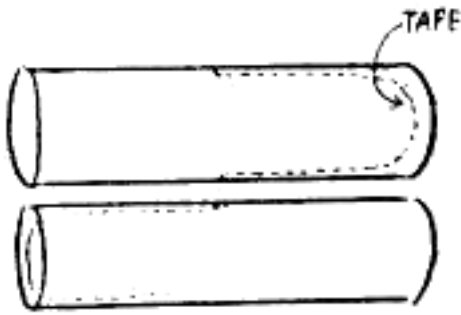


FIG. 71

An emergency tube may be made this way: Make a small cardboard tube. Sew a piece of tape to the middle of each side. Loop of tape should reach from middle to near the end of the tube. This piece of tape can then be moved from end to end. The object of tape is to keep white handkerchiefs pushed in one end of tube from coming out of the other end.

Figure 71.

4--A Servante for catching tube.

In Magic, a Servante is some form of bag attached to a table or chair, into which small articles can be dropped to conceal them from audience. The Servante is, of course, hidden from view, too, behind a drape, a table cover, or chair back.

An inexpensive Servante for use in this effect may be made from a sheet of heavy wrapping paper, a piece of cardboard, and a piece of cloth.

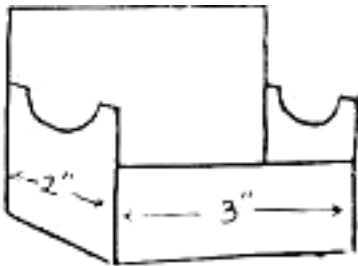


FIG. 72

Make a bottomless box of the cardboard as shown in Figure 72. Make the width two inches and the length three inches.

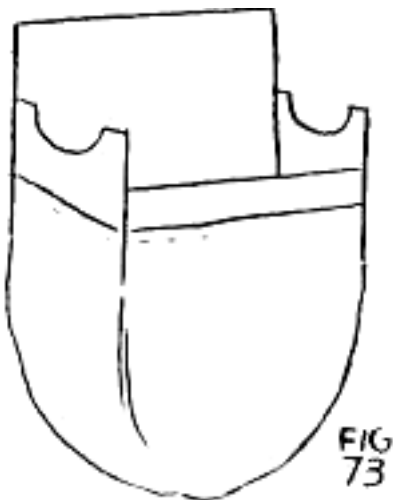


FIG 73

Sew a piece of cloth to the cardboard to form a bag at the bottom.

Figure 73.

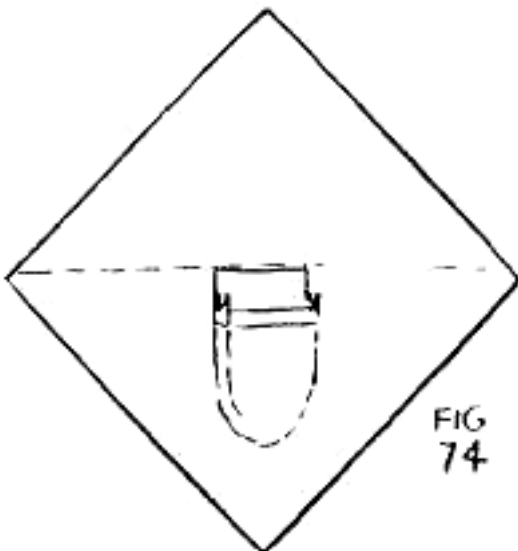


FIG 74

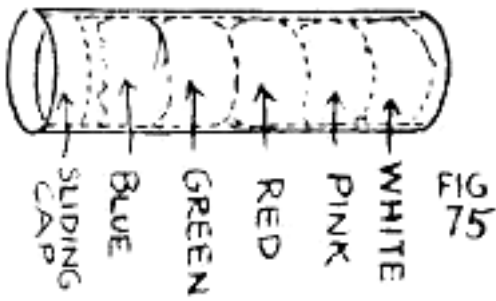
Crease the sheet of wrapping paper diagonally across the middle. Glue back of cardboard box just below middle crease.

Figure 74.

This type of Servante will fold down flat for packing.

This Servante can be used on a card table without any drapes or table cover.

SECRET AND PATTEN:

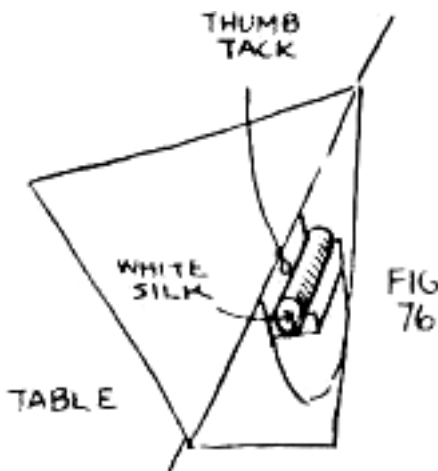


To Prepare:

Tuck five of the silks into the tube next to the felt side of sliding cup. First, tuck in center of handkerchiefs, then the ends. Put silks in tube in this order: blue, green, red, pink, white.

Figure 75.

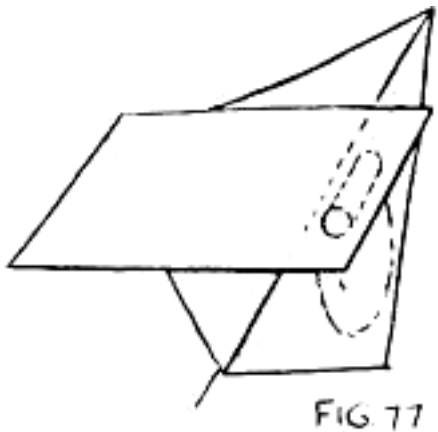
(39-17)



If using a card table, place the Servante at the rear edge with top half of paper on top of table and rest hanging down. Tack cardboard to table edge with thumb-tack. Place the loaded tube across the groove of the cardboard box with white silk end toward your left.

Figure 76.

To the audience it looks as though you merely placed a piece of paper on the table and that one end of it is hanging over. Two sheets of paper may be used. Sheets of newspaper may be used for attaching the Servante, also.



Place the sheet of 8 x 12 paper on table to extend over tube as shown in Figure 77.

At one side of paper, place the three white silks.

To Perform:

Pick up sheet of paper and show both sides.

"Some time ago we had a lady visiting up from Paris. As you know, Paris has a reputation for its fashions. Though this lady's wardrobe trunk was small, it was amazing the number of dresses she apparently carried with her. One would seldom see her with the same color dress on twice in succession. One day, my curiosity got the best of me and I asked her about it. She told me that she really had only three dresses with her, but the great variety was secured through a peculiar process of dyeing her dresses various colors at a moment's notice. Let me demonstrate the process on a smaller scale. The dye works revolve around a piece of paper."



Show paper on both sides again, then hold it up in left hand directly in front of you. Reach under your coat with right hand as if you were getting something and pretend to place it back of the paper. Roll paper into tube.

Figure 78.

"She would roll the paper up into a tube—just an EMPTY tube of paper."

Audience murmurs that you placed something in the paper.

"Pardon me, but there seems to be a wave of suspicion going cm around here that the tube is not empty."

Unroll paper and show both sides.

"There you are. I wouldn't fool you for the world. Someone is just seeing things."

Replace paper on table as in Figure 77. Pick up the three white silks.

"These silks will each represent a dress. One—two—three."

Show each silk separately as you count them.

"Three nice white dresses. They are almost as large as some modern day dresses at that."



FIG. 79

Pick up paper again, placing right thumb above paper and fingers below so that you can also lift up the loaded tube of silks under paper.

Figure 79.

How to Show Paper Both Sides and Conceal Tube:

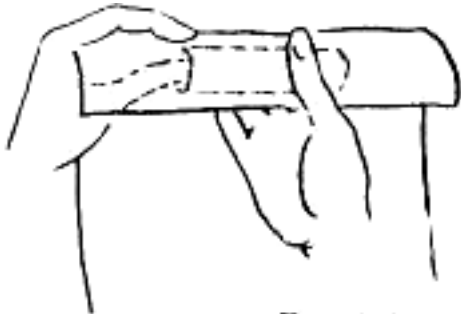


FIG. 80

With right hand bring paper and tube up to left hand. Place left fingers in front of paper and thumb behind into opening of tube.

Figure 80.

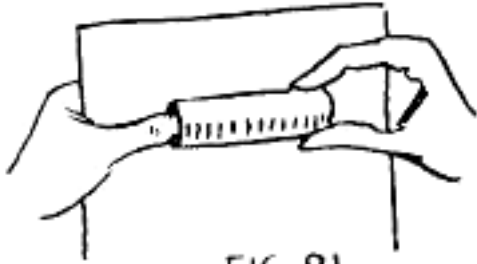


FIG. 81

Release right hand from paper, allowing top edge of paper to fly up. Place thumb and index finger of right hand behind paper and grasp tube. Place the other three fingers in front of paper.

Figure 81.

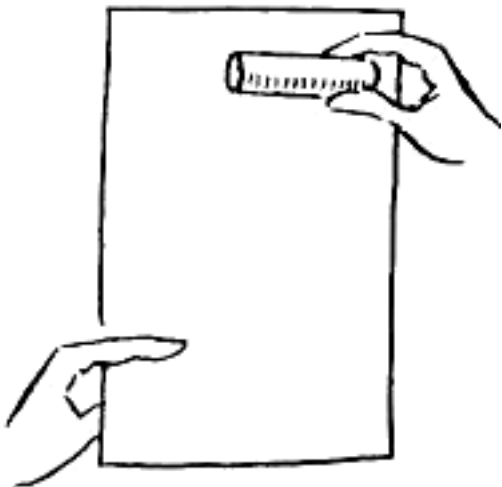


FIG. 82

Slide left hand to lower edge of paper with forefinger in back and thumb and other fingers in front. Right hand holds paper at upper edge, and thus you show one side of paper.

Figure 82.

Raise lower part of paper upward between tube and upper edge. To do this, turn paper upward toward yourself and roll it up behind tube.

Figures 83 and 84.

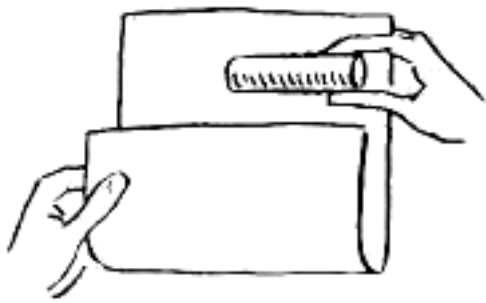


FIG. 83

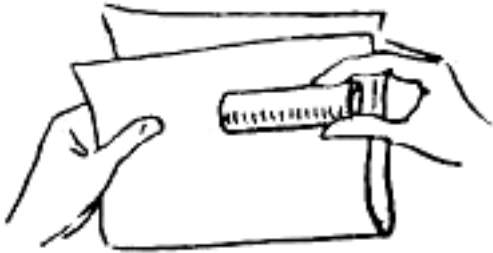


FIG 84

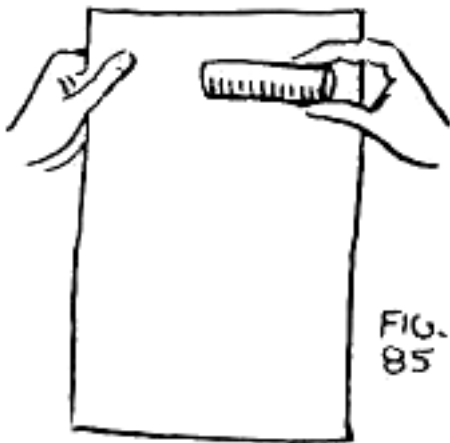


FIG.
85

Now drop upper edge of paper from right hand. Grasp lower edge, which is now at top, as before, with tube behind paper held by thumb and forefinger and other fingers in front.

Figure 85.

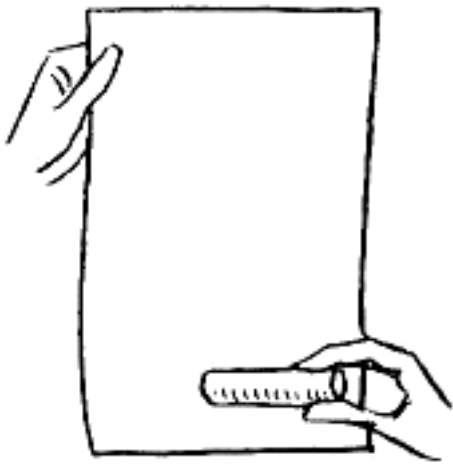


FIG. 86

Bring tube to bottom of paper in preparation for wrapping it in paper.

Figure 86.

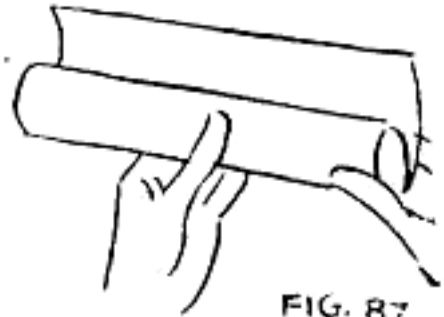


FIG. 87

With aid of left hand wrap tube in paper. To the audience it appears that you merely make a tube of the empty paper.

Figure 87.

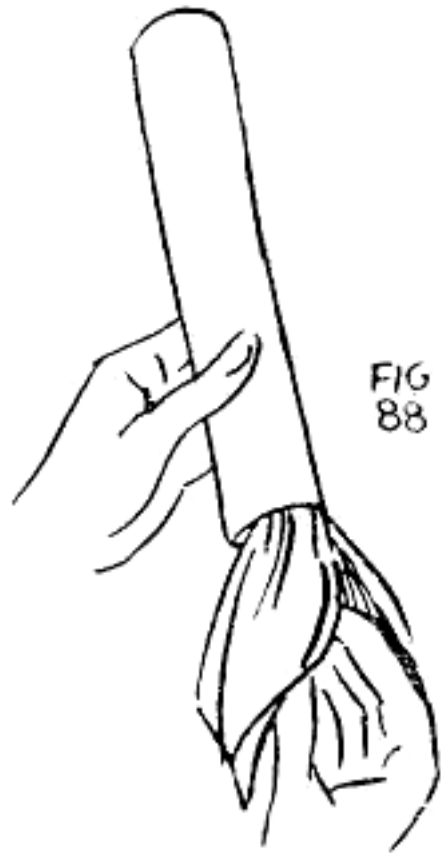


FIG
88

Pick up one white silk from table with right hand as you hold paper tube in left. Push the white silk into cup end of metal tube and slide cup up a little way. Of course, the audience sees you do this.

Figure 88.



FIG
89

"The first stage is the cleaning stage. A dress is pushed into one end of the tube and is taken out of the other end."

Tap tube against right hand a little so that white silk at loaded end of tube will come out far enough for you to grasp it. Remove white silk with right hand and place on table.

Figure 89.

"A very simple process but important. Not only does the tube clean the dress, but the dress also cleans the tube."

Holding tube in left hand, push the second white silk into cup end of tube, thus pushing the pink silk at other end upward.

"Now, the dyeing process is similar to the cleaning process, except that the tube is held at a slightly different angle and the silk remains in the tube a

little longer. The length of time varies with the particular color.

Tap tube against right hand again so that pink silk comes out at top and can be withdrawn with right hand. Show the silk freely.

"I didn't keep it in the tube long enough so that the dyeing is rather faint. Let us try again and keep it in a moment longer."

(39-20)

Push pink silk into bottom of tube, tap tube, and remove red silk from top.

"There, that's better. Milady now has a nice red dress. Or as I overhear someone remark—he read it in the paper."

Place red silk in center of table and pick up another

white silk.

"This, likewise, goes into the paper."

Push white silk into bottom of tube and pick up last white silk.

"While we are dyeing for a living, we will add this one."

Push silks up with sliding cup so that both green and blue silks come out at top of tube but are still concealed by paper. Be sure paper tube is straight so dye tube can easily slide out at proper time. Tap tube against left hand and draw out green silk.

"For the benefit of my Irish friends, how is this?"



FIG
90

Remove green silk with left hand and place it toward rear of table. As you do so, let right hand with tube come to rear edge of paper just over the Servante. Allow dye tube to slip out of paper tube and down into Servante.

Figure 90.

Do this very quickly and raise paper tube immediately. Tap tube against left hand again and remove blue silk.

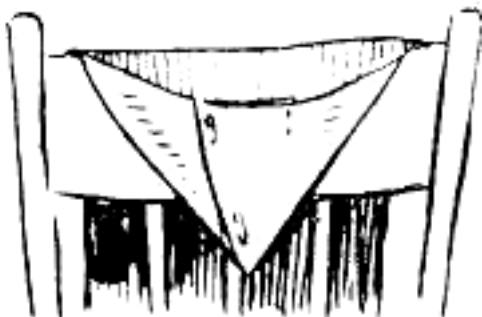
"This was left in the tube longer and that's why it assumes a darker color unless the wind blew (blue) it."

Place blue silk on table with the red and green ones. Unroll paper tube and show it empty on both sides.

"And so, dear ladies, you have an easy process of dyeing."

VARIATIONS:

The Chair Method--



REAR

FIG. 91

A Chair Servante is easy to make. Have a fancy drape over front of chair and pin up the back to form a bag in which to dispose of the dye tube. Place two thumb-tacks through cloth at top of chair to hold it in place.

Figure 91.



As you remove colored silks from tube, lay them over back of chair. When time comes to dispose of dye tube, hold hand back of the chair and over Servante and drop tube quickly.

Figure 92.

(39-21)

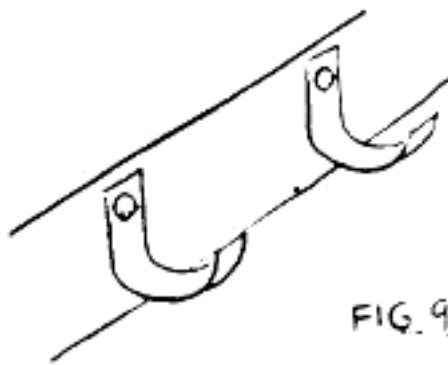


FIG. 93

If you use this type of Servante, a handy holder for the loaded tube before you use it is made of two curved pieces of metal, tacked to back of table or chair.

Figure 93.

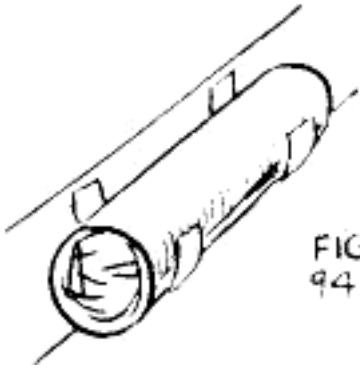


FIG
94

Figure 94 shows loaded tube resting on holder.



FIG. 95

Chinese Girl Assistant Method--

If using an assistant, you may have her dressed in Chinese costume with wide sleeves. Make a small Servante and pin it to her right sleeve. Have her enter from right and keep her right side toward audience so that she can keep Servante concealed.

Figure 95.



FIG 96

As you remove silks from tube, place them over assistant's outstretched right arm. At proper time, dispose of tube in Servante in assistant's sleeve. Have her arrange silks over Servante and exit with them.

Figure 96.

An Easy Get-Away--

A simple ruse to use when you have an assistant is this: Have assistant bring her left hand up to bottom of paper tube when you are ready to dispose of dye tube and catch dye tube in palm of hand. Then assistant removes silks from right arm with left hand, concealing tube. This eliminates the use of a Servante.

The Pocket Method--

I have used this method on occasions when I had no chance to prepare a chair or table and had no assistant.

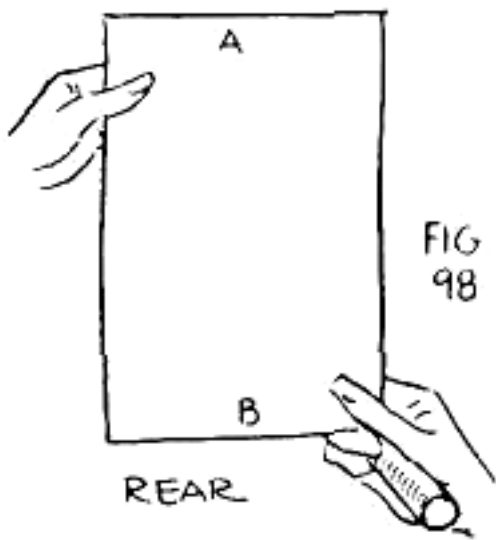
Tube is loaded and in right coat pocket. On top of it are the three white silks. Remove the silks and place them over your left forearm. Hold sheet of paper in left hand and turn left side to audience to show silks.



Reach into right pocket with right hand and Finger Palm the dye tube. Keep back of hand to audience and turn to face audience again.

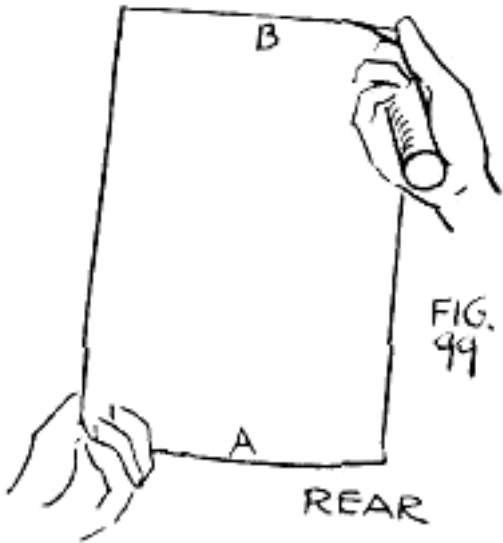
Figure 97.

(39-22)



Grasp paper between hands as in Figure 98, keeping tube concealed in right hand.

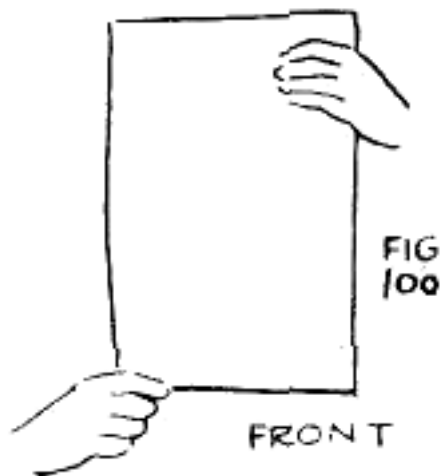
FIG 98



Bring left hand outward and down with upper edge of paper to show other side. You have now shown both sides of paper without exposing tube.

Figure 99.

FIG. 99



Bring hands back to former position again.

Figure 100.

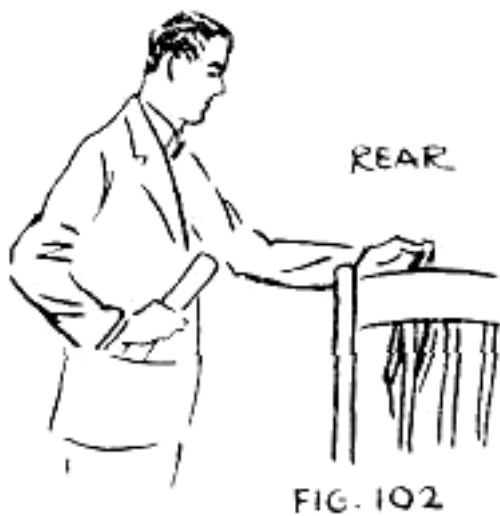
FIG 100



Bring right hand up behind paper with tube and grasp it at top edge of paper in left hand. Roll tube up in the paper, giving impression that you are merely rolling up paper.

Figure 101.

FIG 101



Proceed with dyeing experiment. If a chair is handy, lay silks over top of it. As you place second colored silk over chair, turn left side to audience, bring right hand to coat pocket, and drop dye tube in pocket.

Figure 102.



Another Get-Away with tube is this:

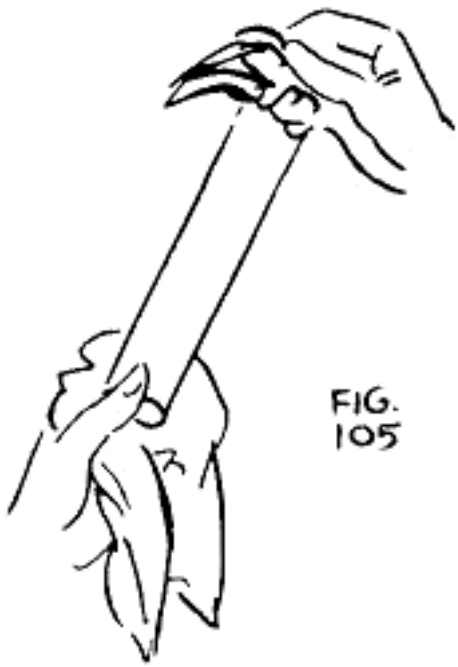
When red silk is removed from tube, hold it in left hand.

Figure 103.



Tap tube against left hand to bring green silk out a little.

Figure 104.



Bring bottom of tube over to left hand and remove green silk with right hand.

Figure 105.

FIG.
105



Hold green silk between third and fourth fingers of right hand and take paper tube from left hand, allowing dye tube to slip into left palm.

Figure 106.

FIG.
106



Place green silk from right hand over dye tube in left.

Figure 107.

FIG.
107



Place both silks with tube in left coat pocket, allowing silks to show.

Finish experiment by removing blue silk from paper tube and showing paper tube empty.

Figure 108.

FIG
108

FURTHER SUGGESTIONS:

The dyeing principle can be elaborated on to make it a big effect. The tube can be made large and big silks used. After the three silks are produced, they can be pushed into tube again and a large, beautifully designed silk or a flag produced.

The effect may be performed in pantomime in an Oriental act.

Ade Duval, who has specialized with silk acts, gets a

beautiful dye tube effect with rainbow silks, finishing with the production of a large, variegated silk.

Another interesting variation of this experiment is one in which you show three squares of tissue paper, tear them up and push them into tube, and then pull out silks from other end. This shows process of making silk from paper.

(39-24)

THE BIRTH OF OLD GLORY

A pretty silk effect with a flashy ending. This can be adapted for use with the flag of any country.

EFFECT:

Performer shows three silks separately—red, white, and blue. He knots them together and suddenly changes them into a large silk American flag.

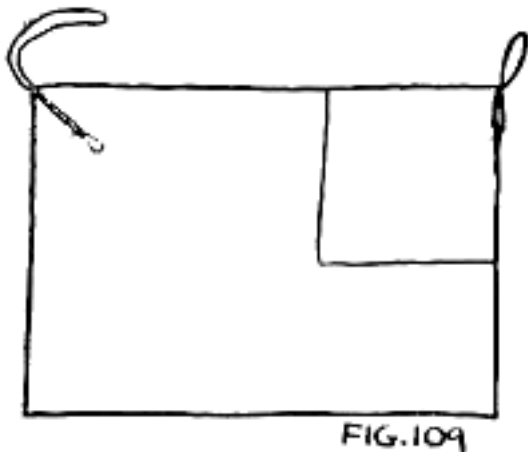
PARAPHERNALIA:

1--Three silk handkerchiefs, 15 inches square. One red, one white, one blue.

2--Two silk American flags, about 24 x 36 inches.

3--Minor accessories.

SECRET:



To Prepare:

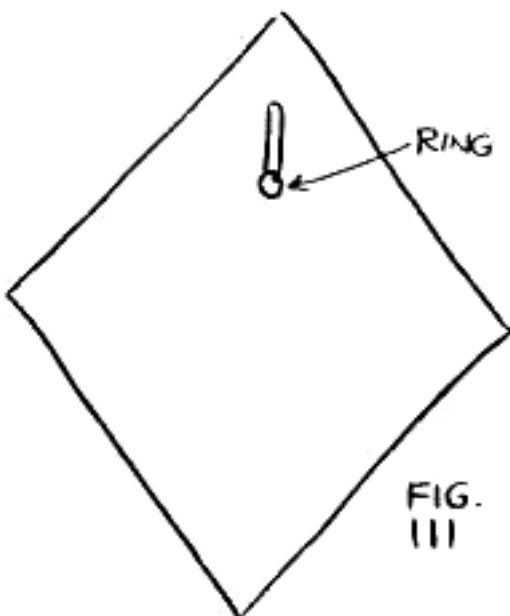
Place the two flags evenly together and sew them all around the edges except for a space about three inches long at upper right edge. Sew a loop of fishing cord or catgut at each of upper corners. Turn flags inside out and to upper left corner sew a piece of blue ribbon.

Figure 109.



To the blue ribbon attach a fastener like the one shown in Figure 110.

Turn flags back to right side. Around opening at upper right corner, sew a piece of soft wire or two pieces of whale bone or cardboard to stiffen opening and facilitate the rapid pulling out of silk handkerchiefs.



The blue silk is also prepared. This should be very dark and as opaque as possible. It may be necessary for you to sew two blue silks together to make it opaque. Sew one end of a strong piece of blue ribbon, about 3 inches long, to the silk. To free end of ribbon, sew a small metal ring.

Figure 111.



Take the double flag. Reach through opening, grasp the fastener inside and pull it out.

Figure 112.



Keeping fastener outside, tuck left side of flag in evenly.

Figure 113.

FIG
113

(39-25)



FIG.114

Starting with lower edge, roll up flag and put a strip of tissue paper around it to hold it. Glue ends of paper to form a ring. This keeps flag from unrolling and yet breaks easily if flag is jerked.

Figure 114.

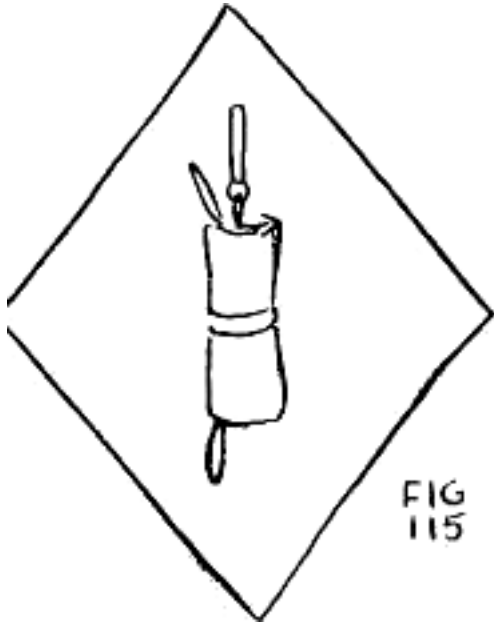


FIG 115

Hang flag on back of blue silk, snapping the fastener of flag through the ring.

Figure 115.



FIG 116

Drape blue silk around flag bundle to conceal it, and place on table with the white and red silks.

Figure 116.



FIG 117

To Perform:

Pick up blue silk by upper corner and hold in left hand. Pick up white silk and place it beside blue one in left hand.

Figure 117.



FIG
118

Now pick up red silk and place with other two in left hand. Tie all three upper corners into a knot to hold the silks together.

Figure 118.

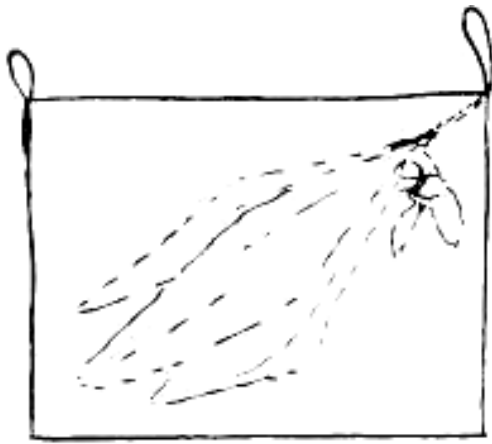


FIG
119

With thumbs reach down behind blue silk, open it, and get left thumb through lower loop on flag and right thumb through upper loop.

Figure 119.

(39-26)



Pull hands apart. The tissue paper around flag breaks and the flag unfolds. At the same time, the three handkerchiefs are drawn inside of the double flag through the opening.

Figure 120.

FIG. 120



Figure 121 is a view showing performer and flag as audience sees them.

Harlan Tarbell

TARBELL SYSTEM, INCORPORATED, Chicago.

* * * * *

LESSON 40

FIG. 121

In your next lesson, I shall give you Dr. Milton Bridges' method of changing three unprepared silks into an unprepared flag, and more good handkerchief effects.

The lesson also includes discussion on reading character and handling different types of people.

LESSON 40

CHARACTER ANALYSIS

AS RELATED TO MAGIC

Much of your success as a Magician depends on your understanding of people. You must sell yourself and your wares, and you cannot do it successfully unless you know people. There are magicians who have beautiful shows and do not know how to sell themselves.

Before you can present your performance, you must first sell it. You may have to see a number of individuals to get an engagement – it may be a booking agent, a manager, a high school superintendent, a minister, or a doctor. You must gain the confidence of the people you see and make them feel that you are a master, a new attraction, better than anyone else they have seen.

The important thing for you to do is create the right impression and get people to like you. Too many sales have been spoiled, not because of the goods, but because the buyer took a personal dislike to the salesman. The great basis, then, of successful salesmanship is in understanding the likes and dislikes of those with whom you are dealing. When you understand these things, you can paint just the kind of a picture for the buyer which will give such strong promise of satisfying his wants that your sale is assured.

Everyone has something to sell. Every man is a salesman, in some sense of the word, whether he is marketing commodities, skilled service, or ideas; whether he is selling his personality to his sweetheart, his family, his friends, or his business associates. And just as everyone is interested in selling something, so everyone is equally interested in buying what he needs. And when a man is buying, he is attracted most strongly to those things which he likes and which he believes will meet his needs.

Likes and dislikes can be accounted for, definitely and scientifically. They are part of each individual character and are written on every human face, where they may be read, not by guesswork, but with scientific accuracy. The unsuccessful salesman does not know these things and he fails.

I want YOUR success to be assured, and so I am going to give you an insight into Character Analysis. I am going to give you a quick and dependable working knowledge of people so that you will know what picture to paint, what button to push, and what package to offer in order to attract favorable attention with different people, arouse interest, awaken desire, inspire confidence, and effect the sale of yourself and your Magic.

THE THREE TEMPERAMENTS

There are, generally speaking, three big classifications of people. Each class is as different as night and day in its likes and dislikes. People in each class may differ somewhat from each other, but in their basic desires, they are similar. Back of these three divisions of people is a scientific reason, the result of heredity and environment.

There are three things necessary for the construction of man, without which he could not exist. They are Vitality, Will, and Mentality. They are sometimes called the Triangle of Life. Each has a definite purpose and each plays its own part in man's life, and the loss of any one would cause disease, death, and dissolution.

We speak of Vitality, Will, and Mentality as the Three Temperaments. A knowledge of these Temperaments, their location and development, their relative proportion to each other form the basis of Character Analysis. These show the foundation on which man's tendencies are built.

Each individual possesses all three of the Temperaments, but there is a difference in proportion and relative development of each one. For rapid analysis, the predominating Temperament is determined -- that is, the one which has the greatest development -- and is used as a basis.

Now, I shall discuss the three Temperaments so that you will understand them individually:

A - THE VITAL TEMPERAMENT -

This Temperament controls the vital organs, the blood supply, and nutrition. The vital processes of life depend on it -- warmth of the body, digestion, assimilation, absorption, and secretion. It gives man hunger and makes him distinguish the requirements of his body through his senses of feeling, smelling, tasting, seeing, and hearing. It is essential to reproduction and growth. Herein lies the great chemical laboratory of the body. It also gives the power of relaxation and sleep, creating in man the desire to seek comfort and to accumulate plenty of material things. Vitality is magnetic. It makes man sociable, agreeable, and lovable. In combination with the other Temperaments, it fires them to action.

The Vital Temperament builds a circular or rounded face. Quantity of development is typical of this Temperament.

B - THE WILL TEMPERAMENT -

This Temperament controls the muscles, ligaments, bones, and glands. Upon this Temperament depend the power of contraction and tension and the density of the body structure -- the hardness and compactness of the muscles, ligaments, and bones. It holds the minute structures together and blends them into one, giving the body power to stand erect, power of mobility, equilibrium, and resistance. It has the power of locomotion, protection, and defense. It has a cooling power and acts as a balance to the warmth of the Vital Tem-

perament. It gives repelling power and makes a man reserved, conservative, skeptical, and cautious.

The Will Temperament, because of its tension and concentration powers, builds structures that are muscular, ligamentous, or bony. It builds an angular, square face. The sides of the jaws form a perpendicular line running down from the head. Solidity of development is typical here.

C - THE MENTAL TEMPERAMENT -

This Temperament controls the nervous system and brain. It is the result of experience of mind and body, and it is the basis of the power of comprehension. It arranges, harmonizes, and refines the influences of structure and chemistry of the body. It enables every cell in the body to work in an intelligent manner, peculiar to itself. It enables the brain to grow brain cells - the liver, kidneys, stomach, and heart cells to carry on their respective work and duties. Wisdom, knowledge, consciousness, recognition, and interpretation are dependent on this Temperament.

The Mental Temperament builds a face triangular in shape, due to lessened development in the Vital and Will Areas (which you will soon learn). The nose and upper lip are refined and highly organized. Quality of development is typical of this Temperament.

* * * * *

From a study of the three Temperaments, we can readily see a great difference in people. Some have great Vitality --blood-making and relaxing power -- but have poor resistance and are not keen in creative mentality. Others have powerful strength, love to work hard, have solid bones and muscles -- but have poor assimilative powers, are overtensed, and have but moderate mentality. Others may be mentally bright, quick to think for themselves and invent improvements -- but have poor vitality and resistance to support their mentality.

No Temperament is strong in itself -- it must be supported by the other two. What good is a keen mind without blood to feed it and muscle and bone power to support it? What good is force without intelligence and creative energy behind it? And what good is the finest building material without something to build it into and without intelligence to direct the building? A perfect development of all three temperaments makes a BALANCED person, and that's what progressive people of today are striving to make of themselves.

The average person, however, is unbalanced temperamentally. That gives rise to the somewhat intolerant likes and dislikes which we find in people. Each sees through his own individuality. The Vital Temperament sees through the eyes of vitality; the Will Temperament sees through will; and the Mental Temperament sees through mentality.

Therefore, when you sell to Vitality, Will, or Mentality, you must talk the language which each will understand. When you have finished this discussion, you will have an understanding of the way in which to appeal to each class.

(40-3)

CHARACTER UNFOLDMENT

In studying character, it is important to bear in mind the great difference between the mental powers of infancy, childhood, early adulthood, and maturity. Ripened character grows from the experience of years and does not come over night. An understanding of the manner in which character unfolds will teach you how to deal with people of different ages and of different stages of development.

First there is the baby. When he is born into the world, he has a blank mind. Every impression made on that mind will be the result of personal experience of the infant. His character will depend on his environment, just as the impressions on a phonograph record depend on the sound waves to which it is subjected.

Heredity and Environment Unfold Character

True, of course, that the infant inherits potentialities in his brain -- faculties which come from his ancestors -- but all he will really know of the world about him will be gained through personal experience. His inherited potentialities will flourish and ripen or wither and die, according to his environment. Heredity governs a human's reaction to his environment, but environment molds the development of the inherited tendencies.

So we see that heredity and environment both play their parts in the unfoldment of character. Each influences the other, and neither is all-powerful. The relative development arising from the relationship of environment and heredity is an important thing to study in analyzing character.

No two characters develop in just the same way or at just the same speed. Age in years may mean much or it may mean little. A man of forty may have less maturity of character than another at twenty. Some people never grow up mentally. They remain throughout life dependent on the thoughts, guidance, and protection of others. Other people are surprisingly mature at adolescence.

Necessity Develops Character

Necessity is what brings out the best in man. The need for solving the mysteries and overcoming the obstacles of life tends to make a rich, well developed mentality. Responsibility evokes our highest qualities. It is, therefore, every man's duty to himself to assume responsibility and thereby make himself a master.

The child who is indulged in everything and is surrounded with every comfort, who is pampered and catered to instead of being required to earn what he gets, is cruelly handicapped by his well-meaning parents. He comes to rely entirely on fortunate circumstances and not on himself. Life looks so easy to him but he has power only as others will respond to him. Caught in an emergency where he can save himself only by independent thought and action, he is lost.

Stages of Unfoldment

1 - In infancy and early childhood, we were interested chiefly in getting enough to eat and drink, in having plenty of sleep, and in amusement and play. We let our parents assume the responsibility of protection. Our future life was a fairyland of glittering possibilities. Our imagination had free reign, and nothing seemed impossible.

2 - Then, for most of us, came a time when stubborn facts stared us in the face. We ran against stone walls wherein there were no hidden doors that yielded to magic words. We found that the walls of real life had to be surmounted or battered down if we were to get past the barriers. Then if we were weak, we yelled for help or else sat down and wept. But if we were wise, we began to prepare ourselves for the fight.

When man realizes that outside aid is not always dependable and that he must rely primarily on his own resources if he is going to succeed, he begins to profit by experience. He begins to defend himself and to act according to his knowledge of realities. He has been misled by second-hand information. Now he wants facts. He looks for a solid foundation on which to place his foot.

Caution becomes one of his great defenses. He used to believe in everything and everybody, but his so-called authorities have led him astray so often that now he is a Doubting Thomas. He looks on the dark side of things and believes that nothing is good until its virtue is abundantly proved in a tangible way. He demands material proof.

In his impressionable days, he judged by appearances and he followed the crowd. But now he has learned to look beneath the surface. Having been disillusioned, he becomes indifferent to the opinions of others and realizes that for his own protection his greatest need is power.

3 - The next stage for us comes now. After having withdrawn into a shell for a time, it dawns upon us that we have not solved the great mystery of life. We are avoiding the bad but also missing the good. So we start reasoning -- seeking the whys and wherefores. We go out in search for the truth, and then we realize that nothing is wholly good or wholly bad. We begin to sift the wheat from the chaff so that we may use that which is worth while and discard that which is not.

Here we have the evolutionist. He has become the creator, the planner, the inventor, the reconstructionist, who abandons the old as soon as he can devise something better to take its place. He finds that his ideals are growing steadily higher, but no matter how fast he climbs, his ideals are still beyond his reach. He is striving for perfection. He realizes that there is something higher than physical comfort or the power of force -- it is wisdom.

Every past experience has been a stepping stone to truth. And the more he learns, the more he realizes the infinity of what is still to be learned. As he grows in wisdom, he grows in humility. The narrower a man's circle of vision is,

the greater he thinks himself. As the circle widens, his perspective changes. This man's vision has become so broad that he sees himself as only a tiny atom in God's great cosmic plan. He is getting close to the answer of life's riddle. He is on the threshold of true greatness.

4 - He has worshiped in turn at the altars of love, force, and wisdom as he climbed the mountain of life. Now he is near the crest and he turns and looks down on the valley below. Most of his companions are still judging by appearances and following the crowd in their first stage of development. Some are hidden and afraid to come out and some are ruling by force in their second stage of development. And a few are still striving for knowledge in their third stage of development.

Now he is the master - at the highest stage of development. Suddenly he hears a wild cry for help from the multitudes in the valley below. They are caught in a crisis which they cannot understand and from which they see no escape. They need a leader, and there is none amongst them who can lead. From his high point of vantage, he sees in a flash what must be done and he jumps into the emergency, leading the multitude with the combined love, force, and wisdom of a master.

The great men of history did not just "happen." Every one of them had lived, learned, and suffered. Every one of them went through, in one way or another, the stages just described until he reached the summit and was prepared for the great emergency.

These four statements sum up the stages of Character Unfoldment:

First he didn't know, and he didn't know that he didn't know.

Then he didn't know, but he knew that he didn't know.

Later he knew, but he didn't know that he knew.

At last, he knew, and he knew that he knew.

* * * * *

THE FOUR SENTIMENTS

Character Unfoldment has thus given rise to the Four Sentiments. These Sentiments were defined by Harry Daniels, eminent ontologist, a number of years ago. They have opened up a powerful aid in reasoning out and analyzing life's problems. Each Sentiment is the motivating power of each of the stages of Character Unfoldment and is allied with the Three Temperaments.

A - THE COMMERCIAL SENTIMENT - (Vital)

This is based on the law of self-preservation. The first interests of the new-born babe are eating, sleeping, and

enjoying physical comfort. The baby is helpless -- it is dependent on someone else to care for it. It trusts in other people, and its rebellion comes only when things displease its physical senses. It judges by impressions. It is emotional.

Study the baby -- his little upturned nose and fat cheeks -- and you have the characteristics of the man motivated by the Commercial Sentiment.

In the world at large, this Sentiment acts as the basis for enterprises which supply the body with material needs. Commercialism has thus arisen and fosters the occupations of life dealing with physical pleasures of the people.

It is the Sentiment of Chemistry, which deals with the attraction and repulsion of chemical elements in the processes of life. It is magnetic and attracts those things which supply material comfort.

It is the Sentiment of Authority Worship. A man in whom this Sentiment predominates depends on the doctor for health advice, the minister for religious help, and so on.

B - THE PROTECTIVE OR ECONOMIC SENTIMENT - (Will)

This Sentiment is developed through man's necessity for protection. As a Commercialist he trusted to others and found that they did not come up to his expectations in emergencies. He bumped into obstacles. He discovered that many of his teachers were wrong. He found opposing forces on every hand and a power in nature that was willing to destroy him if he would let it. So he had to build defenses to protect himself. Instead of remaining an AUTHORITY WORSHIPER, he becomes a DOUBTING THOMAS. Now everything has to be proved to him before he will believe it. Instead of being guided by his emotions, he depends on cold hard facts.

Now for his protection he has developed memory, observation, concentration, language and expression, home and family protection, methods of aggression and defense, caution, secrecy, ownership, and monetary standards.

For his characteristics, he develops hardened muscles and bones, his face squares and his turned-up concave nose becomes a convex one with a high bridge. He burns up vitality in active defense and his cheeks lose their fulness.

An the Commercial Sentiment is magnetic, the Protective Sentiment is repellent. As the former is warm, the latter is cold. They are opposites in characteristics. The Protective Sentiment makes laws and wants those laws enforced. It forces its opinions on others. It studies the structures of things -- it gives resistance and the power to withstand the opposing environment. It demands material proof.

C - THE EVOLUTION SENTIMENT - (Mental)

This Sentiment makes the self-investigator or student in man. With the commercialist believing in authorities and the Protectionist being a Doubting Thomas, man in this third

development goes a step higher and says he will find the truth through investigation. He seeks to understand and improve.

The Commercialist moves in a small circle because he is satisfied. He believes in letting well enough alone. If his physical wants are satisfied and he already has more than he needs, he sees no reason to leave it. So he settles down and becomes overweight. The Protectionist gets out of the small circle because of necessity. He found opposing forces and he goes out of the small circle to build his defenses. The Evolutionist is not satisfied with what he found in either of the two circles so he starts out in new territory. He pioneers. He moves in larger circles and goes out for knowledge where either of the other two types would fear or not be interested in going.

This Sentiment is interested in the intellectual side of life and in those things which impart wisdom. It seeks understanding and better ways of doing things, paying attention to causes and effects, to result and consequences, in order to shape the environment of man so he can meet the greatest happiness of mind and body. This Sentiment is inspirational, imaginative, creative, reasoning, devotional and expansive in thought, craving for harmony, liberty and justice.

D - THE INDIVIDUAL SENTIMENT - (Combination)

This is the highest stage of development. After a man has gone through the other three Sentiments and knows from experience the TRUTH about things and the way in which to handle them to the best advantage, he becomes a MASTER and can stand on his own individuality.

This Sentiment comes as a result of the intermingling of the other three Sentiments. It is the result of construction, force, and intelligence. It embraces the god of love, of power and of wisdom. In it are born culture, progress, worship, humanitarianism, love, unselfishness, rulership, and the highest faculties of man. It expresses maturity. Its unselfishness is important. It realizes the power of cooperation and of helping others. It has learned that only by helping one another can the members of the human race survive.

The Commercial Sentiment, being based on self-preservation, is naturally selfish. It thinks of self first -- it would rather receive than give. The Individual Sentiment gets its greatest pleasure in giving -- its happiness is in making others happy. The greatest masters of the ages were strongly developed in this Sentiment.

* * * * *

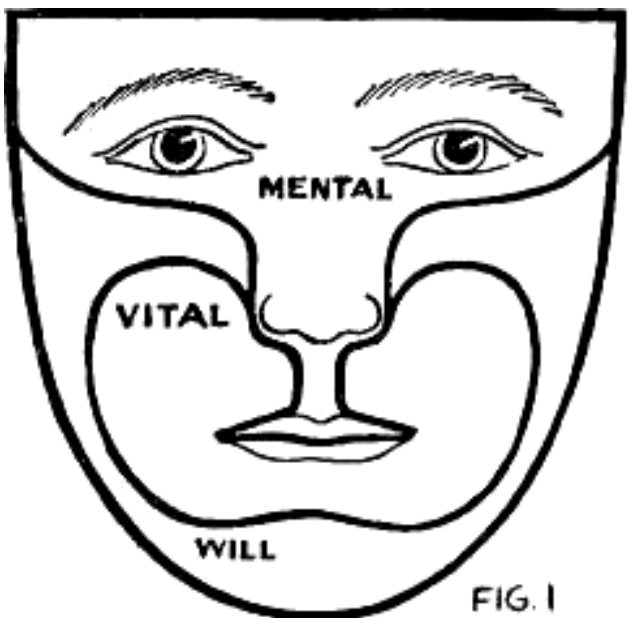
HOW TO LOCATE THE TEMPERAMENTAL AND SENTIMENTAL DEVELOPMENT OF THE FACE

For rapid analysis it is well to read the Temperamental and Sentimental aspects of the face together as they are closely related.

The face can be divided into three great areas. The Vital-Commercial is located in the cheeks, in the fleshy, non-bony

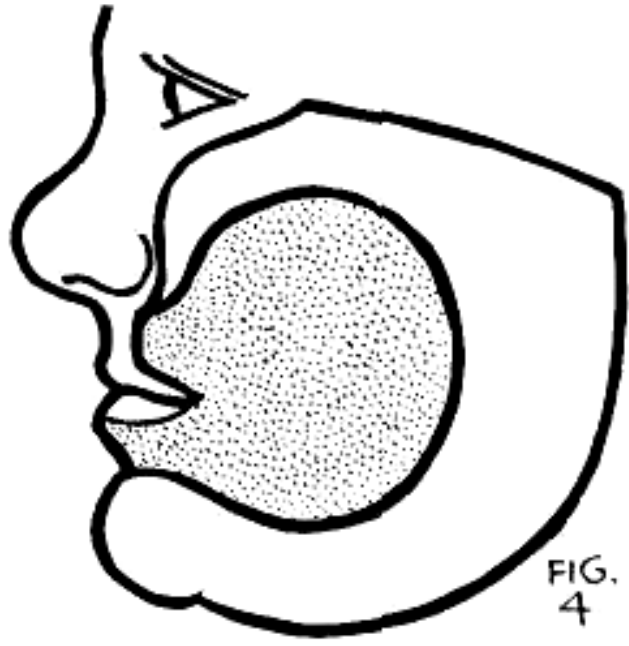
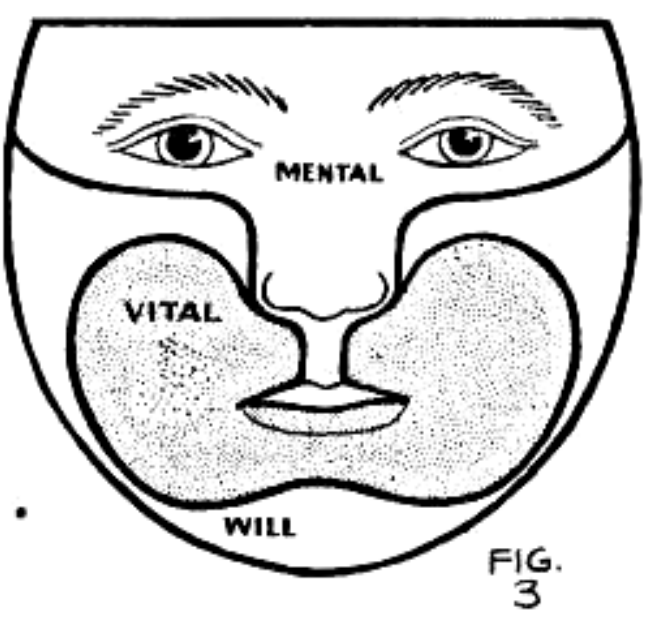
region. To determine this region, look in the mirror and puff your cheeks out with air. The Will-Protective area is formed by the cheek and jaw bones. The Mental-Evolution area consists of the upper lip, the nose, and rest of the head.

Figures 1 and 2.



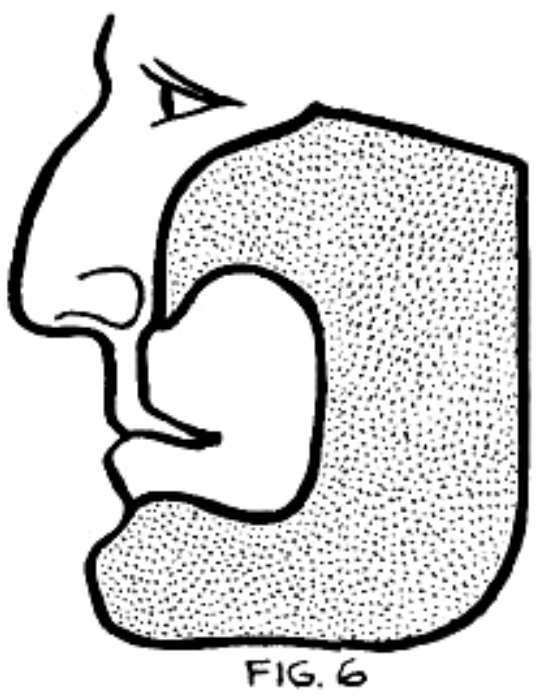
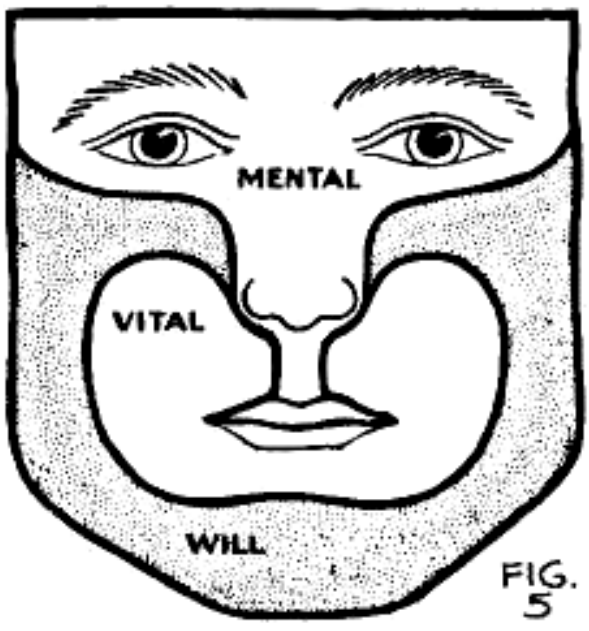
When the Vital-Commercial predominates, the cheeks are full and the face rounded.

Figures 3 and 4.



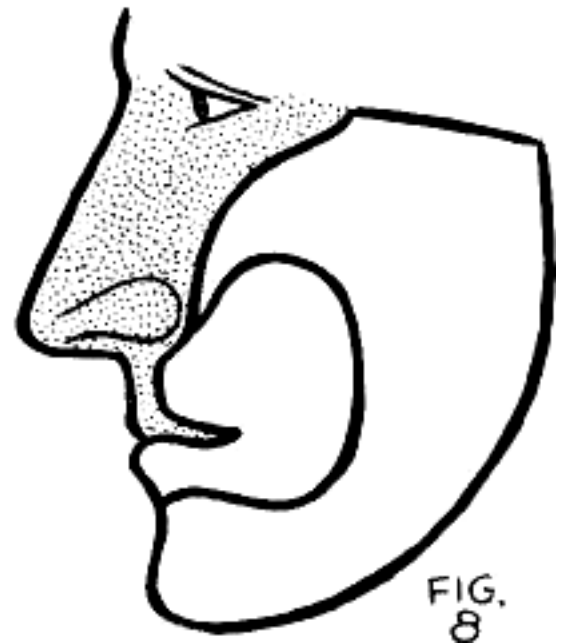
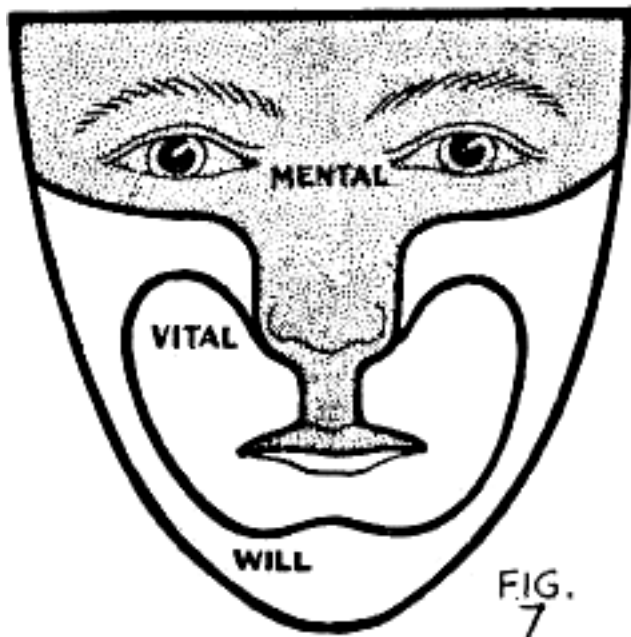
When the Will-Protective leads, the jaws are squared. The lines from ears to jaw are straight up and down.

Figures 5 and 6.



When the Mental-Evolution predominates, the face is triangular in shape. The cheeks and jaws are not well developed. The nose is finely developed – it is rather narrow and finely chiseled.

(40-9)



Many people are so unbalanced that the predominating Temperament and Sentiment are easily recognized. Determine this first and then appeal to the man according to his stage of life. If the various areas blend harmoniously, appeal to all of them.

We will not discuss the areas manifested by the individual Sentiment as it results from the powerful development of the three areas just discussed. Your problems are not with the individual Sentiment as it seeks to help you. But you do need to know the three I have described.

* * *

Your power to control people and appeal to them will depend a great deal on your ADAPTABILITY.

Some people refuse to adapt themselves to others, but expect others to adapt themselves to their requirements. This is a mistake if you wish to be a successful salesman. You must first meet a man on his own ground, get his confidence, and then take him over to your side. You must be tolerant and understanding. Remember that your appeal is for a purpose, and though you may have to bow down for a while, in the end you win.

The world craves appreciation and understanding, and if you can show a man that you are appreciative of his wants, you have won a big part of the battle. There are times when we must yield as well as times when we must stand pat.

Discover the kind of heaven which a man has in mind, and you stand a chance of winning that man. The Commercialist will talk about leaving this vale of tears and going to a land where all is comfort and peace and eternal happiness -- where angels play beautiful music on harps. There he will have no more work, no more suffering, and everything his heart desires will be his. He pictures heaven as a place where all his physical wants will be taken care of and where there will be no pain. He hates pain. He is the type who makes a big fuss over some small ailment and goes to a dozen doctors.

The Protectionist's idea of heaven makes it a place where people obey the law and behave themselves and where he doesn't have to be on his guard most of the time against people who would take advantage of him. He wants a heaven where he can work in peace and accomplish something. The Commercialist doesn't want work in heaven but the Protectionist does. He hates lazy people.

The Evolutionist's idea of heaven is a place where there are stages of development and where finally one is educated to complete understanding. He believes that in his heaven wisdom solves all life's problems.

Thus you can readily see why some people worship the god of love, the god of power, and the god of wisdom.

The Individualist realizes that happiness comes from a consolidation of all three gods – from the proper development and balance and use of all three.

Let us now take up the big, important elements in your appeal to the three common types. We shall not discuss the Individualist for he is in the great minority and, besides, he naturally seeks to help you.

The Commercialist

Appeal to him through feelings, emotions, appetites, and impressions, for he is guided by these rather than reason. He judges success by financial power and material results. He judges you by your appearance, your dignity, your reputation, and your prosperous appearance. He is a slave to custom and goes by appearances and hearsay. He bows his head to authorities and celebrities. He caters to public opinion and wants to stand as a shining example to others. He wants thorough appreciation and sympathy. He accepts praise at its face value. He welcomes any proposition that will enhance his position and reputation. He likes to deal with a big firm that has many branch offices and has been in business for many years. "Established 1812" commands his respect.

Figures 9 and 10.



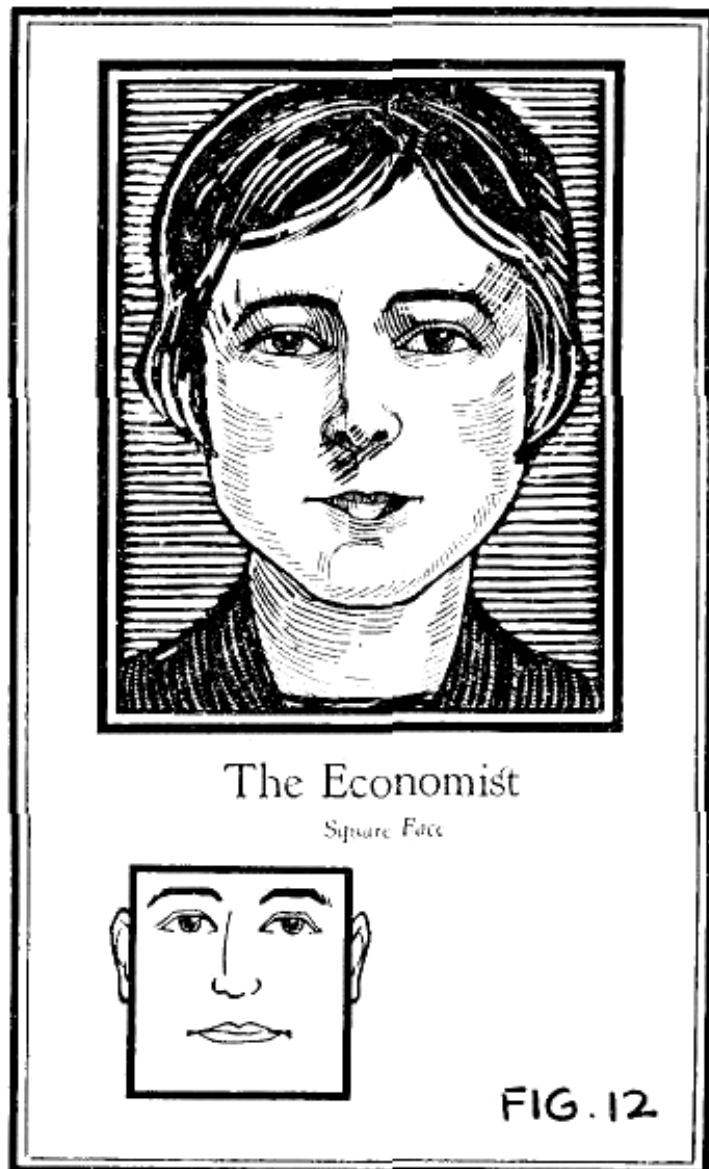
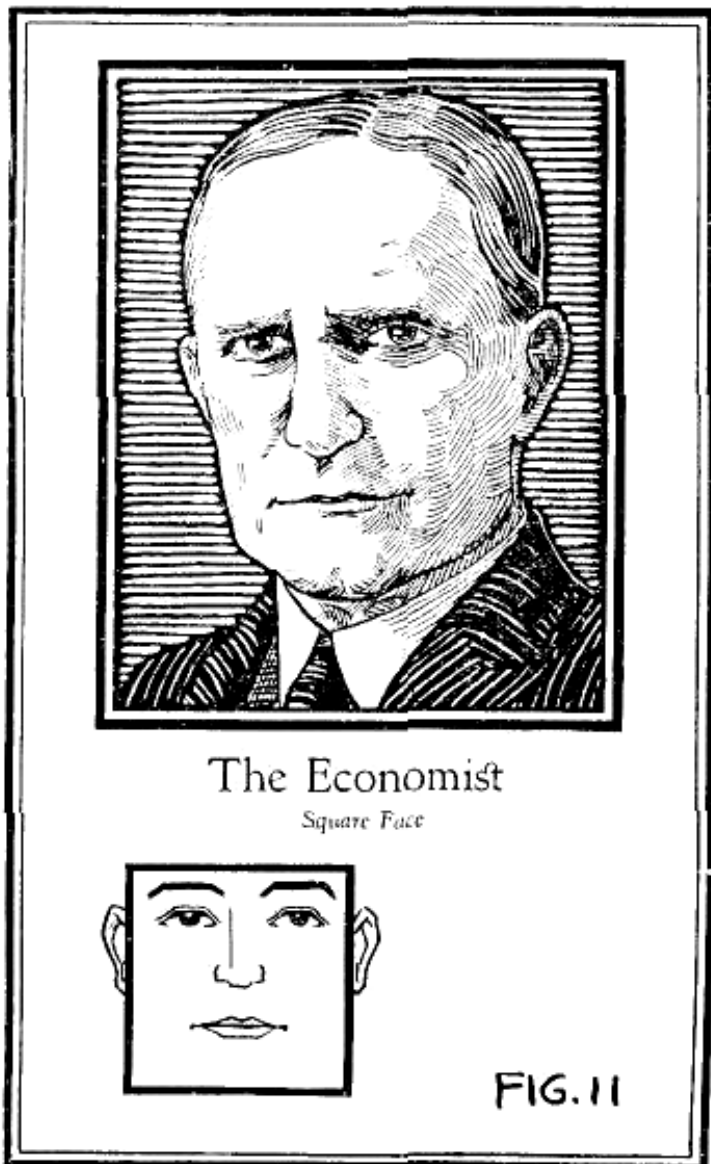
This man enjoys ceremony and display. Mystery fires his imagination. He is extremely sensitive to criticism and it is hard for him to admit his faults. In suggesting any changes or improvements in his business or other affairs, great tact must be exercised to avoid inferring that he is inefficient. He dislikes people who try to reform him, change his mode of life, or interfere with his personal liberty.

He loves comfort, funny stories, sociability, and enjoys the material "good things of life" -- eating and entertainment. In business he judges by appearance, quantity, size, weight, price, and testimonials. He is interested in big profits, inside offers, special discounts, premiums, and "exclusive models." He likes to take his time, so do not hurry him. His leisurely congeniality, however, does not always mean business. When he does give his order, it is wise to get it in writing, for he is subject to change of mind or to forgetting the details of a contract.

The Economist or Protectionist

This man responds to an appeal that is practically the opposite of the one described above. The Economist is guided by reason rather than by impression. He wants demonstration, not talk. He is on the defensive, seeking always to protect himself. He is a "brass-tacks" customer - he wants facts. His time is money. He judges you by your efficiency, not your appearance. He expects you to get to the point quickly and then get out. He dislikes "fancy" salesmanship. If he wants to buy, he buys. If he does not want to buy, he cannot be sold. He seeks not praise, but power. He does not go out of his way to make people like him.

Figures 11 and 12.



He seeks efficiency and the things that will enable him to increase production. He wants time-savers and things that have resistance and durability. Talk to him concisely and definitely. Do not exaggerate for he is looking for flaws and will usually find them. He is suspicious of praise and resents undue familiarity. He wants value. Experience has taught him to beware of something-for-nothing propositions. He must be shown. He dislikes sham and empty display. He suspects ornateness of hiding something wrong. He will recognize real superiority of an article when it makes for safety, efficiency, practicability, and durability -- in other words, when it has real value. He cares nothing for testimonials -- he must decide for himself. He appreciates fair treatment.

He is usually a hard man to sell, but a good man when sold. Be sure that your goods come up to representations and that they are delivered on time. If you make a mistake, do not offer an alibi. He admires the man who will take the blame on his own shoulders. Be straightforward and never waste time, either his or your own. Once you have proved your goods to be right, he will stick to you.

The Evolutionist

Appeal to the Evolutionist along the lines of education, progress, and beauty. He looks to the future and seeks improvement and innovation. He appreciates artistic, spiritual, and intellectual values. His urge for progress makes perfection his goal, and he is in the market for anything that will help bring him nearer this goal, regardless of price. He is interested in new ideas when they are worth while. He is a self-educator and investigator, and every new theory

Figures 13 and 14.



The Evolutionist
Triangular Face

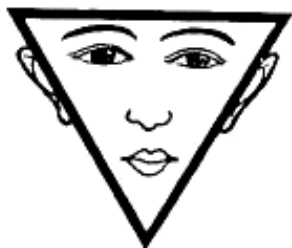


FIG. 13



The Evolutionist
Triangular Face



FIG. 14

interests him. He cares more for wisdom than for money or power. The Economist looks for the wrong in things but the Evolutionist looks for the good.

He welcomes acquaintance with anyone from whom he can learn something. He appreciates refinement and education and is repelled by coarseness and vulgarity. When talking to him, you can cover the ground with fair rapidity for his mind will keep pace with yours. His versatility and keen imagination enable him to see a thing from many angles. The more light you can throw on a subject, the better.

* * * * *

The Keynotes

To sum up each of the types discussed, the salesman may catalog them as follows:

The Commercialist -- Impressions and comfort.

The Economist -- Protection and power.

The Evolutionist -- Progress and wisdom.

NOTE:

Let me call your attention again to the fact that every human has all three Temperaments developed to some degree. You must learn to judge by proportion. For instance, you meet two round-faced men. One has a smooth, rounded nose and the other a finely chiseled, well developed nose. One has rounded facial features, the other is more angular. These two men are of the same Temperament but are different Sentimentally. The first belongs definitely to the Vital-Commercial stage, but the second has his vital characteristics and still has developed his will and mentality to a greater degree.

Now with the knowledge which I have given you, you can readily step from one appeal to another and vary it according to the reaction which you get. First, determine the predominant area on the face and then see how much of the other two is also used.

TYPES OF SALESMEN

We have been discussing the types of buyers. Now let us go to the other side and study the types of salesmen.

Salesmen can be divided into two great classes:

1 - High Pressure.

2 - Persuasive.

The High-Pressure Salesman

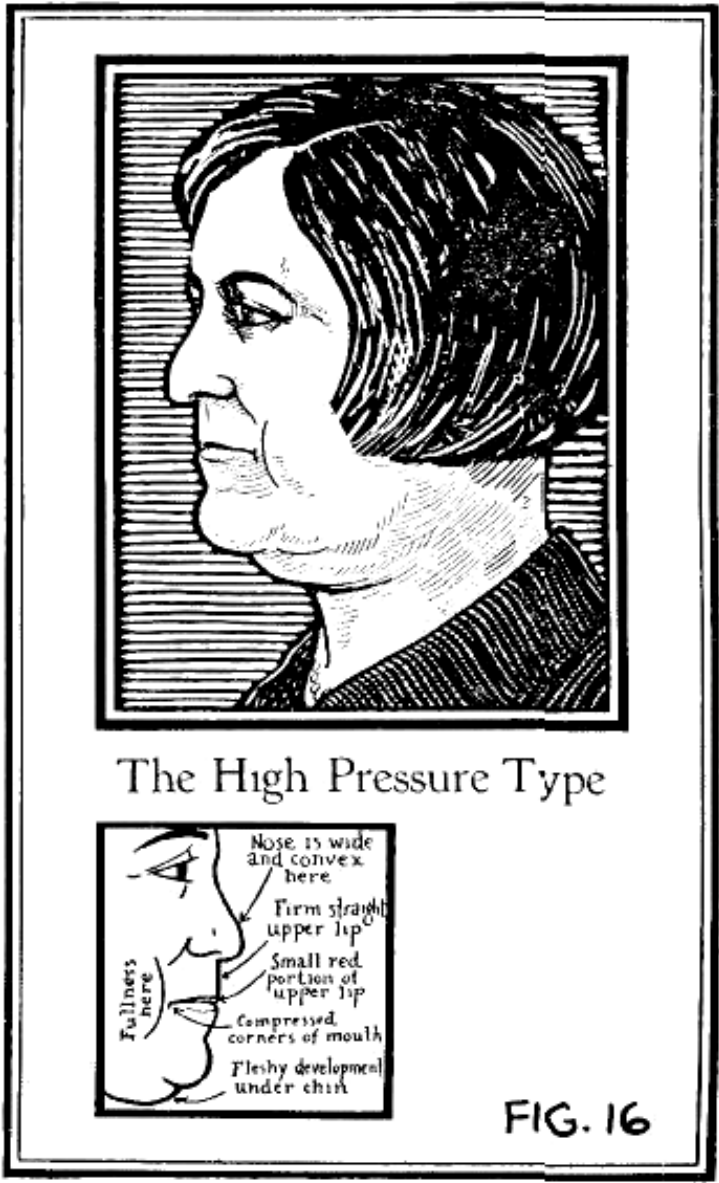
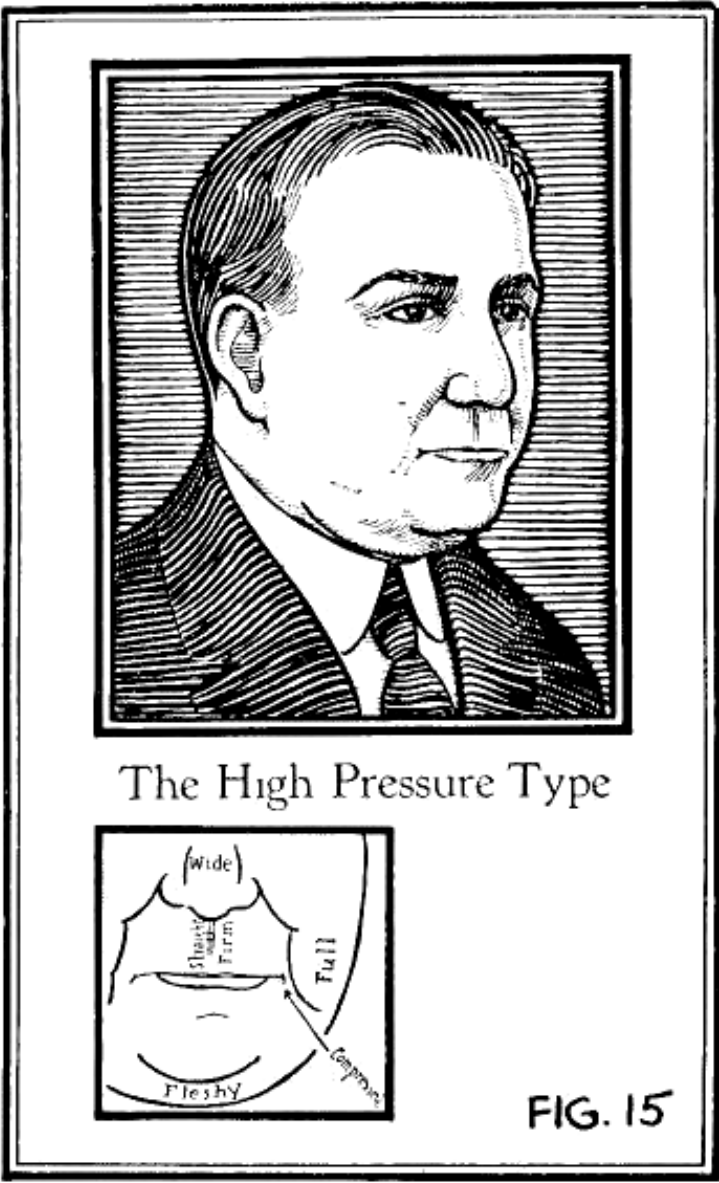
The High-Pressure Salesman is full of enthusiasm. He intensifies the prospect's desires and forces him to buy on

the spur of the moment. This kind of salesman rarely makes a second sale to the same customer because his sales are seldom satisfactory to the buyer. This salesman should be engaged in selling some particular service or goods which a customer buys only once. If he is engaged to sell some other kind of commodity or service, he usually finds himself out of place.

This type of salesman has an upper lip tightly compressed at the corners and is generally described as a man with a stiff upper lip. He is fleshy on each side of his mouth and is broad at the lower part of the bridge of the nose. He may or may not be heavily built but is generally inclined to stoutness. He likes to sit his prospect on a fence, so to speak, and then use force in his speech in order to convince. Once he has a prospect interested, he seeks to intensify desire to purchase and to purchase then and there. This man is good for real estate or specialty selling.

If this salesman doesn't make a sale on his first interview, he doesn't want to have anything more to do with the prospect. He gives him up, thinking that is the only wise thing to do. He believes all people are like himself and handles them accordingly, making no attempt to understand them. He either sells the man by forceful talk or pushes him off the fence in disgust and loses a possible customer. This salesman is a most eloquent talker. The danger comes when this salesman does not know the type of individual his prospect is. The Economist buys only of his free will and the Commercialist refuses to be rushed. If the latter is forced to buy on impulse, he usually cancels the order before it is filled. Thus almost any sale made by the High-Pressure type is unsatisfactory to the buyer and very profitable to the salesman.

Figures 15 and 16.



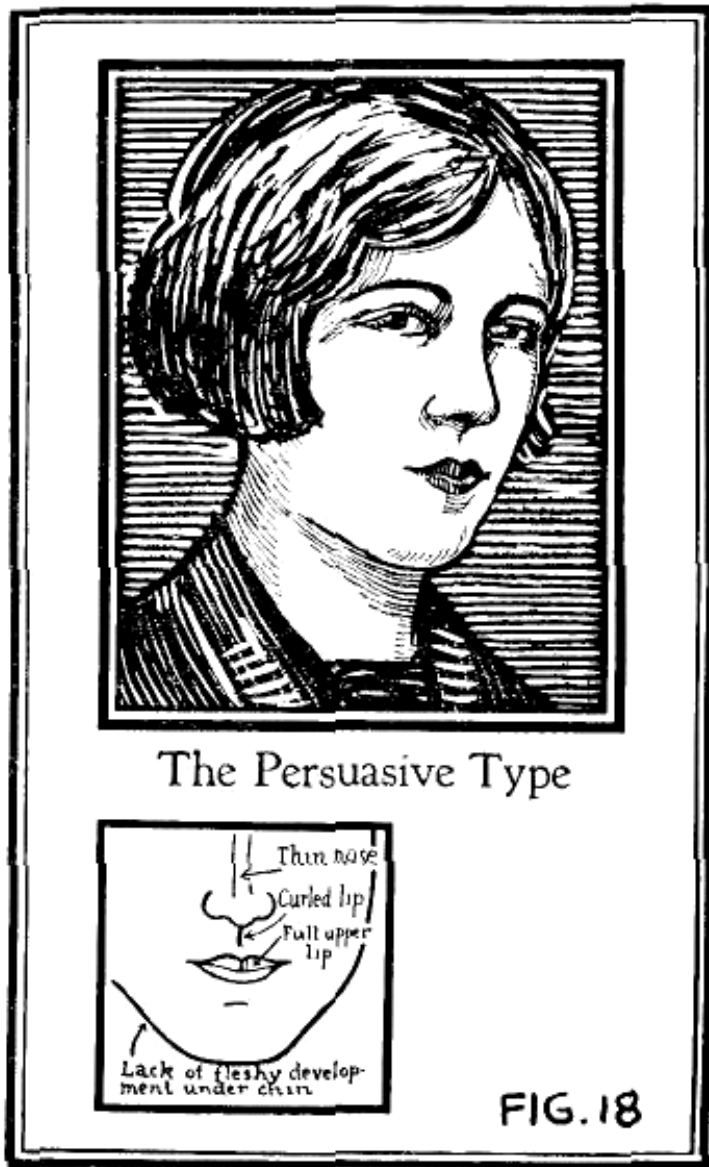
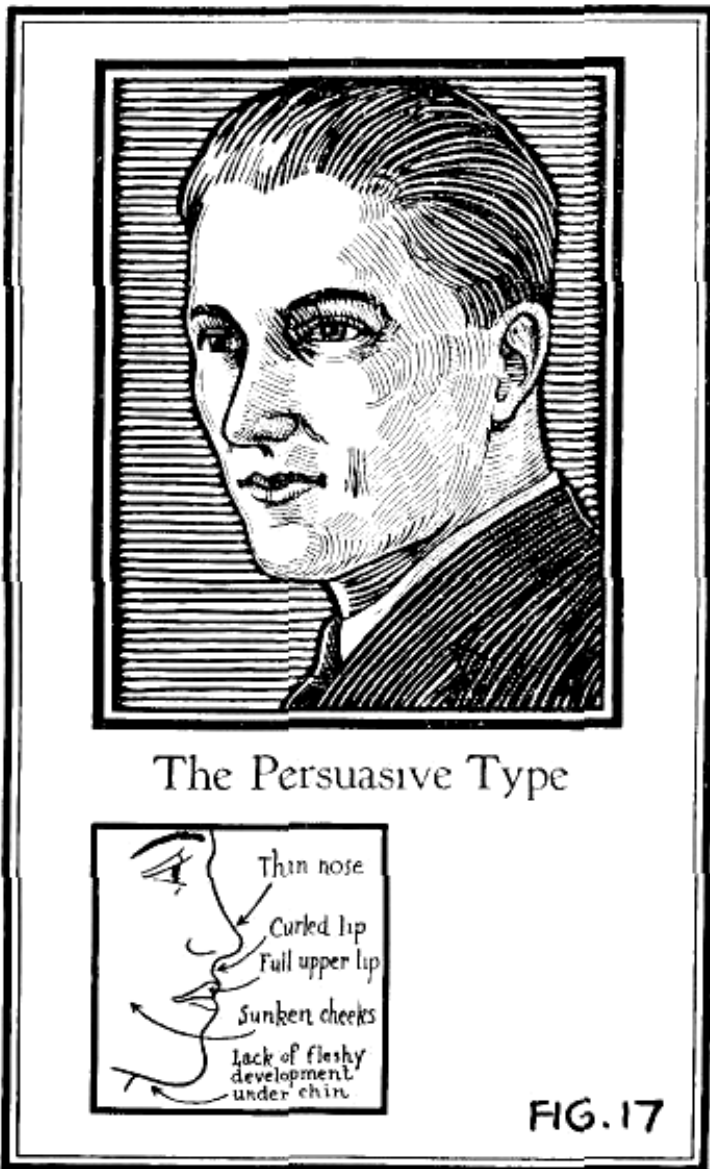
When a man is this type of salesman, he may belong to any of the three classes of buyers. You must study him according to your relation with him - as salesman or buyer.

The Persuasive Salesman

The other type of salesman, the Persuasive, has a well formed upper lip, a rather thin face with hollows on each side of his mouth, and is seldom a fat man. He likes to win his customer through kindness and hospitality and service. He must always be sold himself on the value of the commodity or service which he is offering to the customer before he can try to sell it. He believes that honesty comes first. He believes that if he represents a reputable firm and his commodity has value, he need not force it on anybody but merely explain the merits of the thing and it will sell itself. So he explains the value of his article and uses persuasion and friendship in his sales. If he doesn't sell his prospect right away, he believes he will do so on some subsequent occasion. He refrains from using force for fear that he will spoil his future chance to sell that prospect.

This man has little success in selling specialties or real estate, but is the best salesman for commodities of daily use where repeat orders are looked for. He should be employed in selling articles which are as represented and give full value. He makes a wonderful salesman in a department or jewelry store. If one could check over returned sales, it would be found that 95% of them were made by High-Pressure salesmen, for almost invariably when a customer buys from the Persuasive type, he remembers that nothing was forced on him and he is not likely to want to return it.

Figures 17 and 18.



Everyone who is selling anything should analyze himself to ascertain which type of salesman he is. Everyone who employs salesmen or buyers should study his men in order to place them in their proper positions for the best results.

Both High-Pressure and Persuasive Salesmanship have their places. It is well to know when to use one and when the other. One can use High-Pressure and still do a good turn for the customer. The ideal salesman is the one who combines both types.

In the show business High-Pressure is used to a considerable extent to awaken the emotions. When an audience is moved to laughter and tears and held in an emotional state, they are easily sold. Even the music in the theater is helpful in selling a performance. Extensive posters and advertising with well chosen words all have the element of High-Pressure. High-Pressure is thus in its proper place when you deliver the goods to support it.

Important in your work as a Magician is to use High-Pressure in keeping your spectators emotional and thus selling them the show -- and to give such a good show that they are eager to see you again.

In a performance High-Pressure is used to accent it and put it over with a wallop, intermingling it with Persuasive Salesmanship to give it balance, and make it lasting.

When doing a great deal of High-Pressure work, if you are a persuasive type and rather thin, be careful that you do not burn up too much energy and that you recuperate with plenty of sleep. Often a thin person, working under High-Pressure, tenses his muscles so severely that he has difficulty in relaxing them. A Naprapath, Osteopath or Chiropractor can aid at times in reducing the tension. A warm bath and physical exercises which loosen up the spine will help also.

I hope you will make a real study of the discussion which I have given you so that you may use this material in understanding yourself and other people better and will thus arrive at the success for which you are working.

* * * * *

ADDITIONAL PRINCIPLES AND EFFECTS IN HANDKERCHIEF MAGIC

There are many angles to Handkerchief Work, and in this lesson, I am giving you additional principles and effects. You will find the knowledge contained here invaluable to you throughout the rest of your life in Magic. Some of the methods you may not use for years, then all of a sudden when you are planning something new, one of the principles learned here may suggest just the thing you want. Many times you are

called upon to work under such peculiar conditions outside of your regular routined program that emergency methods are regular life-savers. Also if you are giving a number of programs before the same audience, a fresh supply of material is of the utmost value.

* * * * *

BLENDING OF THE COLORS

This experiment is a favorite with Dr. Milton Bridges of New York City. Dr. Bridges is a prominent physician and is an eminent figure in the Magic World. He possesses one of the largest magical libraries in the world.

Unlike the "Birth of Old Glory," described in your last lesson, this effect requires no special preparation. It also brings to light an important principle in Magic, known as VESTING. This term is common in the magical world, yet, strange to say, very few magicians know how to do it properly. Too many just take it for granted that they know. It has always been a pleasure to see Dr. Bridges' effects in which he uses the principle of VESTING. He performs them in a most graceful and effective manner. I shall teach you his method of VESTING.

EFFECT:

Performer picks up three silk handkerchiefs from the table and shows them, one at a time—one red, one white, one blue. He crumples them up in his hands and taking a corner of the blue and a corner of the red silk, he pulls them apart and shows that they have blended into a silk American flag. This effect may be adapted for use with the flag of any country. It works nicely after dyeing handkerchiefs in the paper tube, as taught to you in the preceding lesson.

PARAPHERNALIA:

1 -- Three silks -- 13 inches square.

One red, one white, one blue.

2 -- A silk American flag -- 12 x 18 inches or larger.

SECRET AND PATTERN:

To Prepare:

Fold the silk flag over in two as in Figure 19.

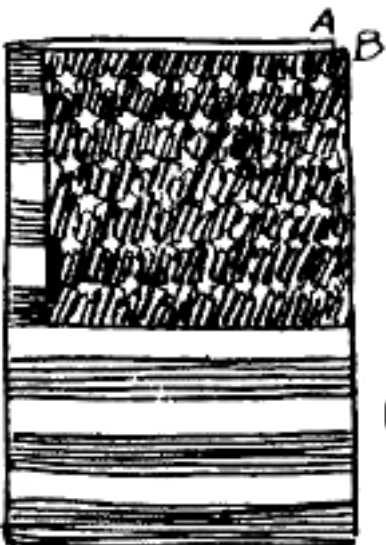


FIG
19



FIG.20



FIG.21

Fold in half again as in Figure 20. It is important in folding to keep the corners A and B together and on the outside.

Fold flag over again as in Figure 21.

Fold bottom up behind flag, about one-third of the length -- then up again to bring fold even with top edges of flag. Corners A and B are together and outside.

(40-18)

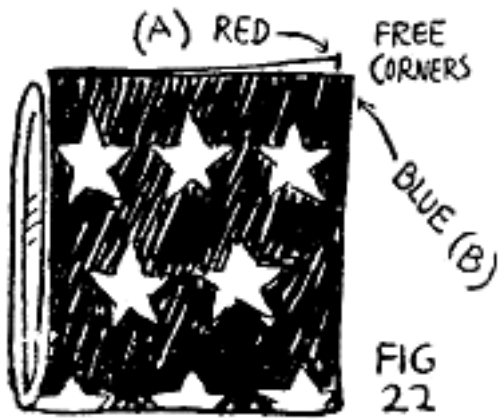


Figure 22.



Raise the lower left side of your vest and place the folded flag against your body with the blue side inward and the red side outward. Allow vest to fall down to cover flag completely. You will find that vest is tight enough to hold folded flag safely until needed.

Figure 23.

Have the red, the white, and the blue silks lying on the table. If you first perform the dye tube effect, pick up the red and blue silks and take an extra white one.

To Perform:

Pick up red silk with right hand and shake it.

"A red silk."



Place it in left hand and pick up white silk with right hand and shake it.

Figure 24.

"A white silk."

Place white silk on top of red one in left hand, then pick up blue silk and shake it with right hand.

"And a blue one."



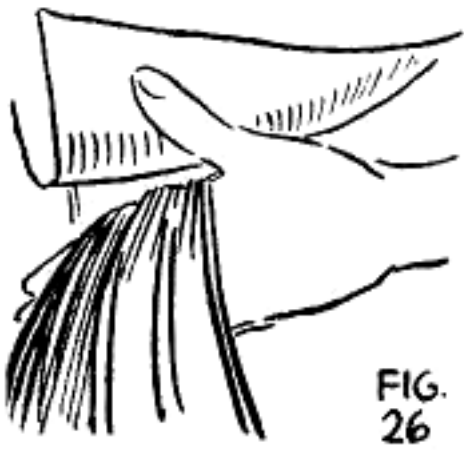
As you shake blue silk in right hand, reach up under left side of vest with left thumb. Turn bottom edge of vest upward, and with aid of left fingers get flag into left palm. The MISDIRECTION you use here is keeping the attention of the audience on the silk in right hand.

Figure 25.

THUMB TURNS EDGE OF VEST UP

Figure 26 shows a close view of your movements in securing the flag with left hand.

(40-19)



Slide your left thumb downward and let edge of vest fall into original position. Sliding of thumb will adjust vest correctly.

IMPORTANT:

This is the Principle of VESTING. Before you go any farther with this lesson, get a flag or piece of silk and practice this thoroughly in front of your mirror. Bring your left thumb up under vest and raise edge of vest just enough to get silk into hand. Then bring hand down again, adjusting vest at the same time. Keep your left hand almost flat but in a natural position.

Many performers try to reach up with their hands under their vests, but the easiest and least detectable way is to raise lower edge of vest with thumb, as taught to you above. Billiard balls, eggs, lemons, and other objects can be VESTED and produced in similar manner.



FIG 27

Flag is now concealed in left hand and behind other silks.

Figure 27 is view away from audience.



Place blue silk in left hand with the others. With right hand gather up the silks, crumpling them up in right hand.

Figure 28.

"I take a corner of the blue silk."

FIG 28

Pick up corner B (blue) of flag and expose it about half an inch.

"And a corner of the red one."

Pick up corner A (red) of flag and pull it out a short way.

"A peculiar thing about red, white, and blue is its power to blend."

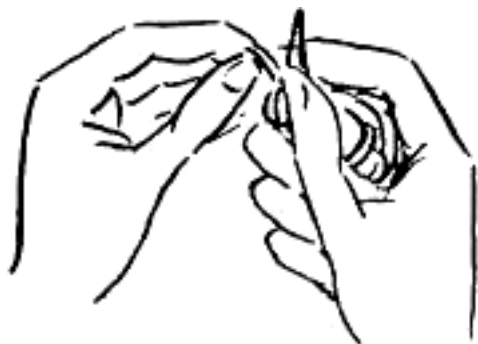


FIG. 29

Grasp A with left forefinger and thumb and B with right forefinger and thumb, or vice versa.

Figure 29.

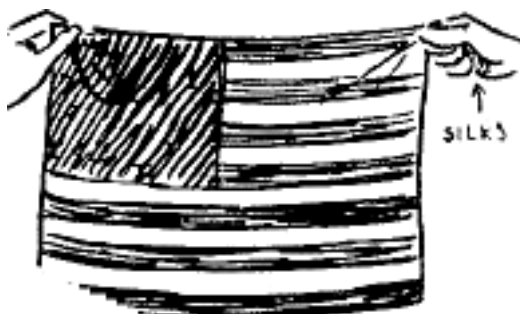


FIG. 30

Pull hands apart, allowing flag to open out. The three silks are concealed in palm of right hand.

Figure 30 is a view away from audience.

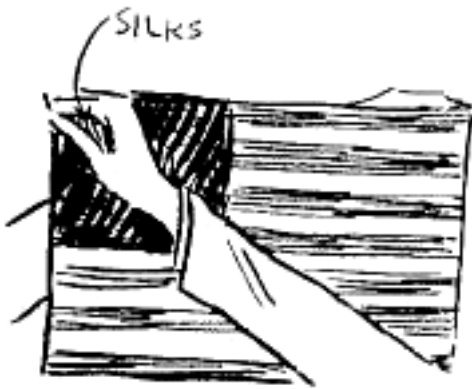


FIG 31

To show opposite side of flag, bring right hand back toward yourself and over to the left under left arm. This keeps right hand concealed behind flag. Left hand goes over to right and arm is in front of flag. Each hand retains its original hold on flag. You merely turn flag around to show other side.

Figure 31 is view as audience sees it.



FIG 32

Bring hands and flag back to position shown in Figure 30. Then hold flag in left hand. Reach under flag with right hand about at the center, allowing flag to fall over right hand. Grasp center of flag above with left hand, taking hold of the silks inside at the same time. Place flag aside with silks concealed inside of it.

Figure 32.

* * * * *

THE MYSTIC RIBBONS

This effect is easy to do. It requires little preparation and is effective.

EFFECT:

Performer shows three pieces of tissue paper, orange, green, and black. These are lighted with a match. While paper is burning, performer suddenly crumples it up and throws it out toward audience. Mysteriously it changes into three long silk ribbons. The ribbons are then gathered up. Suddenly Magician draws his hands apart and the ribbons have changed into a large silk with a butterfly or design painted on it.

PARAPHERNALIA:

1 -- A large, bright, orange-colored silk -- a yard or more square.

On this paint a huge butterfly with black and green and touched up with gold bronze. You can paint on silk easily by mixing Japan paint with a preparation called Permanent Mixture, which keeps paint from running. Paintex Colors are also satisfactory.

You may use a large flag or a silk dyed in various colors, if you prefer.

2 -- Three ribbons -- orange, green, and black -- each about an inch wide and ten or twelve feet long.

3 -- A small metal ring, large enough to slip over right thumb easily. Also two small metal rings for corners of large butterfly silk.

4 -- A safety match box, large size.

In order to accommodate plenty of silk, it is well

to have a tinner make a tin match box for you. Cover it with paper or paint it to represent an ordinary match box. Paste black emery paper on sides for striking matches and fill box with regulation size large matches. A box so made is substantial and will last a long time.

5 -- Three strips of colored paper to match ribbon. Each strip should be about an inch wide and a foot or so long.

6 -- A stationery clip -- can be purchased at almost any stationery store. It should be about an inch wide.



FIG. 33

Figure 33.

SECRET:



To Prepare:

On the two upper corners of butterfly silk, sew the two metal rings. Paint ring A red or some other color to distinguish it from ring B.

Figure 34.

Fold the silk as you did the flag in preceding effect, keeping corners A and B together and on the outside.

Sew one lever of stationery clip to left side of your vest, far enough back to be concealed by coat and yet within easy reach.

FIG 34



FIG. 35

Place folded silk in clip with rings on silk toward the front.

Figure 35.

Allow your coat to hang naturally and cover clip and silk.



FIG 36

Place the ribbons on top of each other evenly and sew the three top ends to the larger metal ring.

Figure 36.



FIG
37

Beginning with bottom ends of ribbons, fold up small enough to slip into end of match box easily when box is pushed out partially.

Figure 37.

Place folded ribbons in end of match-box. Ring is on top and next to rear end of box. Have box on table with loaded end away from audience.

(40-22)

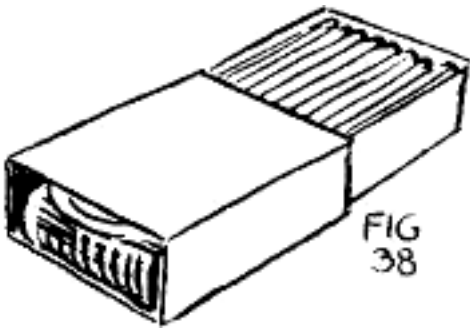


Figure 38.

Have the three strips of tissue paper nearby.

To Perform:

Pick up the paper ribbons, show each separately and then place them together in left hand. Pick up box of matches with right hand and place it in left with paper ribbons. Take a match with right hand and close the box, forcing folded ribbons into palm of right hand. This principle of getting a load from a match-box was taught to you earlier in the course.

Keeping back of right hand to audience, strike the match on side of box and then toss box aside.



Light top ends of paper ribbons and allow them to burn for a while. In the meantime, get ring of silk ribbons over right thumb.

Figure 39.

When paper has burned down a few inches, put flame out by blowing or striking with right hand. Crumple paper ribbons up with right hand and hold the ball secure in palm of right hand with third and fourth fingers of right hand.

Throw your right hand forward, releasing silk ribbons, which unfold and form streamers out toward audience. The ring over your right thumb keeps ribbon secure in right hand. Ball of paper ribbons is still retained in right hand. The moment you throw right hand forward, turn right side of body slightly toward audience and, pushing left side of coat back, pull folded silk from clip on vest. Keep silk concealed in left hand.

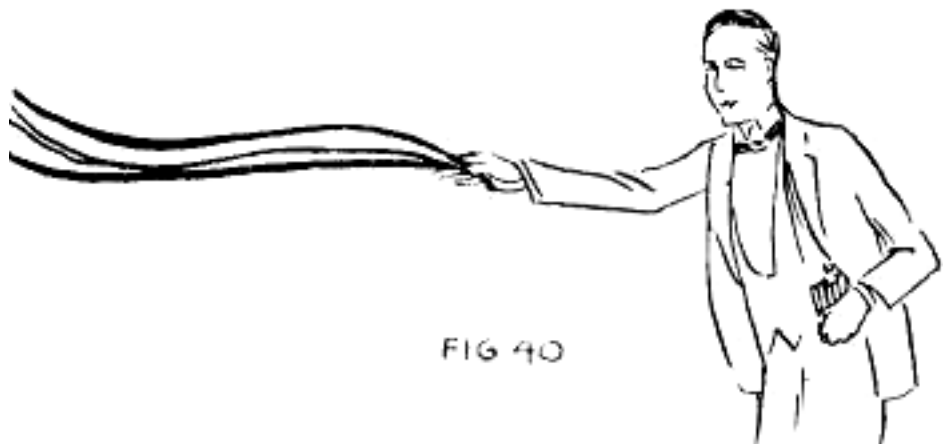


Figure 40.

Begin to gather up ribbons with right hand, bringing the first loop up to left hand. Continue gathering up silk ribbons, grasping the loops with left hand and concealing the folded silk behind them.

Figure 41.



Keep gathering up ribbons into a small parcel. At the same time, grasp ring A on silk with right hand and ring B with left hand. Pull hands apart suddenly, spreading out the big butterfly silk between them.



FIG 42

Figure 42.

You may conceal the silk ribbons or not, as you like. If you gather them up small and conceal them behind big silk, you have apparently transformed them into the big silk. Some performers do not gather up the ribbons very small and merely produce the silk from them -- thus accomplishing a production rather than a transformation.

* * * * *

THE PENETRATING POCKET KNIFE

This experiment appears to be entirely impromptu. It is puzzling and entertaining.

EFFECT:

Performer borrows a pocket handkerchief and has two spectators hold it stretched out between them by all four corners. He takes a pocket knife and places it under the handkerchief at about the center. Covering top of handkerchief with a piece of paper, he pushes the knife right up through handkerchief and paper and pulls it out of the top. Handkerchief is then shown unharmed and knife and paper are given to spectators for examination.

PARAPHERNALIA:

- 1 -- A borrowed handkerchief--man's size.
- 2 -- A pocket knife.
- 3 -- A piece of newspaper or opaque wrapping paper, about ten inches square.
- 4 -- A small nail--three penny or less.

SECRET AND PATTEN:

To Prepare:

Finger Palm the small nail in right hand. It is easy to conceal for fingers can be closed naturally over it to hold it in place as you grasp knife in same hand.

Figures 43 and 44.

To Perform:

Borrow a man's handkerchief and have two spectators hold it out between them by the four corners. The ANGLE OF VISIBILITY is important to watch here. If audience is all around you, have handkerchief in horizontal position. If audience is in front of you, have handkerchief in vertical position. Spectators must not see what goes on under or behind handkerchief.

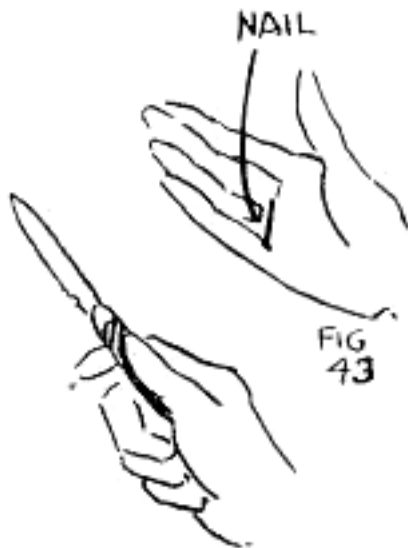


FIG 44

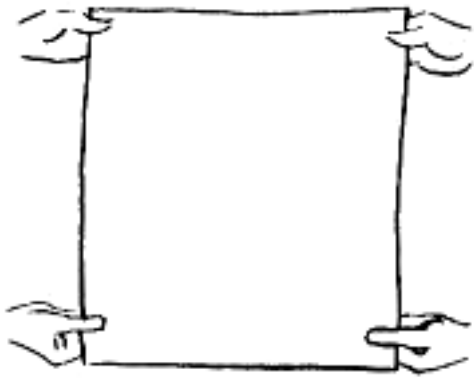


FIG 45

Figure 45.

Borrow a pocket knife or use your own. Hold it in right hand with nail Finger Palmed.

See Figures 43 and 44.

Take sheet of paper in left hand.

Say to a spectator:

"Do you believe in the theory of solid through solid or the ability to walk through your front door at night without opening it? Such knowledge exuberates me. That's why I have asked the two gentlemen here to hold this handkerchief stretched out in plateau fashion rather than in parachutic style. Also that's why I use this pocket knife and this piece of paper with two sides between the edges."

Show knife and also paper on both sides, to show that you have no trick material.

"Now if I place the knife under the handkerchief and push up with the point of the blade, it makes a small mountain in the wide stretch of handkerchief."

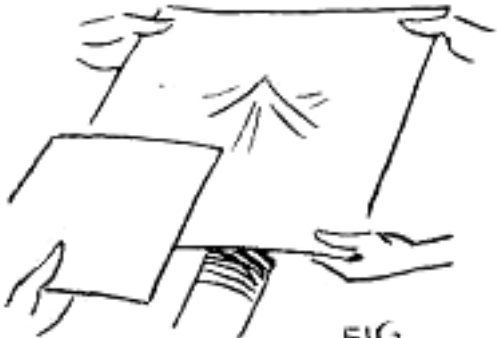


FIG. 46

Place knife under handkerchief in center and push up a little to prove that point of blade is actually there. Hold paper in left hand over rear left-hand corner of handkerchief.

Figure 46.

Withdraw knife and show it above handkerchief.

"I could push the point of the blade down on the center of the handkerchief from this side, but then the mountain would be on the other side."

Demonstrate this as you say it.

"You really get a better view of the mountain scenery from underneath."

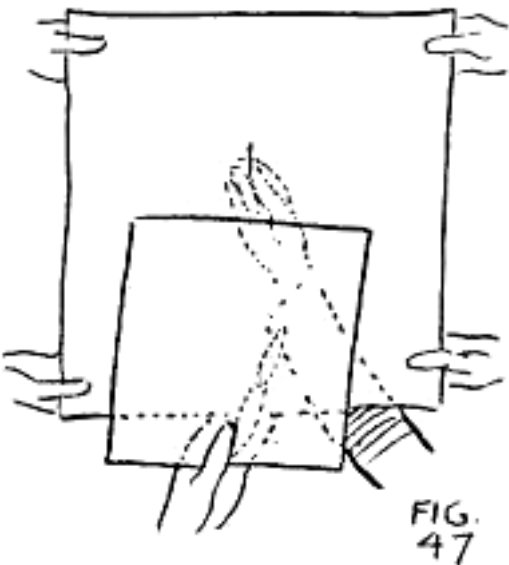


FIG. 47

This time as you place knife underneath center of handkerchief, bring the paper over to middle of rear edge. As you get knife under rear edge of handkerchief, grasp it with left fingers and hold it against the paper. Move right hand to position under center of handkerchief, get nail quickly to finger-tips and push pointed end of it up under handkerchief as you did with the knife before.

Figure 47 shows a diagram of your movements.

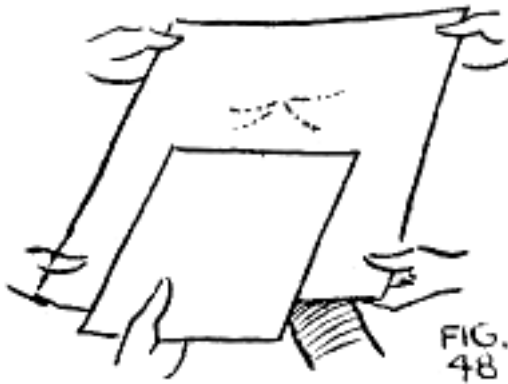


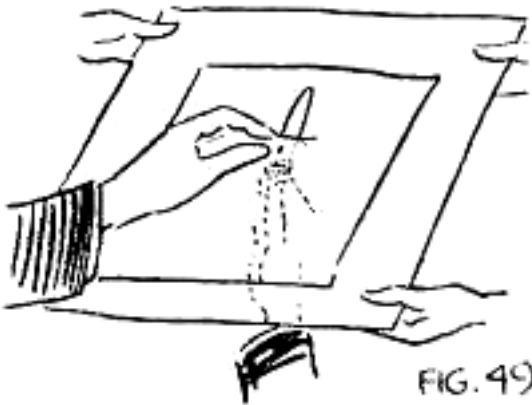
Figure 48 is a view as the audience sees it.

"I shall temporarily cover the center of the handkerchief and the mountain with this sheet of paper."

Bring paper back a little to clear knife from under rear edge of handkerchief. Then place sheet of paper with knife concealed under it on center of handkerchief.

Grasp handle of knife at the end through handkerchief with right hand.

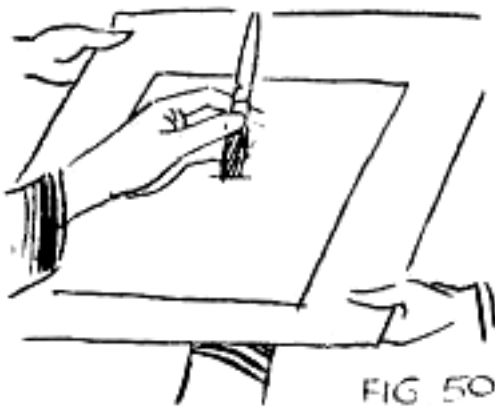
"By giving the knife a slight push, the point of the knife comes through the handkerchief only about a thousandth of an inch, but if I push harder, the whole blade comes through --this being a sharp knife."



As you say this, push point of knife through the paper as you hold paper down with left hand. Knife is easily controlled through the handkerchief by right hand.

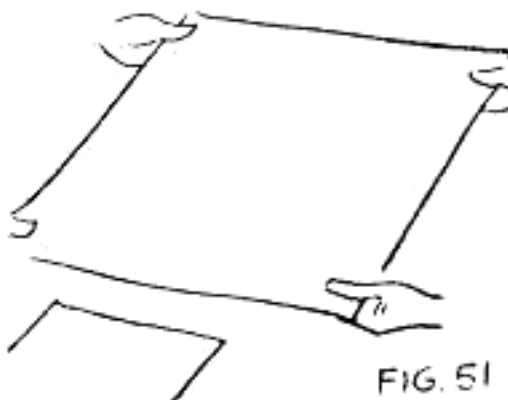
Figure 49.

"And if I keep on pushing, the whole knife comes through."



Pull knife out through top of paper with left hand.

Figure 50.



Remove paper and show it on both sides. At the same time, remove right hand from underneath the handkerchief with nail Finger Palmed. Show handkerchief unharmed.

Figure 51.

"Of course, the handkerchief isn't hurt any because this is a borrowed handkerchief and I promised that no harm would come to it."

NOTE:

Be sure that when you remove right hand from underneath the handkerchief, you show it in such a way to convince audience that a duplicate knife is not used. You can keep nail Finger Palmed and still show hand freely.

VARIATIONS:

In emergency, part of a toothpick can be used instead of a nail.

Or forefinger or little finger may be used if finger nail is long and a bit pointed.

Or you may even use blunt finger. In this case, I first show effect of point of blade against handkerchief, then reverse knife and show effect of pushing end of handle against it.

After I have knife in left hand under paper and have right hand under center of handkerchief, my Patter runs something like this:

"There is really no danger in pushing against a handkerchief with the handle end of a knife."

Push handkerchief up from underneath with tip of one of your right fingers, then cover it with paper.

"But there is some danger when the point of the blade is used, as the blade might accidentally come right through the handkerchief and the paper."

As you say this, push knife up through paper. Conclude experiment as above.

THE INDESTRUCTIBLE HANDKERCHIEF

I do not know where this mystery originated. I have seen a number of versions of it. My first apparatus came from England. I had another method from France. Floyd Thayer of Los Angeles, California, has perfected a piece of apparatus that is really beautiful. It is easy to work, substantially built, and not detectable. With this apparatus the effect is most puzzling for it can be worked with people all around the performer.

EFFECT:

A lady's handkerchief is borrowed, stretched across a wooden frame, and held in place by thumb tacks at each of the four corners. The frame and handkerchief are placed inside an examined paper envelope. A butcher knife is suddenly thrust through the center of the envelope and pulled out of the opposite side. Again and again the knife is plunged through various parts of the envelope. The Magician even pulls other objects through the holes, such as a cane or a handkerchief. The envelope is then opened and the frame withdrawn. The handkerchief is unharmed and still stretched tightly across the frame.

PARAPHERNALIA:

1 -- A lady's handkerchief -- borrowed.

2 -- A special wooden frame.

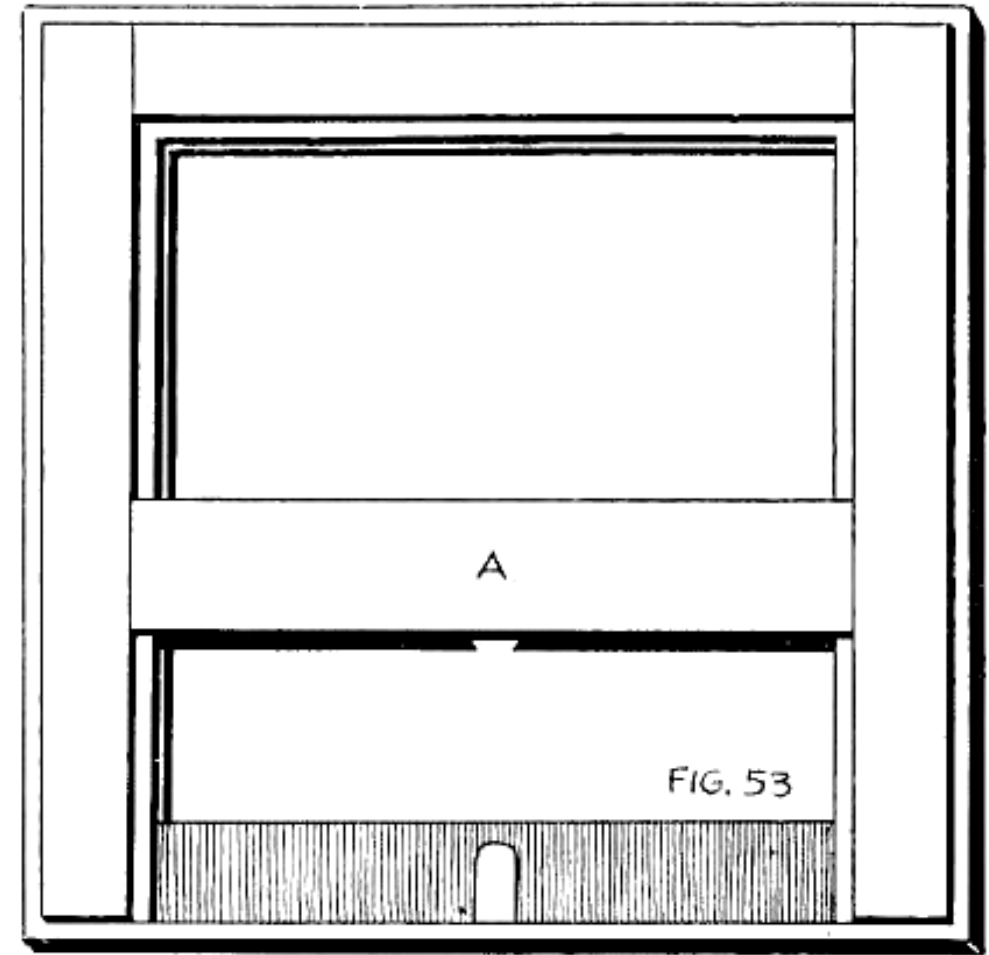
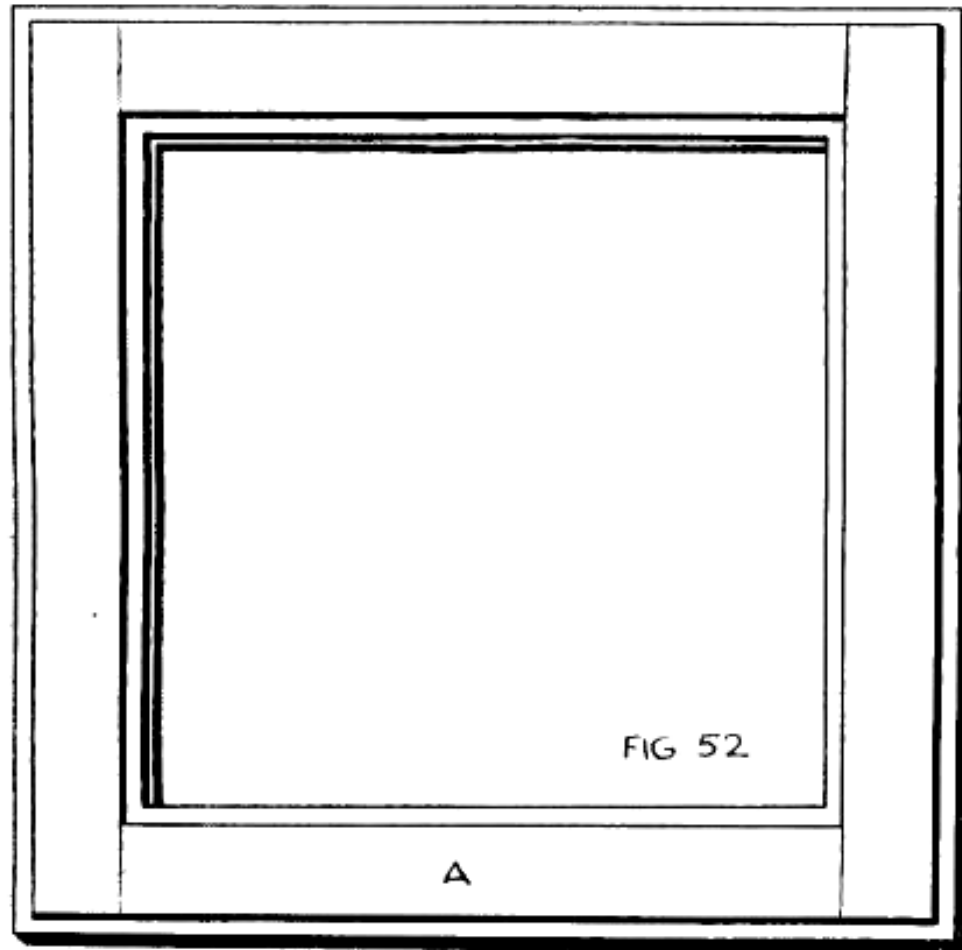
We can furnish you with a frame at a reasonable price. See Price List.

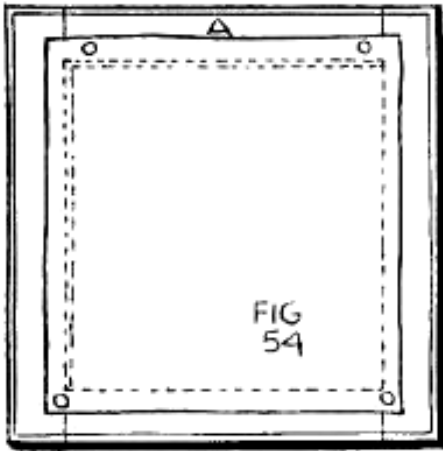
The frame is 12 1/2 inches square. The edges are an.

inch and a quarter wide and five-eighths of an inch thick.

Figure 52 shows the frame as it looks to the audience. It appears to be just a square wooden frame with a large opening in the center. It appears to be merely something over which to stretch the handkerchief with room on the edges for tacking it down.

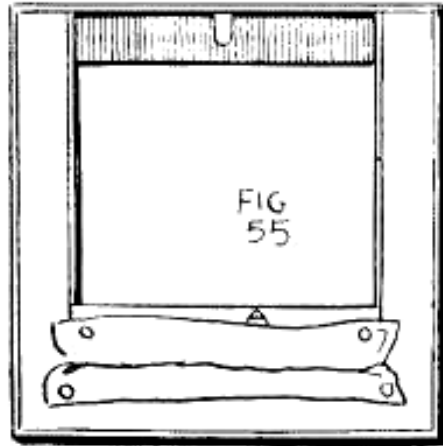
Figure 53 shows the actual construction of the frame. It is built so that the outside edge of the frame is left intact but part of one side slides up and down.





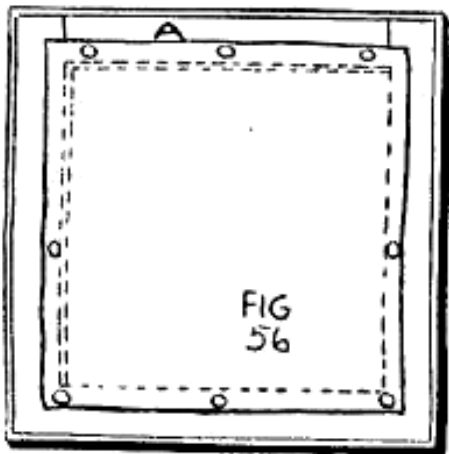
When a handkerchief is tacked on the frame, two of the tacks are placed on the sliding edge and the other two at the opposite end on the stationary edge.

Figure 54.



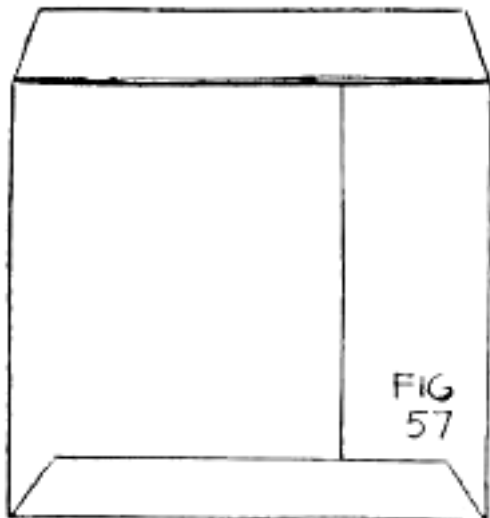
The sliding bar can then easily be pushed down. It carries the top edge of the handkerchief with it and leaves an open space through the frame.

Figure 55.



Bar A can be pushed back into place when necessary and the handkerchief will be stretched tight across the frame as if it had not been disturbed. Eight thumb tacks may be used in some cases instead of four. This does not allow so large an opening but it is a good method under certain circumstances. Be careful to place middle thumb tack on bar A a little off center so that it will not penetrate the raised guide bar.

Figure 56.



3 -- A heavy, opaque paper envelope -- about 14 1/2 inches wide and 13 1/2 inches long. You can easily make this envelope from manila wrapping paper.

Figure 57.

4 -- Fairly large thumb tacks.

5 -- A butcher knife. Also a cane and silk handkerchief, if desired.

SECRET AND PATTERN:

To Perform:

Have thumb tacks, envelope, frame, and butcher knife handy.

Pick up frame.

"This was suggested by experiments worked out in the art galleries of France. It is, therefore, necessary for me to construct an imitation oil painting. This wooden frame will answer the purpose of the frame of the picture, but we also need a canvas. For this purpose, I should like to borrow a lady's handkerchief."

Borrow a handkerchief which will fit over frame. Come back to table, keeping handkerchief in sight of audience all the time.

"Naturally, canvases are tacked on frames. We will have a short delay now while I tack this handkerchief on this wooden frame."

Tack handkerchief to the frame by the four corners, placing two tacks on the sliding bar A and two at the opposite end. See Figure 54.

Hold up the frame and handkerchief so that spectators can see them.

"It looks like the beginning of a beautiful painting. Now in the art galleries special bags were constructed to fit each painting. Would you mind, sir, opening this bag and examining the inside to see that nothing is hidden, such as a can of paint or a few brushes? You find nothing, sir, nothing but the inside of the bag."

As you say this, give paper envelope to spectator and take it back after he has examined it.

"Every evening the paintings are placed in these paper bags."

Place the frame with the handkerchief in the envelope so that audience can see it go in. Be sure that bar A is at top. When frame is about two-thirds of the way in, turn handker-

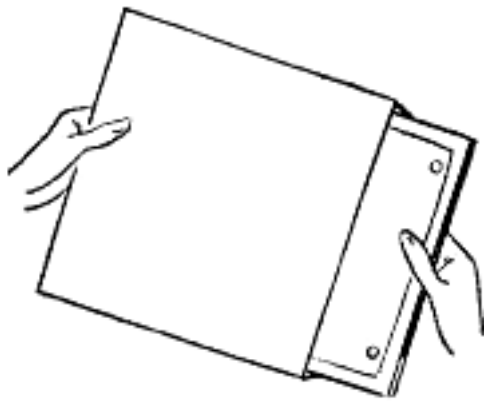


FIG. 58

chief side toward yourself and continue pushing frame into envelope.

Figure 58.

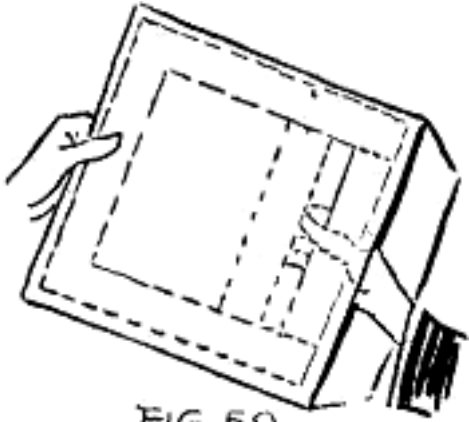


FIG. 59

The moment bottom edge of frame touches bottom of envelope, push bar A down a few inches with right thumb.

Figure 59.

Bring bottom of envelope down, allowing bar A of frame to slide to bottom of frame. Close flap of envelope.



FIG 60

Pick up the butcher knife and strike all four sides of the frame to prove that it is in the envelope.

Figure 60.

"All's well within."

Hold envelope and frame in left hand and knife in right.

"The reason for it all is this. It seems that for some reason or other many fine paintings in the galleries were being destroyed. The paintings were often found slashed to shreds. Whether it was the work of jealous artists or vandals was not fully established. However, the damage was done. Why, it was nothing to have someone push a butcher knife right through a canvas."

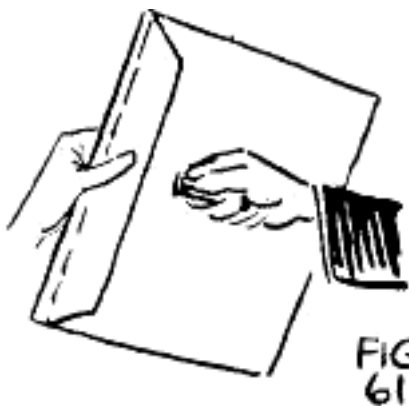


FIG 61

As you say the last sentence, quickly run the end of the knife through the envelope a little above the center from the rear to the front.

Figure 61.

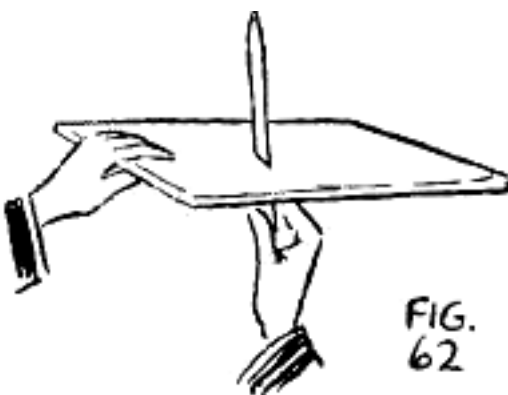


FIG. 62

Show knife sticking through both sides of envelope. This gets a good laugh for audience thinks the handkerchief has been cut.

Figure 62.

"Sometimes there were many slashes in the canvas."

Remove knife and run it through envelope at several safe places.

At this stage, you can push a cane through one of the holes or push a silk handkerchief through a hole, pulling it out the opposite side.

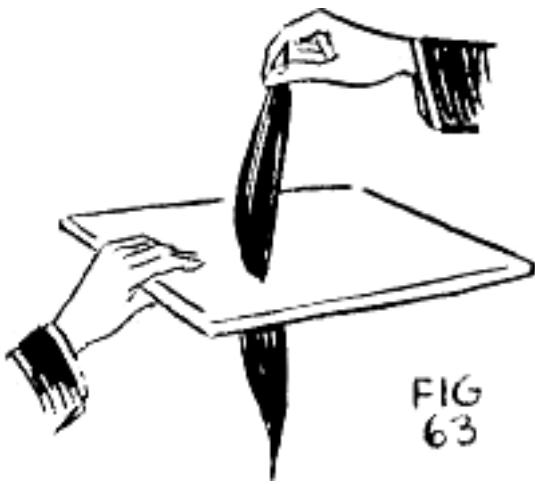
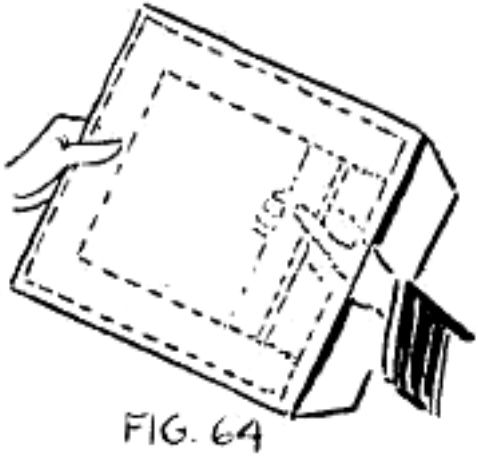


Figure 63.

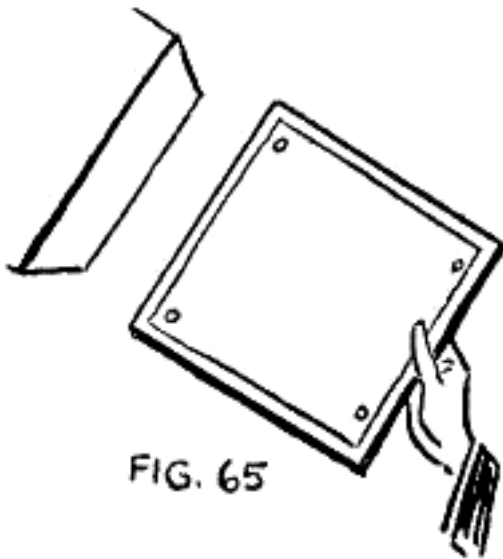
"You do not mind, madam, if I make holes in your handkerchief for the sake of the cause. The laundry would do it eventually anyhow."

Place knife, cane, and handkerchief aside on table.



Open paper envelope and turn it with opening downward so that sliding bar will fall toward top of frame. When it is within reach, grasp it with right hand and pull it into place, thus stretching handkerchief over frame again.

Figure 64.



"Well, when these magic bags were discovered and the pictures placed in them, the boys could slash all they wanted to."

Remove frame from bag and show handkerchief unharmed.

Figure 65.

"For, strange to say, the pictures were unharmed."

Remove the tacks and lay tacks and frame on table. Take handkerchief back to lady from whom you borrowed it. Roll it up in your hands and pretend to place it in your left hand, keeping it concealed in right. Reach over with left hand and pretend to give handkerchief to lady. The spectators laugh when they see that handkerchief has vanished.

"Oh, pardon me, the gentleman here has it."

As you say this, reach inside gentleman's coat and produce handkerchief with right hand, unwinding handkerchief as you pull it out. Return the handkerchief.

"Bags like the one I used could be worn over the stockings and would save considerable darning."

SUGGESTION:

When working with children, a funny effect may be obtained in this way: Give bag with frame inside to youngster to hold horizontally. Place butcher knife in his right hand and have him hold it point downward over center of bag. Tell him to drop it when you count three. You count three and he drops knife, causing it to fall through paper to the handle. You look surprised and say,

"Pardon me, I meant for you to drop the envelope, not the knife."

Then continue effect.

A handwritten signature in cursive script that reads "Harlan Tarbell". The signature is fluid and elegant, with a prominent flourish at the end of the name.

TARBELL SYSTEM, INCORPORATED, Chicago.

LESSON 41

A great lesson for you in Billiard Ball Manipulation. Billiard Balls play a prominent part in Magic and I want you to have a knowledge of this work. Good principles and interesting effects will be taught to you.

(40-32)

BILLIARD BALL MANIPULATION

For many years the billiard ball has been popular in Magic, but its use has been more for manipulative display than for natural Magic. Because of its shape, it offers many possibilities in sleight of hand and hundreds of different sleights have been devised by Magicians. These moves take a great deal of practice to perfect – hours and hours of practice. I could teach you these moves but prefer to give you MAGIC with Billiard Balls.

In this lesson I shall teach you principles for working with billiard balls. These are worked out with natural moves and require far less skill and practice than the complicated sleights. From the standpoint of the audience, they are just as effective and, in some cases, more so.

I want to emphasize the need for simplicity and NATURALNESS in your work. The more natural your moves, the better is the effect for it increases the element of surprise to the audience. Magicians waste too much time in studying out difficult methods of production, transformation, and vanishing. The effect to the audience is the same as if they had used simpler methods. Remember that the audience is interested only in the results – the effects you produce -- and it is up to you to produce them in an artistic, easy manner.

If you vanish a billiard ball, do it in the easiest, most natural manner possible. The same holds true in producing a ball. Pick out the method best adapted to your individual style of working, but keep it simple. It is only the beginner who makes things complicated. The great artist strives for quality rather than quantity and brings everything down to its simplest, most natural form.

I wish that you might see and study the billiard ball work of Cardini, the great English Magician. He has studied his work so thoroughly that he has succeeded in eliminating every unnecessary movement. Each of his productions and vanishes are done so easily and naturally that each has in it the greatest element of surprise.

Another marvel with billiard balls is Dante (Herr Jensen). He has developed many difficult moves. For instance, four balls suddenly appear between the fingers of his right hand at once. Magicians would sit and gasp at his manipulative skill, yet Dante has discarded most of the difficult moves for the simpler, natural ones for he finds that the latter are more entertaining. After all, you are entertaining your audience, and it is only those things which have entertainment value which will impress them. The most difficult manipulative methods are often lacking in this and consequently are better not used.

It has taken time to write this lesson on Billiard Ball Magic for you. No one will appreciate this more than the master magician himself, who can judge by comparative values

gained in years of study of manipulative work. The beginner is new to the subject and has no standard of comparison or contrast by which to judge. Too often, he takes it for granted that things in Magic are common knowledge and he also makes the mistake of thinking that simple things need not concern him.

It will take years for the new man in Magic to appreciate the real value of the methods given in this course and of the tremendous saving in labor and in money which it will mean to him.

Thurston, the famous Magician, and I were talking one day about Magic and success and he said this: "The world will never know the hard work and many hours I have spent to make my show a success. I had to get an idea here and another there - I had to spend many dollars and burn the midnight oil to study what would be accepted by an audience and what would not. Had I been able in the early days to get the training which you are now giving to your students, it would have saved me dollars and years of experimental work which could have been put to better use."

And a similar story is told by the other great Magicians. And it is because they realize the great value of this course that the finest minds in Magic have cooperated with me to HELP YOU. For this lesson, Cardini, himself, came into my studio and posed for many of the sleights with billiard balls which I teach you in this lesson.

* * * * *

THE ROUTINE WITH BILLIARD BALLS

Instead of just teaching you the various sleights with billiard balls, I have worked up a routine with them so as to get dramatic action, so important in good entertaining. Into the first series of manipulations I have woven a story to account for the appearance and disappearance of each ball.

In this work, watch your angles carefully. Also do not forget that your audience must see every move. You must be careful not to hide your moves behind your body and, by all means, avoid facial contortions in performing sleights. As Cardini says, "Entertain your audience -- and not yourself."

Now to help you time your work, keep in mind the psychological reaction of your audience as you vanish and produce each ball. This is the reaction you get: When you vanish the ball, the minds of your audience say, "Gone," and then add, "Where is it?" You produce the ball and they say, "There it is," - then finally, "How did he do it?" You must also react in accordance with the way your audience reacts.

* * * * *

ADAM AND EVE

EFFECT:

A story is told about Adam and Eve and illustrated with billiard ball manipulations. During the tale, four bright

red billiard balls mysteriously appear between the fingers of the right hand, one at a time, and as mysteriously vanish again.

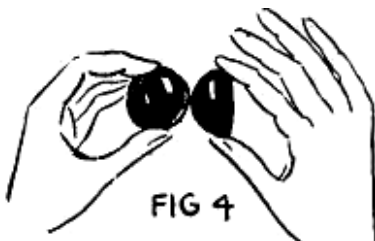
PARAPHERNALIA:

1 -- A Professional Set of Billiard Balls. This consists of three bright red solid wooden balls and a half shell which fits over any one of the balls.

Figure 1 shows a ball, Figure 2 the half shell, and Figure 3 the way in which the shell fits over the ball.



The Half Shell has made billiard ball manipulation easy and very mysterious. The audience believes that you use only solid balls and is never aware of the half shell. When viewed from the front, the shell looks like a billiard ball. If you hold a ball and a half shell side by side, it is impossible to tell the difference between them. The shell should fit snugly over the ball so that shell and ball look like one ball. With the ball in motion and at a short distance from spectators, edge of shell is not noticeable.



The shell must be loose enough so that ball will slide out of it easily. With a shell over a ball, you have one ball. When shell is suddenly lifted from ball, it appears that you have two balls. Thus you may show one or two balls at will. When shell is struck at the center with solid ball, it sounds as though two solid balls were struck together. Figure 4 is a side view, illustrating the manner in which this is done.

The most popular size of balls is 1 3/4 inch. For boys or those with very small hands, the 1 1/2 inch size is better. The larger the ball used the better the effect, but you must use a size which you can handle successfully. Cardini uses a 2 1/8-inch ball, varying with a set of 2-inch size. His hand is only medium size, but his manipulative training enables him to use a large-size ball.

We can supply you with the 1 3/4-inch size balls, red in color, unless otherwise specified.

2 -- A colored silk handkerchief.

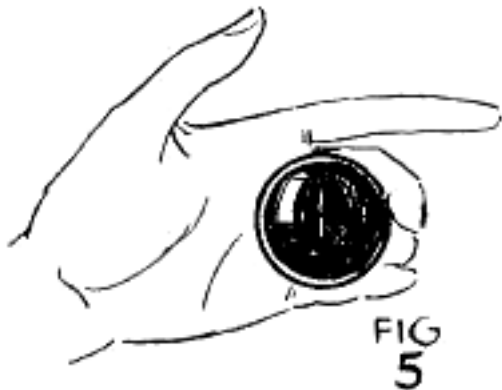
SECRET AND PATTERN:

To Prepare:

Place a ball with shell over it in rear right trousers' pocket. Place another ball in front left trousers' pocket or

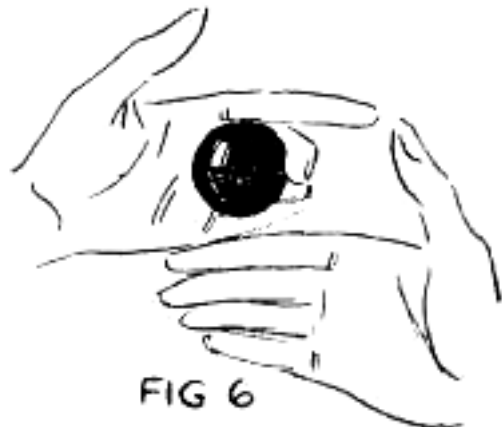
in lower left vest pocket. Place third ball in left coat pocket, together with silk handkerchief.

To Perform:



Get ball out of left coat pocket and Finger Palm it in left hand. You can do this easily under pretext of placing some object in pocket after finishing another trick. Or you can place your left hand in pocket casually and remove the ball without attracting attention.

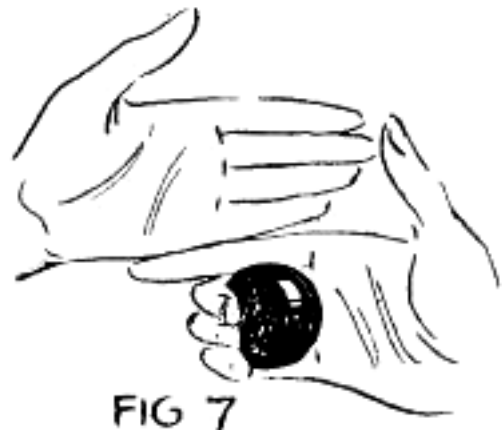
Figure 5.



Hold left hand in front of body in natural manner at about the height of lower vest button.

Bring right hand up under left. As you do, turn right side of body slightly to audience.

Figure 6.

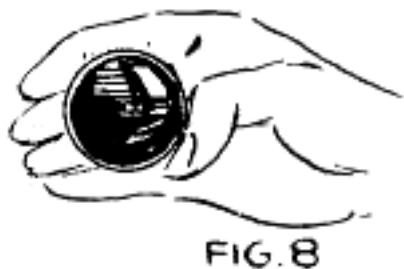


Let ball drop into right fingers where you Finger Palm it.

Figure 7.

Bring left hand away from right and show empty palm to audience. You have performed the Change Over Palm. You have apparently shown both hands empty. The larger movements of turning body from right to left helps cover actual movement of hands. This Change Over Palm may be used in transferring ball from one hand to the other as occasion demands.

"In the beginning, the Lord created the world."



Get thumb under ball in right hand.

Figure 8.



Bring ball quickly to top of hand, closing fingers to make a fist.

Figure 9 is a view toward yourself.



Figure 10 shows hand and ball as it looks to audience.

"And the world....."



Place left hand in front of ball.

Figure 11.

As you close left hand around ball, allow it to drop into right hand, where it is Finger Palmed again.

(41-4)

Figure 12.



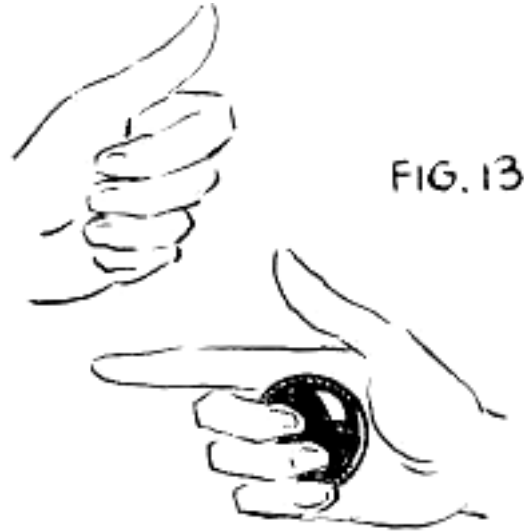
Move closed left hand, apparently holding the ball, away from right and hold it away from body with back of it to audience.

Figure 13.

"Wandered around....."

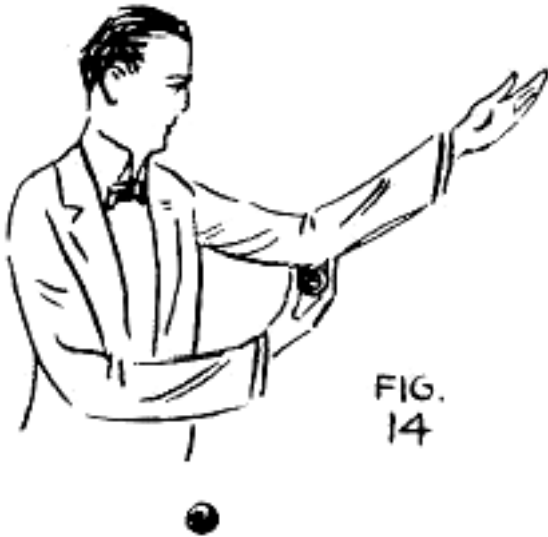
Turn left hand with palm side toward audience.

"Hither....."



Open left hand and show that ball has vanished. Reach up under left elbow with right hand and produce ball suddenly from elbow. To make this production and others from elbow, knee, etc., bring hand up with back to audience, then turn it, showing palm, and make production.

Figure 14.



"And thither."

Turn left side of body toward audience. Throw the ball into the air a few feet.

Figure 15.





Catch ball in palms of hands. Repeat. Then pretend to throw ball up a third time, but merely make the motions and keep ball palmed in left hand.

Figure 16-17.

The illusion is that the ball has vanished in mid-air. In throwing up hands, be sure that right hand comes up about a foot higher than the left. This makes the vanish more effective for audience can easily see empty right hand.



Figure 16.



"To keep the world in place, the Lord made Adam."

Produce ball at top of closed left fist.

Figure 18 shows performer as he appears to audience.

"But Adam....."

Hold ball on fingers of left hand in full view of audience. Thumb is nearest audience.

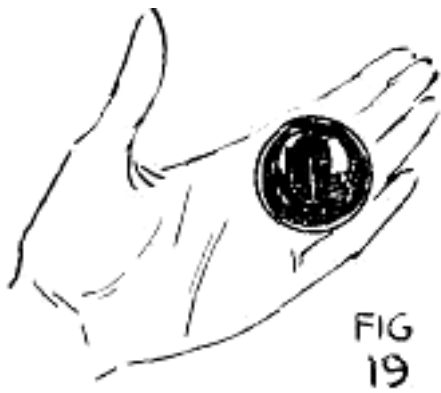
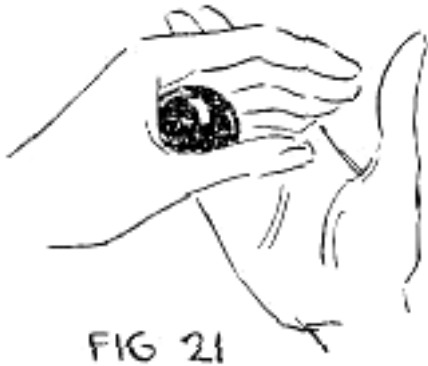


Figure 19.



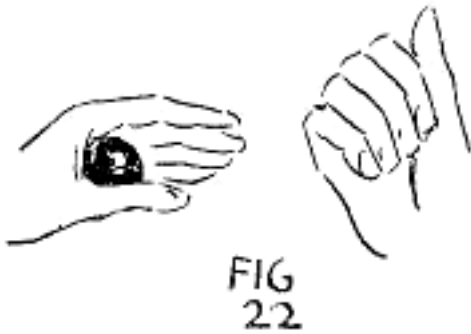
Bring ball over to right hand and apparently place it there.

Figure 20 shows movement as you see it, and not as audience sees it.



As you close right fingers supposedly over ball, Finger Palm ball in left hand. Turn palm of hand downward, and as you do so, push ball into position between palm and thumb.

Figure 21 shows view away from audience.



Right hand is carried away as though it contains the ball. Left hand is kept with back to audience to conceal ball.

Figure 22.



Pretend to toss ball into the air with right hand. Open both hands and hold as in Figure 23. Palm of right hand is exposed and left fingers are straight out, giving impression that left hand is also empty.

"Was a worse rounder than the world itself."



Produce ball from inner side of right knee with left hand. Hold ball on left fingers.

Figure 24 shows hand as audience sees it.



Place right hand over ball. This view shows hands as audience sees them.

Figure 25.



Turn left hand with back to audience. Pretend to take ball with right hand, twisting hand over so that fingers extend to right.

Figure 26.



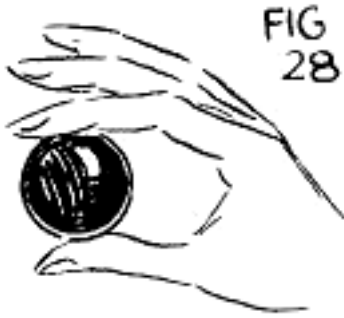
Carry right hand away, closed and with back to audience. Move hand upward and turn left side of body slightly to audience.

Figure 27.



Turn right palm to audience and show hand to be empty and ball to have vanished.

"You could never tell where Adam was. Pardon? I understood someone to say that he wandered around to my pocket."



Reach into rear right trousers' pocket and remove the ball with shell over it in right hand. Hold between thumb and forefinger so that front of shell is exposed to audience and edge is concealed.

Figure 28.

"Yes, there's Adam."

Your left side is to the audience and you have a ball palmed in your left hand. With thumb and forefinger gripping edge of shell on ball in right hand, turn right hand upward to show palm empty.

Bring hand back to position shown in Figure 28.

"So the Lord took one of Adam's ribs....."



Bring second finger of right hand down under ball. Finger should have second joint pressed firmly upward on ball.

Figure 29.



Figure 30 shows a side view away from audience.

SIDE VIEW



Press shell between thumb and first finger and press ball between first and second fingers. Using second joint of second finger as a pivot, raise ball upward with finger until it is in position shown in Figure 31. Shell remains between thumb and first finger and ball comes between first and second fingers.

This move is not difficult and you will have it mastered after practicing it a few times.

Thus you have mysteriously produced another ball.

"And made Eve."



Bring left hand up to right hand and take ball from between first and second fingers. As you do so, slip palmed ball from left hand into shell in right hand. This is an important move in Billiard Ball Manipulation and it is very easy to do.

Figure 32.

Separate two hands and show a ball in each.

"Adam and Eve."

FIG 32



FIG 33

Knock the two balls together to show that they are solid. Then replace ball from left hand between first and second fingers of right hand.

Figure 33.



FIG 34

"No doubt, you remember Adam's first Christmas Eve. It was then that Eve brought Adam....."

Bring third finger of right hand down under upper ball.

Figure 34.



FIG 35

Bring third finger upward and second finger downward, pivoting the ball to position between third and fourth fingers. First and second fingers are now together.

Figure 35.

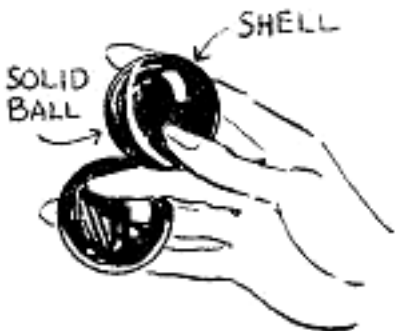


FIG 36

Turn hand so that audience can see empty palm.

Now bring ball side of shell and ball between first and second fingers. Grip ball well between these two fingers. Grip shell between thumb and first finger.

Figure 36.



FIG 37

Begin to turn hand so that back will be toward audience, and as you do so, get shell off ball and into position between thumb and first finger. You have mysteriously produced a third ball.

Figure 37.

"An apple."

NOTE:

The method I have given you for producing the third ball is effective for the balls are held close together and the appearance of the third shows up well. However, there is another method for producing the third ball which may fit some fingers better at first until the fingers limber up.

Here is the other method:

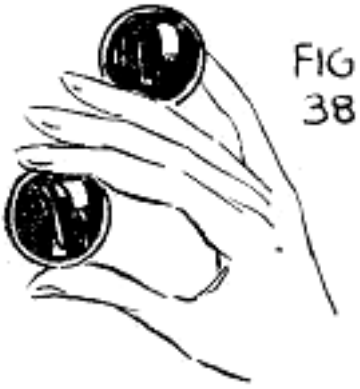


FIG
38

After second ball is produced and the two balls struck together, replace ball in right hand between third and fourth fingers instead of between first and second.

Figure 38.

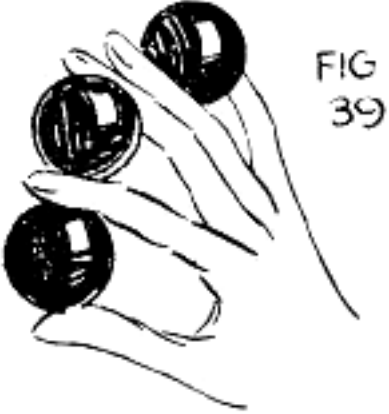


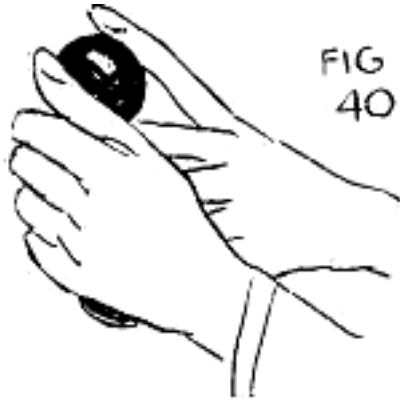
FIG
39

Turn hand and show palm empty. As you turn hand back to position again, get second finger under ball and lift it out of shell and into position between first and second fingers.

Figure 39. Try both methods and adopt the one that you can do the better.

(41-8)

"Now, Adam preferred ham and eggs for supper, but Eve insisted that an apple diet was far healthier as an apple a day keeps the doctor away."



Reach up with left hand and pretend to remove ball between first and second fingers. Under cover of left hand, slip ball into shell.

Figure 40.



Close left hand and carry it away as though it held the ball. Two balls are left in right hand and the illusion of removing a ball is perfect.

Figure 41.

Turn right hand over casually to show empty palm.

"So Adam ate the apple."



Bring left hand to mouth and pretend to place ball inside. Push tongue into cheek to make it bulge as if ball were really in mouth.

Figure 42.

Remove left hand and show it empty. Then push bulge of cheek in with left forefinger and pretend to swallow ball.

"Naturally, swallowing a big bite gave Adam indigestion and his trouble commenced. It was really too bad that chiropractic treatments had not been invented at that time for if Adam had been instructed to strike himself on the first lumbar vertebra....."

Strike small of your back with left hand. Then reach into left trousers' pocket and bring out the ball concealed there. Show it to audience.

"He could have taken it out here."

Place ball just produced between first and second fingers of right hand. As you do so, steal ball from shell and Finger Palm it in left hand.

"Oh, by the way, did I ever tell you about the beautiful daughter Adam and Eve had? Her name was Clementina."

With left forefinger point to three balls in right hand.

"There you are -- Adam and Eve and Clementina."

"One Sunday evening a young gentleman came to call on Clementina."



Produce ball in left hand suddenly at left
finger-tips.

Figure 43.

(41-9)



FIG
44

Place ball between third and fourth fingers of right hand.

Figure 44.

"Now mother leaves the room."

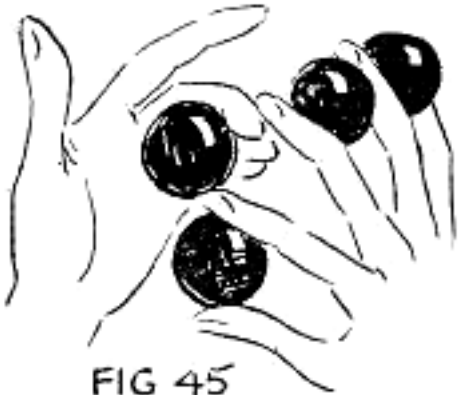


FIG 45

Reach up with left hand and pretend to take the ball from between first and second fingers of right hand. As left hand covers ball, Finger Palm it in left hand and then slip it into shell.

Figure 45.

Carry left hand away as if it held ball. Turn right hand over to show it empty, then back to position again.

Open left hand gracefully and show ball has vanished. Reach up with left hand and remove ball from between second and third fingers. Strike it against other two balls to show them solid. Place this ball between first and second fingers of right hand, and as you do so, steal ball from shell and Finger Palm in left hand. Bring left hand down to level of bottom of vest.

"But Adam - does Adam leave the room? Not much. He sits there, reading The Chicago American (or name local paper). Finally, Eve yells out, 'Oh, Adam, the beer is boiling over,' so Adam gets up....."

Vanish ball from between first and second fingers by bringing it down into shell. This is easy to do by merely reversing movement of the production from the shell. The lowering of the second finger pivots the ball into the shell. Now show empty palm of right hand.

"Leaves the room....."

Turn back of right hand to audience again.

"And goes down cellar."

With left hand, reach behind left knee and produce the ball already Palmed in that hand.

"But realizing it would never do to let Adam stay down cellar, Eye took Adam up the back stairway....."

Place ball up under right side of coat, apparently getting ball at armhole of coat, but really dropping ball into inside coat pocket.

"Into the attic and locked the door."

Remove hand from coat and let coat hang down.

"But Adam went down the front stairway....."

Produce ball out of shell between first and second fingers again.

"And into the parlor again. Then satisfied that he had outwitted mother,....."

Reach up with left hand and pretend to take ball from first and second fingers of right hand. Slip ball into shell. Bring left hand down as if carrying ball away. Show palm of right hand, then turn it back to position. Toss left hand into air and open it as you pretend to vanish ball into air.

"He retired upstairs."

Pick up top ball from right hand and strike the two balls together to show them solid. Replace ball between first and second fingers of right hand, and as you do so, steal ball out of shell.

"And thus Clementina and her beau were left alone. Now, it so happened that he tried to steal a kiss and she darted away."



Vanish ball in right hand by slipping it into shell. Show palm of hand, then turn it back to position. Quickly produce ball palmed in left hand from under right elbow.

Figure 46.

"And darted over here."

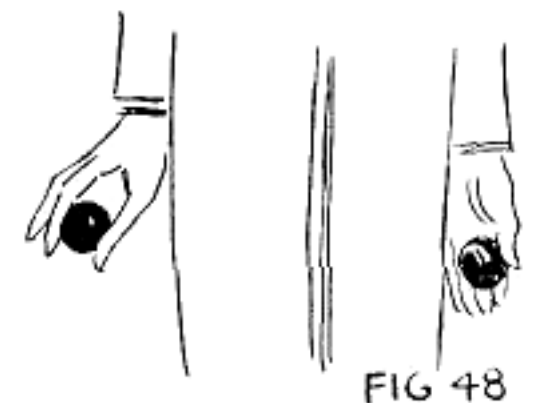
Place ball from left hand between first and second fingers of right and steal other ball from shell. Then place both hands down at knees. Keep back of left hand to audience as it conceals ball. Ball and shell in right hand are kept in



sight. Have legs a few inches apart so that it will not look as though a ball could be thrown in back of them.

Figure 47.

"Or an easy -- a knee-sy explanation -- would be to say that she played sort of a game of....."



With throwing motion of right hand, vanish ball into shell and produce ball from under left knee by turning left hand and exposing ball to audience.

Figure 48.

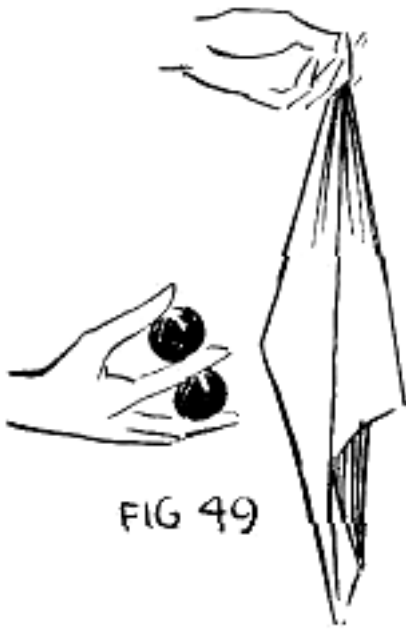
"Hide and seek."

Turn left side of body to audience again and place ball from left hand between first and second fingers of right, stealing ball from shell again with left hand.

"As it is getting rather late, Clementina's caller calls a taxicab."

Reach into left coat pocket, leave ball there, and bring out silk handkerchief. Hold silk by corner in left hand. Bring right hand down to position shown in Figure 49.

(41-11)





Be careful in moving right hand around not to expose edge of shell.

"So he kisses her goodnight."

Reach behind handkerchief with right hand to conceal balls.

Figure 50.

FIG 50



FIG 51

Let handkerchief drop on right hand.

Figure 51.



FIG 52

Pretend to pick up ball through the handkerchief with left hand. In reality, slip ball into shell and bring right hand away with one ball while left hand carries away only the silk.

Figure 52.

Grasp a corner of handkerchief between first and second fingers of right hand and snap silk from left hand, showing that ball has vanished. Place silk in left hand again as in Figure 49. Suddenly reach behind silk with right hand. Bring ball out of shell into first and second finger position and bring out hand, showing two balls. This should be done quickly.

"He started to go but came back to say good night all over again."

Place right hand behind handkerchief and vanish ball into shell again. This time shake silk with left hand and show one ball in right hand. Show palm and backs of hands.

Bring right hand over to silk in left, and under cover of handkerchief, remove shell from ball and place it in left coat pocket with handkerchief. Get ball on right fist as in Figure 9.

"Thus leaving the beautiful Clementina....."

Cover ball with left hand, pretend to remove it, dropping in into right hand. See Figures 11, 12, 13. Looking at closed left hand, say:

"To hie herself upstairs."

Toss left hand into air and open it, showing that ball has vanished.

"And dream pleasant dreams. While Adam -- comes down....."

Reach suddenly into the air with right hand and produce

the ball at finger-tips.

"To put out the cat."

(41-12)

NOTE:

The moves required to present the above routine are not difficult, but you must practice them to do them gracefully and with good showmanship. Study your ANGLES OF VISIBILITY carefully so as not to expose shell at wrong angle. Practice bringing ball in and out of shell until you can do it easily. Practice until you can put art into your work. Do not forget to look at your audience often.

* * * * *

RAINBOW BILLIARD BALLS

This effect is performed with balls of various colors. It is taught to you in pantomime style and is best presented with music. There is no reason, however, why this effect cannot be "Pattered" and used without music, or pantomimed without music.

The effect of the different-colored balls is very pretty and will make a good number for your programs. Before you attempt this experiment, however, be sure that you have mastered the moves in the preceding routine.

EFFECT:

Four balls mysteriously appear between the fingers of the Magician's right hand, one at a time. These balls apparently change color at will. At the finish, a red, a white, a green, and a yellow ball are held between the fingers and are then dropped onto a plate one at a time to prove them solid.

PARAPHERNALIA:

1 -- A set of Rainbow Billiard Balls, which consists of:

1 white ball - 1 white shell

1 yellow ball

1 green ball

1 red ball

These balls are 1 3/4 inches in diameter.

We can supply you with a beautiful set of Rainbow Billiard Balls at a reasonable price.

MODUS OPERANDI:

To Prepare:

Place WHITE SHELL over YELLOW BALL in rear right trousers' pocket. Place GREEN BALL in left coat pocket and RED BALL up under left side of vest, about two inches up from bottom edge. (Here you utilize the principle of VESTING again, taught you in the preceding lesson.) Place WHITE BALL in right coat pocket.

If this experiment is to be performed after "Adam and Eve," you can arrange the balls a little differently so as not to interfere with the first effect you perform. The white shell and yellow ball can be in the right coat pocket instead of the trousers' pocket or in the right vest pocket. In arranging a program, the placing of the balls in preparation for this effect will have to be done in accordance with your requirements. You will have no difficulty, however, in varying your arrangements.

To Perform:

Got WHITE ball into palm of right hand. Do the Change Over Palm and get ball into left palm. See Figures 6 and 7, using opposite hands. Now produce ball on closed left fist. See Figures 8, 9, and 10.

Throw ball into air twice, then pretend to throw it a third time but keep it palmed in left hand. See Figures 15 and 16.

Produce ball from right elbow or by pretending to blow it from nose, allowing it to ball down into right hand. Then turn left side of body to audience. Toss ball to left hand, back to right, then to left again. Pretend to toss it once more to right hand but keep it Palmed in left. See Figure 22. Then open right hand and show that ball has vanished.

Look at audience a moment, then raise forefinger of right hand to head as though you had made a discovery. Reach into back pocket with right hand and take WHITE shell with YELLOW ball from it. Hold it between thumb and first finger of right hand so that only shell shows to audience. Apparently you have produced the white ball which you vanished a moment ago.

Suddenly produce the yellow ball between first and second fingers of right hand. See Figures 28, 29, 30, 31.

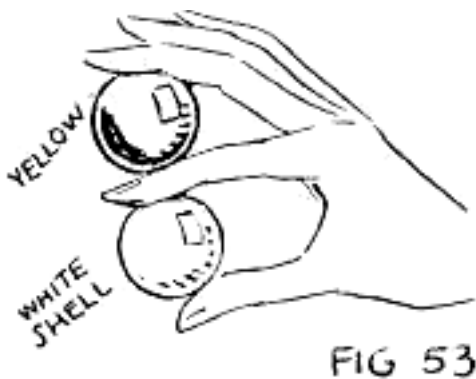


Figure 53 shows mysterious appearance of yellow ball between fingers.

To show ball and shell as two solid balls --



Hold balls as in Figure 53. Bring third finger under yellow ball.

Figure 54.



FIG 55

Figure 55 shows a side view of this position, away from audience.

Grip yellow ball between second and third fingers and bring it downward between these two fingers. Bring shell upward between thumb and first finger until it can be gripped

(41-14)



FIG 56

between back of second finger and first finger. You may keep thumb on shell or remove it, as you like. Be sure to keep back of shell away from audience. As you make this movement, wave your hand a little.

Figure 56.

You have now shown back and front of right hand and have apparently shown all sides of the balls.

Bring shell and ball back to position shown in Figure 54, and finally to that in Figure 53.



FIG 57

THUMB TWIST METHOD:

Here is another method for apparently showing ball and shell on all sides to convince audience that you hold two solid balls. This is a very handy method.

Hold ball and shell as in Figure 57.



FIG 58

Bend forefinger, rolling shell back to thumb joint.

Figure 58.



FIG 59

Bend thumb inward, turning shell with it so that front of shell faces outward as you expose palm of hand to audience. Thus you have shown back and palm of right hand and audience believes they have seen all sides of the balls.

Figure 59.

Right hand may be brought over in front of body and turned outward to expose palm.

This move is not difficult, once you get the knack and can determine the exact position of shell on thumb joint at which you can turn it easily. In an emergency, third finger can be pressed against edge of shell to turn it.

Now bring shell back to position by reversing movements performed above.

You now have the white shell and yellow ball in right hand and the white ball palmed in left hand.

Bring left hand up to right and remove yellow ball, at the same time, slipping white ball into shell. See Figure 32.

Strike balls together to prove them solid. Then place yellow ball between third and fourth fingers of right hand.



FIG
60

Show palm of right hand freely now, for white ball is in white shell. Then as you turn hand to show back again, bring white ball out of shell between first and second fingers.

Figure 60.

(41-15)

Expose right palm again and show balls solid by Thumb Twist Method.

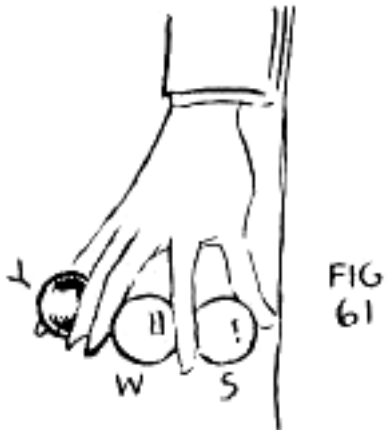
With tossing motion of right hand, vanish white ball by dropping it into shell again. Show both sides of hand.

Reach into left coat pocket with left hand and Palm out the GREEN ball.

"Here?"

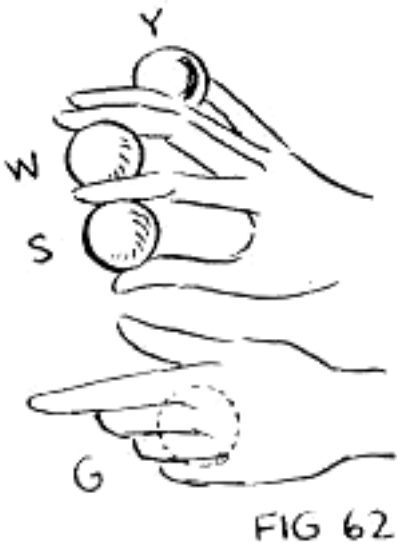
Shake your head and remove hand as though there was nothing in it.

"No -- here."



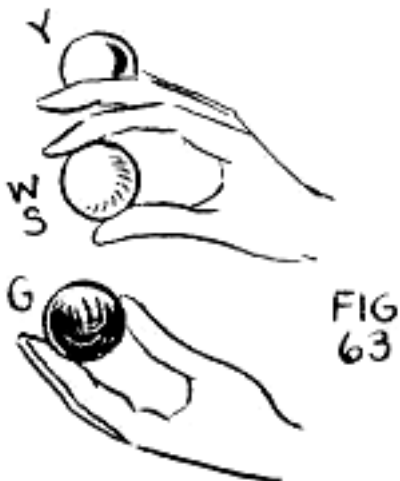
Produce white ball from behind right knee in this manner: Place right hand back of knee. Lift white ball out of shell into first and second finger position, and bring hand out showing appearance of white ball. Take white ball from finger of right hand placing green ball in shell. Strike balls to prove solid and to show left hand empty. Replace white ball in right fingers and Palm out green ball into left hand.

Figure 61.



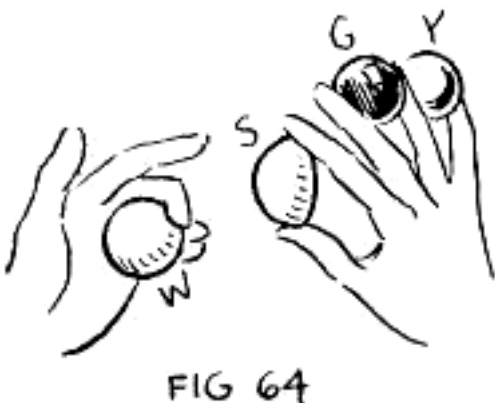
Now you perform the "THROW DOWN" COLOR CHANGE:

Hold hands to your right in position shown in Figure 62. This is view of hands as audience sees them.



Raise right hand about twelve inches above left. Then with throwing motion downward, slip white ball into white shell, and just as it is supposed to drop into left hand, expose green ball in left hand. The effect is that you threw the white ball down into left hand and it changed to green as it fell.

Figure 63.



Place green ball between second and third fingers of right hand and steal white ball from shell with left hand. See Figure 40.

Figure 64 shows position of balls at this stage. This view is away from the audience.

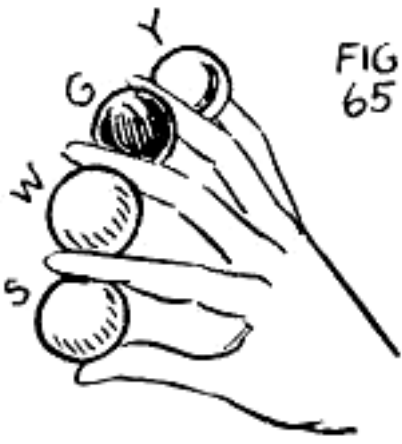


FIG
65

Reach into air with left hand and produce white ball on left fist.

Look at audience in quizzical way after this production, just as though you didn't know how it happened yourself. Then place white ball between first and second fingers of right hand.

Figure 65.

(41-16)

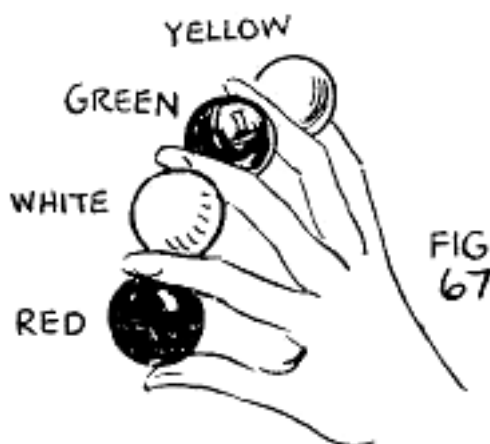
Look at the display of the four balls to MISDIRECT attention as you bring left hand against left side of vest. Press base of thumb against top of RED ball, Vested there. Move right hand downward and upward in sweeping motion, and at the same time, push left thumb against Vested ball, forcing it down into left palm where it is Finger Palmed, or get ball by lifting edge of vest with thumb as you did in your last lesson for getting flag.



Bring left hand up to right and place red ball in white shell.

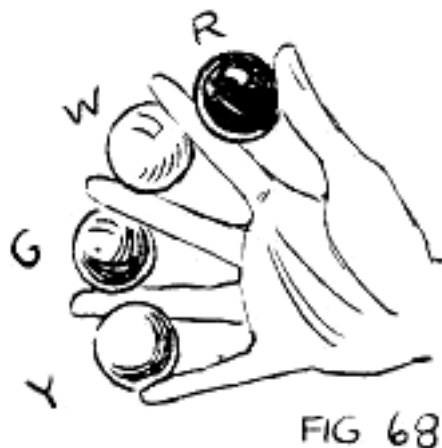
Figure 66.

Remove red ball and white shell with left hand, being careful not to expose red ball to audience. Show both sides of right hand. Replace shell and ball between thumb and first finger of right hand and show both sides of left hand.



Now bring left hand up to right again and Finger Palm white shell away from red ball. Red ball is now exposed and the effect is that you touched the white ball with your left hand and caused it to change to red.

Figure 67.



Turn right hand over to show that palm is empty and that balls are all solid.

Figure 68.

Drop balls on to dish on table, one at a time. Keep back of hand toward audience and drop red ball first, then white one, then green one, and finally yellow one. Turn palm of right hand with fingers wide apart toward audience to show it empty. Dispose of shell by getting some article from pocket for next trick or in any manner you find suitable for the occasion, such as casually placing hand in pocket for a moment.

SUGGESTION:

If inconvenient for you to carry red ball under vest, have it in left trousers' pocket. Turn right side toward audience as you hold right hand high up to show four balls. Reach into pocket with left hand and Palm out red ball, then turn left side to audience again.

* * * * *

A MYSTERIOUS BALL TRANSPOSITION

There have been many descriptions written for this effect in which a red ball is wrapped in a piece of paper or handkerchief and a black ball is wrapped in another paper or handkerchief, and upon command the balls change places. I have seldom seen it performed, however. I have myself tried out several methods, but the effect proved to be somewhat lifeless and so I discarded them. I finally worked out this

method which is clean-cut, snappy, and gives a chance for applause at the end. The suspicious moves are eliminated -- the effect is sped up and has entertainment value.

EFFECT:

Performer freely shows a red and a green billiard ball, a red and a green handkerchief, and two glass tumblers. Performer wraps the green ball in the green handkerchief and places it in one of the glasses. The red ball is wrapped in the red handkerchief and placed in the other glass. Magician suddenly whisks the green handkerchief from the glass, showing the red ball whirling in the glass and then whisks the red handkerchief from the other glass, showing the green ball there.

PARAPHERNALIA:

1 -- 1 green billiard ball

1 red billiard ball

1 red shell

2 -- One green silk handkerchief

One red silk handkerchief

Silks must be heavy enough so that audience cannot see color of ball through them.

3 -- Two glass tumblers

4 -- A table -- a card table is suitable for many occasions

MODUS OPERANDI:

To Perform:

Show the two glasses, the two silks, and two balls freely. Shell is on red ball.

Place glasses on table about 18 inches apart. Place silks on table within easy reach.

Place red ball with shell between thumb and first finger of right hand, shell facing audience. Place green ball between first and second fingers. Show hands freely for audience must be convinced that you use only two balls. Then pick up green silk and place it over left hand.

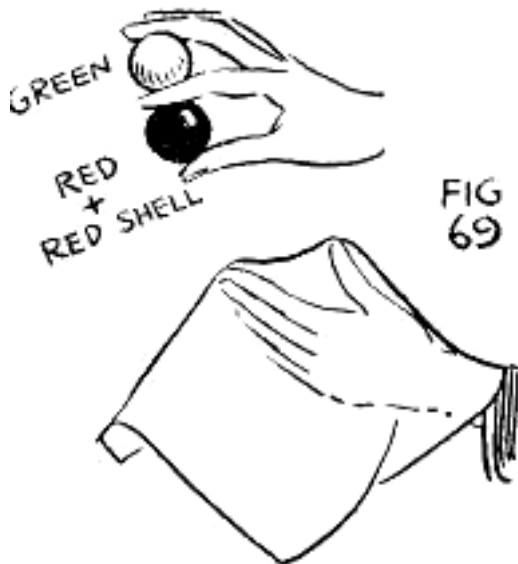


Figure 69.



FIG 70

Bring left hand over to right and pretend to take green ball in center of handkerchief. In reality, slip red ball out of shell into handkerchief and drop green ball into red shell.

Figure 70.

(41-18)



Bring left hand away and drop silk completely over ball. Grasp silk under ball to show ball wrapped in center of silk. Show red ball remaining in right hand.

Figure 71.

"Green."

FIG 71



FIG 72

Place silk with ball into glass tumbler at right. Form of ball can be seen through glass. Part of silk hangs out of glass so that it can be jerked away when time comes.

Figure 72.

Pick up red silk and place over left hand. Place red shell and green ball into center of silk, turning them so that shell is on bottom and ball can be grasped through the silk in left hand.

"Red."

As you say this, turn right side to audience. Remove right hand from silk with shell Finger Palmed. Grasp red silk as you did the green one before and place it with ball in second tumbler.

Point to right-hand glass.

"Green."

Point to left-hand glass.

"Red."



FIG 73

With right hand, grasp corner of green silk and jerk it suddenly from glass, causing red ball to whirl in the glass.

Figure 73.

"NO: RED!"

Grasp red silk with left hand and jerk it suddenly from glass to show green ball whirling there.

"GREEN!"

Dispose of shell in the silks. I have often disposed of shell by putting it in my right coat pocket at the moment I jerk first silk from the glass - in this case, using left hand for jerking away first silk.

* * * * *

CUPS AND BALLS

Who is there in Magic who has not heard of the famous cups and balls? It is the mysterious effect in which the balls vanish, appear, and jump about under three cups. This is one of the oldest tricks in Magic. It has many routines and has

also been the foundation for many variations from the disappearing and producing of balls under cups to the three shell game of the circus, paper wads through a hat, etc. In days gone by, this effect was a feature trick on programs of many Magicians and it then involved much artistic sleight of hand.

In this lesson I give you a modernized version of Cups and Balls with simplified moves which make it easy to perform and yet effective. You will find this effect good for close work. It is fine for parlor or dining room entertainment as well as club work.

EFFECT:

Performer shows three paper coffee cups and three balls made of sponge rubber. A ball placed on top of one cup and covered with another cup is suddenly found under the first cup. This is repeated and the second ball also finds its way under first cup. The third ball is picked up and disappears from the hands, only to appear again under the cup with the other two. The balls continue to appear and disappear until finally the cups are lifted to show a potato under one, an onion under the second, and a lemon under the third.

PARAPHERNALIA:

1 -- Three paper coffee cups, such as are used for picnics. These cups are usually 3 3/4 inches high and 2 3/4 inches in diameter across the top. They are straight cups and have the bottom raised about 5/16 of an inch. These cups can be purchased at almost any department store or other store where picnic supplies are sold.

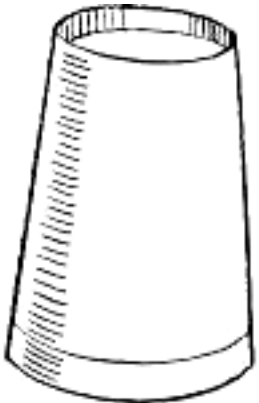


FIG
74

Figure 74.



FIG
75

2 -- Get a red rubber bath sponge at a drug store or department store. With a pair of scissors cut out four rubber balls, about seven-eighths of an inch to one inch in diameter.

Figure 75.

3 -- A potato, an onion, and a lemon or lime.

SECRET AND PATTERN:

To Prepare:

Place one of the rubber balls on top of inverted cup.

Figure 76.



A
FIG
76

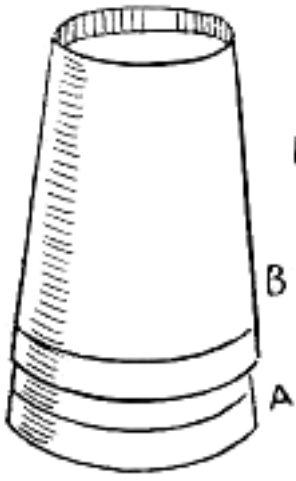


FIG
77

On first cup, place another one, also inverted.

Figure 77.

(41-20)

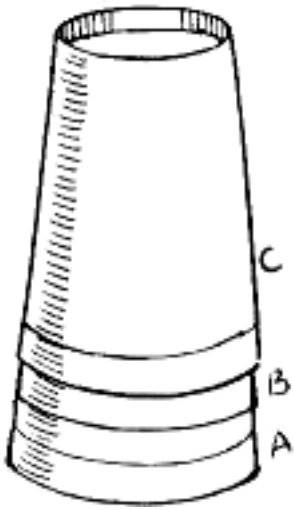


FIG
78

Place third cup on top of other two.

Figure 78.

Place the small potato, onion, and lemon (or lime) in your right coat pocket.

To Perform:

NOTE:

I shall give you the routine without usual patter as the patter for this effect is really a matter of -- "there it goes," and "here you are." You can easily talk your way through the experiment.

Place three rubber balls on the table. Show the three stacked cups.

Now hold cups up in right hand as shown in Figure 79. Remove first cup and place on table upside down. Do this rather speedily, and keep top of second cup away from audience so that they cannot see rubber ball inside. Then remove second cup.

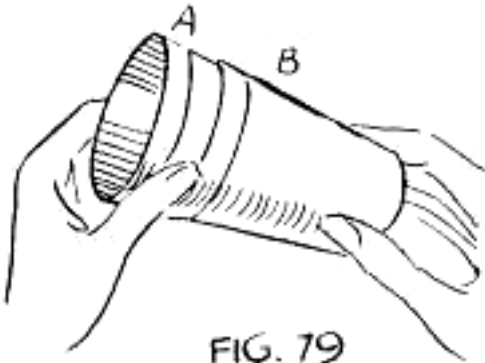


FIG. 79

Take second cup in left hand, holding it at just enough slant to keep rubber ball from falling out.

Figure 80.

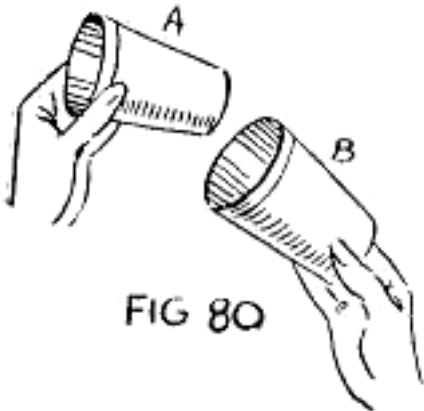


FIG 80

Place second cup down on table, speedily and snappily also, so that rubber ball comes under cup without being seen.

Figure 81.

Place third cup down on table also. Your movements, if done properly, will arouse no suspicion for you seem to handle the cups in a manner which would not seem possible if the cups were not empty.

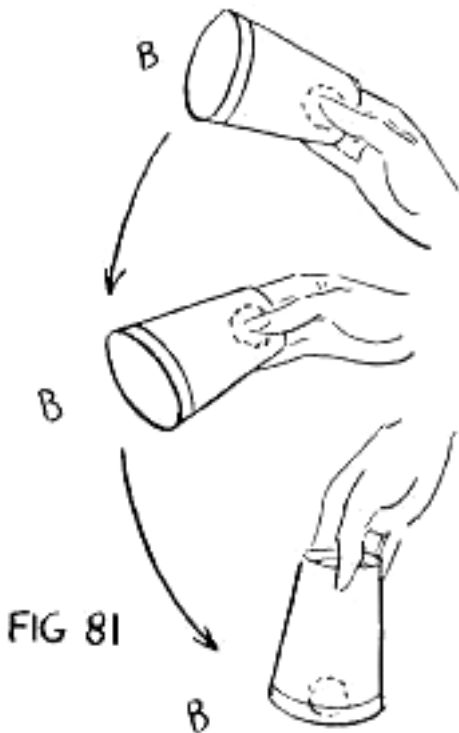


FIG 81

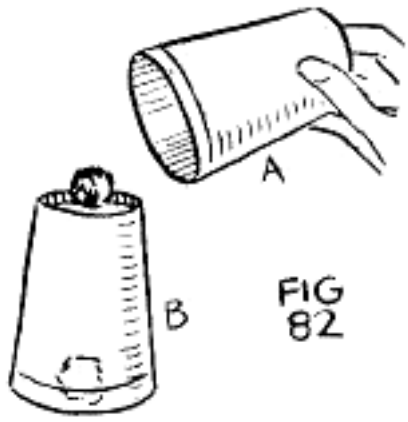


FIG
82

Place a rubber ball on cup B and cover it with cup A. You now have a ball under the bottom cup and one between the two cups.

Figures 82 and 83.

(41-21)

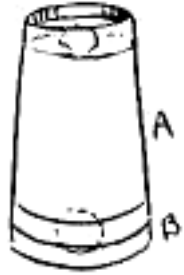
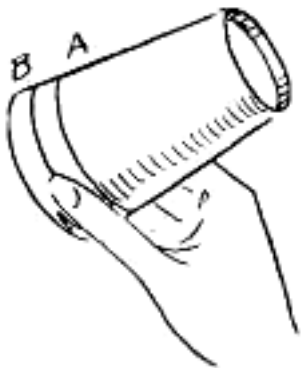


FIG
83

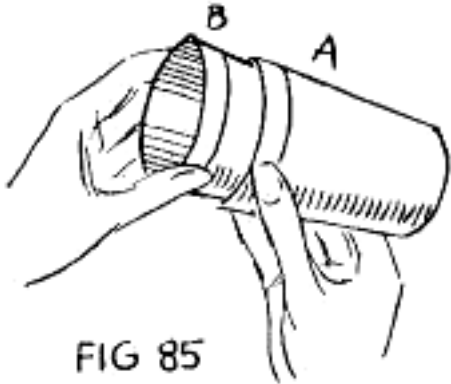


Lift up both cups and show that ball has apparently passed through cup B.

Figure 84.



FIG 84

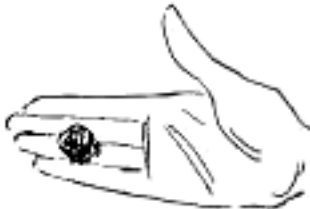


Remove cup B from cup A. Then place cup A down on table over first rubber ball. You now have two rubber balls under cup A, but audience knows of only one ball.

Figure 85.

Place another ball on cup A and cover it with cup B. Lift up both cups and show that this ball has also gone through lower cup as you now have two balls under cup.

Remove cup A from cup B and place B down over two balls on table. You now have three balls under B. Audience is aware of only two.

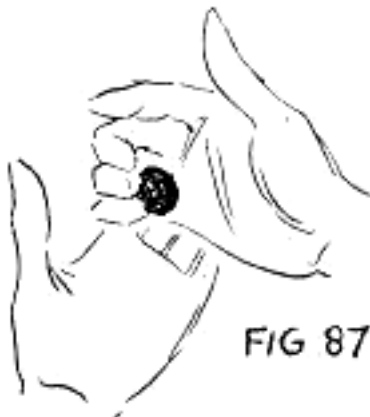


Pick up remaining ball from table with right hand. Hold it on fingers, palm upward. Bring left hand up to right.

Figure 86.

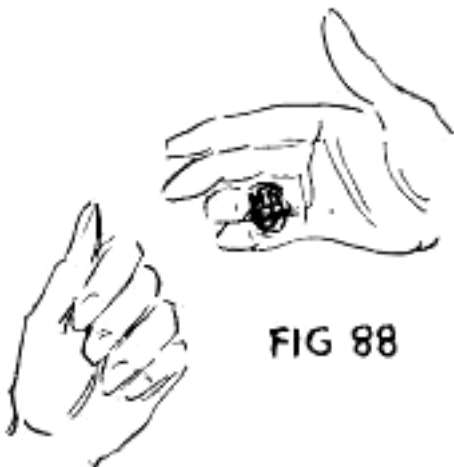


FIG 86



Pretend to place ball in left hand, but really Finger Palm it in right.

Figure 87.



Close left and carry it away as though it held ball.

Figure 88 is a view toward yourself.

FIG 88

Pretend to throw ball through top of cup B with left hand and open hand to show it empty. Lift up cup B and show the three balls under cup.

Figure 89.



FIG
89



TWO HELD
TOGETHER
AS ONE

Pick up one of the three balls with right hand and place it against the one Finger Palmed. Press the two balls tightly together and take them as one between thumb and first finger of left hand.

Figure 90.



FIG 90

Squeeze rubber enough to make the double ball the same size as the others and it will look like one ball. As you place double ball in left hand, say, "One."

Pick up another ball and place it between first and second fingers of left hand. Say, "Two."

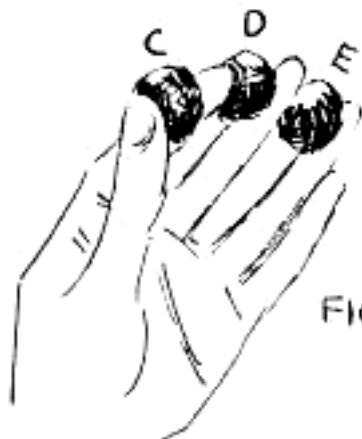


FIG 91

Then take remaining ball from table and place it between second and third fingers of left hand, saying, "Three."

Figure 91 shows arrangement of balls in left fingers.

Now take ball E and place it down on table. A few inches to the left of it place ball D. Cover each with a cup.

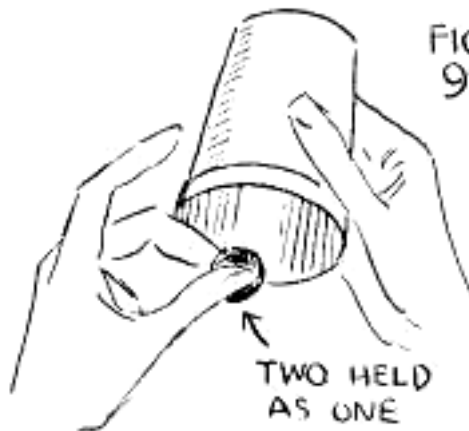


FIG 92

Then take third cup. Keep side toward audience tilted downward so that double ball will not be visible as you place it down on table under this cup.

Figure 92 in a view away from audience.

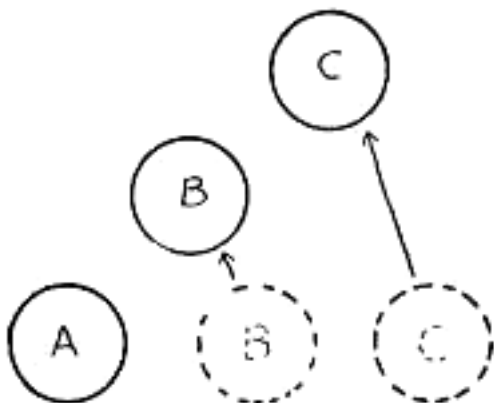


FIG 93

The three cups are in a straight line on table. Take hold of cups B and C with left and right hands and push them back a little way in diagonal line as shown in Figure 93.



FIG 94

As you do this, do not lift cup B from table, but raise rear edge of cup C just enough to slide rubber ball out so that you can Finger Palm it in third and fourth fingers of right hand. You move cup, and ball remaining on table is easily gotten into fingers.

Figure 94.

Do this quickly and then slide cup flat on table the rest of the way. To all appearances, you have merely moved the cups.

Now say, "We have a ball under each cup," and proceed to show them.



FIG 95

Pick up cup B with left hand and show ball still under it. Transfer cup to right hand, getting top of it well into palm so that Finger Palmed ball can be dropped into it.

Figure 95.



FIG 96

Figure 96 is a view toward yourself, showing ball inside cup. Audience's attention is MISDIRECTED to ball on table and they are not aware of your movements with right hand.

Place cup B down over ball again. You now have two balls under cup B.

Lift cup C, showing that ball has vanished. Lift cup A to show that it has passed over there, as you have two balls under that cup. Pick up one of the balls, pretend to place it in left hand (Finger Palming it in right), and then pretend to

(41-23)

drop ball from left hand through top of cup B. Lift cup B, showing two balls under it.

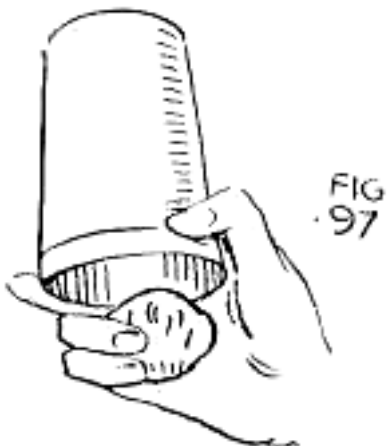
Pick up all the balls, getting one of them against ball Finger Palmed in right hand. Hold these two as one between thumb and forefinger of right hand. See Figure 90. Place other two balls between fingers as in Figure 91.

Now place ball E at left side of table and cover with cup. Place D a few inches away and cover with cup. In getting C under third cup, place just one ball under cup and suddenly reach into right coat pocket with right hand. Leave fourth ball in pocket and quickly palm out the potato. Remove hand from pocket with potato Finger Palmed.

The sudden movement to pocket will cause spectators to suspect that you did not place third ball under cup. After a bit of byplay, raise cup C with left hand and show ball under it.

Transfer cup to right hand so that potato comes directly under mouth of cup.

Figure 97.



Lift rubber ball from table with left hand. At the same time, replace cup on table with right hand.

Figure 98.



As you do this, tilt rear edge of cup upward and get potato under cup. Place cup squarely down on table and place hands flat on table also. This is done to prove that you have nothing concealed in hands.

Figure 99.

Say, "No, I would not put anything in my pocket without telling you. However, now I shall place this ball in my pocket."

Take rubber ball from left hand with right and place it in right coat pocket, Palming out the onion at the same time. Bring hand out of pocket. Pick up middle cup with left hand, showing ball under it. Place cup in right hand, ready to load onion into it. Pick up ball with left hand and place cup down on table, secretly placing onion under it as taught to you above.

Say, "I shall also place this ball in my pocket."

Leave ball in right coat pocket, bringing out lemon, Finger Palmed. Lift cup A with left hand, showing ball. Place cup in right hand, ready to load lemon into it. Pick up rubber ball from table with left hand and place cup down on table with lemon under it.

Then remark, "And finally, the third and last ball into my pocket."

Place ball in pocket.

Say, "Or, better yet, I will take the ball....."

Remove hand from pocket with ball and show it. Pretend to place it in left hand and then apparently throw it through cup A with left hand. Ball is Finger Palmed in right hand.

"And throw it through the cup. Then take another....."

Reach into right pocket again and bring out same ball. Vanish it in left hand and pretend to throw it through middle cup. Reach into pocket a third time and bring out same ball.

"And another."

Vanish ball in left hand and pretend to throw it through cup C.

Now pick up left-hand cup A and place it aside, showing the potato under it. Lift the middle cup B and show the onion.



Say, "And the answer" -- and lift third cup C and show the lemon.

Figure 100.

The production of the potato, the onion, and the lemon comes as a great surprise and makes a good finish for this effect.

FIG 100

Harlan Tarbell

TARBELL SYSTEM, INCORPORATED, Chicago.

LESSON 42

Interesting effects by Bert Douglas, Canadian Magician. Bert has certainly done himself proud with these effects and this lesson alone is worth more than the price of the whole course.

Also included in this lesson is "Popping corn in a borrowed hat," and my "'Clean Cut' color changing handkerchief."

LESSON 42

This lesson is filled with novelty ideas in Magic. Of especial value is their inexpensiveness to prepare. The material is excellent for the beginner and will be readily welcomed by the professional as well.

This lesson contains my own effect, the "Clean Cut" Color Changing Handkerchief—Arthur Pope's "Vice Versa" Color Changing Handkerchiefs—Cardini's experiment on changing a silk to a billiard ball—Three original novelties by Bert Douglas, eminent Canadian Magician—and the famous Popping Corn in a Hat.

We owe our heartfelt thanks to Bert Douglas for releasing these three master effects. This type of Magic is very difficult to obtain. The fact that some of the world's greatest Magicians are releasing effects for this course proves the high regard in which they hold it. Outside of this course, you could probably never obtain this information even if you spent thousands of dollars.

* * * * *

THE "CLEAN CUT" COLOR CHANGING HANDKERCHIEF

Years ago I brought out my self-contained color changing handkerchief, which I have already described to you in a previous lesson. Some time ago I brought out another bit of apparatus for changing the color of an unprepared handkerchief. This method is clean cut and eliminates all moves of a bungle-some nature.

I have performed my "Clean Cut" Color Change for years and yet, strange to say, I have never seen it duplicated or had anyone give me the correct explanation for working the effect. Color Changing methods have come and gone, but I have never found one which works with unprepared silks as this one does. I have kept my "Clean Cut" method secret until now, but I am teaching it to you in this lesson so that you may add it to your knowledge of Magic. It is a combination of age-old principles, presented in a modernized way.

EFFECT:

Performer shows an unprepared red silk handkerchief. He tucks the silk into his empty left hand, then suddenly opens his hand and shows that silk has changed to green. Hands are shown freely and audience is permitted to examine silk if desired.

PARAPHERNALIA:

1 -- One red handkerchief.

One green handkerchief.

--Each about 12 to 13 inches square.

Two other colors may be used instead, if you wish.

The handkerchiefs furnished with this course are ideal for this experiment.

2 -- The "Clean Cut" Color Changing Apparatus.

This consists of a small brass tube, one inch in diameter and one inch and a quarter long. The bottom and top edges are turned in a little to prevent the sliding wooden partition in the tube from falling out. The sliding partition is made of wood so that it will be noiseless in operation. The bottom of it is covered with felt so that when a silk is placed under it there will be no danger of silk catching. At one point at top of tube there are two holes, through which a piece of catgut or thread is looped. This loop is of such length that when it is placed over thumb, the tube will hang in center of palm of hand. The outside of tube is painted flesh color or black.

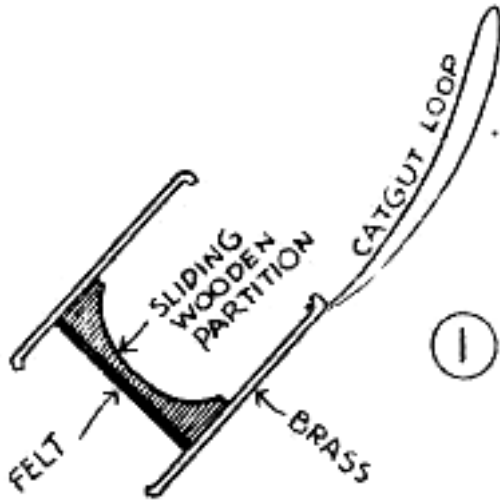


Figure 1 shows a cross-section of tube to explain its construction.

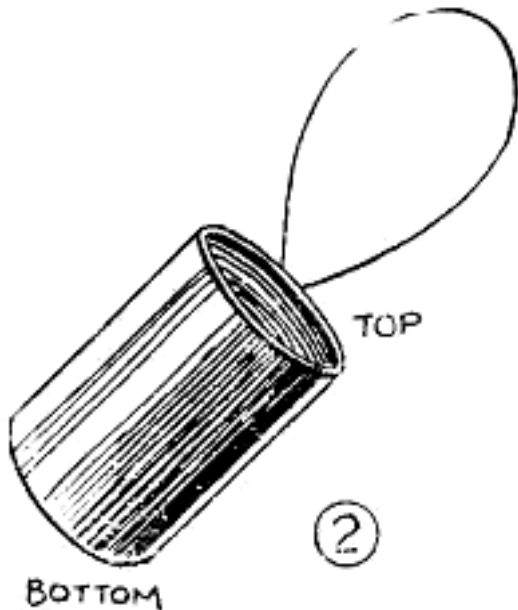


Figure 2 shows how the tube looks from the outside.

The tube is arranged so that if a silk is placed in the bottom end, it pushes the wooden partition to the top. Then if a silk is forced into the top end, it pushes the partition downward, causing the bottom silk to come out.

This device is built on the small dye tube and the loop principles. It enables the performer to do some clever things which puzzle even the keenest observer.

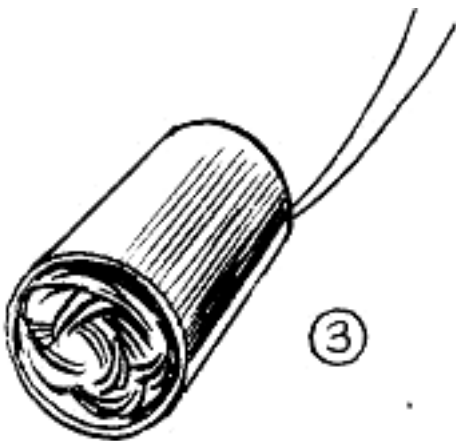
We can furnish you with this apparatus, beautifully made and complete with a red and green silk handkerchief at a very reasonable price. The apparatus alone without the silks is somewhat less.

SECRET AND PATTERN:

To Prepare:

Place the green silk in the bottom of the tube, first pushing in the center of the silk and then the four corners. Arrange silk so that it fits in snugly without any ends sticking out.

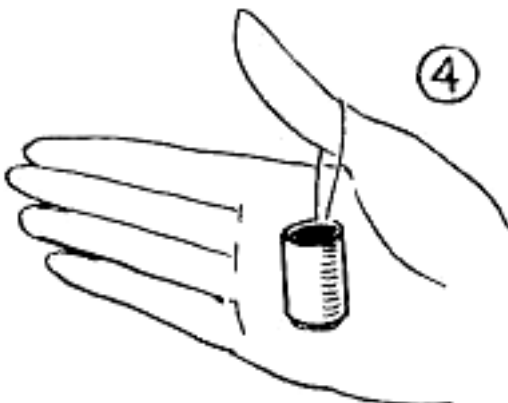
Figure 3.



Adjust the loop over thumb so that tube hangs down in center of palm.

Figure 4.

(Should you need to replace the catgut, just get some surgeon's catgut, No. 0. In emergency a fine violin string will do, or a piece of fine white thread.)

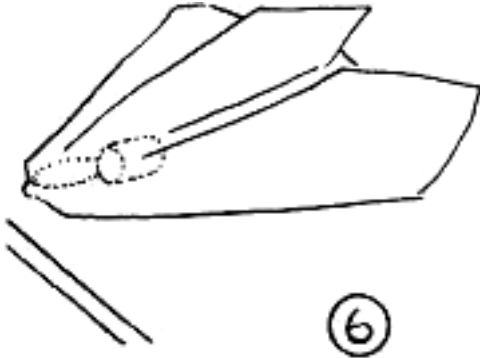




When you handle the apparatus, do so in a NATURAL manner. You can curl third and fourth fingers over tube or let it just swing suspended from thumb, keeping thumb spread apart from fingers.

Figure 5.

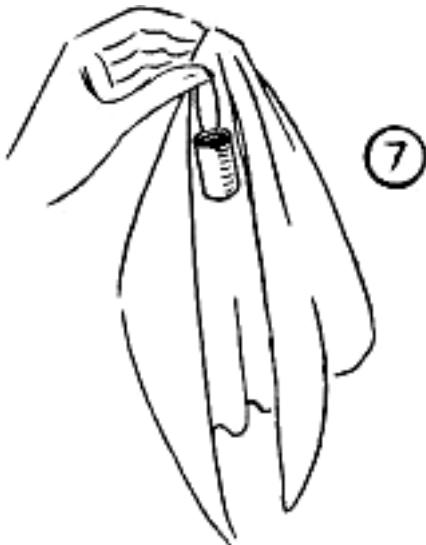
There are various ways in which you can get hold of apparatus. One way is to have it in your pocket, together with the second silk, and to get it as you reach into pocket for silk.



Another way is to have handkerchief lying on table with tube concealed under it. Loop can be grasped as you pick up handkerchief.

Figure 6.

Tube may be hanging on a small nail or brad at back of table or at back of a chair. Thus if you have been performing with a silk, you may place it in your pocket for a moment and then bring it out again for the next experiment, getting the tube—or you may lay silk on table or over back of chair to secure tube. As apparatus is small, it is very easy to conceal and easy to get hold of without being detected.



To Perform:

Let us suppose that tube is lying under red handkerchief on table. Pick up center of handkerchief with left hand, grasping loop on tube at same time. Keep tube concealed behind handkerchief.

Figure 7.



Transfer silk to right hand, slipping right thumb through loop of tube as you take silk.

Figure 8.

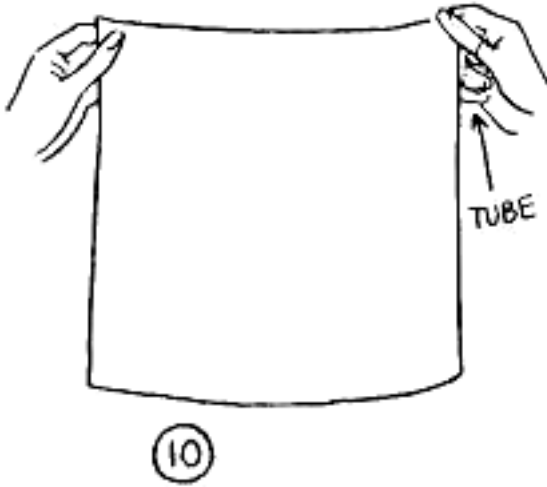
When silk is held in this position with palm of hand to audience, the audience is convinced that you hold nothing in right hand but the silk. Left hand is also shown empty. You do not call attention verbally to empty hands for the audience believe their own eyes rather than what you tell them. A clean cut move is worth more than many words to demonstrate a point.



"This is a piece of Oriental silk and might be mistaken for a silk handkerchief."

Allow right hand to come down in front of handkerchief from position shown in Figure 8 to that shown in Figure 9.

This move swings tube over from behind silk into palm of hand, where it can be held easily as shown in Figure 5.



Open handkerchief out and hold it at upper corners between both hands.

Figure 10.

(42-3)

"This is in reality a piece of goods for a lady's dress. You can readily see what a great change in fashion there has been since the year 1890."

Release hold on corner of handkerchief with right hand, allowing silk to hang suspended from left hand. Then grasp center of silk with right hand.

Figure 11.

Remove left hand from handkerchief and hold silk in right hand as in Figure 9. Raise fingers and get tube behind silk as in Figure 8.

"I assure you it would take but a few moments to make a nice red dress, rich in Oriental splendor, put of this material. You could then carry the dress in your purse."

Bring left hand up behind silk and close fingers around tube.

Figure 12.

Start pushing center of silk into tube. Audience is not aware of tube, of course, and believes you are merely pushing into left hand. As you force silk into tube, wooden partition is pushed downward, forcing out the green silk at other end.

Figure 13.

"How handy to tuck a dress away into such small quarters. That is the advantage of having a dress of this Oriental silk."

Tuck all of the silk into the tube. Right thumb may be removed from loop for a moment to show right hand empty and then replaced. Be sure to keep green silk well concealed in left hand after it is out of tube.

Figure 14.

With fingers close together, bring right hand down in front of left. Raise right thumb, drawing tube out of left hand.

Figure 15.



Move closed left hand with back to audience out toward the left. Hold right hand naturally with fingers and thumb fairly wide apart to convince audience that nothing is concealed in it.



16

Figure 16.

Keep your eyes on left hand. Turn hand over so that front of it faces audience. Then pretend to overhear a remark from some spectator.

"Pardon me, you say, Madam, that you never wear a red dress."

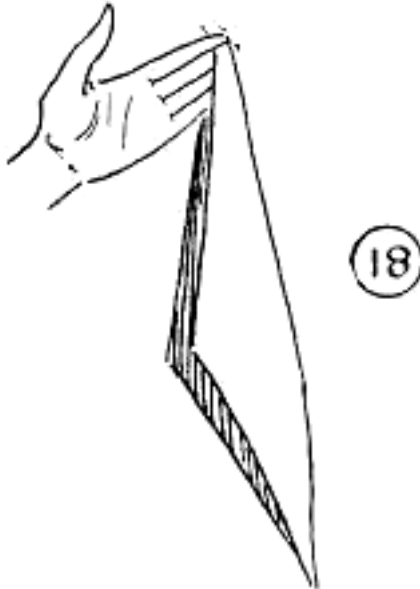
(42-4)



Open left hand, allowing silk to spread itself.

Figure 17.

"Then, how about a green one?"



Allow silk to fall, grasping it at one corner in left hand.

Figure 18.

Grasp center of silk with right hand as in Figure 11. Then hold it in right hand as in Figure 9, and finally as in Figure 8.

"That's the advantage of Oriental silk. It changes color to fit your moods."

You may now place apparatus aside with the silk. Or you may remove silk with left hand, holding apparatus as in Figure 5. Dispose of apparatus in pocket by reaching for some other article you need, such as a yellow silk to perform the next effect.

* * * * *

THE "VICE VERSA" COLOR CHANGING HANDKERCHIEFS

This is one of Arthur M. Pope's impromptu novelties, which can be performed on the spur of the moment.

EFFECT:

Performer shows two silk handkerchiefs, one green and one yellow. He says that he will cause the green silk to turn yellow and the yellow one to turn green. Pulling the silks through his left hand with his right, the changes of color take place.

PARAPHERNALIA:

1 -- A green silk handkerchief and a yellow silk handkerchief. You may use any other colors which you desire.

SECRET AND PATTEN:

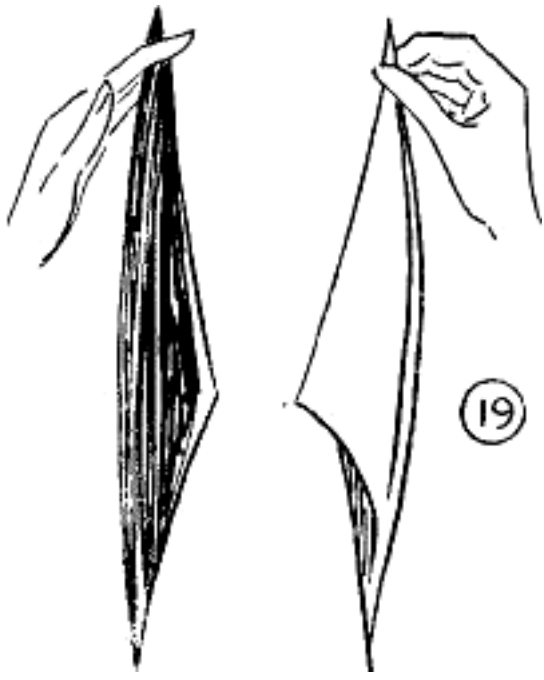
To Prepare:

You need no preliminary preparation as effect is entirely impromptu.

To Perform:

Hold green silk between first and second fingers of left hand. Hold yellow silk between thumb and first finger of right hand.

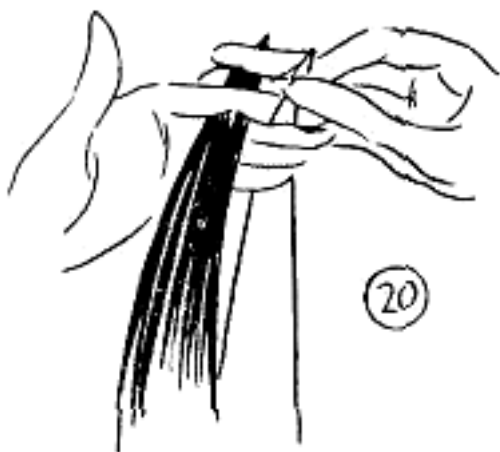
Figure 19.



"There were two ladies, each of whom bought herself a new dress. One bought a green dress and the other a yellow one."

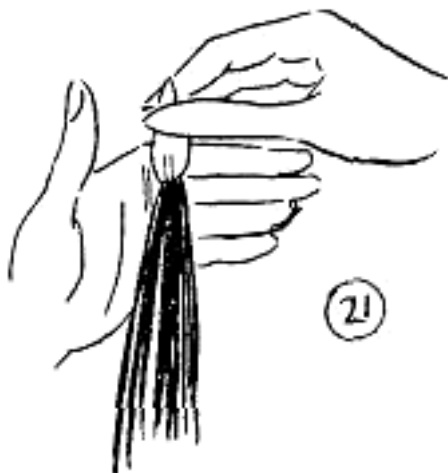
Show silks and hands freely.

"One day they happened to meet each other on the street."



Bring handkerchiefs together, placing right hand behind left so that you can grasp corner of yellow silk between first and second fingers of left hand and corner of green silk between second and third fingers of right hand.

Figure 20.



Bring corners of silks down to bases of fingers, twisting green one over to the right and yellow one over to the left. Grasp both corners in right hand, covering them so that audience cannot see them.

Figure 21 is a view toward yourself.

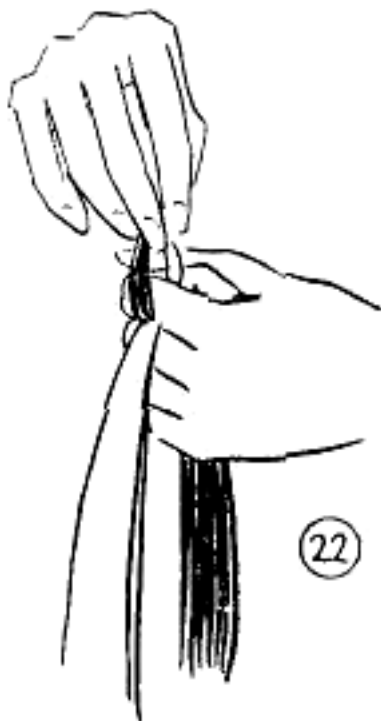


Figure 22 shows arrangement of silks and your hands as seen from audience, except that top corners of silks are quickly covered so that audience cannot see them pulled to opposite sides.

"Now the lady with the yellow dress saw the lady with the green dress and her heart sank. She wished that she had bought a green dress instead of a yellow one. The lady with the green dress saw the lady with the yellow one and she, too, felt bad for she wished she had gotten a yellow dress instead of a green one. Being a Magician, I said the Magic words and the green dress changed to yellow and the yellow dress changed to green. And the ladies were happy ever after—for a few minutes. No doubt, you would be amazed to see a lady's dress change color right before your eyes. Then watch the silks that I hold here."

Pull the two silks upward with right hand. The silks are merely changing sides and the top half of one is above the bottom half of the other. To the audience, it appears that each silk hangs straight down from right hand and changes color as you pull it through left hand.

Figure 23.

"The green changes to yellow and the yellow to green."



Pull silks clear of left hand and show left hand to be empty.

Figure 24.

NOTE:

If you wish to present this effect very simply, merely say, "These are odd silks. If I place them together, the green one changes to yellow and the yellow one to green."

* * *

(42-6)



HANDKERCHIEF TO BILLIARD BALL

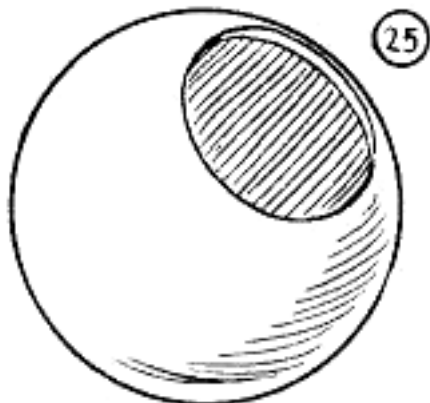
A pretty method for changing a silk handkerchief into a billiard ball.

EFFECT:

A silk handkerchief is tucked into the performer's hand and suddenly changes to a billiard ball.

PARAPHERNALIA:

1 -- A silk handkerchief.



2 -- A hollow billiard ball with an opening in it. This ball is made of wood and is painted a bright red or lacquered to suit performer's taste.

Figure 25.

We can furnish you with Red Hollow Handkerchief Billiard Balls in the 1 3/4 or 1 1/2 inch size. See price list.

MODUS OPERANDI:

METHOD 1--



Have billiard ball palmed in right hand with opening outward. Have handkerchief suspended from left fingers and show it freely. Bring hands together and work silk into opening of ball with left fingers, starting with center of handkerchief. Keep back of right hand to audience.

Figure 26.



Continue to tuck silk into ball until it is all in. Do not wave hands up and down, as is so commonly done. When silk is in ball, grasp ball in left fingers with opening away from audience and expose it, showing right hand empty.

Figure 27.

METHOD 2--

This effect is a favorite of Cardini. It is an interesting effect as silk is apparently rolled in the hands into a ball. It works nicely with a 13-inch silk and a 1 3/4-inch hollow billiard ball.



Have billiard ball palmed in left hand, keeping back of hand toward audience. Place silk over left hand and with right forefinger tuck center of silk into opening in ball. To audience it appears that you are merely tucking silk into left hand.

Figure 28.



Place palm of right hand over silk and ball. Roll right hand around and around, pushing against silk and opening of ball. This motion works the silk into the ball.

Figure 29.



In doing this, turn your right side to audience so that your hands are held out at your left side. Do not get hands too far back, however, or people sitting at right side of audience will not see them.

Figure 30 shows hands as audience sees them.



When last end of silk is almost in, reverse ball and tuck end in with left forefinger.

Figure 31.

Then hold ball in left hand as in Figure 27, showing it to audience. Casually show right hand empty.

* * * * *

THE ELUSIVE RAINBOW

(Bert Douglas)

This is a novel and humorous version of one of the most popular of handkerchief effects, the Twentieth Century Silks, in which a silk flag appears between a red and blue silk handkerchief that have been knotted together and placed in a glass. This new version is one of the best that has appeared to date.

EFFECT:

Performer displays two silks, one a medium blue and the other green. He ties them together at the corners and placing the knot in his mouth, allows them to hang down in full view. He next takes a rainbow-tinted silk from his pocket and pushes it into his left hand. This silk is vanished by bringing his left hand down smartly on top of his head. Now a corner of the blue silk is grasped in the right hand and a corner of the green in the left hand and the silks are drawn slowly from the mouth. Great is the surprise of the audience to see the rainbow silk which had disappeared, tied securely between the blue and green silks. Magician now holds the silks in his left hand and as he strokes them with the right, a billiard ball suddenly appears in his right hand. Ball is placed in left hand and hand is again struck on top of head. Ball disappears, performer opens his mouth, and the ball is taken out.

PARAPHERNALIA:

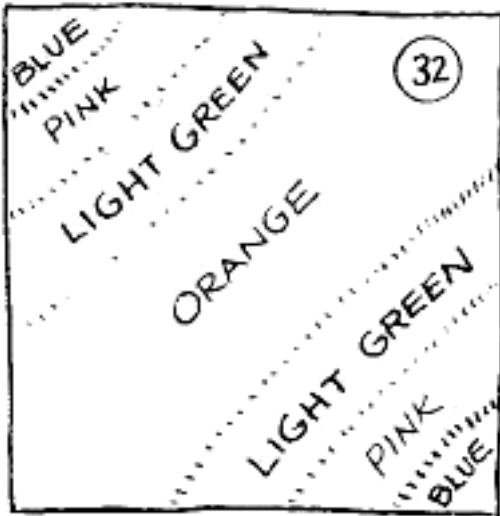
- 1 -- A medium blue silk.
- A light green silk.
- Two rainbow silks—exactly alike.

For a pretty effect, silks should be 15 to 17 inches square.

2 -- Two hollow wooden billiard balls, such as used in preceding experiment. See Figure 25. The best size to use for this experiment is an inch and a half so that it can be slipped into the mouth easily.

We can supply you with the paraphernalia for this effect --consisting of four large beautiful silks and two hollow billiard balls. See Price List.

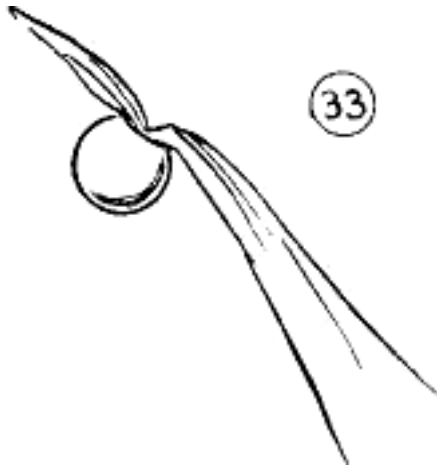
SECRET AND PATTERN:



To Prepare:

It might be well to explain here just what a rainbow silk is. It is merely a silk which has been colored in a variety of tints, thus resembling a rainbow. The silks I usually work with are arranged in colors as shown in Figure 32. The blue, pink, light green, and orange has a pretty effect.

A great variety of color combinations may be used, however. If you desire to tint your own silks, get some white Chinese silk and daub it with various colors in Diamond Dyes. Wash the silk and dip it in spots, then hang it up to dry.



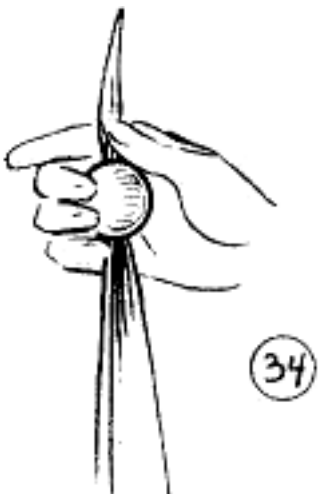
Now to prepare for the effect, tie a blue corner of the rainbow silk to a corner of the blue silk. Tuck the rainbow silk into one of the hollow billiard balls. Start with center of silk and work it in until knot is concealed in ball and opposite blue corner of rainbow silk extends about three inches outside of ball.

Figure 33.

Have silks thus prepared lying on table with blue silk covering ball. Place green silk and other rainbow silk beside the blue one. Have other hollow ball in right coat pocket or under rear part of rainbow silk. If you are doing club work, silks may be in your suitcase ready for use, or all silks may be in your right coat pocket.

To Perform:

This is an ideal number for an Oriental or silent act, as most of it is done in silence with pantomimic motions. However, introduced in a patter act, the silent parts are good and permit of comedy because of the unexpected results obtained. Your facial expression helps considerably, but, of course, it must not be overdone.



Pick up the green silk in left hand and the blue one with prepared ball in right hand. Keep back of right hand to audience to conceal ball.

Figure 34.

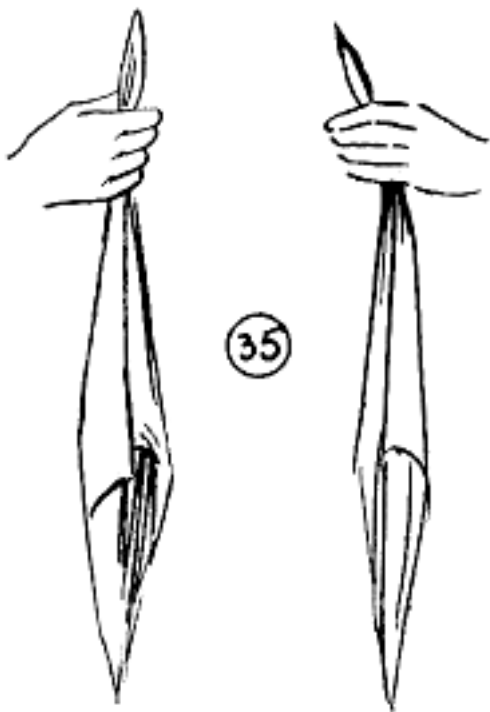
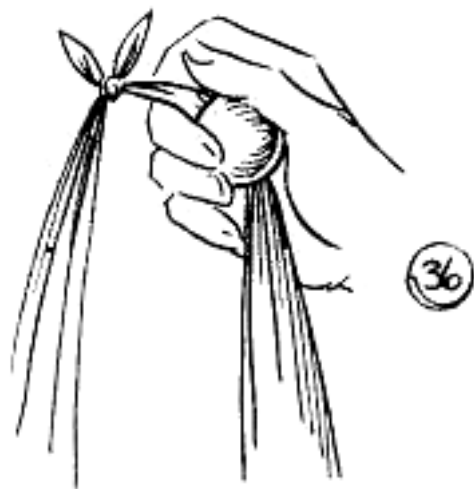


Figure 35 shows both hands as audience sees them. It appears that you merely hold a green silk in your left hand and a blue one in your right.

"The title of this little play is 'Actions speak louder than words.' It was this way. Little Boy Blue (nod to blue silk) and Susie Green (nod to green silk) fell madly in love with each other and were married. Some kind folks say knotted together."



Tie a corner of the green silk to the blue corner sticking out of the ball. Keep ball concealed all the time.

Figure 36.

"They are spliced. I'd make a good minister. Not having three hands, I shall have to hold this young couple between my teeth while I continue with the play. Naturally, with the silks in my mouth, I shall have to talk like a man with his mouth full of bananas or keep silent. Silence, being golden, wins the argument. Of course, you nor I may never know how the play comes out or what it is all about, but there are some things we must sacrifice for the good of science."



Place ball in mouth under cover of right hand, allowing knotted corners of silks to remain in full view.

Figure 37.

Pick up second rainbow silk and second ball from table or your pocket, wherever you have them. Keep ball palmed in right hand and show silk freely. Work rainbow silk into ball as you were taught in the effect, HANKERCHIEF TO BILLIARD BALL—METHOD 1.

In this case, do not expose ball but keep it palmed in right hand. After getting silk into ball, pretend to pass silk over to left hand, which closes as if it held silk. Strike top of head with left hand, lift hand and show it empty. This gives illusion of causing silk to penetrate head.

Grasp blue silk with one hand a short distance from mouth and green silk below the knots with other hand. Begin to pull slowly on silks until rainbow silk begins to emerge from mouth.

Figure 38.



While drawing silks from mouth, keep head slightly bent downward to prevent anyone from seeing ball. When silks have been completely withdrawn, close mouth quickly, retaining ball in mouth.

Figure 39.



Release hold on silks with right hand and let them hang suspended from fingers on left hand. Then hold the three silks together in left hand and stroke them with right hand. Just as you reach bottom ends, bring billiard ball to right

(42-10)



40

finger-tips and show it, carefully concealing opening. It appears that you extracted ball from the silks. You may stroke silks once and produce the ball the second time.

Figure 40.



41

Place the string of silks over the left shoulder. Pretend to transfer billiard ball to left hand, keeping it Finger Palmed in right hand. Bring closed left hand to top of head and strike head. With tongue roll ball in mouth around so that opening in it is not exposed and open mouth to show ball. It appears that ball penetrated head and came into mouth.

Figure 41.

Remove ball from mouth with left hand. While showing ball, remove string of silks from shoulder with right hand so that you can dispose of Finger Palmed ball in them.

"And the funny part is that the young couple never found out whether his grandfather slept with his whiskers underneath the covers or whether he kept them on the outside."

* * * * *

SPOT THE RED

EFFECT:

Douglas has a slightly different version of the above effect, in which he uses 13-inch silks. In this case, two white silks are knotted together and a red silk, which is apparently pushed through the head, appears, knotted between them. A white ball is then produced from the silks, is apparently thrown through the head and caused to appear in the mouth.

MODUS OPERANDI:

To Prepare:

Sew a small piece of white silk to one corner of red handkerchief. To other corner one white silk is tied.

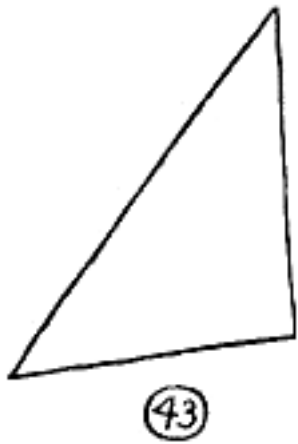
Figure 42.

Tuck the red silk into the ball until the knot between red and white silk is concealed and only false white tip of silk shows at opposite side.

To Perform:

Pick up white silk with prepared ball in right hand and second white silk in left hand. Tie a corner of the white silk to false white tip extending from ball. Now proceed with experiment as explained in preceding effect.





NOTE:

Douglas states that he sometimes cuts the red silk in half diagonally and uses only half between the other two silks.

Figure 43 shows the piece used.

When this piece is held by one corner it hangs down as a whole silk. Also when it is tied between two other silks, it looks like a whole silk. The advantage of using the half silk is that it can be tucked into a small space. This principle is valuable when you desire to produce a number of silks as the half silks show up as whole ones and you can use twice the number in the same amount of space.

* * * * *

WATCH THE LEMON

(Bert Douglas)

This is a brilliant magical problem, considered from many angles. It is full of comedy situations and still is completely baffling to the audience. There is a great deal of the element of surprise in it and the audience is kept guessing as to the outcome. It is easy and inexpensive to make up. You will be more than delighted with the result.

EFFECT:

Magician brings forward a plate with a number of lemons on it. A spectator is asked to select any one of them, examine it, and pass it around for inspection. Magician then shows an empty cardboard tube and places it on the table. He drops the selected lemon into a paper bag, stating that he will pass it invisibly from the bag into the tube. Performer now shows interior of bag and is greeted with a roar of laughter as the lemon is still in the bag. Performer, however, proves his statement is correct. He takes a knife, cuts the lemon through the middle, and shows that pulp of lemon has vanished and only skin remains. He then raises the tube and shows the pulp of the lemon to be there in the form of a glass of lemonade.

PARAPHERNALIA:

1 -- A glass of lemonade.

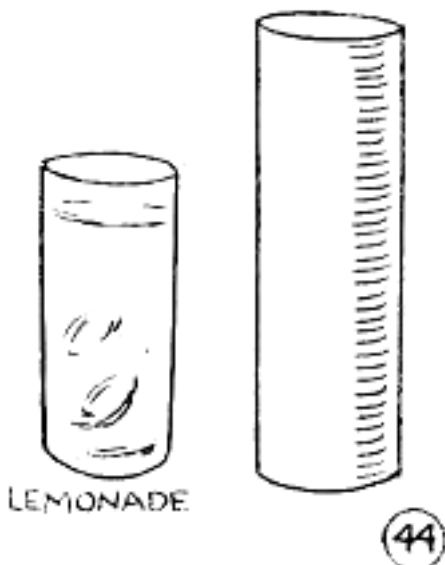
For show purposes, this may be a glass of water with pieces of lemon pulp in it. If you are giving a suitcase show and cannot have a glass of lemonade, use a bottle of lemon soda pop.

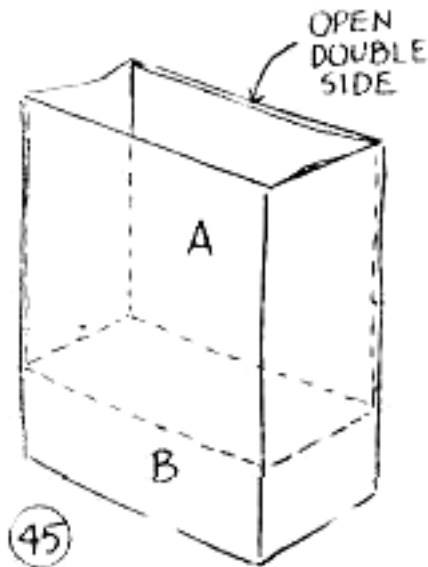
2 -- A cardboard tube.

Make this to fit easily over the glass and have it several inches taller than the glass.

Figure 44.

(42-12)

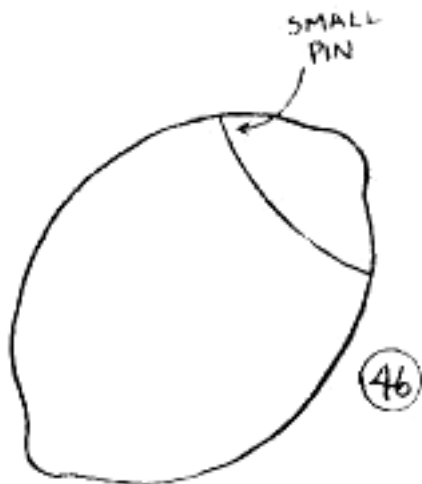




3 -- Two fairly large paper bags.

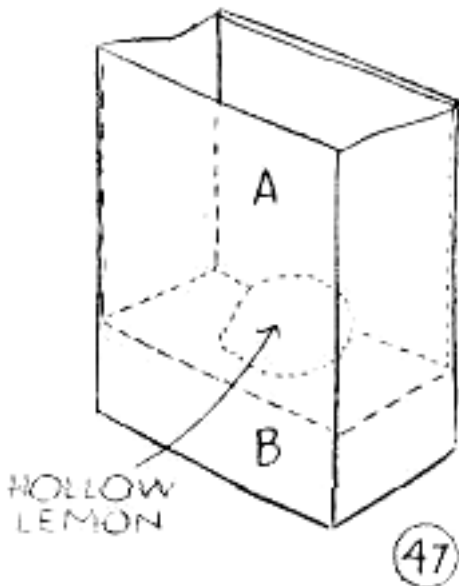
From these you make a special paper bag. Cut about three inches from the top of one of the bags and push this bag inside of other one so that the two tops are together. Now paste the two bags together on three sides, leaving one long side open. You have two compartments in the special bag--A and B. Make this bag taller than the glass and shorter than the tube.

Figure 45.



4 -- A hollowed out lemon. Take a lemon and with a fruit knife cut off the tip. With a small spoon extract all the pulp from the inside, leaving it perfectly clean. Then replace tip on lemon and secure it in place with three tiny pins. When handled right, this lemon looks unprepared.

Figure 46.



Place this lemon in compartment A of special bag.

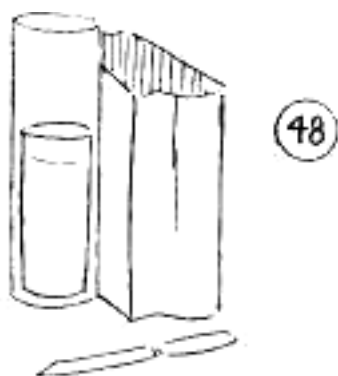
Figure 47.

5 -- A sharp fruit knife.

6 -- A plate with three lemons on it.

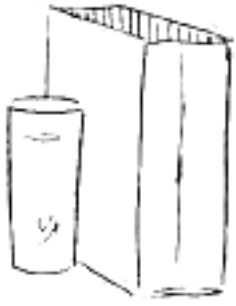
SECRET AND PATTERN:

To Prepare:



Place glass of lemonade or bottle of pop on the table. Cover it with tube. In front of this place paper bag with hollow lemon concealed. Have fruit knife lying nearby.

Figure 48 shows arrangement and relative size of the various articles.



49

Bag must act as screen for glass when tube is removed.

Figure 49 is a view away from audience. All audience can see is bag with part of tube above it.

To Perform:

Come forward with plate of lemons.

"I am always looking for new ideas and here you see the fruits of my search. I shall ask someone to select one of these lemons. Please understand that once you have picked a lemon, there can be no 'ap-peal.' Please take one yourself for I would not have it said that I handed you a lemon."

Permit a spectator to select one of the lemons.

"Thank you, sir. We can now refer to this lemon as the Best Selected Fruit. Will you kindly examine the lemon

(42-13)

closely? It is quite solid and juicy, is it not? Perhaps you would like to pass it to some of your friends to convince them that the lemon is quite innocent. Thank you."

Lemon is passed to one or two spectators for examination. Have this done quickly so that the effect will not drag. Take lemon from spectator and walk toward platform, holding lemon high up all the time so that it is never out of sight of audience. When you reach stage, place plate with two remaining lemons on a side table. Direct attention now to selected lemon.

"For good luck I am going to give you this magical problem in rhyme. When a Magic man starts put these days to think up something new, his trials and tribulations are but known to very few. There is a well known saying, 'There are tricks in every trade,' but Magic is a trade of tricks, a hundred in the shade.

"I decided to invent a trick with this yellow piece of fruit; I tried milk bottle and jam jar, but nothing seemed to suit. Twixt gluey fingers and cut thumbs I cast the thing aside, then with this tube of cardboard I finally did collide."

Pick up tube, leaving glass concealed behind paper bag.

See Figure 49.

Look into tube, then hold it up so that spectators can see it is empty.

"I picked it up and looked inside, but, as you can plainly see, it is free from tricks and traps—it's as empty as can be."



Place tube over glass again with left hand while you remove paper bag with right. Bag is lifted at moment tube is on table and completely conceals glass. This move must be perfectly timed so that glass is not accidentally exposed to audience.

Figure 50.

"So I placed it on the table and I pondered for a time -- Thinking about the tube and lemon, but more about this rhyme. Well, I came to the conclusion that my search was not in vain, For with that tube and lemon I would try to entertain."

Take lemon in right hand and place in top of tube, hesitate, and withdraw hand again, palming lemon. You may make this move very suspicious so that audience will think a false move was made and that you did not place lemon in tube. Audience believes you want to conceal true location of lemon. The surprise comes when you show that you did not want to mislead them.

"I place the lemon in the tube. No, that doesn't look quite right. So just in case of accident, we shall keep the fruit in sight."

Bring lemon to right finger-tips and show it to audience.

"Now there is a way to vanish fruit that everybody knows; but that would not be magic as you all know where it goes. So I'll place the lemon in the bag and make it disappear."

With opening of bag tilted away from audience, place lemon between the two open edges of the special bag and allow it to drop into lower compartment B. See Figure 47. There it is concealed between the two bottoms of the bag. Hold the two open edges together and tip bag toward audience to show that lemon is inside. Audience sees the hollow prepared lemon in upper compartment, but believes it is the selected lemon which was just dropped into the bag. Then tilt bag upright again.

"Keep your eyes wide open and you'll see it jump in here."

Point toward tube on table.

"Hocus Pocus Caboosa Bunka!"

Now I think I've caused our friend the lemon here to travel, in a truly magic style and a manner that will baffle."

Tilt bag forward so that audience can catch a glimpse of the lemon still in bag.

"What's that? The lemon! Oh, do not be alarmed,

I said I'd make the lemon travel and my statement is unharmed."

Remove lemon from bag, placing bag aside. Pick up fruit knife from table and cut lemon through the middle. Take the two halves apart and show hollow insides to audience.

"For, as you see, the lemon has flown—only the skin remains;

And what the bag here loses, why the tube most surely gains.

But a lemon without a skin would be an awful sight;

So it's up to me and my Magic to set the matter right.

"I make a pass quite slowly—to rush it never paid, And I'll restore the lemon. . . ."

Make a mysterious pass over the tube, then lift tube from glass with left hand.

"In the shape of lemonade."

Show tube empty and pick up glass of lemonade with right hand, showing it freely.

In club work, you may pass lemonade out to a spectator. If using a bottle of lemon pop, you may open bottle, pour contents into a glass, and pass it out—or just keep bottle closed for next show, if you prefer.

THE MAGIC CHOCOLATES

(Bert Douglas)

This is a charming problem with properties seldom used by Magicians. The effect is puzzling, yet the secret is very simple.

EFFECT:

Performer shows a box of chocolates and empties it into a glass candy jar. The jar is then covered with a silk handkerchief. The cover is placed on the box and it is set aside on table. Magician now produces his magic whistle and things begin to happen. Handkerchief is removed from glass jar, and candy has vanished. Box is opened and is found to be filled with chocolates again as in the beginning. Candy may be sampled, if desired.

PARAPHERNALIA:

1 -- The large confectionery jar, a special piece of apparatus, known as the Mirror Jar. This is a very handy piece of apparatus as many effects can be performed with it. Any articles of suitable size may be caused to vanish, appear, or change in this jar.

From the outside jar looks like ordinary candy jar. The apparatus consists of jar, top, and a metal insert, highly nickeled and polished on both sides. This insert divides jar into two compartments. The reflection cast by the nickel insert produces an optical illusion and the jar appears empty even when something is behind the insert. Flat side of insert is kept toward audience and they look directly into polished surface.

Figure 51 shows outside of jar.

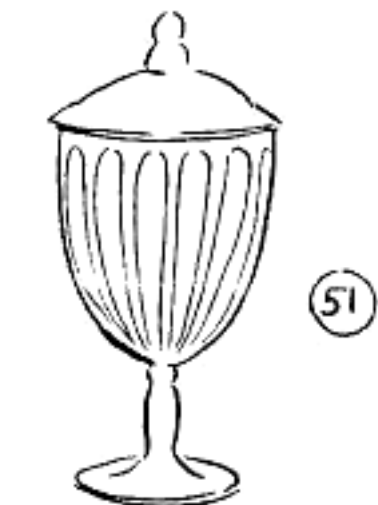


Figure 52 shows metal insert.

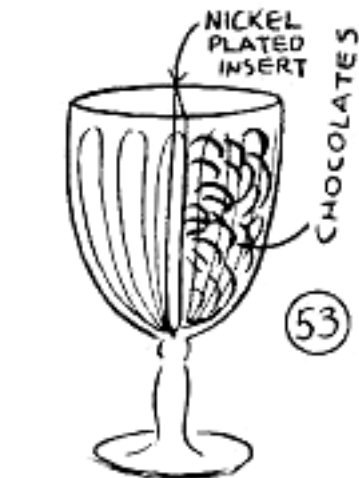


Figure 53 shows arrangement of insert with articles behind it.

We can furnish you with a Mirror Jar. See Price List.

2 -- A dark-colored silk handkerchief to cover jar.

3 -- A pound box of chocolates, consisting of two layers. Get a nicely decorated box in which a cardboard tray holds the top layer. On examining the box, you will discover that tray rests on a cardboard support around the bottom of the box. If this support is loose, it should be glued against sides of box.



(54)

Figure 54 shows outside of box of candy.

(55)

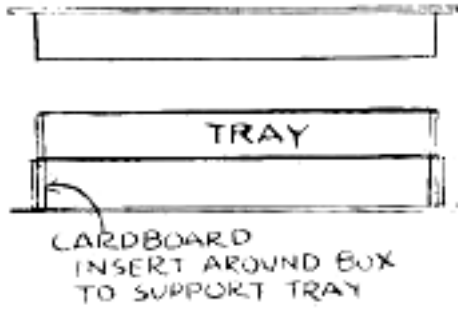


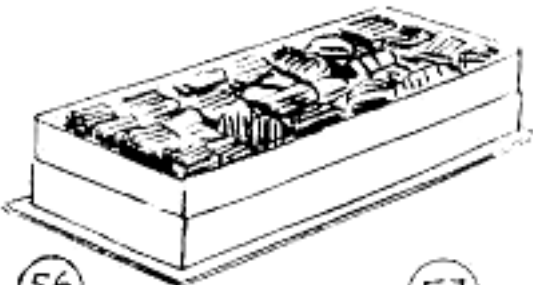
Figure 55 shows construction of two-layer box.

4 -- An extra half-pound of chocolates, such as are in upper layer of box.

SECRET AND PATTERN:

To Prepare:

Remove lid from box and also the tray of chocolates. Place tray on table, covering it with lid. To audience it appears that cover of candy box is merely lying on table. Have lid and tray extending over edge of table a little so that they can be picked up easily.



(56)

Place the extra half-pound of candy on top of those still in box to refill box. Place box on table near lid.

Figures 56 and 57.

Have candy jar on table, some distance away from box and lid. Place handkerchief nearby.

To Perform:

Direct attention to candy jar.

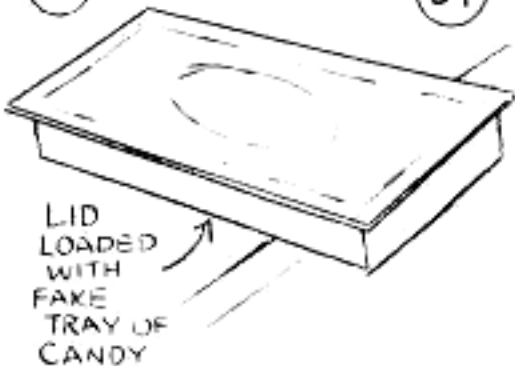
"In days gone by, the candy jar used to be very popular. Now and then we still see a few of them in which candies are displayed. The box of candy, however, has come into its own."

Pick up box of candy and show to audience.

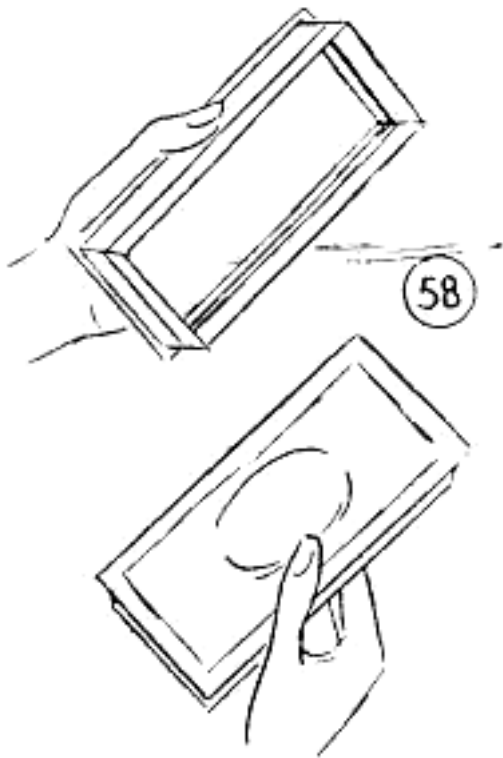
"I remember when I was a boy I worked for a country groceryman. When candy came in boxes, I used to have to empty the boxes and put the candy in confectionery jars."

Pour chocolates from box into front compartment of candy jar. It appears to audience that you are filling candy jar with chocolates.

"It was hard for the grocer at that time to get it into his head that the box idea was more modern. Perhaps he stuck to his jar idea because he usually sold a nickel's worth of candy at a time."



(57)



Show box empty and hold it in left hand. With right hand casually pick up lid with tray of chocolates under it and place on box. Close box and place on table in full view.

Figure 58.

"I used to give most of the boxes away to be decorated for jewelry cases or May baskets."

Pick up jar of chocolates.

"Late Saturday night I used to cover over the jars of candy so they would not be displayed on Sunday, perhaps due to a religious belief on my employer's part that people must not be enticed on Sunday to the luxuries of life."

Cover jar with silk handkerchief and put cover on it. Hold jar in right hand. Now turn toward the left to place jar on table. This move automatically brings empty compartment of jar to the front and filled compartment to the rear. Place jar on table turned in this way.

"Now and then some particular city beau who was calling on one of the belles of the town was not satisfied with bringing his sweetheart a nickel bag of candy, but would want a whole box of it. I would have to go to the candy jar and fill up the box again. Filling a box was more or less of a nuisance. Why not leave a box or two under the counter in readiness? But no—the groceryman wanted his candy in the jars. One day, when a city fellow came into the store for a box of candy, I hit upon an idea. Why not use Magic and save time? So when I lifted the cloth off the jar, the candy was gone. ..."

Remove silk handkerchief from jar to show that chocolates have vanished. Audience sees front compartment of jar to be empty. They look directly at nickeled insert and it looks as though they can see through the jar.

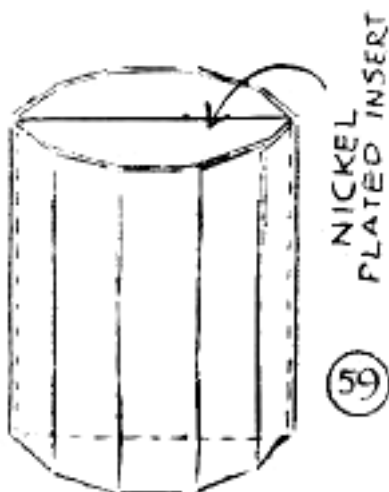
Replace silk on table. Pick up box of chocolates and remove lid, showing box to be filled again. Top tray of chocolates serves to give impression of full box.

"And the box was filled ready for delivery."

NOTES:

Another way of performing this experiment is to have the chocolates already in the jar and to show the box empty. Then continue experiment as taught to you above.

Or you may have chocolates in a bag and pour them into jar from that, then proceed to empty jar and fill box as before.



There are a number of ways in which a box of chocolates can be vanished. Another type of mirror jar may be made by using a jar shaped like that in Figure 59. In middle of jar insert two pieces of mirror back to back.

Another way in which I like to work is to use a table with a black art well (a hole in table in which a bag is arranged to catch articles--this is explained to you farther on), or to use a servante on back of table. I use a glass bowl with decorated sides and cut the bottom from it. The missing bottom is not noticed by audience. Have bowl on table proper, pour chocolates into it, and cover. Move bowl over black art well and allow chocolates to fall into it, or bring bowl over back edge of table, allowing chocolates to fall into servante. Replace bowl on table or raise it up, remove covering, and show that chocolates have vanished.

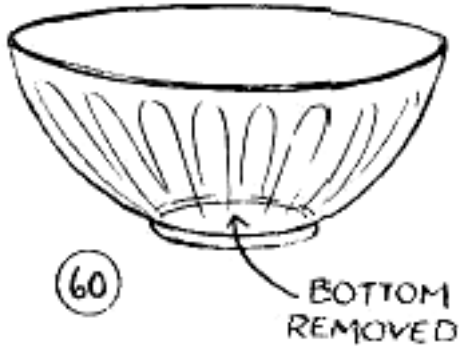


Figure 60.

The bottomless idea with glassware is good. The bottomless glass has long been used in Magic. It is just an ordinary glass tumbler with bottom removed. Articles are placed in tumbler and secretly removed from bottom under cover of a silk over the glass.

* * * * *

POPPING CORN IN A HAT

This is a great number to perform when there are children in the audience. It is simple to prepare and to perform.

EFFECT:

Performer lights a candle and gives it to a boy to hold. He then asks boy to take a handful of raw popcorn out of box. Boy places this in an empty borrowed hat. Hat is held over the candle flame and soon grains of popcorn bounce over the hat. Magician turns hat over and pours out half a hatful of popped corn on to a piece of paper for the boy to pass out to his friends.

PARAPHERNALIA:

- 1 -- A borrowed hat from audience.
- 2 -- A candle in a candlestick.
- 3 -- Some unpopped and some popped corn.
- 4 -- A sheet of paper.
- 5 -- A special box.

This appears to be an ordinary box containing unpopped corn, but in reality it is loaded with the popped corn and is arranged to drop popped corn into hat at proper time.

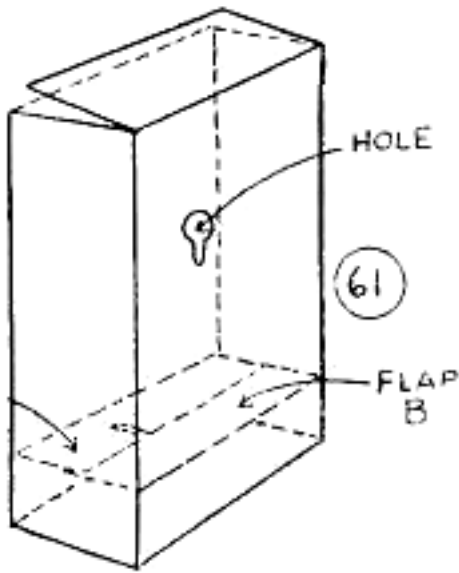
SECRET AND PATTERN:

To Prepare:

To construct box--

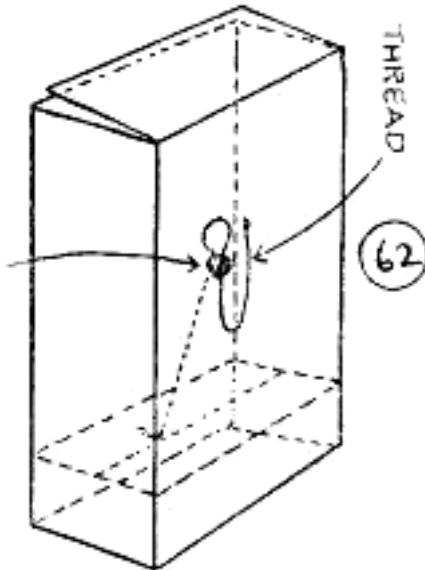
Get a package of cereal from the grocery store. A Puffed Rice box works nicely. I use a box about 6 x 9 x 3

inches. The box you use should be of cardboard and of such size as to slip down easily inside a hat.



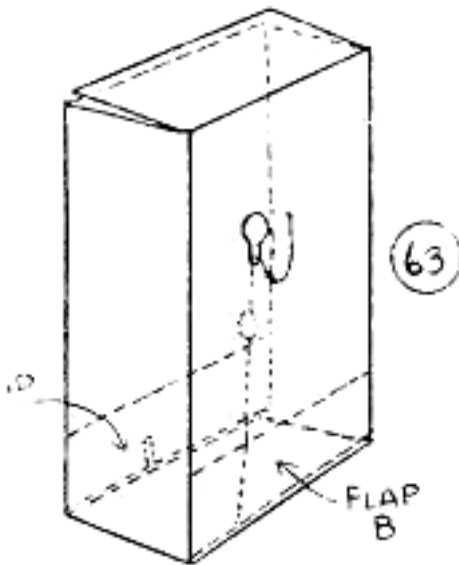
Open the top of box carefully and remove contents. Carefully cut out the bottom. Take two pieces of cardboard which will fit into box horizontally, overlapping about a quarter of an inch. Place these several inches up from bottom of box. Hinge each flap to box by gluing a piece of cloth to the box right above flap and then to flap itself. Cloth makes a flexible hinge and allows flaps to hang down when box is empty. Have flap A above flap B. Cut about an inch slit in flap A at point indicated on diagram. In back of box proper cut out a keyhole shape.

Figure 61.



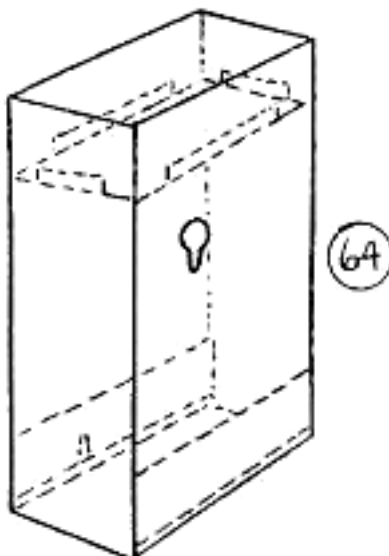
With a needle and stout linen thread or piece of string, sew through edge of flap A at point where there is slit in flap A. Bring thread up through this slit and then out through small part of keyhole. Have thread just tight enough to hold flaps up across box and attach a button to thread just outside of keyhole to hold thread. Leave a loop of thread and attach end to box proper.

Figure 62.



Raise the button and it slips through larger part of keyhole to inside of box. This causes the two flaps to fall downward. Thus when button is set and anything is placed in box, it is held securely. But if button is released, flaps fall downward leaving bottom of box open and causing material in box to fall into whatever receptacle is below it.

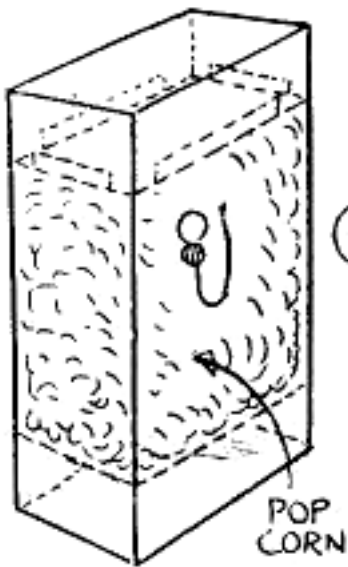
Figure 63.



About two inches down from top of box, place a piece of cardboard to fit across box and divide it into two compartments. Glue this piece in with pieces of cloth.

Figure 64.

Now take your popped corn. Have it just plain with no butter, grease, or salt, which would spoil a hat.



(65)

Turn box upside down and fill it with popped corn. Fold down flaps against corn and pull button into position on outside of box to hold flaps in place. Turn box upright again.

Figure 65 shows arrangement of popcorn in box.

Place unpopped corn in top compartment of box. In performing never expose bottom of box or back of it. From the front and top it looks like an ordinary box containing unpopped corn.

(42-20)

Figure 66.

Have box on table with front of it facing audience. Have candle in candlestick nearby with box of matches handy. Have sheet of paper handy also.

To Perform:

(66) Borrow a gentleman's hat and request a young boy to come up from audience to assist you. Place boy at your right. Ask him his name, and after suitable introduction, continue with effect.

"John, you look like the sort of boy who would be of great help to mother and could even help her cook the meals. Did you ever do much cooking?"

Get candlestick with candle, also matches from table. Give candlestick to John to hold.

"Do you know, John, that cooking has changed quite a bit from what it used to be. It used to be quite primitive."

Strike match and light candle. Have boy hold candlestick in left hand.

"Yet with all pur modern ways of cooking, it is well to know some of the earlier methods—especially when you are out in the open, away from home. By the way, John, are you a Boy Scout?"

If he is a small boy, he naturally wouldn't be a Scout. If an older boy, he may be. Handle patter accordingly.

"No? Well, when you get older you no doubt will be. Now good Scouts know how to cook in a simple manner. They use sort of an Indian style."

Pick up borrowed hat in left hand and prepared box in right. Have right forefinger in such position behind box as to be able to release button readily when time comes.

Figure 67.

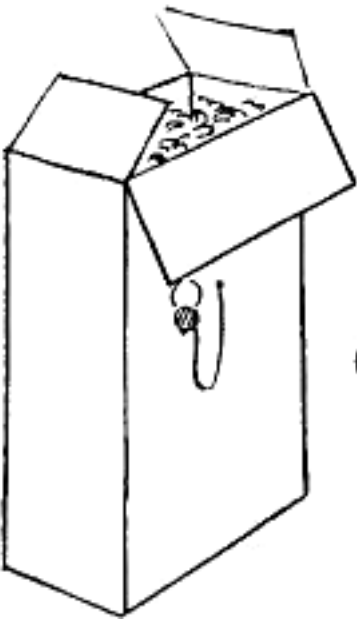
"John, what would you think of a hat for a stove? A hat should hold quite a meal."

Show hat empty to convince audience that you use no trick device in it.

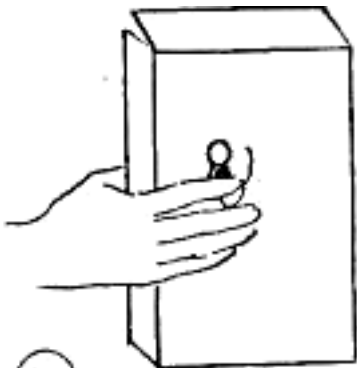
"I feel quite sure that the man who so kindly let us have his hat would have no objection to our using his hat for a stove."

To gentleman in audience:

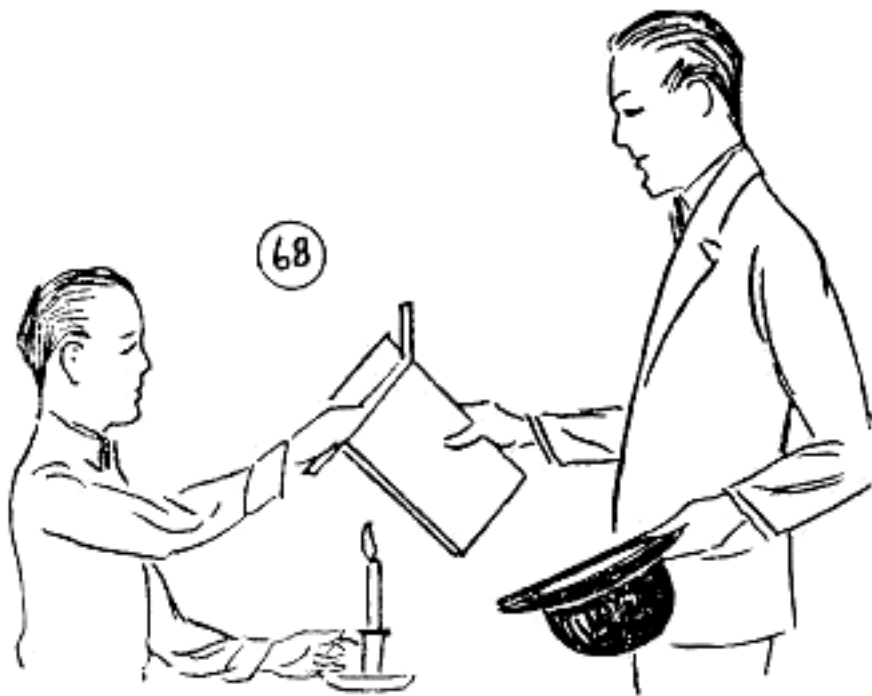
"You have no objection, have you, sir? No, of course not. Now, John I have a box here pretty well filled with unpopped corn. Reach in and take a handful."



(66)



(67)



Turn toward John and extend the box so that he can reach in and take a handful of unpopped corn.

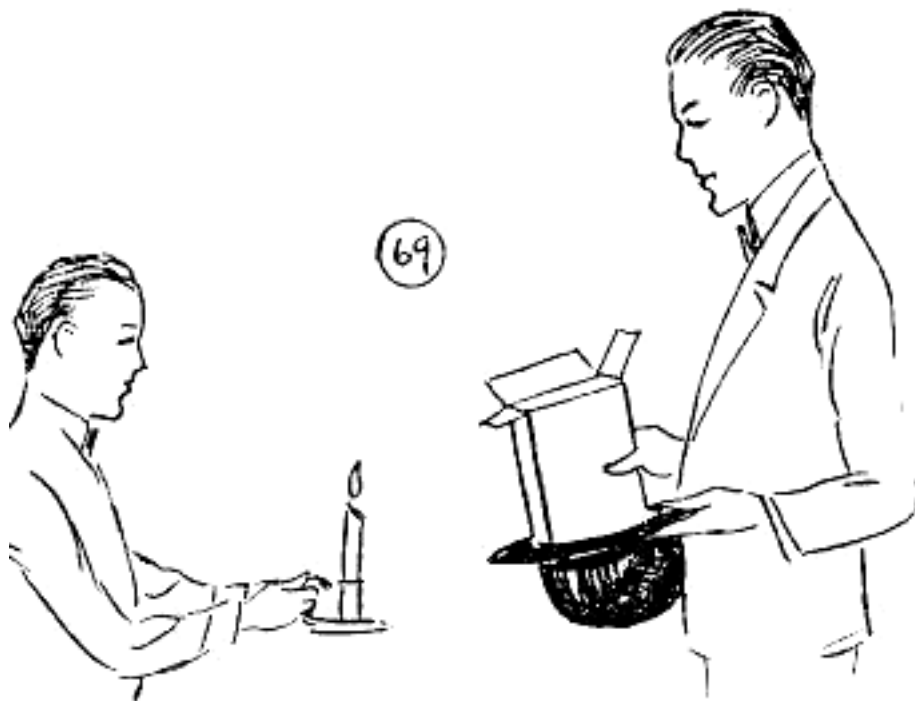
Figure 68 is a view of yourself and boy as audience sees you.

"It is very good corn, John, even though the grains are a bit sharp. They are good and dry. Now you can just drop the grains of corn into the hat. That's right—put the whole handful in."

Boy drops corn into hat.

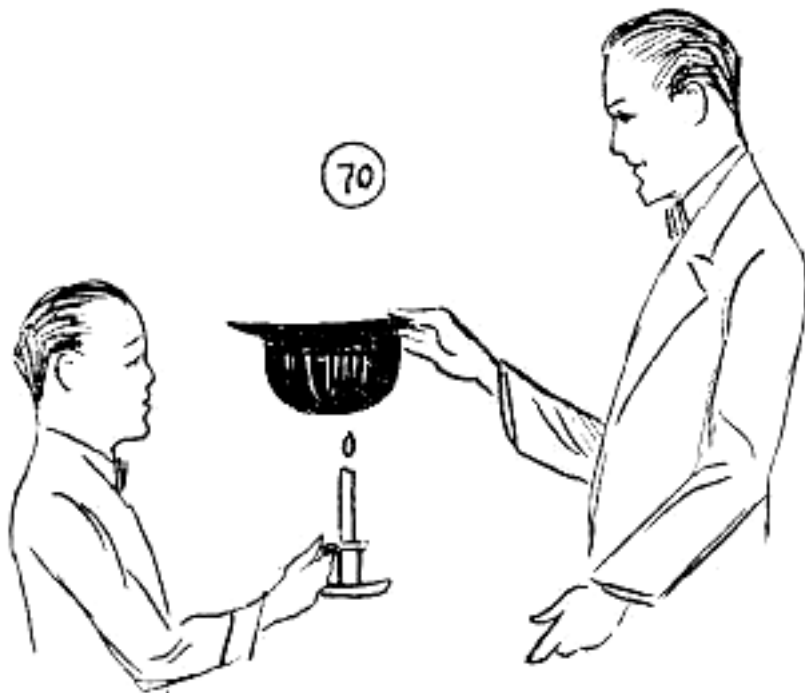
"Oh, I forgot, John, you are holding the candle left—you should hold it right. Hold it with your

right hand."



As you direct attention to John, bring box down into hat a little way. Push button up with right forefinger. This releases flaps and causes popped corn to fall into hat.

Figure 69.



As soon as corn is well within the hat, remove box. Hold box low so that bottom will not be exposed and place it aside on table. Hold hat above boy's eye-level so as not to expose popped corn in hat.

"That's better now. I suggested using this gentleman's hat for a stove, but now that we have popcorn in it, I suggest that we use the lighted candle for the stove and the hat for a popper. You keep hold on the stove, John, while I do the popping."

Move hat back and forth over lighted candle as you would a popper. Keep hat about six inches above flame so as not to injure hat.

Figure 70.



Increase speed of your motion to cause a grain or two of corn to jump out. Continue to cause grains to jump out one or two at a time. You can imitate popping effect very nicely by control of the hat. Finally cause several grains to jump out. Slow down motion as you would in regular popping.

Figure 71.

"Well, John, I guess most of the grains have popped."



Take candlestick from boy and place it aside. Give him sheet of paper to hold spread out between his hands. Pour the corn from the hat out on to the paper.

Figure 72.

"There you are, a nice hatful of popped corn. Take it down and let your friends help you have a popcorn feast. It will make them appreciate from now on just how good a cook you really are."

Help John down from stage. Then return hat, saying:

"I shall return the gentleman's hat to him. You will find it unharmed, sir, and, no doubt, you will be popping a bit of corn in it yourself occasionally."

Harlan Tarbell

TARBELL SYSTEM, INCORPORATED, Chicago.

* * * * *

NURSING BOTTLE FROM THE HAT

This may be used as a comedy addition to above effect.



Get a flat nursing bottle, fill it three-quarters full of milk, and stop the nipple to prevent leaking. Place bottle in special pocket inside of left side of coat. Have opening of pocket in the side toward the front edge of coat.

Figure 73.

After you have performed preceding experiment and are helping boy down from platform. Get behind boy, and under cover of hat, reach into pocket with right hand and get nursing bottle into hat. Just before returning hat to gentleman, remove nursing bottle from hat and show to audience.

"Pardon me, sir, I didn't know you carried the baby's lunch in your hat."

* * * * *

LESSON 43

A big lesson in PRODUCTIONS, featuring the production of many eggs from an empty hat. This effect is excellent for injecting comedy into your programs as it is invariably greeted with a roar of laughter as the eggs are piled up on a boy's arms, and some fall on the floor and break.

You are taught how to remove a rabbit or a chicken from a gentleman's coat in a manner truly magical.

Also the production of various articles from a hat, including a RABBIT.

COAT AND HAT PRODUCTIONS

This lesson deals with production work, particularly that of taking objects from an empty hat and from a spectator's coat. There seems to be something unusually fascinating about this Magic. How well we all remember the magician who produces almost anything from a hat or gentleman's coat! How marvelous seemed the mystery man who pulled a live rabbit from an empty hat! And now you learn these interesting productions.

Productions included are eggs from a hat, a master hat production, rabbit production from hat, from silks, from paper ribbon, from spectator's coat, chicken production from coat, production of bottle from spectator's hip pocket, change of rabbit to candy, production of sausages from boy's coat, and general hat productions.

Production work divides itself into two branches:

1 - Outside Loading. Effect is started with object really empty, and then through misdirection, production articles are loaded into object so that they may be taken out a moment or so later. This type of Magic would be necessary, for instance, when a borrowed hat is used. The hat is empty, of course, and the articles to be produced must be slipped into the hat unobserved. There are many places where articles or "loads" can be concealed and slipped into the hat secretly with natural movements which will not excite suspicion.

2 - Self-contained load. In using this method, the finish of the effect is already there in the beginning. By this I mean that the finished effect which the audience will see is carefully camouflaged, and it is merely a question of getting rid of the camouflage to complete the effect. For instance, a hat is shown to be empty but, in reality, it is half filled with the objects that are to be produced.

Both kinds of productions have their places in Magic, and it is the wise magician who uses both in his work.

In Lesson 30 you learned how to load silks into a hat from the outside. In Lesson 42 you learned how to load popped corn from a camouflaged box into a hat. This gives you two examples of effects under the first type of production. It would be well to review these effects. In today's lesson you learn effects which come under the second type of production as well as the first.

* * * * *

COMEDY EGG PRODUCTION

This effect has been a great feature number with Thurston in this country and with Devant in England. I remember

seeing Thurston a number of years ago take many eggs out of a hat and pile them up on a boy's arms while the audience went into gales of laughter. Thurston had his pet presentation, as did Devant, and many others who have since performed this interesting comedy effect. It would be an education for you to study the way Thurston and Devant handle children.

I am going to teach this effect to you by a method which I have found very easy to perform. Brunel White of England introduced a special hat some time ago which has made egg productions easy under almost impossible circumstances. I have performed the eggs in the hat by this method while standing on a table with an audience of children all around me.

EFFECT:

Performer has a small girl and a boy come up on stage to help him. He shows a derby hat to be empty and then suddenly discovers a real egg in the hat, which he gives to the boy to hold. One at a time, magician takes many eggs from the hat and gives them to the boy. Every time little girl blows on bottom of hat or performer's hand, an egg appears. Finally, the eggs become so numerous that the boy cannot hold all of them, and they slide down onto the floor and break, much to the amusement of the audience. Every time an egg hits the floor, the audience almost goes into hysterics. Finally, the supply of eggs stops and those eggs in boy's arms are replaced in the hat. Little girl and boy go back to their seats.

PARAPHERNALIA:

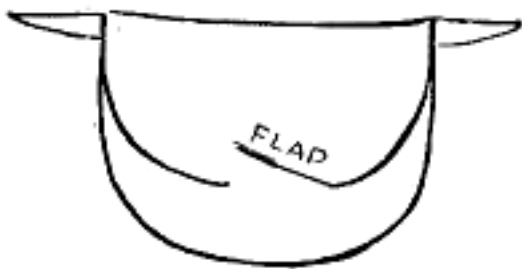
- 1 -- A Master Hat -- construction of this is explained to you.
- 2 -- Twelve to eighteen eggs -- as many as you can conveniently get into prepared portion of Master Hat.
- 3 -- A piece of paper or rubber sheeting on floor upon which eggs can be dropped.

SECRET AND PATTERN:

To Prepare:

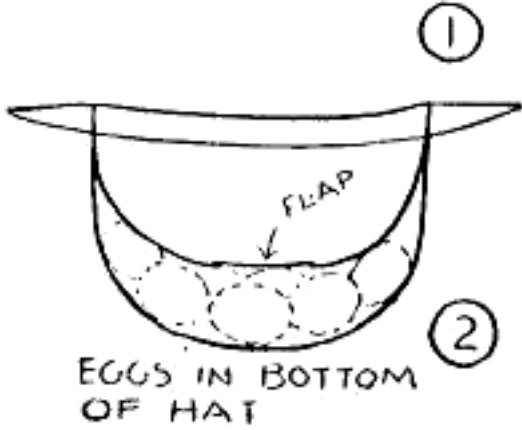
The Master Hat -- This is not difficult to make and yet it is very effective. It is based on an idea in hat Magic conceived by Brunel White of England. He has brought out quite a number of clever ideas, but this hat alone should make his name go down in magical history.

To make up this hat, it is necessary to invest in two black derby hats. Get one in a large size and the other in a size to fit into the first. While you are at the store, turn sweat-band of large hat out and fit a hat into first one to make sure that one crown fits inside of the other. Do this before purchasing hats so that you get the proper sizes.



Take the smaller hat and cut the brim off. Raise the inner band of larger hat and sink the brimless crown into it about half-way. Explanation of the flap comes a little farther on.

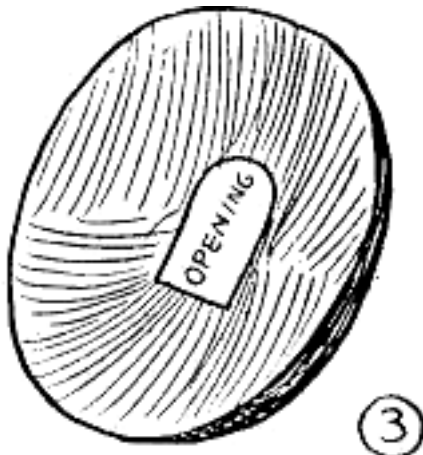
Figure 1.



The best way to determine how far the crown should go down inside of the other hat is to place about a dozen or more eggs on bottom of hat and then place crown down on top of them.

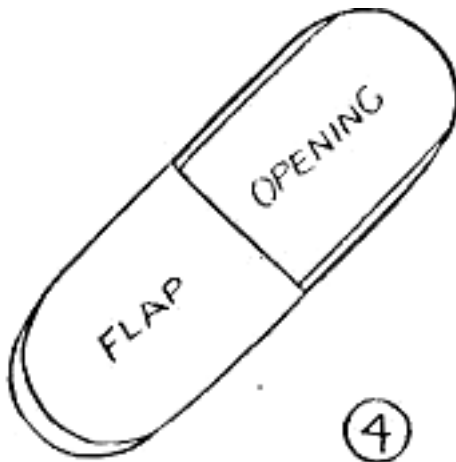
Figure 2.

Now cut down crown so that it comes just below edge of hat. Fold inner band of hat down inside of false crown, covering the edge. One can look into hat from a distance of a few feet and it looks like an ordinary hat.



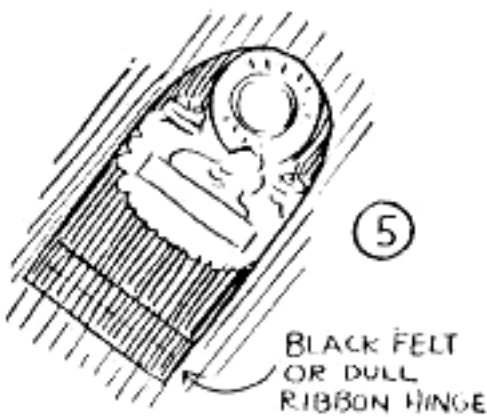
Raise inner band of hat again and remove false crown. In center of false crown cut out a rectangular piece, straight at one end and rounded at the other. Hole should be large enough to permit you to reach down with your hand and pull an egg through it. Cut hole with sharp knife so that edges are even as piece cut out is to be used as flap.

Figure 3.



On two long edges of opening glue strips of black felt or dull ribbon. Fit flap into opening and glue a piece of black felt, black cloth, or dull black ribbon over straight edge to act as hinge.

Figure 4.



Remove trade-mark label, mount it on piece of stiff black cloth or cardboard, and glue it on flap with one end extending over free edge of flap about a quarter of an inch. This little edge gives you something to grasp easily when you wish to raise flap.

Figure 5.

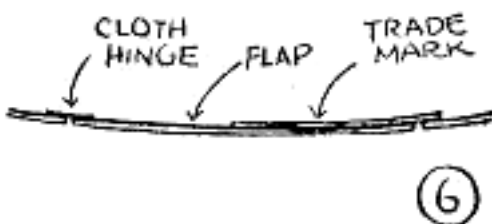


Figure 6 is a diagram of arrangement of flap in false crown.



With false crown placed in hat, inner band down over edge, and flap down flat, inside of hat may be shown empty even though the concealed compartment between the two crowns is full of articles. Then when flap is raised, articles can easily be removed from bottom compartment.

Figure 7.

Place eggs in bottom compartment of prepared hat and close flap. Place an egg in right coat pocket. Put the paper or rubber sheeting on floor at right of stage.

(43-3)

To Perform:

Come down to audience, palming egg out of right coat pocket as you do so. Produce egg from a gentleman's whiskers, chin, or ear.

"I was just going to ask someone to lend me a fresh egg, but the gentleman here has anticipated my request and has already accommodated me."

Pick out a little girl in audience and give her the egg.

"Just look this egg over carefully and see whether it is a good egg. Oh, pardon me, someone in the back is making motions as though he cannot see the egg. Just stand up and hold the egg high in the air."

Get little girl to stand up and hold egg up high.

"Or, better yet, just come with me up on the stage."

Take girl up on stage. Ask her name, shake hands with her, and then introduce her to audience. Suppose her name is Ruth.

"Ruth, I want you to meet the audience. Audience, I want you to meet Ruth. By the way, Ruth, do you happen to see any boy down in the audience that you would like to have help you hold the egg? Just point to any boy that your heart chooses."

When she has pointed to boy, say:

"We shall just go down and give him the egg."

Go down into audience with Ruth and give boy the egg. Get him to stand up and come out into the aisle, then finally get boy and girl up on stage. Have girl stand at your left and boy at right on the paper or rubber sheeting.

"Now, Ruth, you can stand on this side of me and you stand about here with the egg."

As you talk to boy, take him by wrist of hand in which he holds egg and move him towards yourself a little. As you do so, push egg out of his hand with your thumb or finger so that it will fall to floor. Your movement must not be perceptible to audience. You must give impression that boy dropped the egg. Audience laughs and boy usually feels discomfited. Look at boy, then at egg on floor, then at boy, at audience, at Ruth, and at boy again.

"Oh, well, do not worry about the egg. I'm sure the gentleman will lay us another."

Ask boy his name -- suppose it is Burt. Shake hands with him.

"Well, Burt, I'm mighty glad to know you. By the way, Ruth, did you ever meet Burt?"

Move her over in front of you and have boy and girl shake hands.

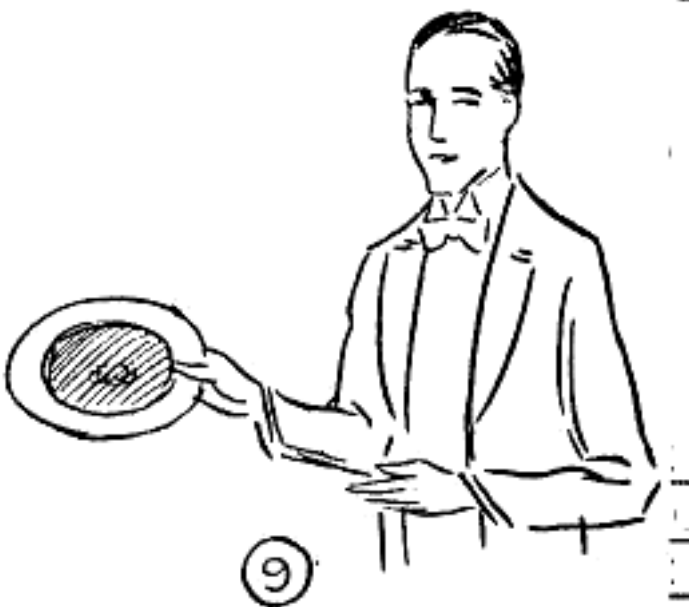
"Ruth, this is my old friend, Burt. Burt, this is my good friend Ruth. Now that we all know each other, we can have just the finest kind of a time."



Reach over to table and pick up Master Hat, containing the eggs. Hold hat in left hand and take your position between girl and boy.

Figure 8.

"Burt, did you ever wear a derby hat? There used to be a season for wearing brown derbies, but we couldn't find any more brown sheep to make hats out of so we had to use the black ones. A funny thing happened just before the performance tonight. I had this hat on a table behind the scenes, and when I went to get it, what do you think I found? - A hen sitting in it, using it as a nest."



Show hat empty by turning it so that audience can see directly into crown.

Figure 9.

"Burt, I suppose the inside of a hat would make a nice nest. I thought there might be an egg or a couple of little chickens in the hat, but when the hen scurried away, there was nothing left but a small feather or two."

Show Ruth the inside of hat for a moment.

"I guess, Ruth, we got all the feathers out."

This is an interesting piece of psychology here. It convinces audience that hat is empty without saying so. The fact that Ruth looks into hat at close quarters after they had looked into it from a distance adds to their

convictions.

At this point I might mention a psychological trick employed by a prominent magician in an emergency. I was in my teens when I saw this done and it puzzled me as well as the audience. It shows how a magician can be master of a situation by his ability to make an audience think as he wants them to. This magician took a hat actually filled with eggs. He did not show inside of hat to audience, but in order to convince them that hat was empty, he had the little girl look into it. His talk was such that the little girl did not suspect magician was giving impression that she was looking into empty hat. The spectators' minds were directed so that they imagined she was looking into empty hat, and when eggs were produced, they seemed to materialize from nowhere.

"Well, Burt, I got to thinking and was just wondering whether it wouldn't be good fun for us to use our magical

(43-5)

powers and make this hat play the part of a hen and lay us an egg. Of course, Ruth, it will be necessary for you to blow on the palm of my hand or on the bottom of the hat to get enough warmth to materialize things."

Have her blow on palm of your hand. Now reach into hat and, lifting up flap, remove an egg. Bring it up out of hat and show to audience. While doing this, hold hat up high enough so that children cannot see into it.

"There's an egg. Looks like a good egg to me. Look it over, Burt, and give us your opinion."

Give egg to Burt and whisper to him to smell of it. This brings a laugh from audience.

"All right, Burt, you keep the egg. Now, Ruth, blow again."

Have her blow inside of your hand again, then reach into hat and take out another egg.

"Burt, it looks as though our egg factory is working and that we can dispense with real hens."

Give second egg to Burt. Then continue production of eggs, giving them all to Burt to hold.

After he has several eggs and can no longer hold them in his hands, fold his arms for him so that he can hold the eggs in his arms. To vary productions, have Ruth blow on bottom of hat at different times for comedy. After fifth or sixth egg is produced, turn down flap and show hat empty again.

After boy has a number of eggs in his arms, hand him an egg at his left side just high enough so that he will have to reach for it, causing an egg to slide out from the right side and go crashing to the floor. As you repeat this, pretend to be interested in the hat and do not look at boy so that movement of holding eggs too high for him will seem natural.



The audience is kept in suspense, waiting for an egg to fall from boy's arms. And when an egg does fall, it means a burst of laughter. It is well to allow four or five eggs to drop and break.

Figure 10.

After all eggs have been removed from hat, take eggs from boy's arms and replace them in hat. While removing eggs from boy's arms, cause one or two more to drop, which provokes more laughter. Then shake Burt's hand.

"Burt, you did nobly. An incubator could have held them no better. Goodbye, Burt, come back and help me again sometime."

(43-6)

Boy starts for seat.

"Oh, just a minute, Burt. Ruth is going your way, and I'll let you see that she gets to her seat all right."

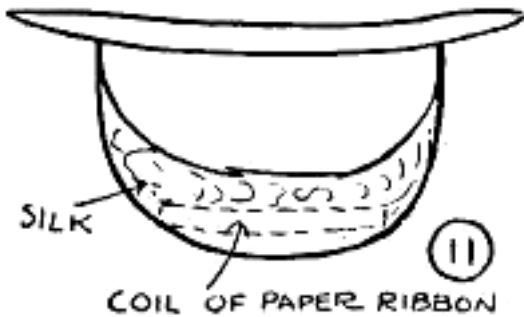
Shake Ruth's hand.

"Goodbye, Ruth. I want to thank you for making the eggs appear. You blew fine."

Boy escorts girl to seat.

* * * * *

A MASTER HAT PRODUCTION



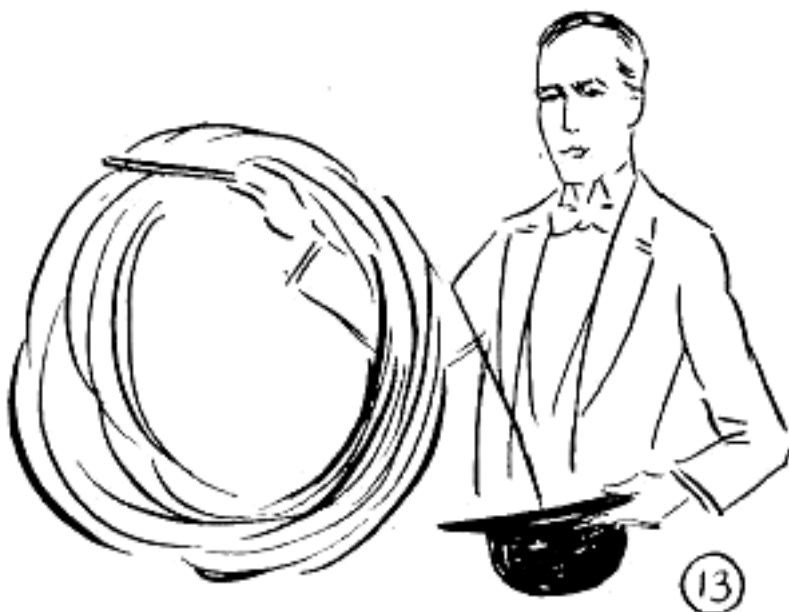
Remove false crown of Master Hat and place a roll of paper ribbon on bottom of hat proper. Readjust false crown in hat. Open flap and tuck silk handkerchiefs and silk streamers into secret compartment. It is surprising the amount of fine silk which can be tucked away in compartment. Close flap.

Figure 11.



It is easy to produce silks by merely reaching into hat, opening flap, and bringing silks out.

Figure 12.



After silks are produced, hat is shown empty. Then reach in and start the roll of paper ribbon from the center. By turning wand in right hand around in a circle, this production is made very effective.

Figure 13.

Silks and ribbon may be used later for a rabbit or guinea pig production.

* * * * *

RABBIT PRODUCTIONS

The rabbit has won for itself a fine place in Magic. When there are children in the audience, the production of a rabbit is greeted with much hilarity. Something live is appreciated by the youngsters. And as grownups are really only boys and girls grown up, they too admire the appearance of Professor Bunny.

Rabbits are by no means difficult to handle if you use a little care. I am simplifying rabbit productions for you so that you can produce a rabbit from a hat, from under a gentleman's coat,

from a bunch of silks, a mass of paper ribbon, etc., with ease and naturalness and good effect.

(43-7)

The first thing to consider is HOW TO CONCEAL A RABBIT. This must be done in a way which will not excite suspicion on the part of the audience and will allow you to get at him easily at the proper moment.

In Lesson 30 I taught you how to conceal bunny in a special bag which can be opened easily and how to hang bag on back of chair or table on a headless nail. Once you understand the main principles in this type of rabbit production, you will have no trouble in concealing him or getting at him for production. When using a large rabbit, this type of production must be used. Also when working on the stage with all necessary properties at hand, this production is easy to accomplish.

For work in the audience or out in front of the stage away from properties, however, it is well to conceal the rabbit on your person. In this work, use a small rabbit or a guinea pig so that he will not bulge your clothing out too much. Now we shall consider the problem of concealing bunny on your person.

Rabbit Pockets:



The most logical place to conceal a rabbit is under the coat and in some curve of the body that will allow room for him. Above the hips the inward curve of the body gives the most room for this. For convenience in working, a special pocket is made to hold rabbit securely. Pocket may be made inside the coat, between coat and vest, or on the vest itself.

Figure 14.

Leon, who built such a reputation for the remarkable quantity of material he could produce from body loads, prefers to hang his loads on his vest rather than the coat so that his coat will hang better. He paid me a special visit once to ask me to tell my students to be sure to hang production loads on the body instead of the coat. Leon is one of the cleverest illusionists in vaudeville. He can produce anything from six glasses of water on a tray to a Christmas tree from under his coat with the aid of a cloth. A mere rabbit means nothing to Leon. He would feel more at home producing half a dozen rabbits.

Servais LeRoy is another famous magician who can produce a "bushel-basket full of rabbits" right out in the open stage, and maybe a few doves for good luck. The great Kellar used to say fondly of LeRoy, "He can pack a live woman into a two-inch space. I never expect to see a woman produced from a hat, but if I ever hear of its being done, I will know it was LeRoy who did it."

David Devant is another great magician whose name will go down in magical history for the beautiful manner in which he would pick up a lady's furpiece and suddenly extract a live, kicking bunny from it. The production of a rabbit was an art with Devant.

1 -- Rabbit Coat Pocket:

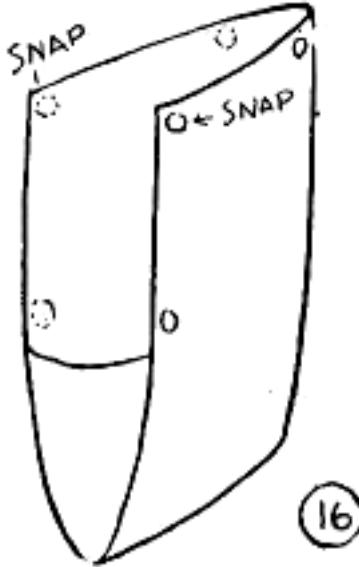
This is merely a large inside coat pocket. Have a good tailor make it for you. Opening is at outer edge of pocket



and should be slanted downward slightly so that rabbit can be got hold of easily. Place your rabbit or a bundle of cloth in the pocket so that tailor can fix coat to hang straight even with load in pocket.

Figure 15.

2 -- Bat Wing Pocket:



This type of pocket is the one which I prefer. It hangs suspended between coat and vest and is fastened on by snap fasteners. It can be removed and put in place at will.

Figure 16 shows construction of pocket, which you can make very easily out of black cloth. Fold cloth over and sew bottom edge together. Then sew piece of cloth across open side about one-third way up from bottom. Sew snap fasteners around top and down sides of pocket -- also sew three fasteners inside of coat and outside of vest in proper position so that pocket can be attached to them. The rabbit fits nicely in this pocket and can be taken out easily.

Figure 17.



For certain styles of working I use a bat wing pocket which opens all the way down the front and is held together by a snap fastener or two which can be jerked open quickly. The bat wing type of pocket is an excellent means for vanishing various articles as anything which is thrown between coat and vest is caught in the pocket.

3 -- Rabbit Vest Pocket:



This type of pocket is fastened to outside of vest. Opening is at outer edge and is held together by a snap fastener or button.

Figure 18.

I have taught you the principles of three good pockets and now you must experiment to find the type which answers your purposes best and which best conceals the rabbit on your build of body. Some carry the rabbit fairly high, others rather low. You must determine the best position for yourself.

SUGGESTIONS FOR HANDLING RABBIT:

A rabbit or other small animal will remain quiet in darkness, but becomes restless in the light. Your pocket, therefore, must provide as much darkness as possible, yet at the same time must be so constructed as to give the animal plenty of air. Cloth used in pockets and bags should not be too heavy. Usually the opening of pocket supplies enough air. Many times a rabbit will stick his nose out for air, so be sure to guard against any untimely appearance of the rabbit.

If animals have been carried in a case or small space for a period of time, try to give them a little exercise and freedom before using them. This also encourages their ex-

(43-9)

creting, thereby preventing soiled clothes. It is well to have bottom of pocket rubber lined for emergency.

* * * * *

AN UNEXPECTED RABBIT PRODUCTION

This is one of those effects in misdirection which lead an audience to expect a certain thing and produce something else. There is always a great element of surprise in these effects.

EFFECT:

Performer borrows a hat -- or uses his own -- and shows it to be empty. This is placed on an ordinary table, such as a card table. Magician states that he will cause hat to disappear. He holds up a cloth in front of hat for a moment, but when he removes it, hat is still in same position. Performer seems puzzled. He looks inside of hat, then reaches in and pulls out a rabbit.

PARAPHERNALIA:

- 1 -- A borrowed hat or one of your own.
- 2 -- A small rabbit that will fit into a hat.
- 3 -- An opaque cloth (audience must not be able to see through it), from thirty to thirty-six inches square, depending on length of your arm and convenience in holding. This cloth may be of Oriental design.
- 4 -- An undraped table -- a card table will do.
- 5 -- A rabbit pocket under left side of coat.

SECRET AND PATTERN:

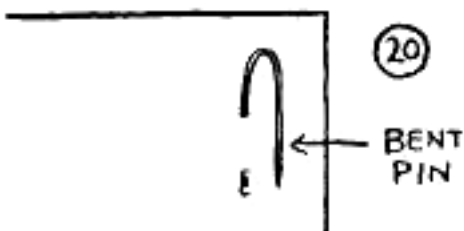
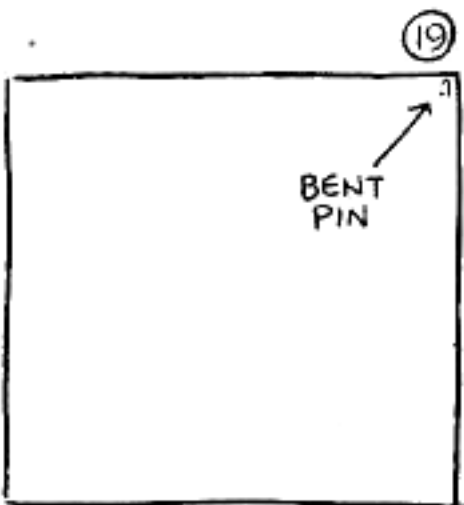
To Prepare:

In one corner of cloth run a pin and bend it over so as to form a hook.

Figures 19 and 20.

Place rabbit in special pocket under coat.

To Perform:



(21)

PIN



Borrow a hat or use one of your own. Show it empty, then place it on table. Pick up cloth, holding bent pin securely with right fingers and thumb. Pin is at rear.

Figure 21.

(43-10)

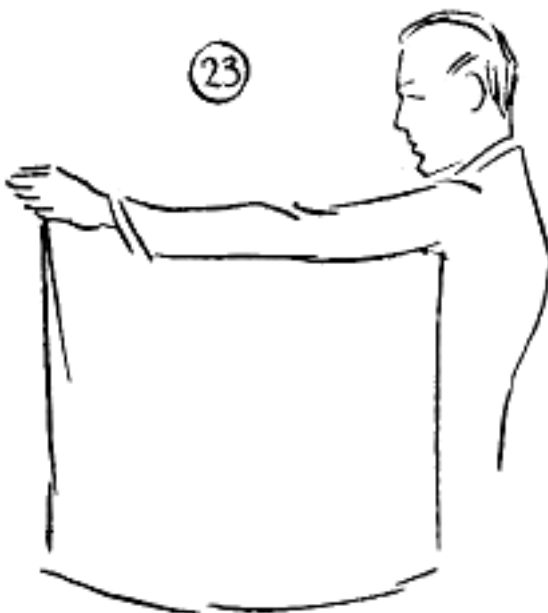
"There is an Oriental experiment in which the magician takes his turban or hat, places it on the ground, and then covering it for a moment or two, causes it to disappear. This always seemed to me an excellent way of eliminating check rooms. You could walk up to the check room, place your hat down, and just as the girl starts to pick it up, wave your magic cloth and said hat vanishes. If you do not mind, sir, I shall show you how it works with your hat. This will be the magic cloth."



Show cloth freely on both sides, holding it up between both hands. Left hand holds one corner and right hand holds pin corner with top edge of cloth drawn taut along left arm. Hook pin on to left shoulder of coat, but do not change position of right hand.

Figure 22.

"We shall cover the hat for a few moments."



Swing left arm around in front of table and hat, screening hat from audience.

Figure 23 shows you and cloth as audience sees you, Your back is almost turned to audience.

You can now release hold on cloth with right hand and have free use of right hand without audience seeing it. Audience is not aware that cloth is pinned up on left shoulder and believes that right hand continues to hold cloth up. Be sure that cloth hangs down close to coat and that no one can see between cloth and your body. Experience will teach you to swing cloth far enough to left.



With right hand reach into rabbit pocket and grasp rabbit by the ears. Pull him out and drop him into the hat out of sight. Be sure not to push arm out backwards so that audience will see it while performing these moves.

Figure 24.

Replace right hand on corner of cloth, unhook pin, and swing into position shown in Figure 22 again. Allow cloth to fall a little, bringing hands closer together as in Figure 21. Finally, hang cloth over left forearm.

Look at hat.

"Am I seeing things, or do you still see the hat there also? It is quite evident, sir, that your hat refuses to answer the dictates of Magic and intends to sit there."



Reach into hat, pick up rabbit by the ears and bring him out of the hat.

Figure 25.

"Well, no wonder, the engineer was sitting in it."

(43-11)

RAPID PRODUCTION OF RABBIT FROM HAT

EFFECT:

Performer shows hat empty, then suddenly extracts a rabbit from it.

SECRET:

To Prepare:

Place a small rabbit in rabbit pocket under left side of coat.

To Perform:



Show hat empty and place opening of hat against edge of coat at waistline or a little higher. Under cover of hat, reach into rabbit pocket with right hand, grasp rabbit by ears and pull him out of pocket behind hat.

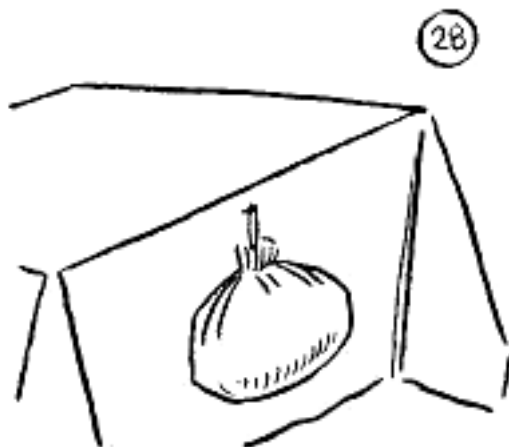
Begin to pull rabbit upward and as it reaches position shown in Figure 26, turn opening of hat upward. This brings back of rabbit into hat for a moment as you continue to pull him upward.



Figure 27.

The effect is that you pulled rabbit suddenly out of an empty hat. In reality, you pulled him up from behind hat and had only his hind legs in hat for a moment to show him coming out of hat. This takes coordination of movements and proves most effective when done right.

NOVEL PRODUCTION OF RABBIT FROM HAT



In this effect, rabbit is in a black bag, hanging on headless nail behind table. Nail slants upward so that bag will not slide off.

Figure 28.



Perform the Miser's Dream with a hat and a few coins. Stand at one side and toward rear of table in preparation for pouring out coins on table. Hold hat, opening upward, in right hand with fingers over edge of hat toward inside and thumb underneath brim. Swing hat around so that it is in position shown in Figure 29. Opening of hat is toward audience so that they can see coins in hat.



Pour coins out on table and swing right hand around so that it is at rear edge of table and hat is flat down on rear edge of table.

Figure 30.

(43-12)



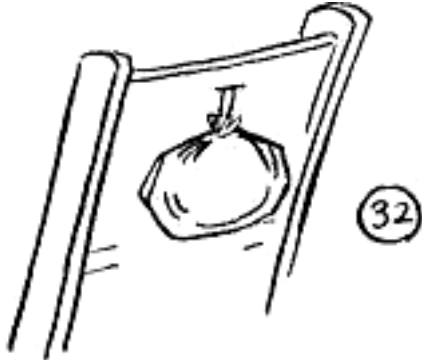
With left hand pick up several coins and drop them on table for MISDIRECTION. As you do this, grasp loop or rings on rabbit bag at rear of table with right fingers. Retain grasp on hat with thumb and forefinger.

Figure 31.

Raise rear edge of hat upward, getting rabbit bag inside of hat. Be sure to keep lower edge of brim down on table until bag is well concealed in hat. Then turn hat with opening upward, being careful that rabbit bag is not visible. Open bag quickly and produce rabbit.

* * * * *

EASY METHOD FOR RABBIT FROM HAT PRODUCTION



This is a good method for producing rabbit concealed in black bag hung on back of chair on headless nail. To get rabbit into hat from this arrangement depends on MISDIRECTION.

Figure 32.



Refer to Lesson 30 for method of loading silks into hat. Use this method for loading an object into hat, such as an Easter egg (a rubber, wooden, or celluloid egg, brightly colored). Bring this into hat and produce it by turning it out on to chair seat. You could also produce a few silks and turn them out on to chair.

As you reach down with left hand to pick up object or objects from chair seat, bring hat in right hand up against top of chair.

Figure 33.



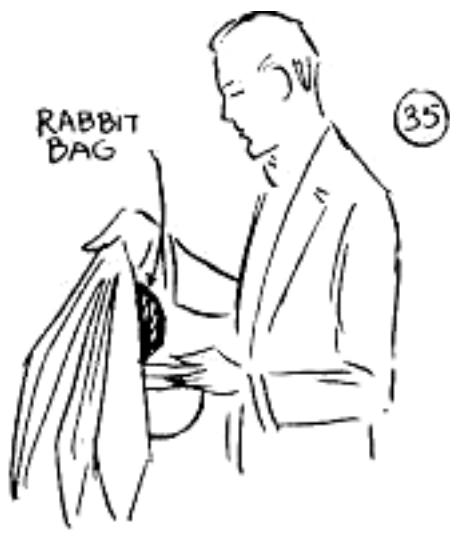
With right fingers grasp upper part of rabbit bag, slip it off nail, and lift it into hat. Raise hat to clear top of chair so that you can get bag in easily.

Figure 34.

Look at articles picked up from chair, then replace them. Look into hat and discover something. Open bag quickly and bring rabbit out.

* * * * *

SILKS AND THE RABBIT



In this method silks are produced from hat and are laid over back of chair. Silks are then picked up and with them, the rabbit bag. It is a good idea in this case to have bag same color as silks. Hold silks and bag over hat as in

Figure 35.

Allow bag to go inside of hat and push silks part way into hat on top of bag.

(43-13)

"There are more silks than there is room for in the hat. This silk came out of the hat, but there is too much to go back in again. Pardon me, there seems to be something in the bottom of the hat."

Take silks out and place them inside. Open rabbit bag and produce the bunny.

* * * * *

RABBIT PRODUCTION FROM PAPER RIBBON



This is a good finish for a silk and paper ribbon production from the Master Hat. Silks and coil of ribbon are first concealed in secret compartment of hat. Silks are produced and then the ribbon. The ribbon is unwound by means of the wand and is allowed to pile up on the floor.

Reach down and pick up ribbon, holding it in front of you with left hand. Be sure to conceal right hand.

Figure 36.



Reach into rabbit pocket at left side with right hand, bring out rabbit, getting him into the mass of paper ribbon. Pull him up out of the ribbon, allowing ribbon to fall to floor.

Figure 37.

* * * * *

RABBIT PRODUCTION FROM GENTLEMAN'S COAT

Audiences never seem to tire of seeing a magician reach up under a man's coat and extract a live, kicking rabbit. And children scream with delight at the effect.

This is a fine experiment, typical of the high-class magician, and it is not difficult to perform if you will study the moves closely and use good judgment in performing the effect. After you have the science of the production well in hand, practice to get grace and art into your movements so that there will be no bungling or hesitation in performance.

A rabbit may be loaded under a spectator's coat whether he is in the audience or on the stage. The same principles which apply to rabbit loading may be adapted to many other articles.

The big idea is to simplify your movements and screen them as well as possible. Much depends on the performer's MISDIRECTION.

The great Kellar used to lead up to his rabbit production from a spectator by first showing a red silk handkerchief and mysteriously vanishing it in his hands. He would then go down into the audience and choose a gentleman sitting in an aisle seat to his left. He would request the gentleman to stand up

and then proceeded to reach down gentleman's coat collar, pulling out the red silk along with a chain of other colored silks. Finally, he would reach down again and produce the rabbit. Kellar's idea was to start with a small parcel which could be loaded in easily, and then by misdirecting eyes of audience to the silks he could load in the rabbit.

Thurston uses a clever piece of misdirection. He has a little girl from audience stand up on seat behind spectator and pull gentleman's hair. Attention of audience is then misdirected to little girl and loading can be accomplished easily.

Some performers start by producing a lady's stocking, some baby clothes, or other objects, and then produce rabbit. A performer can walk right up to a spectator and pick a rabbit from his coat, but to lead up to it gradually is safest and permits of extra comedy.

SECRET AND PATTERN:

To Prepare:

Place a small rabbit in your rabbit pocket on left side.

Roll up a few silks, including a red one on top, into small ball and tuck up under left side of vest—this principle is known as VESTING, taught to you in a former lesson.

To Perform:

After you have performed an experiment in which a little girl from audience assisted you, pick up a silk handkerchief and cause it to vanish. You might pretend to place it in your pocket and have girl see your movements, only to show her that silk is still in your left hand. Then really vanish silk.

Take little girl down into audience and stop near a man sitting on the aisle to your left.

"Pardon me, sir, but I believe you are sitting on the red silk handkerchief."

You use this merely as a ruse to get gentleman to stand up.

"I thought sure that you were hiding the handkerchief. Ruth, maybe you can find it."

Have spectator sitting back of man standing get into aisle or move over so that Ruth can stand up in his chair.

"It may be, sir, that the silk walked up under your coat. Ruth, reach down the gentleman's coat collar and see whether you can find the silk."

As she reaches down, grasp gentleman's left coat lapel with your left hand and get him to face you. Come up close to him as though you want to assist girl in finding silk.



Figure 38 is a view from your right side.



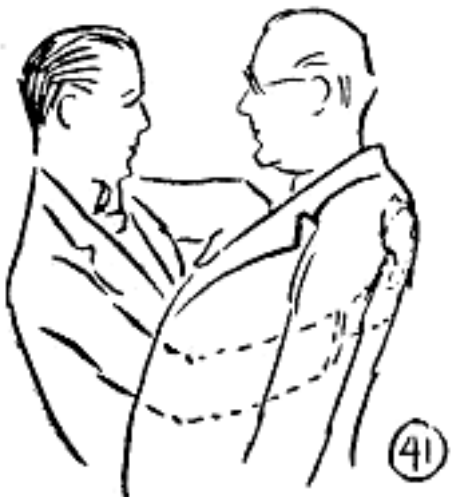
Raise your left arm up about shoulder height.

Figure 39 shows a view from your left side.



Reach under your vest with right hand and remove bundle of silks. You will find that your coat covers your movements on left side and spectator's coat covers them on right.

Figure 40.



Your right hand goes up under spectator's coat to back with bundle of silks. You can make this load with people all around you without fear of detection. Do it rather quickly without any hesitation.

Figure 41.



Push up end of red silk with right hand so that Ruth can find it, or else start pulling silk out of coat collar with left hand yourself.

Figure 42.

43



Let Ruth draw red silk out of spectator's coat collar. She will discover more silks and keep on pulling them out.

Figure 43.

"Keep pulling, Ruth, keep pulling."

As she pulls silks, step up close to gentleman again as though to help Ruth with silks. Have your body clone to his and a little to the left. Grasp his left coat lapel with your left hand as before.

(43-16)



Figure 44.



Grasp rabbit by ears with right hand and get him out of rabbit pocket under cover of your coat and that of spectator. Push rabbit up under gentleman's coat to the back.
Figure 45.



As silks are withdrawn, push rabbit up near coat collar to make coat bulge.
Figure 46.

"Look, Ruth, you forgot something."

Allow Ruth to reach down and grasp rabbit by the ears to bring him out, or you can take him out with your left hand.

Figures 47, 48, 49.



NOTE: In this method of loading, your coat screens your movements on left side from audience and gentleman's coat screens them on right side. Your coat and raised left arm screens movements from spectator you are working with.

You may produce silks and rabbit without aid of little girl by pulling silks out yourself and then loading in the rabbit while pretending to have missed something.

A guinea pig, because of its small size, is good for use in this production.

A CHICKEN PRODUCED FROM GENTLEMAN'S COAT

This is a good production in which stage loading is used with a chicken, a rabbit, a duck, or a small dog.

SECRET:

To Prepare:

Place chicken (or whatever animal you use) in bag and hang it on nail on front side of back of chair. Have chair with back toward audience.



To Perform:

Ask gentleman to come up to stage and have him stand with his back to back of chair. With your left hand lift bag from chair.

Figure 50.



For MISDIRECTION, have spectator hold some object or give him a few cards to count. You may count cards with him or move him around a little apparently to get him into proper position with the object he holds. Move him forward a little from chair and bring bag in left hand up behind his back.

Figure 51.



Have spectator reach into left trouser's pocket to see whether it is empty. As he does so, bring bag down and get thumb under bottom edge of his coat, lifting it up a little.

Figure 52.



With your right hand reach under right side of gentleman's coat and grasp bag in right hand, pulling it up on his back under coat.

Figure 53.



Turn him by pulling him toward you so that audience can see lump on his back. With right hand reach up under his coat to get hand under bag. With left hand reach down under coat collar.

Figure 54.



Open bag and let chicken come out part way.

Figure 55.

Keep left hand on chicken and with right hand get rid of bag by putting it into bat wing pocket on your left side. Get gentleman to move down toward audience to cover this move and then take chicken out as he goes down stage.

PRODUCTION OF BOTTLE OF MILK OR LIQUOR FROM
GENTLEMAN'S HIP POCKET

A bottle of milk with a nipple or a flat bottle, apparently containing liquor, can be produced from gentleman's coat. It always gets a laugh. A whiskey bottle full of tea has a good effect in prohibition times and a baby bottle full of milk is funny. This production is good for banquet work as well as stage work. It is also suitable for parlor and club work.

I teach you here my method for loading a bottle on a spectator so that I can apparently produce it from his hip pocket.

SECRET:



Carry a flat bottle of milk or tea in your left hip pocket.

Have spectator stand up and get him into position so that no one is behind him. Stand at his right and pull open his coat with your right hand.

Figure 56.



Under cover of his coat, remove bottle from your left hip pocket with left hand.

Figure 57.



Slip bottle up under spectator's coat at back toward right side.

Figure 58.



With right hand reach down behind spectator's right hip pocket and take bottle from left hand. Bring left hand up to his right coat lapel and hold coat open as you bring bottle out.

Figure 59.



Bring bottle out and show to spectator and audience. The effect is that you merely reach into gentleman's hip pocket and remove the bottle.

Figure 60.

* * * * *

CHANGING RABBIT TO BOX OF CANDY

When you produce a rabbit and there are children in the audience, some child usually wants the bunny. This is a nice way of handling the situation.

(43-19)

EFFECT:

After rabbit has been produced, performer has a little girl come up to stage to get it. He gives it to her, but then says that the rabbit might catch cold if exposed to the outside air, so it would be a good idea to wrap him up in a piece of paper. He wraps rabbit and gives parcel to girl. Rabbit squirms inside of paper and then suddenly becomes quiet. Magician places his ear against the bundle and says the rabbit's heart must have stopped beating. He unwraps parcel and discovers that rabbit has changed to box of candy, which he gives to the girl.

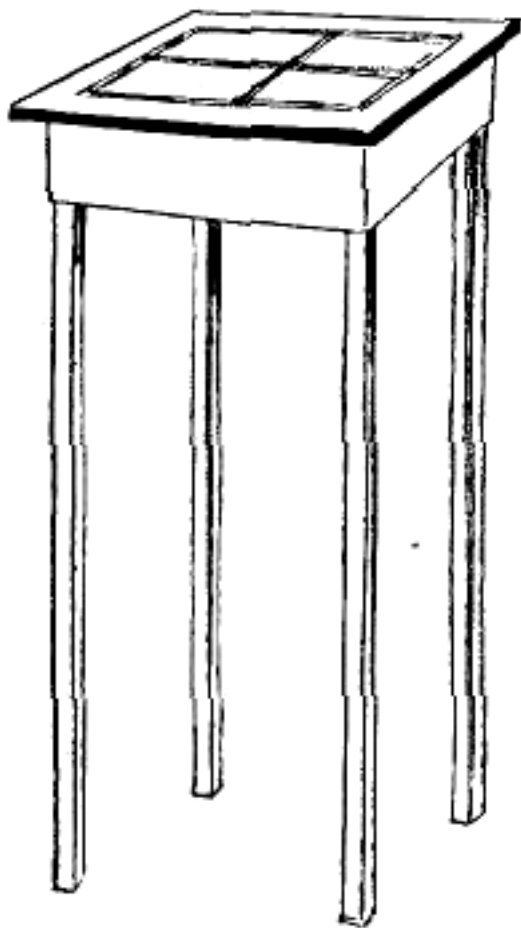
PARAPHERNALIA:

- 1 -- A pound box of candy.
- 2 -- A small rabbit or guinea pig.
- 3 -- A sheet of paper about two feet square.
- 4 -- A special Brunel White Changing Table, commonly known as the B. W. Changing Table.

Top of this table is so arranged as to make it easy to vanish one object and produce another so that the objects apparently change.

SECRET AND PATTERN:

61



To Prepare:

To construct B. W. Table:

Figure 61 shows a rough sketch of this table. It may be lacquered in black and decorated with Mandarin red and gold. It is necessary to build a changing trap for the top. You will have no difficulty if you will study the illustrations and explanation carefully.

62



Figure 62 shows a cross section of top of table when flap is raised.

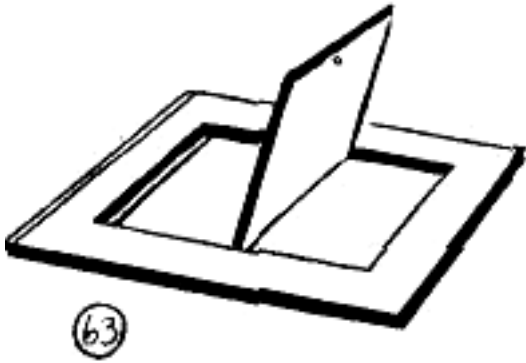
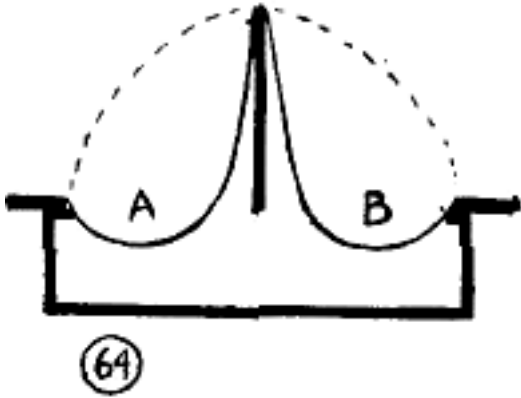


Figure 63 is a diagram of top, showing arrangement of frame with flap in the middle.

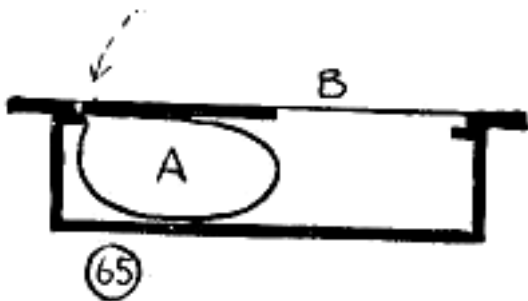
After you have made box for table top, place open frame over top edges of box, and attach a flap across middle of frame by hinges—flap should be half the size of the opening in frame. Tack a piece of cloth to one end of frame at inner edge of opening. Turn flap down toward opposite end, stretch cloth tight across opening in frame and tack it to top of flap. With flap in this position, cloth forms table top. Now turn flap over to opposite end of frame, letting cloth go inside box of table top and stretch cloth over other side of flap to end of opening in frame and tack.



You now have this arrangement: Flap in middle of open frame on top of box which forms table top. On each side of flap cloth extends to each edge of opening in frame, making sides A and B.

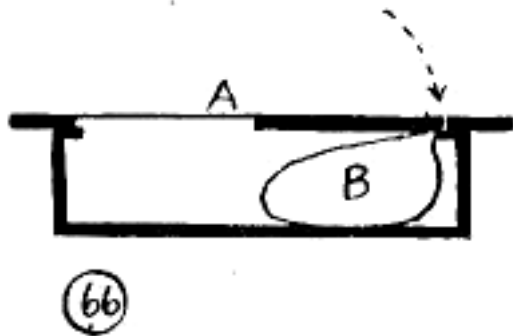
Figure 64.

(43-20)

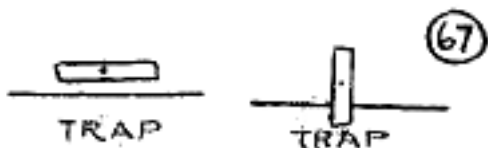


When flap is closed down to side A, cloth A goes down into box of table top and is concealed, and cloth B is stretched tight over top of table. When flap is closed down to side B, cloth B goes down and cloth A forms the table top.

Figures 65 and 66 are cross section views showing construction.

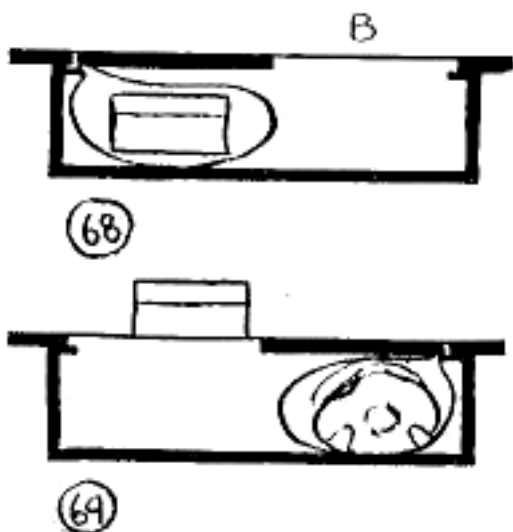


Decorate sides A and B alike with just a border around the edges and a line across each way as shown in Figure 61.



On solid part of table top at both ends place a small catch which can be turned over flap to hold it when you place rabbit under it.

Figure 67.



Figures 68 and 69 show diagrams of operation of Changing Table in this effect. If a box of candy is placed in compartment A and flap closed down on it, and a rabbit is placed on top of side B, the weight of rabbit will cause B to go down, raising flap up. Performer brings flap down over side B, concealing rabbit and the box of candy is brought up to top of table.

Make table legs to screw on to top.

After table is built, prepare for experiment by placing box of candy in compartment A with flap down over it. Fold piece of paper and have it lying on table.

To Perform:

After you have produced rabbit, ask children in audience who would like to have rabbit. Immediately hands go up and there are many "I's". Select a small girl and have her come up to stage. Ask her name—assume that it is Mary.

"So, Mary, you think you would like to have a rabbit. Of course, this is a magic rabbit, and you must be very careful with a magic rabbit. What would you feed him?"

Here is an opportunity for a bit of talk on feeding problems.

"He likes carrots and greens and whole wheat bread. You like those things yourself, don't you, Mary? They keep rabbits and boys and girls healthy. What will you name the rabbit? I call him Whiskers. Shall I tell you how he got his name? Well, one day I set a pail of water at the foot of the basement stairs. The rabbit came scurrying down the stairs and he didn't see the water, so he tumbled in and got all wet. Now rabbits are something like small boys—they hate water. So I pulled him out of the water all dripping wet. And from that day to this I have called him Whiskers."

There is no sense to this explanation of the name, but that's what makes it funny. Give rabbit to girl.

"Now take good care of him and give him a good pillow to sleep on."

(43-21)

Guide her down to edge of stage.

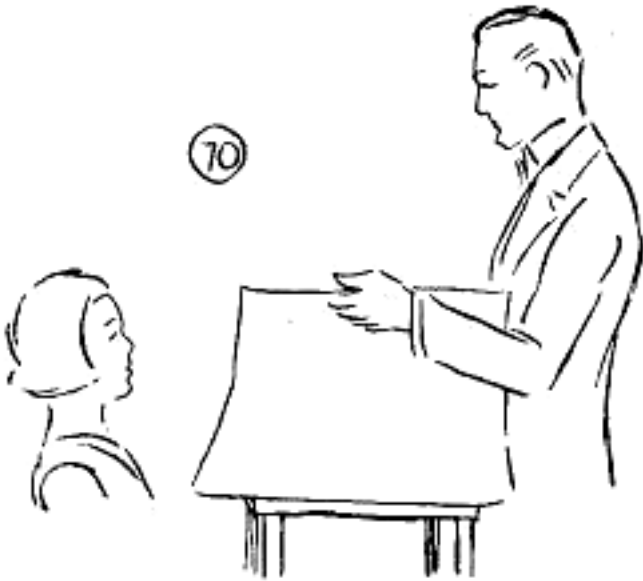
"Oh, just a minute. I almost forgot. You didn't come prepared to take the rabbit home, so we had better wrap him up to keep his feet warm."

Bring her back to right side of table. Pick up piece of paper and unfold it. Audience must see that there is nothing on table and nothing in paper.

"Now, Mary, come right up close to the table and help me wrap him up for you."

Hold top edge of paper in left hand and take rabbit in right.

"Come right up here in front."



Bring paper up in front of table and place rabbit behind. Have girl in front and to side a little but be sure she cannot see change behind paper. Place rabbit on cloth part of table top. His weight will raise flap. Grasp edge of it and bring it down over rabbit. This pushes him into compartment B and brings box of candy to top of table. Close catch down over flap.

Figure 70.

Bring box of candy up to center of paper and wrap paper around it. You must work quickly here to give impression that you really wrapped up rabbit. Hesitation in making the change will cause suspicion on part of audience.



Bring parcel away from table. Paper is wrapped loosely so edges of box cannot be seen and ends are twisted. Move your hands about to give impression that rabbit is squirming inside.

Figure 71.

Place parcel in girl's arms. Push down on right end of paper and cause parcel to jump up, then push on left end and right again. Apparently, rabbit is trying to get out.

Figure 72.



Suddenly allow parcel to remain quiet.

"Did you notice anything, Mary? He is quiet all of a sudden."

Place ear against parcel.

"I think his heart has stopped beating or he has stopped breathing. Let us see."

Unwrap paper, exposing box of candy.

"Why the rabbit's gone! He has changed into a box of candy --a box of (name brand)--chocolates. You never can tell about

a magic rabbit named Whiskers. He is here one minute and gone the next."

Hand box of chocolates to girl.

Figure 73.

"Take these nice chocolates home with you, Mary, and you can tell your friends that the magic rabbit left them for you."

NOTE: If convenient, you may produce another rabbit for girl by reaching down some spectator's coat collar and extracting it from there. Usually, however, the magician must keep his rabbit for the next show as they are not always plentiful.

The B. W. Table may be used for many changes, such as changing a white rabbit to a black one, a rabbit to a bouquet, etc.

Another style base which may be used with the B. W. Table is one of nickel, which folds up. This is the same base which we supply with our Brown Beauty Table (this will be described later.) It is light and rigid and folds up small. We can supply you with this base.

Figure 74.

* * * * *

SAUSAGES FROM BOY'S COAT

This is a comedy stunt easy to perform. It may be done with a small boy or a grownup.

The sausages are imitation, made of brown cloth filled with a coiled spring and sewed together to form a link.

Figures 75 and 76.

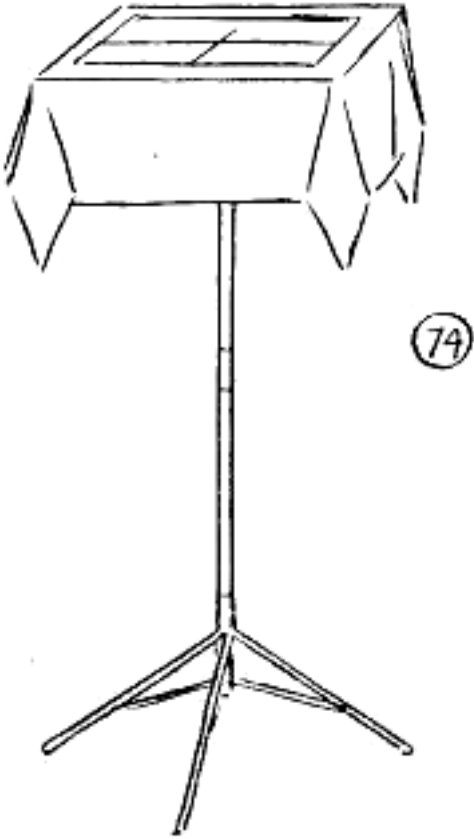
Links can be compressed into small bundle and held together by rubber band.

Figure 77.

This bundle can be palmed easily and concealed in right hand.

Figure 78.

To produce sausages, merely reach up under boy's coat and release rubber band. This causes sausages to expand so that you can pull them out.



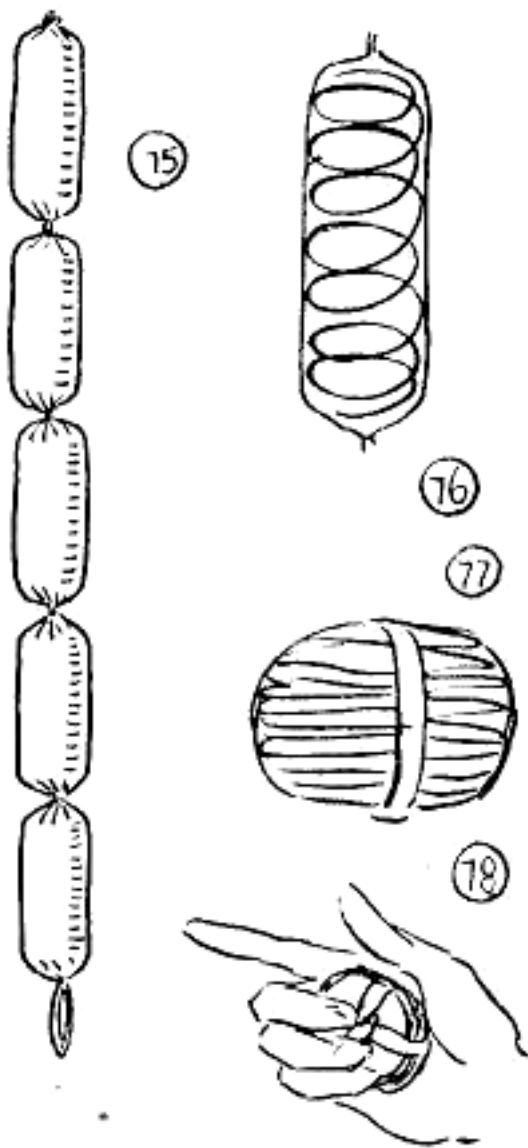


Figure 79.

NOTE: We can supply you with this special type of collapsible sausages. See price list.

(43-23)



GENERAL HAT PRODUCTIONS

The principles which I taught you in this lesson for performing productions from a hat may be used for producing a variety of objects. For regular hat production work, collapsible objects are in favor because they can be folded into small space and then expand when produced. Solid articles, however, also play their part.

Articles which are apparently solid are really hollow for production work and are arranged so that loads can be carried in them. For instance, an alarm clock can have the works removed and an opening made in the back into which many silks can be loaded. Clock and silks are loaded into hat, then silks are produced from the clock and clock is finally produced from hat.

A can of corn or peaches makes an interesting production. Take a can, cut off bottom and empty contents. Clean can well and dry it. On one side of can have a small ring soldered so that can may be hung on back of chair or table. Can may be loaded with baby clothes, silks, etc. First these are produced and then the can. Be careful in showing can not to expose open bottom.

A handwritten signature in cursive script that reads "Harlan Tarbell". The signature is written in black ink on a white background.

TARBELL SYSTEM, INCORPORATED, Chicago.

* * * * *

LESSON 44

An interesting array of Magic, including the famous wine and water effect in which wine, water, and milk are poured from a pitcher of water and then wine and milk combine to form water again. Also the wandering bottle experiment, a peculiar Three Card Monte effect with a bottle, the mysterious transposition of smoke, confetti and ribbon effect, and several cooking experiments.

(43-24)

LESSON 44

CHEMICAL AND MECHANICAL MAGIC

This lesson gives you some very interesting chemical and mechanical magic. You learn the basic principles involved in these two types of magic so that you can use them to good advantage in your programs.

These eight excellent effects are taught to you:

- 1 - A Novel Transmission of Smoke
- 2 - Wine and Water
- 3 - The Wandering Glass and Bottle
- 4 - Comedy Version of Wandering Glass and Bottle
- 5 - Bottle, Bottle, Where's the Bottle?
- 6 - A Magical Transformation
- 7 - A Cooking Lesson
- 8 - The Welsh Rarebit

The material for the chemical magic can be purchased at almost any drug store. The special apparatus used for the mechanical magic is standard equipment and we can furnish you with it when you need it.

* * * * *

A NOVEL TRANSMISSION OF SMOKE

We have Ellis Stanyon of England to thank for this fine experiment with smoke.

EFFECT:

Magician calls attention to a glass pitcher containing clear water. He then pours some of the liquid into a glass tumbler. He stands at a distance from glass and blows smoke from a lighted cigarette toward it. The water in the glass gradually becomes milky, presumably because the smoke travels across the stage and gets into it.

PARAPHERNALIA:

- 1 -- Dilute solution of hydrochloric acid -- one part acid to ten parts water.
- 2 -- Saturated solution of hypo-sulphite of soda, commonly known as hypo.
- 3 -- A small glass pitcher.
- 4 -- A glass tumbler.
- 5 -- A silk handkerchief or cloth to place in front of glass tumbler.
- 6 -- Cigarette and matches.

SECRET AND PATTERN:

To Prepare:

Take the solution of hydrochloric acid and put about three parts of an ounce in the glass tumbler. Place glass on table.

①



In front of it place silk handkerchief or a book or some other object to cover lower part of glass so that it will look empty.

Figure 1 shows a side view of arrangement of glass and handkerchief.

Take the hypo-sulphite of soda or HYPO and make a saturated solution of it in cold water. Then dilute this solution by adding an equal quantity of water again. Pour this solution into the glass pitcher. Place pitcher on table.

When these two solutions are poured together in the experiment, the water becomes milky. When the solution is strong the change takes place instantly. As the solution is weakened, the change takes place more slowly. Experimenting will teach you just how strong to make solution for this effect so that you will have time to go some distance away and blow smoke at glass before it changes to milky color.

The milky effect in the water remains for some time and thus gives an excellent imitation of milk for use in a variety of magical effects.

To Perform:

Pick up glass with left hand. Be sure to screen fluid in glass with fingers of hand. Pick up pitcher in right hand.

"It is customary with lecturers and Fourth of July orators to stop and pour themselves a glass of water to quench their blazing vocal cords."

Pour hypo solution from pitcher to fill glass about three-fourths full. Replace pitcher on table and place glass, presumably containing water, in full view of audience. If desired, glass may be placed by itself on small stand.

"Being neither lecturer nor orator, I can only use the glass of water for scientific experiments."

②



Go some distance away from glass and light a cigarette. Puff on cigarette and blow smoke towards glass. Repeat.

Figure 2.

"For instance, I can show you the modern way of condensing smoke so that it can be sold in bottles. We used to smoke hams in a smoke-house, but now we just paint them with liquid smoke."

Water gets milky gradually as you blow smoke at it. The chemicals, of course, accomplish the effect, but it appears that the smoke you blow at glass gets into water and makes it smoky.

"Water has a natural affinity for smoke and like a magnet drawing steel draws smoke unto itself, condensing it and coloring the water. A friend once had the idea of drying snow and selling it for salt. Why not condense smoke and sell it for milk?"

* * * * *

WINE AND WATER

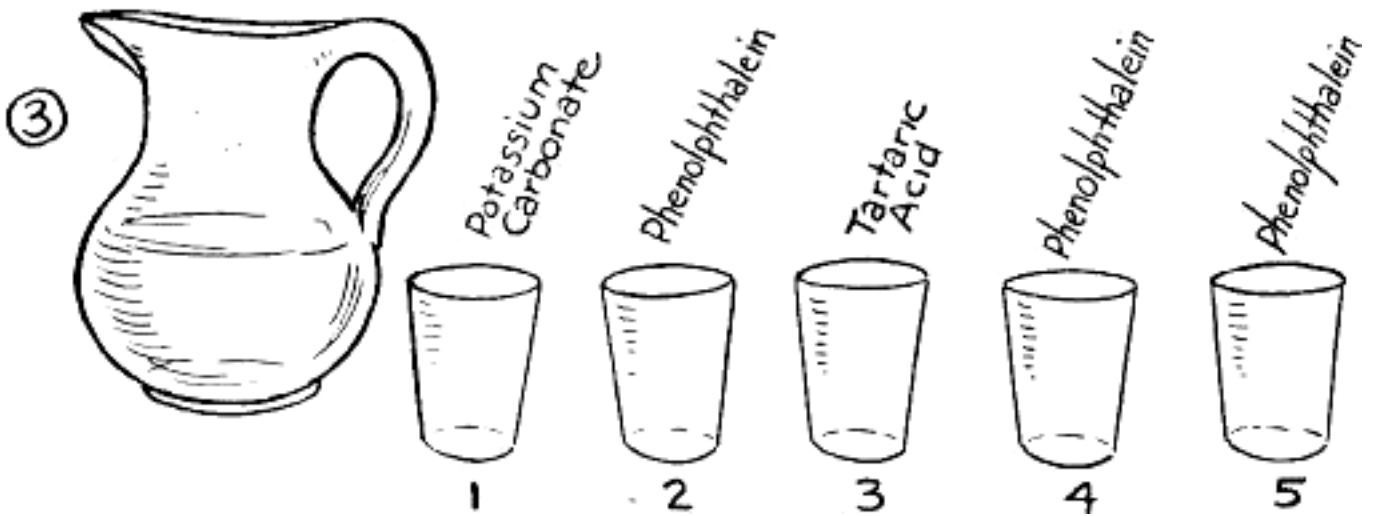
How popular this effect has been on many magician's programs! And especially since Prohibition, it has been excellent because of the comedy which can be employed in it. This is a chemical experiment and many different chemicals have been used to get the effect. I am going to teach you to perform it in a simple, safe manner without strong acids and alkalis.

EFFECT:

Performer shows a glass pitcher half full of water, and five empty glasses. Into the first glass he pours water, into the second red wine, into the third gin, and into the fourth red wine. Each glass is filled about half full. He pours the contents of the first glass into the second and back into the first, giving wine in both. The third and fourth glasses are mixed, giving water in both. The first and second glasses of wine are poured back into the pitcher, making wine in the pitcher. The third and fourth glasses, containing water, are poured back into the pitcher, resulting in clear water as in the beginning. Magician then pours water from the pitcher into the fifth glass, changing it to milk.

PARAPHERNALIA:

- 1 -- A strong solution of phenolphthalein. Fill a bottle about one-fifth full of powdered phenolphthalein and fill bottle with alcohol.
 - 2 -- Tartaric acid solution. Fill a bottle half full of powdered tartaric acid and fill bottle with water.
 - 3 -- Potassium carbonate solution. Fill bottle half full of potassium carbonate or sodium carbonate and fill bottle with water.
- Any druggist will sell you the above ingredients or make the solutions for you. To begin with use a six-ounce bottle of the phenolphthalein solution and six-ounce bottles of the others. The amounts can be increased according to your needs. SHAKE EACH SOLUTION WELL BEFORE USING.
- 4 -- A glass pitcher with more than enough water in it to fill four glasses about two-thirds full.
 - 5 -- Five glass tumblers.



To Prepare:

Arrange glasses in a row as in Figure 3. Into glass No. 1, place half teaspoonful of the potassium carbonate solution; into glass No. 2 a few drops of the phenolphthalein solution; into glass No. 3 a teaspoonful of the tartaric acid solution; into glass No. 4 a few drops of the phenolphthalein solution; and into glass No. 5 a teaspoonful or so of the phenolphthalein solution.

YOU WILL HAVE TO EXPERIMENT TO GET THE PROPER PROPORTIONS to use of these solutions, but once you know the principles on which the effect is based, you will have no difficulty in working it.

Phenolphthalein is used in medical laboratory tests. An alkaline solution turns it red and acid solution turns it colorless again. The color will vary from light pink to deep red, depending on the strength of the phenolphthalein and alkaline solutions.

Potassium or sodium carbonate, being alkaline, turns the phenolphthalein solution red; the tartaric acid, being acid, bleaches it out again.

Some performers in emergency use a little ammonia as the alkali and vinegar as the acid. Some prefer strong agents like caustic soda and hydrochloric acid as only a small amount is required. For all around use, however, potassium or sodium carbonate and tartaric acid are the best for with them there is no danger of accidents.

The milk effect is produced in the fifth glass by pouring water on the strong phenolphthalein solution. You must experiment here to learn just how much of the phenolphthalein solution to use in glass to produce about two-thirds of a glass of milk by pouring water over it.

To Perform:

Have pitcher of water and five prepared glasses on table. Glasses may be in a row or fifth glass may be in rear until needed at finish of effect.

Pick up pitcher of water with right hand and glass No. 1 with left hand.

"Seeing as how we have such a nice comfortable gathering here, it might be a good idea if we had a little drink between ourselves. The gentleman there, I believe would like a glass of water."

Pour water into glass, filling it about two-thirds.

"Oh, pardon me, you seldom drink water."

Pour the glass of water back into pitcher again. This now gives you a solution of potassium carbonate in the pitcher.

"How about a little gin?"

Pour water back into glass No. 1 and place on table in full view.

Pick up glass No. 2 and pour potassium carbonate solution from pitcher into it, filling it about two-thirds full. This gives a bright red solution in glass.

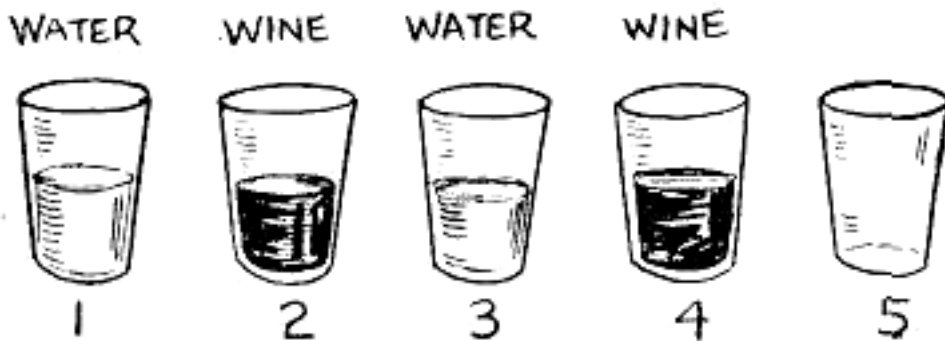
"Or how about a little 'vin rouge' or red wine?"

If solution should happen to be too weak and you get a pink color, you can call it strawberry soda or Russian wine or whatever seems suitable for the occasion.

"All right, sir, a little gin for the gentleman over here."

Pour water from pitcher into glass No. 3. There is no chemical reaction here and fluid in this glass remains colorless like gin.

"And a bit of rare wine for the gentleman here."



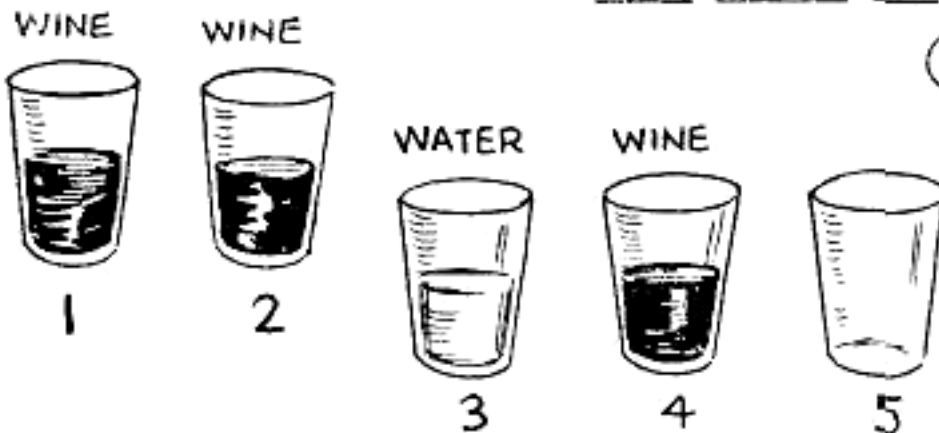
④

Pour water into glass No. 4 and the potassium carbonate in it will produce a red liquid in this glass.

Figure 4.

Set pitcher on table and pick up glasses No. 1 and 2.

"What's that? You would rather have wine than gin? All the same to me."



⑤

Mix contents of the two glasses together, causing both to contain red liquid. You now have arrangement of liquids in glasses as shown in Figure 5.

"Or, better yet, why not have a whole pitcher of this rare vintage?"

Pour both glasses No. 1 and 2 into pitcher. Contents of pitcher are now colored red.

Pick up glasses No. 3 and 4.

"A glass of wine and a glass of gin. You want two gins instead."

Pour liquids back and fourth in these two glasses. The chemical action here changes the red solution to a colorless one like water or gin. Finish with half of the liquid in each glass.

(44-5)

"Two gins."

Look toward rear of hall.

"Pardon me, the manager is trying to tip me off that the prohibition officers are just coming in."

Pour the two glasses of clear liquid back into pitcher, which causes contents of pitcher to turn colorless again.

"I am pleased to offer you, my friends, a nice drink of water."

Pick up glass No. 5 in left hand and pour colorless liquid from pitcher into it.

"Or, how about a little milk?"

Pour solution from pitcher into fifth glass and effect of milk is produced.

A comedy touch may be added here, if desired, by picking up a sixth glass and pouring out a good imitation of a glass of beer. Have a cardboard sign to place in front of it, on which is lettered - 1/10 of One Per Cent.

To produce the beer have a little liquid soap (made by boiling soap bark) and some iodine in bottom of glass. When water from pitcher is poured over it, the iodine gives the color of beer and the soap gives the foam. Anilin dye may be used instead of iodine, or even some dark cake extract. To get a good bubble, seidlitz powders may be placed in bottom of glass instead of soap. Have bottom of glass screened by some object so that audience cannot see powders. When water is poured into glass, the powders will foam and bubble and the iodine gives the effect of beer.

* * * * *

MECHANICAL MAGIC

The rest of this lesson will be given over to effects performed with special apparatus. Throughout the course, I have kept away as much as possible from mechanical apparatus. I not only wanted to cut down your expense, but also to give you a magical training with simple objects.

Now I think it is time that you learn some of these mechanical effects. They have played a very important part in the magician's program and I want you to be fully versed in them. From time to time you can add the various pieces of apparatus which they require and use the effects on your programs. They are old magical classics.

The Bran Vase, Dove Pan, and Rabbit Pan are useful especially when there are children in your audience, although they are also interesting for grownups. You will find that the introduction of a piece of apparatus of this nature here and there in an evening's performance is welcomed.

Be careful of the apparatus you buy. I have spent thousands of dollars for material which I could not use and that's why I warn you to beware and to buy only the very best. You can waste a great deal of money if you do not know how and what to buy. In selecting apparatus for the effects in this course, I have chosen only PRACTICAL THINGS which have stood the test of time and which will serve you for various different occasions. The apparatus we supply to students is the same kind which I use personally and it can be depended on. It is easy to operate and will hold up under use. The apparatus to be used for the following effects is not expensive, considering its workmanship and wearing qualities. It is excellent value for your money.

I can supply you with this apparatus now, if you desire, or from time to time as you need it and want it.

THE WANDERING GLASS AND BOTTLE

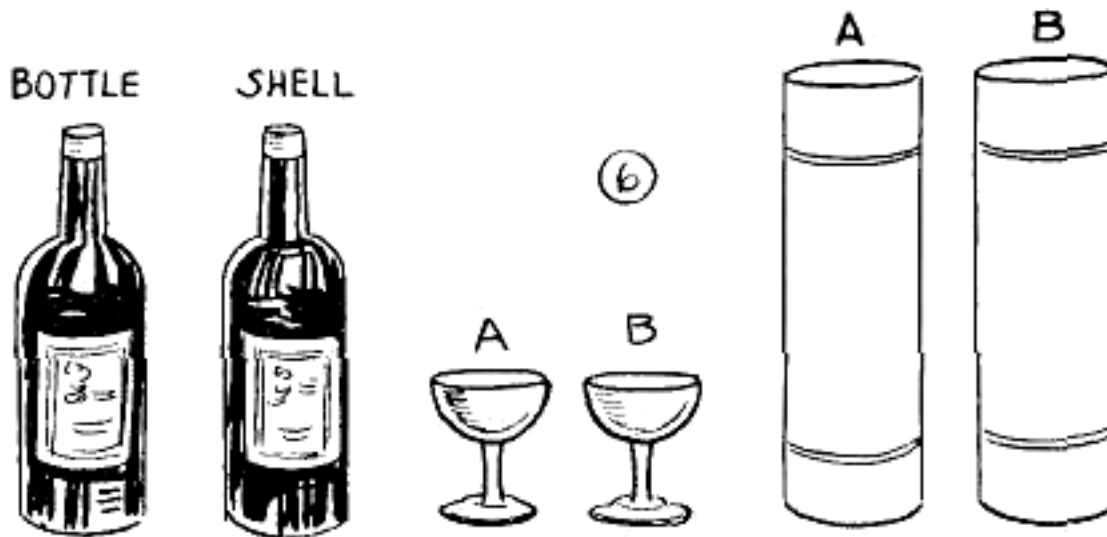
How well I remember my mystification when I was a boy to see the magician cause a bottle and a glass of wine to change places at will. This effect is just as interesting to me now as it was then. It is familiarly known as The Passe-Passe Bottle and Glass Effect.

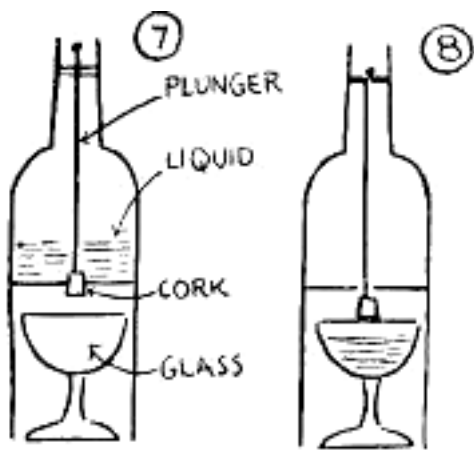
EFFECT:

Performer shows a bottle and glass, also two empty cylinders. These cylinders are just large enough to fit down over the bottle or the glass. Magician pours out a glass of wine from bottle and places bottle and glass some distance apart. He places one cylinder over the bottle and the other over the glass. Upon command, bottle and glass change places. Bottle and glass change about as often as commanded by performer and covers are shown freely at any time.

PARAPHERNALIA:

1 -- A special Passe-Passe Bottle and Glass Outfit. This consists of a mechanical bottle, a shell which fits over the bottle and looks like a bottle, two goblets, and two cylindrical covers. The covers are so made that one fits over the other to facilitate packing. Figure 6 shows the complete outfit.





The bottle is so prepared that it has two compartments--one above to hold liquid and one below to conceal a glass. In bottom of upper compartment there is a hole, into which is fitted a rubber cork attached to a plunger which extends almost to top of bottle. When cork is in place liquid is kept in upper compartment. When plunger is pushed downward and cork is dislodged, contents of upper compartment flow down into glass in lower compartment. Bottle has no bottom.

Figures 7 and 8 show mechanical arrangement inside of bottle.

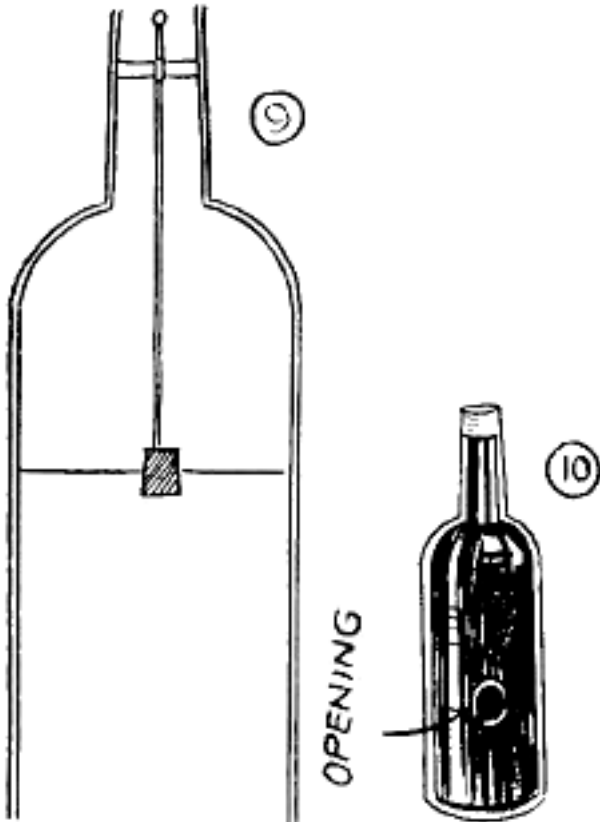


Figure 9 shows cross-section of bottle with shell over it.

At back of bottle and of shell is a hole through which second finger of right hand can be placed to grip glass inside. Thus when bottle is picked up, glass is carried along also.

Figure 10.



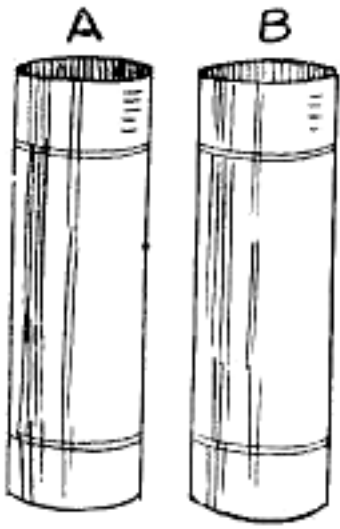
Figure 11 shows hand on bottle with second finger inside of opening in shell and bottle to hold concealed glass, while performer pours liquid from upper compartment of bottle into a glass.

From audience's standpoint, the bottle is just an ordinary bottle with some liquid in it. To the performer, it is an ingenious mechanical contrivance.

SECRET AND PATTERN:

To Prepare:

Place enough red-colored water or diluted grape juice in upper compartment of bottle to fill two glasses about three-quarters full. Experiment to get the right amount of liquid so that the amount which will flow down into concealed glass will be the same as that poured out into glass seen by audience.



12

Have the two covers, bottle with liquid in upper compartment and glass concealed in lower compartment with shell over bottle, and other glass -- all on table as shown in Figure 12.



If desired, bottle and glass can be brought in on a tray with the covers. This arrangement makes it easy for you to dispose of bottle and glass at finish of experiment.

(44-8)

To Perform:

Start experiment with this patter:

"It is said that this experiment originated with a monk in one of the old monasteries of France. The monks have been noted for their fine wines. The experiment may have been used by this monk to lead his brethren into believing that they were seeing things. Anyway, according to the story, the monk used a bottle and a glass of wine."

Pick up bottle and shell with right hand. Insert second finger through hole to grip glass inside of bottle. Pour liquid, supposedly wine, out of bottle into glass on table, filling it about three-fourths full.

"This, by the way, is a rare old vintage of the year 1362. I was there when they bottled it."

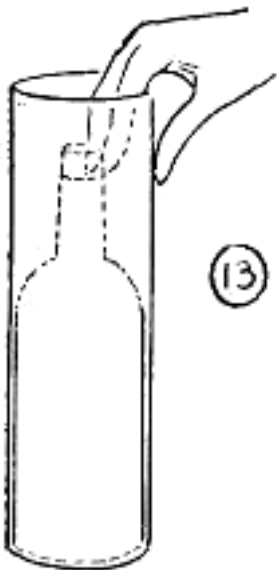
Place glass at left side of table and bottle at right on tray. Be sure to keep hole in shell to the rear.

Pick up the two covers.

"These two covers may be likened unto any other covers with the exception, perhaps, that these have a hole running through them and out both ends."

Show covers freely so that all can see they are nothing but cylinders with nothing concealed inside.

"The covers are just large enough to fit comfortably over the bottle."



Place the larger cover B over the bottle and shell to demonstrate the way it fits. When cover is over bottle, push down plunger in bottle with your right second finger so that liquid will flow from upper compartment of bottle into concealed glass underneath.

Figure 13.

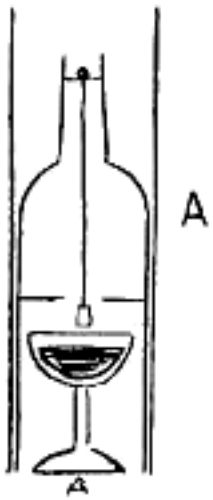
Now remove cover, and as you do so, press second finger against top inside edge of shell and remove shell inside of cover.

Audience sees bottle on table and is not aware of any change in it. They believe you merely covered bottle to show size of cover.

"This other cover, likewise, fits comfortably over the bottle."

Place other cover A over bottle with left hand. Lift it up a little to expose bottle again, then set it down to cover bottle fully.

"The covers fit over the glass of wine also."



(14)



Place cover B with shell inside over glass of wine. You now have this arrangement: Cover A over bottle with concealed glass now filled with liquid due to release of cork in upper compartment. Cover B with concealed shell over glass of wine which audience saw.

Figure 14.

"We have the bottle over on this side"

Lift cover A again, showing bottle, and replace.

"And the glass of wine over there."

Lift cover B and shell with it, showing glass of wine.

"The mystery of this old monk's experiment lies in making the bottle leave the tube here and go over to the tube there while the glass leaves the tube here and takes the place of the bottle there -- in other words, they change places."

Point to the covers as you explain this.

"So I carry the bottle from here and place it over there."

Pretend to carry invisible bottle from cover A to cover B. Pretend to hold bottle in palm of right hand with left hand at top of it.

"And I take the glass from here over there."

Make appropriate movements, as if carrying invisible glass from one cover to the other. Look into tops of covers, then at audience.

"That's done. The bottle and glass have changed places."

Do not lift cover, merely tell this to audience. Immediately they get suspicious and want visible proof.

"It is really a difficult thing to do. Imagine making a bottle of wine and a glass of the same wine change places without your seeing them go. However, the most difficult problem is to cause the bottle and glass to change places again and go back under the covers as they were originally."

Audience is amused by this as it would require no change at all to accomplish this. Bottle and glass need never leave their original locations.

Lift up covers again, showing bottle and glass.

"And, just as I said, the bottle is back here and the glass has returned there."

Bow slightly. Audience takes this as a

joke and does not consider it as a
trick.

Now cover bottle and glass again.

(44-10)

"It is quite evident that there is undue snickering going around at my expense. This is due to your astonishment at being so completely baffled. A great many of you would like to see me perform it again. Now, instead of starting with the bottle over there, suppose we start with the glass over there."

Point to cover A, then remove it. As you do so, get fingers of right hand inside of upper rim of cover and thumb outside. Grasp bottle so that you can carry it away concealed inside of cover. When you remove cover and bottle, glass of wine is left on table. To audience it appears that this is glass of wine which they have seen before.

"And the bottle over here."



Lift off cover B with left hand, leaving shell over glass of wine which audience saw you cover. To spectators it appears that bottle and glass of wine have actually changed places.

Figure 15.

Show covers freely, being a little careful of bottle concealed.

"Now we are ready to start. First, cover the bottle here."

Cover bottle shell again.

"And the glass of wine there."

Place cover A with bottle over glass again.

"Of course, I could have started with the bottle over there."

Lift cover A, exposing bottle.

"And the glass there."

Lift cover B with shell, showing glass. Cover bottle and glass again.

"Or vice versa."

Lift covers again, performing the proper moves to change bottle and glass again. Show them as in Figure 15. Cover bottle and glass again.

"If I had said versa vice."

Remove covers, showing bottle and glass changed again.

"Things would have been different."

Cover bottle and glass again, but this time, EXCHANGE COVERS so that B with shell covers bottle and empty cover A covers glass.

"So, my dear sir, if you should see – a glass of wine....."

Lift cover B with bottle and shell inside, showing the glass. Replace cover B.

"Climb up a tree."

Lift cover A, showing another glass of wine.

"You've been drinking, sir."

Now lift cover B again, revealing bottle.

"You've been drinking – and thus, we have a bottle, a glass, and our two empty covers."

Place glass on tray with bottle and also covers so they may be removed and set up again for another experiment.

* * * * *

COMEDY VERSION OF WANDERING GLASS AND BOTTLE

This is an excellent comedy effect if you have an assistant to help you.

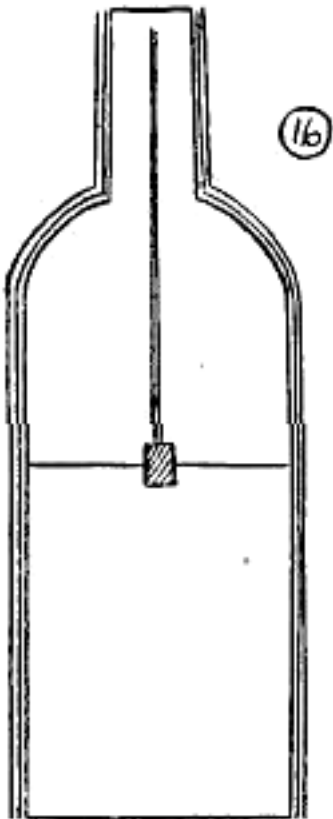
EFFECT:

As described above. During the passing of bottle and glass, assistant looks on with interest. Finally, while performer is busy talking to audience, assistant steals the bottle out of cover at performer's right and, placing it under his arm, sits down in a chair to enjoy the magician's discomfiture about to come. However, when magician lifts the cover, bottle is still there and assistant is surprised to find that it has vanished from under his arm. Performer continues as though nothing had happened.

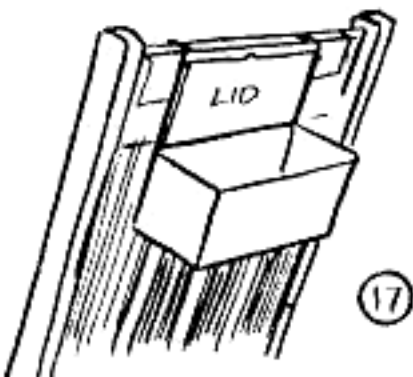
PARAPHERNALIA:

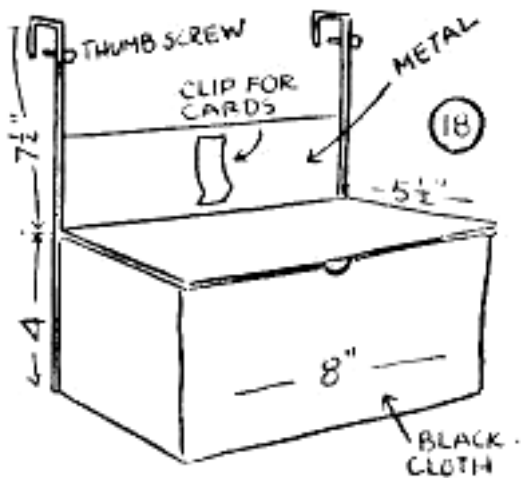
1 -- The outfit is the same as the regular Passe-Passe Bottle and Glass except that there are two shells used instead of one. The two shells fit over the bottle as shown in Figure 16.

We can furnish you with this outfit, but in ordering be sure to state that you want the COMEDY VERSION.



2 -- A special Servante to attach behind a chair. This Servante is very handy and it is durable. It can be attached to back of chair easily as shown in Figure 17. Two metal bars fit over top of chair to be screwed down with thumb screws. The Servante has a lid. This makes it useful for rabbit productions for rabbit bag may be done away with. Rabbit is put into Servante and lid dropped down. When rabbit is needed, merely lift him out of Servante. It also has a clip to hold





a deck of cards. Altogether, it is the handiest all-around Chair Servante we have seen. It is made of metal and is covered with black cloth. See Price List.

Figure 18.

SECRET AND PATTERN:

To Prepare:

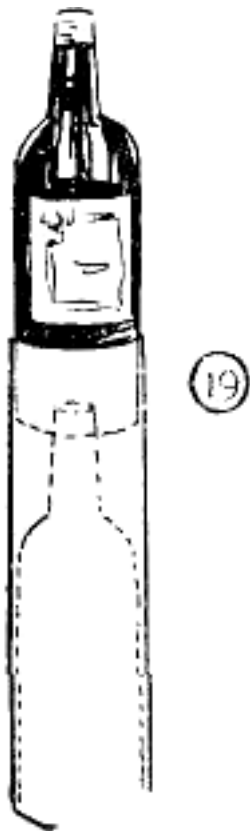
Prepare as for above experiment, but place extra shell over bottle and shell.

Attach Servante to rear of chair and throw cover over back of chair to screen it. Place chair on right side of stage. (All stage directions are given from performer's position facing audience.)

To Perform:

Assistant brings in tray with bottle and two shells over it, the two covers, and the glass. He sets this down on table, then steps back so that he is out of your way and yet can look on.

You perform the experiment as described except that you leave one shell over the bottle and use the other one to work with under the cover. When you come to part of effect where you say, "Things would have been different," cover the bottle and glass again without exchanging tubes.



Assistant has, in the meantime, edged up closer and is looking into cover with bottle. You pretend not to see him because you are busily engaged in talking to audience. Assistant reaches into top of cover and removes shell from bottle, being careful not to expose bottom of it.

Figure 19.



Assistant puts bottle under left arm, holding it in right hand.

Figure 20.

"Naturally, an experiment of this kind has many uses for it enables one to transport bottles or glasses of wine invisibly from place to place. While it had its uses in the old monastery of France in enabling the old monk to sneak out a few bottles to his friends once in a while, yet in this day and age, you can readily see that it has an even greater value. And strange to say, I have never known it to fail. If I command a bottle to appear under a certain cover here, it must appear there, regardless of the consequences."



As you speak, assistant sits down in chair which has the open Servante on the back.

Figure 21.

As he does so, he drops the shell over top of chair into Servante at rear. He keeps his hands in same position, how-

(44-13)



ever, to lead audience to believe that he still holds bottle under his arm.

Figure 22.

"As we all know, the bottle is under the tube at my right."

Point to tube at right. Audience laughs as they have seen assistant remove bottle from under that cover.

"And the glass is under the cover at my left."

Lift this cover about three inches to expose bottom of glass.

"Naturally, it is very important that we know the exact location of the aforesaid articles."

Assistant rises from chair and moves away a little in secret delight, still pretending to hold bottle under his arm.

"So we have the glass here....."

Lift up cover and shell inside, revealing glass.

"And the bottle there."

Lift other cover and show bottle. Assistant stares at bottle in surprise. He quickly raises his left arm and brings his empty right hand out. He turns around mystified, showing audience that bottle has disappeared. The effect is that the bottle disappeared from under assistant's arm and appeared under cover again. Assistant can now go offstage.

Then proceed with experiment as taught you in preceding effect by EXCHANGING COVERS and finishing effect.

Note - Another method of disposing of bottle under assistant's arm is to have him edge over to a wing on side of stage and have someone take it. He then advances forward again.

* * * * *

BOTTLE, BOTTLE, WHERE'S THE BOTTLE?

This is sort of a variation of Three Card Monte, in which the puzzle is to determine the exact location of the bottle. It is an interesting variation of the Passe-Passe Bottle and Glass.

EFFECT:

Performer places a bottle and two glasses at three different spots on the table. He covers bottle and each glass with a tube. Audience is asked to pick location of bottle and is unable to do so as bottle seems to jump about under the covers at performer's will. The bottle and glasses seem to change places under the covers at magician's command.

(44-14)

PARAPHERNALIA:

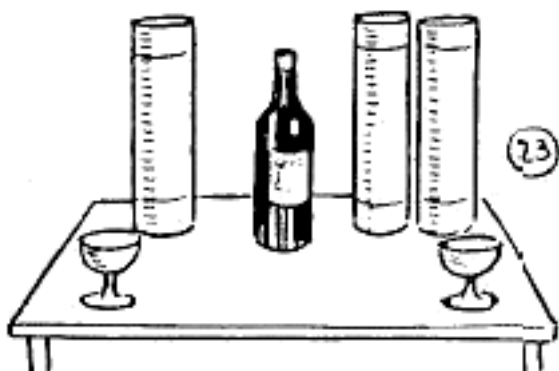
1 -- Comedy Passe-Passe Bottle and Glass Outfit, consisting of bottle, two shells, two glasses, and two covers.

2 -- An extra glass and a cover. We can supply you with these.

SECRET AND PATTERN:

To Prepare:

Place diluted grape juice or red-colored water into upper compartment of bottle. Have just enough to fill three glasses three-quarters full. Put the two shells over bottle with openings together at rear so that glass can be gripped through them.



You can have bottle, glasses, and covers on a tray and have them brought in and placed on table. Or you can have things arranged on table beforehand. If you have three stands, arrange them in a triangle with a glass on each of the front stands and bottle at rear point of triangle. Or you may use a card table for the experiment, placing bottle and glasses at points shown in Figure 23. Place the three covers at rear of table.

To Perform:

With table arranged as shown, start experiment with this pattern:

"A number of years ago a famous magician was spending Christmas at one of the fine chateaus in France. While he was entertaining with conjuring effects at a table, he noticed a bottle of rare wine, two glasses, and three cylindrical covers on a buffet nearby. An idea flashed through his head. He brought the bottle, the glasses, and the covers over to the table. From the bottle he poured wine into each of the two glasses."

Pick up bottle and pour wine into the two glasses, then replace bottle on table again.

"'This being Christmas,' he said, 'it is the ideal moment for a holiday game. The game is Bottle, Bottle, Who Has the Bottle?' He picked up the covers and, first of all, showed them to be empty, with a hole running all the way through each. We will play the game, providing the covers are large enough to fit comfortably over the bottle. He tried the first."

Place largest cover, A, over bottle and shells. Then remove cover, bringing outer shell away with it, and place on table.

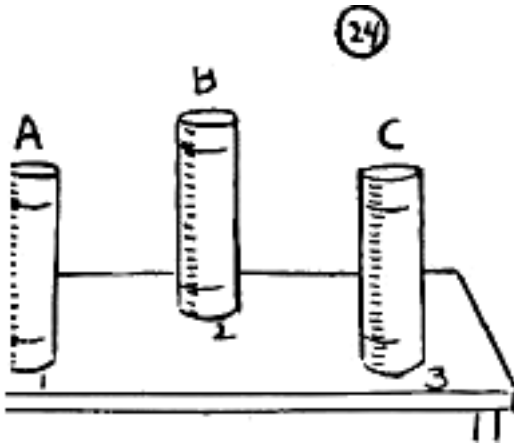
"It was an excellent fit. Then the second one."

Place another cover, C, over bottle, and lifting other shell up inside of it, place it down on table again too.

"It, too, fit well. And finally the third."

Place third cover, B, over bottle, then remove it and place on table.

"This also answered the purpose. Now, for the game. I shall try to play it for you in the same way the magician did that Christmas day in the French chateau. First, we cover each of the glasses."



Place cover A with large shell over glass at position 1. Place cover C with other shell over glass at position 3. Place cover B, empty, over bottle at position 2. You now have arrangement shown in Figure 24.

"The idea of this game is to keep your eye on the bottle of wine. It is very elusive, and if you look crooked, you may not be able to locate it. First of all, where is the bottle?"

Lift tube B and show bottle. Cover again. As you do this push plunger in bottle down so that glass under bottle is filled with wine.

"We are ready. Bottle, bottle, who has the bottle? Where is the bottle?"

Point to position 2 where bottle was shown.

"Here?"

Lift cover B with bottle inside and expose glass of wine under it. Place cover and bottle down on table.

"No. Here?"

Point to cover C. Lift cover and shell and place down on table. Another glass of wine is shown.

"No. It is here."

Lift cover A, leaving shell on table. It appears that bottle has jumped under cover A and glass has jumped under cover B.

"I am convinced that someone is not watching closely enough. Watch more closely and you will see less. Again let us play."

Cover each article with cover just removed from it, covering bottle last.

"You have seen the bottle. Can you find the bottle? Bottle, bottle, who has the bottle? Here?"

Point to cover A, where bottle was just seen. Lift cover and shell, showing glass.

"No. Over here?"

Lift cover C and show shell.

"On with the covers again."

Replace covers.

"Watch the bottle."

Raise cover C a few inches and drop again.

"Bottle, bottle, follow the bottle."

The moves from now on must be done snappily. Stand behind table. With left hand, lift cover C with shell, showing glass.

"Not there."

Place cover and shell on table as you lift cover A and shell with right hand and place them on table.

"Not here."

Lift cover B, showing bottle.

"Here. Right back to the old starting place. Once more, I shall give you a chance to locate the bottle."

Place proper covers over glasses and bottle again.

"Remember, the bottle is here in the middle."

Raise cover a little to show bottle, then drop it again.

"Are you ready? Bottle, bottle, where's the bottle? In the middle?"

Lift cover B with bottle, revealing the glass.

"No."

Cover glass again with bottle and tube B. Point to position 1.

"Here?"

Lift cover A and shell, showing glass.

"Not here."

Cover glass again.

"Then it must be here."

Lift cover C with shell, also showing a glass. Place cover and shell down on table to the left.

"Not here."

Lift cover A with shell and place them aside on table also.

"Not here."

Finally, lift center cover B, revealing the bottle.

"HERE."

Place cover down on table.

NOTE:

In stage presentation, it is not necessary to have covers examined by audience after effect has been performed. Merely handle the covers in such a free and easy manner as to convince spectators that tubes are empty.

In parlor work, you can get both shells back on the bottle again by exchanging the covers during the experiment. When you start on last part of routine, place cover C with smaller shell over bottle and place empty cover B over glass at position 3. At the end when the three tubes are off the bottle and glasses, pick up cover A with shell and drop it over bottle and smaller shell and remove cover quickly again. Say, "Yes, this is a funny bottle of wine. However, we still have the bottle, the two glasses, and the three empty covers."

If you are working close to audience, you can pick up all three covers together and let audience see through them. Ordinarily, this is not necessary. When you complete the experiment, you have reached a climax and can proceed with the next effect.

This experiment works out nicely with comedy version in which assistant steals bottle. Finally bottle appears under center cover.

* * * * *

A MAGICAL TRANSFORMATION

I give you here a modification of the famous old Bran Vase experiment. The familiar way of performing this effect is to pretend to fill the vase with bran, place a cover on it, then remove cover and bran has changed to candy, rice, lump sugar, or other small objects. The Vase is a pretty piece of apparatus and I shall teach you the manner in which I like to use it with a flashy ending to the effect.

EFFECT:

Performer shows a box of confetti and an empty vase. He dips vase into confetti and fills it to overflowing. He then covers vase, and in a moment uncovers it again. The confetti is found to have changed to candy, which may be passed around later to the children in the audience. Magician then turns vase over and yards and yards of paper ribbon stream down out of the vase to the floor. The effect is very pretty.

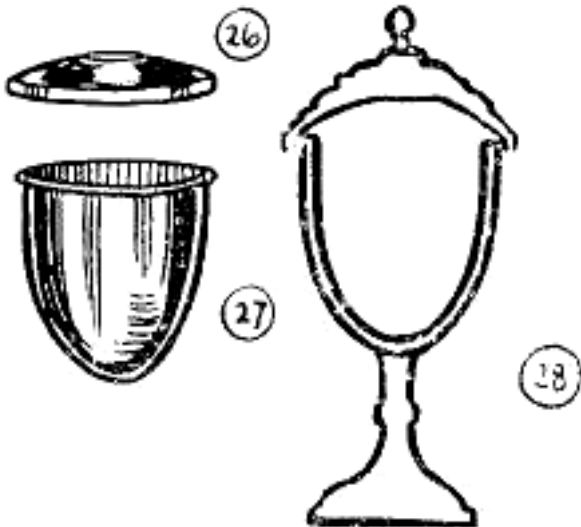
(44-18)

PARAPHERNALIA:

1 -- The Bran Vase.



Figure 25 shows how the vase looks when covered. It is just a beautiful nickeled vase with a cover to the audience. In reality, however, it is a clever mechanical contrivance for vanishes and productions.



Figures 26 and 27 show the extra lining and cover which fit snugly into the vase. This extra lining is easy to load into the vase and it holds the articles to be produced.

Figure 28 shows a cross-section diagram of the vase with the lining and covers on. The inner cover serves a double purpose. It keeps the load concealed in the lining and top of it is prepared to give appearance of filling vase with confetti, bran, or whatever is used.

2 -- A fair-sized box half filled with confetti or bran.

3 -- A five-inch coil of paper ribbon.

4 -- Candy, silks, a small animal, or some other load to be produced from vase.

5 -- A paper plate to put candy on, if you use candy.

SECRET AND PATTEN:

To Prepare:



Put a coating of glue over top of inner cover and spread confetti or bran all over it. In this effect we shall use confetti.

Figure 29.

When this prepared inner cover is placed in lining in vase, it gives appearance of vase full of confetti.

Take the coil of paper ribbon, and by pushing center of it down and spreading ribbon, form it into a cone shape to fit into bottom of lining.

Figure 30 shows coil of paper ribbon. Figure 31 shows the way it is spread to fit into lining of vase. Figure 32 shows inside of vase as it actually looks with paper ribbon in it.

Fill rest of lining with candy, silks, or load you decide on. Here we shall use candy kisses. Place inner cover on lining.

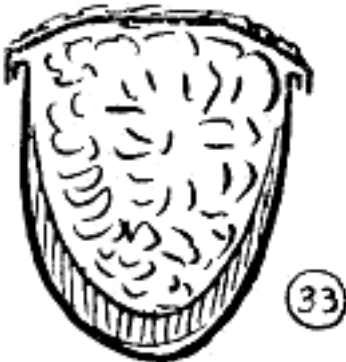
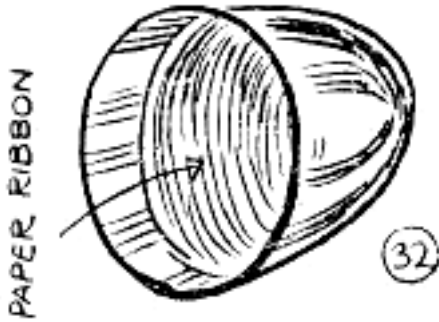
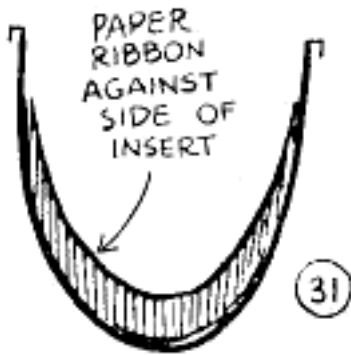
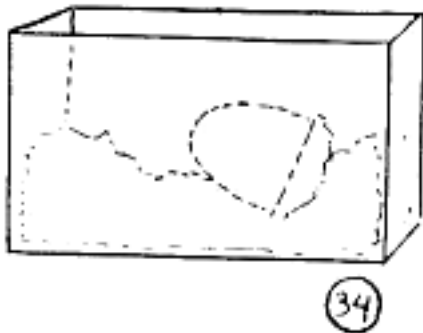


Figure 33 shows arrangement of insert or lining—with ribbon on bottom and candy filling it and confetti-covered top on it.

Place insert or lining in box of confetti in such position as to make it easy to scoop it up by vase secretly.



Figures 34 and 35.

To Perform:

Have a little girl come up from audience to help you. Assume that her name is Mary. Have her stand at your right. The vase and box of confetti are on the table, back a little.

(34)

Bring vase forward. Uncover it and give Mary and audience a view inside of it.

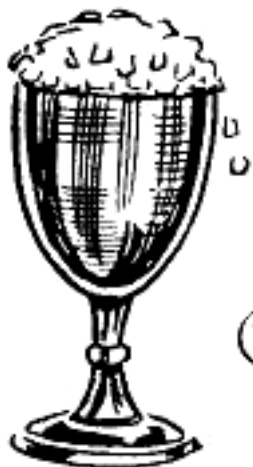
"I have never been able to determine, Mary, whether this is a vase, an urn, a flower pot, a drinking utensil, or a loving cup. It was presented to me by the governor of the Squeegie Islands."

Go to rear of table and place vase and cover down on table.

(35)

"I usually fill the vase with confetti and set it on the shelf. I have a box of confetti here for the purpose."

Tip box forward a little with left hand to show confetti but be careful not to expose insert in box. With right hand pick up some confetti and let it drop again. Pick up vase and pretend to fill it with confetti by scooping it down into the box. In reality, scoop up the metal insert inside of vase.



Put right fingers on faked top and bring vase upright above box. You can pick up quite a bit of extra confetti above faked top and then brush it off as if to even it. The confetti falling from the top gives impression that vase is full of confetti.

Figure 36.

(36)

Pick up cover from table and cover vase tight. Give vase to Mary to hold.

"There you are, Mary, a nice vase full of delicious confetti. Do you like confetti, Mary? It is quite evident that Mary is not overly enthusiastic about bits of paper. Well, Mary, if there is anything that you would rather have than confetti, just ask for it."

Whisper to her to ask for candy.

"What would you rather have. Candy? Then candy you shall have. Lift off the cover."

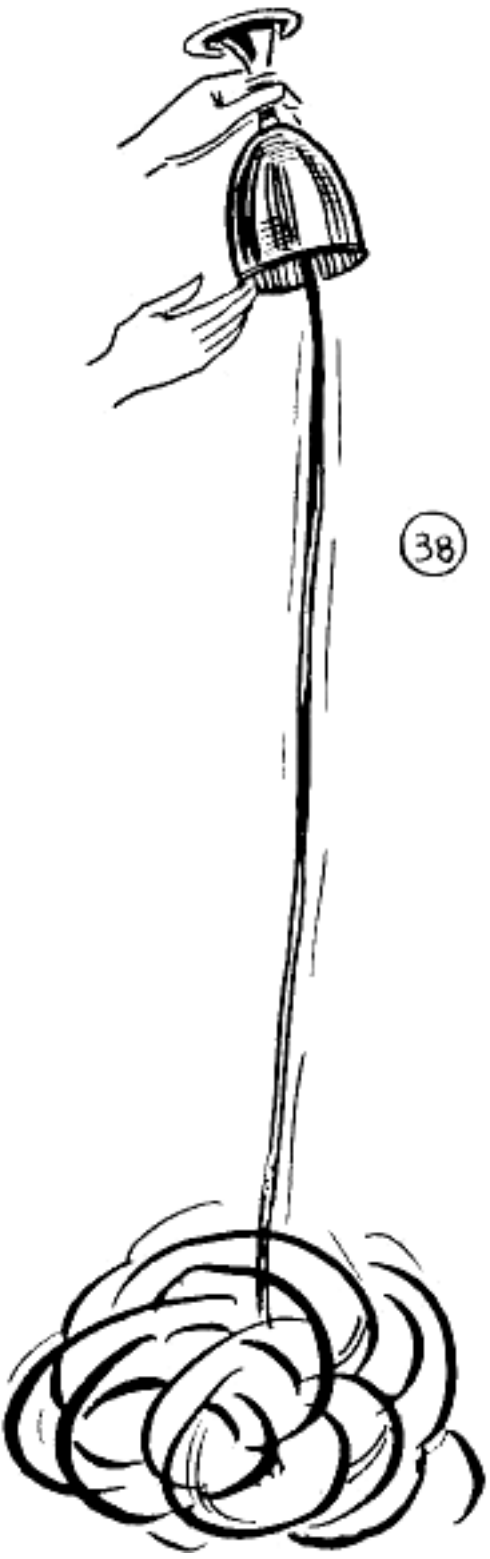


(37)

Mary lifts the cover, which carries with it the inner cover. Place double cover aside.

Figure 37.

Pick up paper plate and give it to Mary. Pour candy from the vase into plate. Be careful not to expose paper ribbon at bottom of insert.



"There, Mary, a whole plate of goodies. I suppose you wonder what became of all the confetti. Well, some changed into the candy and the rest was transformed into fairy ribbons."

Turn vase over. Start ribbon from center of roll and let it stream down to the floor. This effect of ribbon falling from the vase in a continuous stream is very pretty. Hold stem of vase in left hand and place right fingers just inside edge of vase to keep insert from falling out.

Figure 38.

38

When ribbon has fallen out entirely, show vase empty. Place vase and cover aside on table and dismiss Mary with her plate of candy.

* * * * *

A COOKING LESSON

This experiment introduces the Dove Pan, which has been a favorite piece of mechanical apparatus with magicians. It provides good comedy.

EFFECT:

Performer shows a pan somewhat like a chafing dish. Audience can readily see that it is empty. Magician says that he is going to give a lesson in cooking. He then proceeds to break an egg into the pan, putting shells and all in, then throws in torn up paper, seasoning and flavor. Finally, he lights a match and sets fire to the ingredients in the pan. He places a lid on the pan and then removes it again, and it is seen that the messy contents have disappeared and two doves fly out of the pan—or a baby chicken, a guinea pig, a small rabbit, or candy kisses have appeared in the pan.

PARAPHERNALIA:

39



1 -- A Dove Pan.

Figure 39 shows pan with cover as it appears to audience.

40



Figure 40 shows a cross section of pan and cover.

41

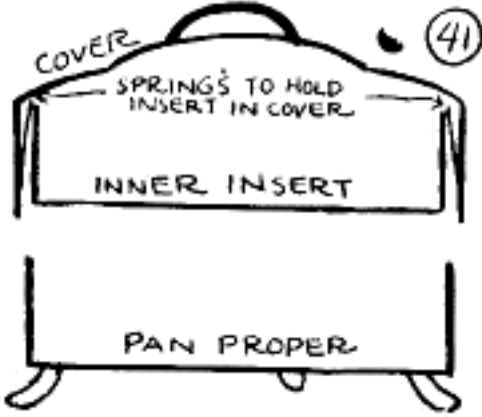
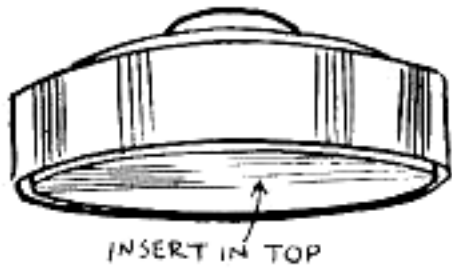


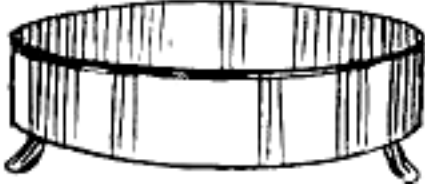
Figure 41 is a diagram showing construction of pan and cover. The pan has an inner insert or compartment. When this is placed in the cover, springs inside of cover hold it securely in place. Cover can be handled freely without danger of insert falling out. When insert and cover are placed down in pan, the insert fits into pan and is held there by friction so that cover can be lifted off without insert.



INSERT IN TOP

Figure 42 shows pan and cover with insert in it. The load is carried in this insert and is transferred to pan by placing cover on pan. There is enough space between bottom of pan and insert for eggs, paper, etc. We can supply you with good Dove Pan at reasonable figure.

(44-21)



SECRET AND PATTERN:

To Prepare:

Let us assume that you are going to produce two doves. Place them in insert of Dove Pan and adjust cover.

Have pan on table and loaded cover nearby to rear and side of pan. Have other cooking materials on a tray.

To Perform:

This effect may be performed quickly in pantomime or it may be pattered. When there are many children in audience, it is well to patter it.

"How would you like a lesson in cooking? Suppose I show you how to make a snoofle bird pie. First of all, we must have a pan."

Pick up pan and hit bottom to show it empty. Replace on table.

"We must start with an egg."

Break egg on side of pan and, holding egg above pan, let contents fall into pan so that audience can see it. Throw in the shells. This gives a comedy touch.

"Then a few yards of torn paper."

Pick up piece of paper about 12 inches square and tear it into small pieces, dropping them into pan.

"Some seasoning."

Season ingredients well with salt cellar.

"Some flavor."

Pour alcohol and a little ether into pan—just enough to give a good flame when lighted. You might put a little catsup in just before the alcohol if you desire.

"And a little fire."

Light match and touch it to the alcohol, putting match into pan. Allow flames to flash up for a few seconds, but be careful not to get pan too hot.

Figure 43.

Place loaded cover down on pan, being careful not to show bottom of it as you do so. Press cover down tightly to release insert into pan.

"And we have a snoofle bird pie."

Remove cover and doves fly out of pan.





Figure 44.

(44)



(45)

It is not always convenient to have doves, and for a children's performance, it is a good stunt to produce a pan full of candy kisses. You can then toss them, a handful at a time, to various parts of the audience.

Figure 45.

A comedy effect is to have the pan filled with a string of weiners. Baby chicks or ducks are interesting—or a guinea pig, small rabbit, or white mice.

* * * * *

THE WELSH RAREBIT

The amazing effect of building a fire in a hat borrowed from a spectator is made possible by the Welsh Rarebit Pan. It has found great popular favor.

EFFECT:

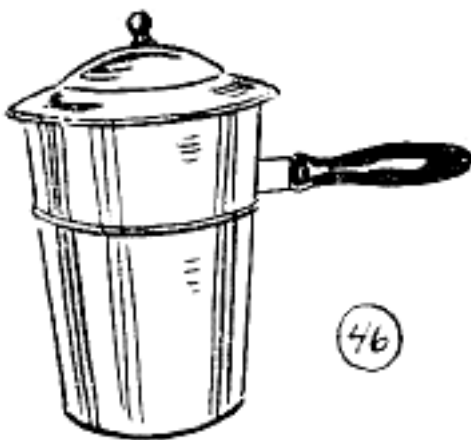
Performer borrows a gentleman's hat and a handkerchief. He places the handkerchief in the hat and places them on the table. Showing a pan to be empty, he breaks an egg into it, and places torn paper and other articles in pan. He then covers pan with lid. Now alcohol is poured over handkerchief in hat, fire is set to it, and flames are seen rising above hat. Magician waves pan above flames and then drops it into hat to extinguish flames. Cover is then removed from pan and out comes a guinea pig or other articles. The hat and handkerchief are returned unharmed.

PARAPHERNALIA:

1 -- The special Welsh Rarebit Pan.

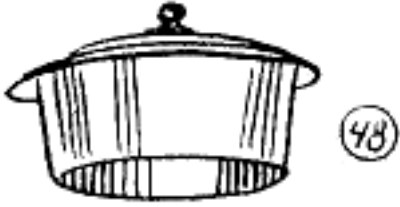
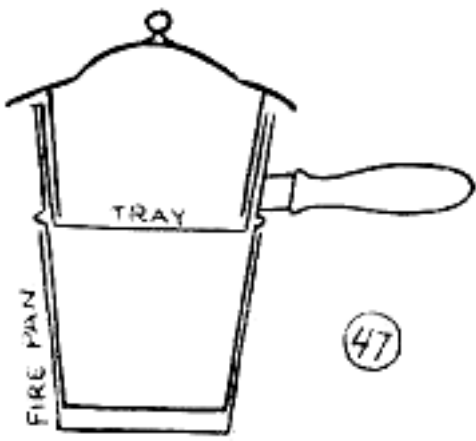
This is made of brass, highly nickeled, and is a beautiful piece of apparatus. It looks like a simple cooking pan with a cover, but it is also a clever piece of mechanical apparatus with extra parts.

Figure 46 shows pan as it looks to audience.



(46)

Figure 47 shows a cross section view of pan.



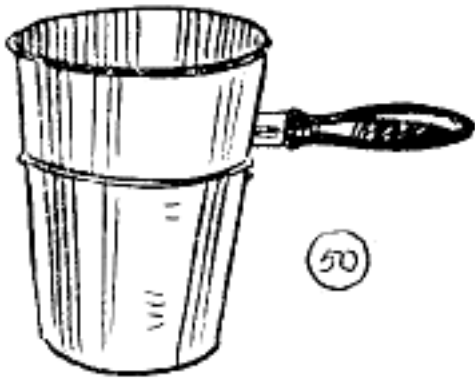
The pan consists of four parts. First there is the cover which has a piece attached to it, fitting into the upper compartment or tray of the pan.

Figures 48 and 49.



The third part is the largest compartment of pan to which handle is attached. And this, in turn, fits into the fourth or bottom part of pan.

(44-23)



(50)

Figures 50 and 51.

2 -- Small bottle of alcohol with bit of ether in it.

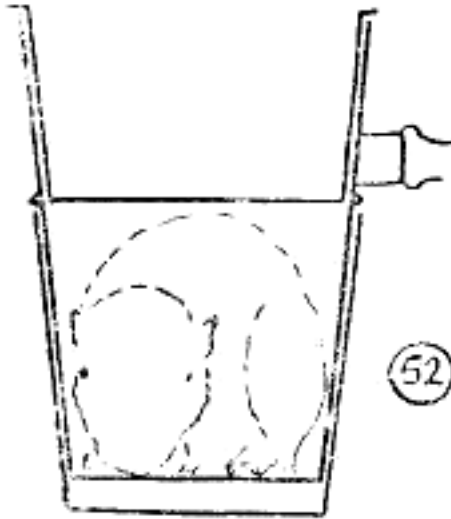
3 -- Matches, egg, piece of newspaper, salt cellar, and any other comedy articles to put into pan.

4 -- Guinea pig or small rabbit or some other load.

SECRET AND PATTERN:



(51)



(52)

To Prepare:

Suppose we use a guinea pig. Place him in third part of pan--the large section. On top of him place the second part or tray. Into fourth or bottom part of pan place a piece of white cloth to imitate a handkerchief. Place rest of pan into this bottom part.

Figure 52.

Have pan on table with cover nearby.

Do not leave animal in pan too long. Put him in just before you are ready for experiment. If he wiggles tray, place a cook book on top of pan. You can pretend to use book for reference during experiment.

Have alcohol, egg and other articles on a tray.

To Perform:

Borrow a hat and a handkerchief from gentleman in audience.

Come back to stage. Show hat empty and pull up the inner band. Place handkerchief in hat and put hat on table, opening upward.

"Have you ever eaten a magical Welsh Rarebit? It is a rare delicacy. Let me teach you how to make one. Take a kitchen utensil on this order."

Pick up pan by the handle but keep one finger under it to hold fire-pan in place. Then place fingers of other hand on top edge to keep tray from falling out. Turn pan upside down for a moment and then place it right side up again.

"And it will be necessary to have a stove. Perhaps the gentleman's hat is large enough for a stove."



(53)

Place pan down into hat for a moment, releasing the bottom fire-pan.

Figure 53.

Take pan out of hat, leaving fire-pan inside. Place pan aside on table. Inner band of hat turned up helps to screen pan inside of hat.

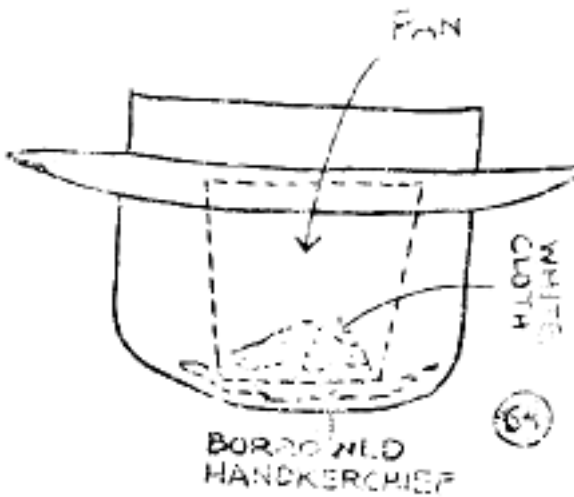


Figure 54.

"A good fit and just the right size for a stove. You do not mind my using your hat for a stove, do you, sir? Of course, not. We used to have stove pipe hats, but this can be a stove hat without the pipe. But now for the lesson in making a Welsh Rarebit. Gather together an egg."

Break egg on top of pan and let contents drop into upper tray. Throw shells in also. Tear up paper and place pieces in tray. Put in any other small articles you wish. Season with the salt shaker.

"Some paper, preferably a fresh newspaper, late edition, seasoning and such, and mix them well together. Cover well."

Place cover on pan. Press it down tight to grip tray.

Open bottle of alcohol, and pulling white cloth in firepan up a little, pour alcohol on it. Then allow cloth to fall back into pan. To the audience it appears that you poured alcohol on handkerchief and let it fall back into the hat.

"You do not mind if I put a bit of gasoline on your handkerchief."



Light match and drop it into fire-pan. Flames flare up out of pan and rise above hat.

Figure 55.

"And make a fire in the hat."

Pick up pan quickly and wave it over flames for a moment.

"I guess that is cooked enough."

Bring pan down into fire-pan in hat, apparently to extinguish flames, but in reality to secure fire-pan on bottom of rest of pan and bring it up out of hat.

"That is what is called dousing out the flames."

Place pan on table and remove cover with tray. Put cover and tray aside on table, being careful not to expose solid bottom of cover.

Reach into pan and take out guinea pig.

Figure 56.

"And behold a Welsh Rarebit, commonly known as pork pie."

Place guinea pig on table or give to assistant.

Pick up hat and remove handkerchief.



Note: If a small rabbit is used you can say, "and behold a Welsh Rabbit."

"Your handkerchief is, I believe, unharmed, and likewise the hat."

Show inside of hat, tucking down the band. Return handkerchief and hat.

A handwritten signature in cursive script that reads "Harlan Tarbell". The signature is fluid and elegant, with a large, sweeping initial 'H'.

TARBELL SYSTEM, INCORPORATED, Chicago.

* * * * *

LESSON 45

"Spiritualistic" Effects for the next lesson. These go over big with an audience and may be used individually or in a group to form part of a big evening's show. This is an excellent lesson and will give you interesting additions to your knowledge of Magic and your repertoire of effects.

(44-26)

SPIRITUALISTIC MAGIC

The subject of spiritualism or the communication of the dead with the living has been of interest to people in every age. The priests of ancient times made deception a science and an art so as to convince their followers that there was life after death. They preyed on the superstitious fears of the masses with cleverly concealed apparatus in their temples to make it seem that the spirits spoke to them. In Greece today one may see the speaking tubes, trap doors, secret passageways, syphons, trick altars, etc., by means of which they controlled the speaking idols, fire-spitting, water-projecting, and food-eating gods. These excite the admiration of the modern magician and almost cause him to turn green with envy, so clever and such good magic are these contraptions.

FAKE MEDIUMS PREY ON PUBLIC

From the time when the Fox sisters startled the world with their spirit rappings (1848), rogues posing as spirit mediums have mulcted millions of dollars annually from the simple minded and even from the intelligent but credulous, by using magic to prey on the most solemn and sacred emotion of the human heart, the longing to hear from a loved one beyond the grave.

Until about 1908, physical phenomena were the rage among spiritualists. In practically every large city there were hundreds of materializing, trumpet, slate writing, table tilting and rap producing mediums. Most of them prided themselves on working under "strict scientific test conditions," being tied with ropes, handcuffed, placed in sacks, etc.

PHYSICAL PHENOMENA EXPOSED

Due probably in a measure to the publications of David P. Abbott, Hereward Carrington, Henry Ridgeley Evans, Joseph F. Rinn, and others, about twenty years ago, exposing the methods of these fake mediums in various parts of America, investigators began to flash lights on trumpet mediums and to grab the "spirit" in a materializing seance, or in other ways to catch the medium cheating. A reaction set in and physical phenomena got a set back from which they have not yet recovered.

Today physical phenomena mediums are practically nonexistent except in the mid-western states. There are only a few slate writing mediums working today, while table tilting and rap producing mediums are little known among the present generation of spiritualists. Trumpet and materializing mediums are still found in the large cities of the middle west, but are few in number in other parts of the country.

Years ago most spiritualists believed in trumpet speaking, but today, even in Chicago, formerly the mecca of trumpet workers, probably only one in a hundred believes in that phase of mediumship. Trumpet and materializing seances today usually

have about one-fifth the number of people they had in the "good old days," and the earnings of mediums have decreased accordingly.

SERIOUS INVESTIGATION MADE

It should not be thought that all who attend trumpet and materializing seances believe in those phases of spiritualism, or that they have faith in the honesty of the medium. Many spiritualists attend for amusement or to investigate seriously in the hope that they will see genuine psychic phenomena or, at least, something interesting. There are those who claim that even when they know the mediums to be counterfeit, a certain percentage of the phenomena are genuine.

Millions of dollars have been spent by honest, sincere but mistaken seekers of truth in chasing that elusive will-o'-the-wisp, a genuine medium. In many cases, these people were spurred in their search by reading the publications made by analytical scientific investigators of the phenomena of spiritualism. I mean the writings of those highly intellectual, keenly intelligent men of science who have for years been patiently, laboriously, accumulating a vast mass of evidence dealing with spiritualistic and supernormal phenomena without the slightest thought to material reward -- Sir Oliver Lodge, Sir William Barrett, Dr. Walter Franklin Prince, Sir Conan Doyle, and others. Without due thought and preparation, these truth seekers I speak of rushed headlong into investigation of this abstruse and perplexing subject in the hope of experiencing the phenomena of which the scientists had written. In visiting public mediums, many were sadly disillusioned and others were convinced by the spurious phenomena they saw.

Counterfeit mediumship is built on newspaper and magazine stories of prophetic dreams and inexplicable ghostly happenings, on the love of the mysterious and supernatural inherent in all of us, and even more on the publications of scientific investigators of the phenomena of spiritualism.

Imagination runs riot in the religious atmosphere of the seance room. The prayers, singing of hymns, subtle suggestions of the medium or confederate, the will to believe, the darkness, the tenseness, all play on the emotions of the sitters and cause imaginary perception of things which do not occur. Mistaken observation, faulty reasoning, hallucination, and fraud account for most of the alleged phenomena.

Contrary to general belief, there is today very little information passed from one medium to another by mail or telephone, and the much discussed "Blue Book" is a myth. True, many counterfeit mediums have a "notebook" in which is recorded information that might later be used, but most fake mediums today do not use even a "notebook," and not once in a hundred times does a medium have advance information about a caller. If a medium cannot get what is wanted at one sitting, more sittings are arranged for.

It should be remembered that the spiritualistic phenomena reported by scientists are not the kind usually found in spiritualistic churches or seances or message meetings conducted by professional mediums.

Extensive literature on psychic science and numerous well-authenticated cases of spontaneous and induced supernormal phenomena of various kinds, such as telepathy, pre-vision, prophetic dreams, etc., reported by competent authorities, makes it seem that the subject has some merit. In my own personal experience, a friend of many years standing who is a non-professional automatic writing psychic conveyed to me information unknown to her or myself. It could not be accounted for on normal grounds, and I believe there is evidence of certain forms of supernormal phenomena which is well worthy of study by those who have the proper qualifications.

SPIRITUALISM AND MAGIC

It is a curious commentary on the public's love of the occult that people wish to believe that magicians are mediums. If a magician poses as a medium and presents his effects as spiritualistic phenomena, his earnings are greatly enhanced. Even if later (as has been done by the Davenport Brothers, J. S. Davies, George Leo Wilkins, and others), he exposes his methods and explains in detail how he fooled his audiences, many spiritualists will continue to believe him to be a genuine medium.

In spite of the campaign of the late Houdini against fraudulent mediums in Chicago and his exposes from the stage of the Princess Theater, many people were convinced that Houdini was a true medium and was only using exposures as a means of throwing people off the track from the real methods of accomplishing his other effects. Many people today still think that Houdini was a medium and that he escaped from his many manacles by dematerializing himself into spirit form and then materializing again.

Ernest F. Mansfield, of Chicago, a well-informed magician and inventor of magical effects, has had numerous apparently supernormal experiences and has made a deep study of spiritualism. Since 1905 he has been close in touch with the movement and is well known to mediums and lay spiritualists and scientific psychic investigators as a lecturer and investigator. For investigating purposes, he specialized in the methods of counterfeit mediums and is today probably the best informed man in America on that subject. His own original spiritualistic effects have mystified magicians as well as counterfeit mediums. Many of the latter sought to buy his secrets, but Mr. Mansfield refused to divulge them except to legitimate magicians. Because of that, many spiritualists believe his magic to be genuine psychic phenomena. In spite of his knowledge of magic and its divorce from spiritualism, however, Mr. Mansfield believes in the reality of certain phases of physical and mental spiritualistic phenomena, gained through some peculiar experiences.

Howard Thurston, as part of his show, presents "materialization" in a spirit cabinet in a manner that convinces many spiritualists that he is a real medium. Some honestly believe that they recognize in the "spirit" a dead relative and go to the stage door to so inform Thurston and seek his advice on spiritualistic matters. Needless to say, Thurston disclaims mediumship in his performance.

Harry Blackstone has a performing handkerchief that suddenly seems to become alive, apparently possessed of spirit power. In another effect - his shadow illusion - he walks away from his shadow and it seems that unnatural power of some sort is at work. Likewise, his famous rope tie, in which his wrists are securely bound together behind his back by a spectator and yet his hands are free in about two seconds and back again in the rope as quickly, suggests invisible aid. However, Blackstone is a magician and his spook effects are produced only by magical means.

Robert Gysel, of Toledo, Ohio, is another magician who has spent years in the study of spiritualistic magic. His performances are weird and uncanny and seem to include ghostly manifestations. Yet Gysel performs pure magic and is strongly opposed to the pretenses of the fraudulent mediums.

Joseffy, of Chicago, has a mysterious skull which he calls Balsamo. He places it on a piece of plate glass and suddenly the skull starts to look around and click its jaws. By clicking and opening its jaws, it answers questions. It performs as though endowed with life and operates under the most exacting conditions, even while resting on a spectator's lap. This would lead some people to believe that Joseffy is a medium, but he is only a magician.

A number of years ago, Ralph W. Read and Phillip H. Meyers, of Chicago, became interested in "spook" effects and brought out a telephone into which one could talk to and hold a conversation with a spirit, apparently. The instrument was without wire connections, and it produced a good effect. Then they built a tea kettle that would talk and answer questions. They presented this tea kettle to David P. Abbott, of Omaha, Nebraska, author of "Behind the Scenes with the Mediums." He modified it and gained a great reputation with his kettle presentation. The way Mr. Abbott presents it is uncanny. He also has another "spirit" effect. He takes pieces of canvas and produces spirit paintings on them, starting with a dim coloring and finally producing the finished picture.

Anna Eva Fay some years ago made a profitable tour of the country with "spirit" ties, cabinet manifestations, and mind reading.

In England, Maskelyne, Cook, and Devant produced mysterious "spirit" effects from time to time.

So you see, spiritualism and magic have had a close relationship for some time. The difference, however, between the fake medium and the magician is that the former deceives for fraudulent gain and the latter merely entertains and is paid for entertainment.

MODERN SPIRITUALISTIC MAGIC

Time goes by and conditions change even in spirit effects. Old time mediums were familiar with various restraints, such as handcuffs, rope and tape ties, etc., which the modern medium knows little or nothing about. The spirit medium working in a seance room does not need to be tied for her

following is so convinced of her power that they do not question her methods.

The magician, on the contrary, is placed in a different light. He has to convince his audience that he has no chance to do anything not legitimate. So he is often tied with tape or rope to a chair in such a manner as to make him apparently helpless.

You as a magician are out to entertain an audience, and so in presenting spiritualistic effects, you are entitled to use all the artifices of the stage and of magic necessary to create an effect. You do not claim to have supernatural power. You merely let the audience form their own opinions as to how you accomplish things.

I have simplified some excellent effects for you and have adapted the methods to make them suitable for your use as a magical entertainer. In this lesson I teach you how to perform seven interesting effects in spiritualistic magic:

- 1 - The Living and the Dead.
- 2 - Spirit Photography.
- 3 - The Psychic Paper.
- 4 - Double Slate Writing.
- 5 - Single Slate Writing.
- 6 - A Seance at the Table. Pencil Rapping.
- 7 - The Touch of the Mysterious Fingers.

* * * * *

THE LIVING AND THE DEAD

METHOD 1 -

EFFECT:

A number of people in audience are given slips of paper and are requested to write the names of living people and of dead people, one name to a slip. These slips are folded up by the spectators and dropped into a borrowed hat. Performer then reaches into the hat and one by one picks up folded slips. He holds them to his head and picks out the dead people from the living, reading the name aloud to verify it.

PARAPHERNALIA:

- 1 -- A sheet of writing paper.
- 2 -- A few pencils.
- 3 -- A borrowed hat.

SECRET AND PATTERN:

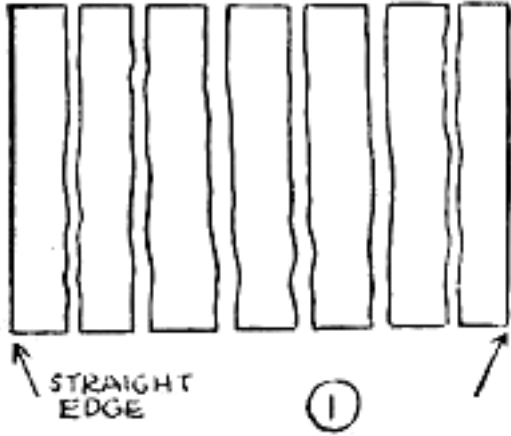
To Prepare:

This effect is entirely impromptu and requires no preparation.

To Perform:

Start with this patter:

"I need a few strips of paper. This sheet will do. I can tear it into a few strips."



Tear the sheet of paper into seven or eight strips. The first and last strip will have one straight edge while both edges of the other strips are uneven. Here lies the secret.

Figure 1.

Put the strips on top of each other, placing one with the straight edge third in the pile and the other one sixth. Or you may place both slips with straight edges on bottom of pile and pass them out at will.

"I am going to pass strips of paper among you for you to write upon."

Give upper slip to a spectator with a pencil. Say to him in a rather low voice:

"Just write the name of some living person on the slip."

Give next slip to another spectator.

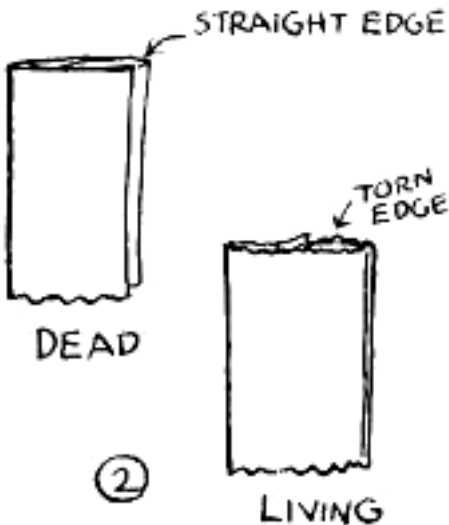
"And you Just write the name of some living person."

To a third spectator give the third slip with a straight edge.

"Write the name of a dead person."

Pass out the fourth and fifth slips with the request that these spectators write the name of a living person. The sixth slip has a straight edge and sixth spectator is requested to write the name of a dead person. The seventh person is asked to write the name of a living person.

"Do not let me see what you have written. When you have written a name, concentrate on it for a moment, then fold the papers up rather small and drop them into the hat."



Have slips folded as shown in Figure 2. Edges must show. If spectators fold edges in, you can easily straighten them out a little.

Pass the borrowed hat and let spectators drop folded papers into it. If desired, a member of audience may be allowed to collect slips.

"And I shall ask you, sir, to mix them up well."

Give hat to some spectator so that he may shuffle slips well by jiggling hat a little. Take hat again and place it on table, opening upward.

"On these papers have been written the names of living people and the names of departed ones who have passed into the great unknown. The names are well hidden and mixed up so that no one knows which is which. I want each of you who have written the name of a dead person to concentrate on that name. Strange as it may seem, the dead have a peculiar influence."

Pick up a slip from inside of hat. See whether it has a straight edge or not. If it has, you know the slip contains the name of a dead person. If not, you know it is a living person.



Let us suppose the first slip has the name of a living person. Place it against your forehead and close your eyes for a moment as though you are concentrating.

Figure 3.

"It is my intention to separate the dead from the living and to tell whether a name hidden inside the folded paper is that of a departed spirit or a living person. . . . This is the name of a LIVING person."

Open slip and read name. Toss slip aside in full view of audience. Then pick up another slip. Suppose this has a straight edge. Place it against your forehead as you did before.

"This bears the name of a departed spirit -- the name of a DEAD person."

Open slip and read name aloud.

"Is that correct? Who wrote the name of this dead person? You, madam? Thank you."

Continue this procedure, finally getting the second slip with the name of a dead person and reading it.

METHOD 2 -

EFFECT:

Similar to the effect of Method 1, except that performer actually calls out the names of the dead people before slips are unfolded.

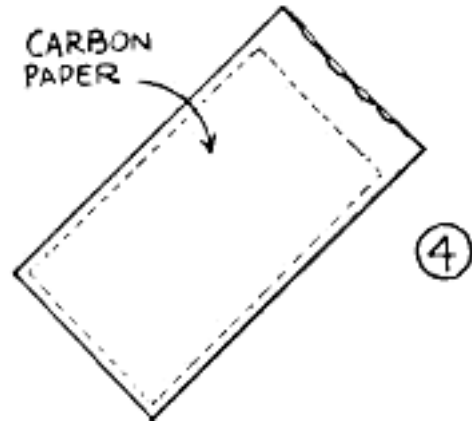
PARAPHERNALIA:

1 -- A sheet of commercial size writing paper.

2 -- A few used envelopes.

3 -- A sheet of carbon paper for use with a pencil.

To Prepare:



Inside of two of the used envelopes on the side of the address, paste a piece of carbon paper with the carbon side toward inside of envelope.

Figure 4.

④ Fold the piece of writing paper like a letter and place it inside of the envelope between the carbon and back of envelope. This paper may be a letter, blank on the back.

Now if someone places a piece of paper on the address side of the envelope and writes on it, a carbon impression will be made on the letter inside of the envelope. As the envelopes have been used and are taken from the inside coat pocket seemingly to fit the emergency and give spectators something to write on, they arouse no suspicion.

To Perform:

Tear sheet of paper into strips and pass them around with pencils as in Method 1. Give spectators envelopes to write on. Give the two people who write the names of dead persons each a prepared envelope to write on. After slips are ready, have them folded and dropped into borrowed hat. Collect envelopes, getting the two prepared envelopes on top.

"Men folks are often joshed about carrying their wives' letters around in their pockets and forgetting to mail them. I have been carrying these around with the intention of answering them some time. Here is one from an old college pal."

Pull out letter from prepared envelope with the carbon writing toward yourself. Pull it out just far enough to see name of dead person written on it and then push it back into envelope.

"He says, 'Am broke. Send me a hundred.' A hundred what? I haven't sent the hundred."

Place this envelope at bottom of others. Slip letter out of next prepared envelope a little to read name of other dead person written there.

"Oh, that's a letter from my tailor. I guess I had better put them away."

Thus in a joking manner, you have gained the information you need. Another way of getting these names is to turn your back for a moment on some pretense and then slip letters out of envelopes far enough to see names. Another method for getting the name of one dead person is to take letter from prepared envelope and on side opposite to that which has carbon writing scribble something with a pencil, while you tell audience to concentrate on names written. You pretend to show the manner in which the names were written and that gives you the excuse of taking letter from envelope and seeing name.

Sometimes by bulging open end of envelope, you can see inside and observe what was written.

Go through routine of taking folded papers from hat and placing them on your forehead to pick out the dead people. With showmanship tell the names of the dead persons. Assume that one is Napoleon Bonaparte.

"As I hold this paper on my forehead, I get an impression of an army, a French army -- an army of another period in history. Standing out is a small figure, his arms crossed. Has anyone here been thinking of Napoleon Bonaparte?"

Or suppose the name is a strange one, such as Mary Smith. Tell it in this manner:

"I get an impression of a woman. Her first name begins with an M. Just a moment -- I think I can catch it. Mary! That's right -- her first name is Mary. Mary Smith. Who was thinking of Mary Smith?"

You may open slips of paper and show spectators the names written on each.

METHOD 3 -

EFFECT:

Effect is similar to Method 1, except that names are written on cards and sealed in small manila envelopes. Performer is still able to pick out those envelopes which contain the names of dead people.

PARAPHERNALIA:

- 1 -- Any number you require of small manila envelopes.
- 2 -- Small cards to fit into the envelopes.
- 3 -- Pencils.

SECRET AND PATTERN:

To Prepare:

Make a small pencil mark or dot on those envelopes which are to contain the names of dead people. Have prepared envelopes on bottom of packet of envelopes and unprepared ones on top. Take them from top or bottom as required.

The pencil marks will not be observed by spectators. You can work this effect with a large group and quite a number of people writing. If you have a number of names of dead people, you can get your information by the "One Ahead" System, taught to you earlier in the course -- that is, getting the name of the first one, then opening an envelope which does not contain that name but is believed to by audience, and using this for the next name to call out, and so on.

Another method of marking "dead" envelopes at the moment is with thumb nail or finger nail on edge of envelope.

To Perform:

Have names written on cards and get cards of dead persons into envelopes marked by you. Collect envelopes and proceed to call out names. Hold one envelope to head.

"Here is the name of a dead person. Someone had the name, William Jennings Bryan, in mind. Correct?"

Look at audience, but at no one in particular. Audience believes that someone did write that name. This gives you an opportunity to tear open envelope and read what is actually written on card. Assume it is George Washington, but read aloud the name, William Jennings Bryan.

Proceed to go over envelopes calling out the "living" until you come to another one with a pencil mark.

"Here is the name of another dead person. Not LIVING, but dead. It begins with G. The initials are G. W. Who here wrote the name of a person with the initials. G. W.? Raise your hand. Ah, you wrote the name of a dead person, did you? You did. The initials are G. W. Was the first name George? It was. George Washington?"

Open envelope to see what is written on card and read the name, George Washington, aloud. Suppose card has the name, Ann Livingston, on it. Lay it face down on top of other card on table.

Proceed with this routine until you have picked out all the marked envelopes. As you still have one dead name to read, pick up an envelope containing the name of a living person and pretend it is the name of a dead one. After calling out name, you can open this envelope and take out card while you name the last dead person.

"There, I believe I have called out every name of a dead person. Did anyone write the name of a dead person which I did not call? . . . You see that I have been able to pick out the dead people each time without a mistake."

METHOD 4 -

Use slips of paper instead of the envelopes and proceed to read names of the dead as above, by the "One Ahead" System. At the finish you have opened the slip of a living person. Fold up this slip and pretend to place it on table. In reality, Thumb Palm it and slip it back into hat. Bring out this slip of paper last and give it to spectator. You can call the name out and have it verified by spectator as a finish to the effect.

(45-10)

METHOD 5 -

EFFECT:

Slips of paper are passed around as in other methods. When these are collected, they are burned. Yet performer is able to call out the names of the dead people.

PARAPHERNALIA:

1 -- Small pieces of paper about 2 1/4 x 2 3/4 inches.

A piece of commercial size writing paper will cut into 16 pieces of this size.

2 -- A large manila envelope.

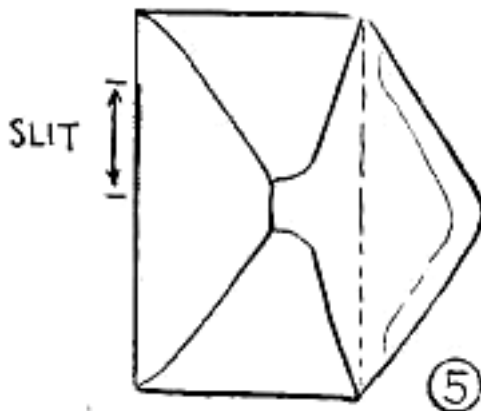
3 -- A candle in a candlestick.

Matches to light candle.

4 -- A plate or metal tray on which to place burning envelope.

5 -- Several half-size pencils.

SECRET AND PATTERN:

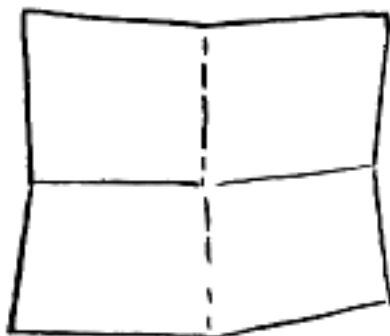


To Prepare:

Cut a two-inch slit in bottom of envelope.

Figure 5.

Have candle in candlestick on table at your left as you face audience.



Fold each slip of paper once across in each direction and open it out flat again.

Figure 6.

To Perform:

Light candle.

⑥ "I want to perform for you at this time an old spiritualistic rite as performed by Persian priests in days of old. It is still performed in some places on special occasions. First of all, I am going to pass some slips of paper among you that I want you to write on. Then when you have written, concentrate on what you have written, but do not let me know what it is."

Pass out pieces of paper and pencils to several spectators. Have some write the names of living persons and some the names of dead people. Remember those people who wrote the names of dead persons. Have slips folded. Your preliminary folding acts as a guide.

Remove prepared envelope from pocket and collect the slips. Place the slips containing names of living people at bottom of envelope and those containing names of the dead at top.

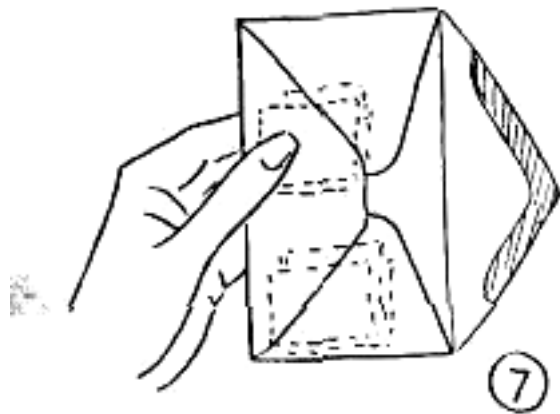


Figure 7.

Reach into envelope with right hand and push "dead" slips through slit a little so that they can be easily grasped by left hand. Back of left hand screens slips from view of audience and they are not aware of your movements here.

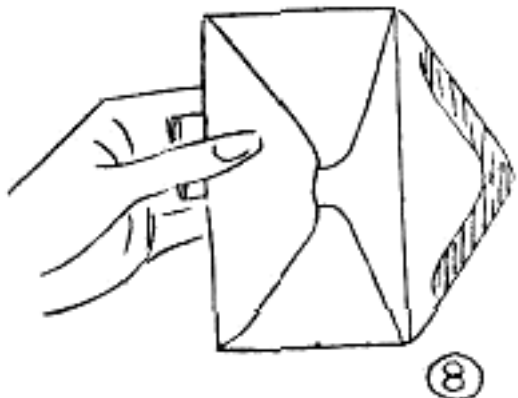
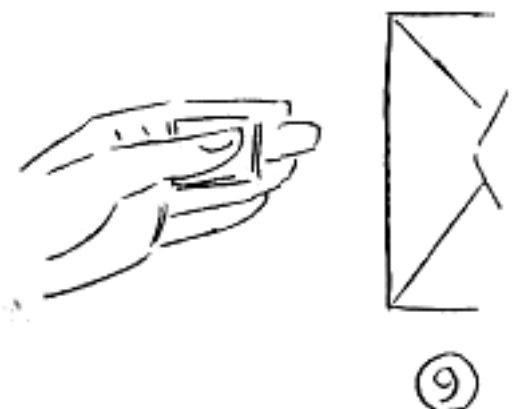


Figure 8.



Seal envelope and take it in right hand. As you do so, press left thumb down on "dead" slips and retain slips in left hand. Close fingers around slips to conceal them.

Figure 9.

"This rite was performed for certain reasons, but one of those reasons, no doubt, was to show the power of the priest. Members of the congregation would write the names of living people and dead people upon slips of paper which one of the ushers gathered and sealed in a large envelope. The priest took the envelope, faced the altar, and holding the envelope above his head, went through a number of incantations."

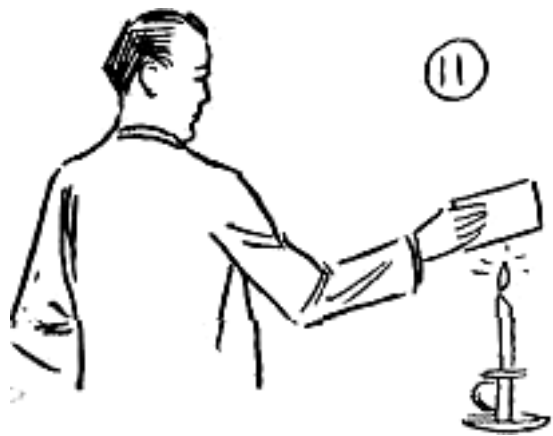


Turn your back to audience and hold envelope above your head in right hand. Hold fingers over slit to keep it closed.

Figure 10.

The moment your back is turned, put the "dead" slips from left hand in left lower vest pocket. Remove one slip, open it, and glance at what is written on it. Fold slip again and replace in vest pocket. You will have no difficulty in unfolding and folding slip with left hand if you hold it against you. Practice will enable you to do this very quickly.

"Then he would wave it above one of the candles nearby."



Place envelope a little above flame of candle, still keeping back to audience.

Figure 11.

While you are talking, get another slip out of vest pocket, open it, and read it. Then refold it and slip it into right lower vest pocket, out of the way.

"Then he would raise the envelope over his head again and finally place it in the mystic flame of the candle, setting it on fire."

Set fire to envelope and let it burn. Keep back to audience until you have finished your routine of taking out the two slips, reading them, and placing them back in their proper pockets.

Then turn to audience.

(45-12)

"Flames have played an important part in oriental ceremonies and are often associated with the psychic."

Drop remaining part of envelope on tray or plate. Face audience.

"An interesting part of the ceremony was the priest's power to separate the living from the dead. As you have noted, the names have been written of both living and dead people. You who have written the names of dead persons, will you please concentrate on those names?"

You know the names of two dead persons and can proceed to name them with proper showmanship.

"I get an impression of a departed spirit, of a woman. Barbara, I believe, is her name. Who is thinking of Barbara? Just a moment, I shall try to catch the last name. J -- J is the first letter, then I get an O. The name is Jones. Barbara Jones. Is that correct? It is. Thank you. A vision passes me of a man, a man of fair build. He is trying to say something. His name is Frank. Who is concentrating on the name of Frank? You, Madam? Thank you. Just keep your mind on that person for a moment longer. I do not seem to get the last name. I can only get a color -- it is a flash of red -- now it is darkening and has become brown. Perhaps it will turn to black. No, it is remaining that color. It is evidently a symbol. The color is opening and a face appears. Is the name Brown? Frank Brown. Right? Thank you."

This gives you an idea of the way in which the names are called and you can work up your own ideas around this as a nucleus. Various names may be expressed in symbolism to add mystery. Continue this until you have named all the dead people, turning your back and reading several slips at a time if you have more than two with names of dead people. Do not have too many of these. Finish effect by saying:

"In just such manner were the priests able to tell the dead from the living."



METHOD 6 -

This is similar to Method 5, except that instead of standing up with back to audience and reading slips under cover of body, you sit behind a table draped with a tablecloth and read slips under cover of table cloth. Unfold papers and read them in left hand while you burn envelope and talk to audience.

Figure 12.

METHOD 7 -

This is a good method to use if you have an assistant. Have small manila envelopes and cards passed out to spectators,

about two dozen of them. Ask about six spectators to write the names of dead people and the rest to write the names of living persons. Give marked envelopes to the former and plain ones to the latter. Have cards sealed in the envelopes and collected in a basket as described in Lesson 31, under A MODERN CRYSTAL GAZING ACT.

When basket reaches stage, raise handle and allow flaps to fall down and conceal collected envelopes, exposing the fakes which were in the sides. Empty duplicates into a glass bowl or on table and toss basket offstage. Assistant offstage picks out marked envelopes, opens them, and writes the names of the dead persons on a large card. He holds this up in the wings so that you can see it.

You pick up envelopes from glass bowl and hold them to forehead and pretend to pick out the names of the dead and call them out.

Another stunt is to have a lighted candle and set fire to the envelopes, allowing each to burn a little and then dropping it on the tray. You apparently read the name in the envelope by the flame.

The Changing Bag described in an earlier lesson is also a good way of collecting envelopes and changing them for duplicates. Slips of paper without envelopes may be used also in this method.

* * * * *

SPIRIT PHOTOGRAPHY

EFFECT:

Performer shows a piece of blank photographic paper and places it in an empty envelope, sealing it in. Spectator selects a card from the deck by cutting deck anywhere he desires. Envelope is then placed against selected card between the two parts of the deck. In a moment, envelope is torn open and photographic paper removed. On it is found a photograph of the selected card.

PARAPHERNALIA:

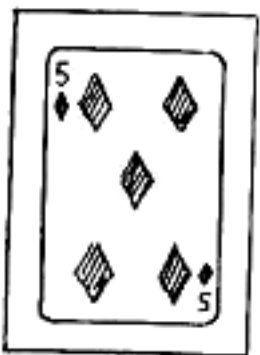
1 -- A double manila envelope, as described to you in Lesson 8.

2 -- A photograph of a playing card, say the Five of Diamonds. It should be of such size as to slip inside of envelope easily. If you have a camera, you can easily photograph a few cards for use on various occasions, so as not to use the same card too often.

Figure 13.

3 -- A blank piece of photographic paper to match that on which you have photograph of card.

4 -- A deck of playing cards.



(13)

To Prepare:

Place photograph of Five of Diamonds in rear compartment of double envelope. Seal the two flaps together.

Place blank photographic paper in envelope. Place the Five of Diamonds on "Top" of the deck.

To Perform:

Show envelope and remove photographic paper from it.

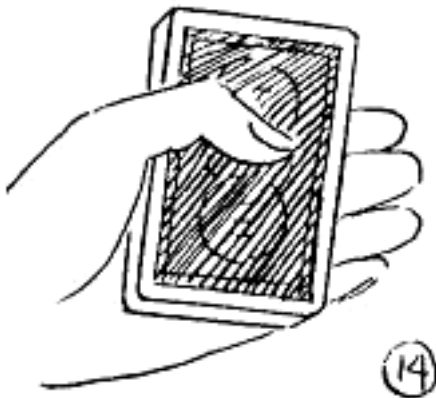
"For years the world has been more or less interested in spirit or psychic phenomena. Experiments with them have led to interesting results, many of which cannot be explained. For instance, there is one experiment which is very puzzling and I shall perform it for you. A piece of blank sensitized photographic paper is used."

Show blank photo paper freely and give to spectator.

"And an envelope."

Open envelope and show it empty.

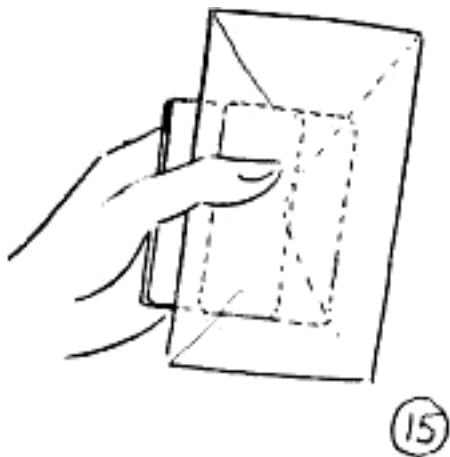
"Will you please place the paper in this envelope and seal it?"



Spectator places paper in envelope and seals it in. Hold envelope in right hand and pick up deck of cards in left hand with thumb on "Top" of deck.

Figure 14.

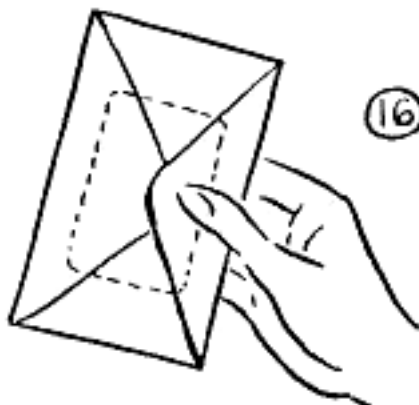
"I will initial the envelope for future reference. Give me your initials, sir. F. E. H. Thank you."



Place envelope in left hand on top of deck. The moment envelope screens deck, push top card to right about an inch and grip it by right fingers. Now place second and third finger-tips against card and release right hand. Bring thumb of left hand out on top of envelope.

Figure 15.

Remove pencil from pocket and write initials, F. E. H., on envelope so that they can be read from a distance.



Take envelope with right hand, concealing the Five of Diamonds behind it.

Figure 16.

"And if you will please shuffle this deck of cards well."

Spectator shuffles deck. Then ask him to place deck on your left hand. Have backs of cards up.

"Next, I want you to lift up any number of cards you desire -- in other words, cut the deck any place you choose. Then hold the cards a moment while I place the envelope on the lower part of the deck."

Have spectator lift up a section of the deck. Place envelope on top of lower section on your left hand with Five of Diamonds under it. Lift envelope again, leaving the Five-spot square on the deck.

"Before we do this, however, please remove the top card of those I hold in my hand. Look at it. and if you care to, show it to the others. Now replace the card on the deck. On this, I shall place the envelope and then have you, sir, place the cards you have on top of the envelope."



①7

Have spectator take Five of Diamonds, look at it, return it to packet in your left hand. Then place envelope on top of these cards and have spectator place his cards on top of envelope.

Figure 17.

"I want you to concentrate for a moment on the card you selected. One-two-three-four-five. Thank you, that is long enough."

Open cards and remove envelope.

"What was the card you selected, sir? The Five of Diamonds?"

Lift Five-spot from lower packet and show.

"The Five of Diamonds. That is correct, sir."

Replace card and place deck on table.

"I have tried to make everything fair for this experiment. First, I had you examine a piece of blank, sensitized photographic paper and place it in this envelope. Then you shuffled this deck of cards thoroughly, cut the deck any place you desired and noted the card at the cut. This card happened to be the Five of Diamonds. You concentrated on the card while I counted five. If the experiment has been performed correctly, I should be able to photograph by spirit means the card you selected and concentrated on."

Tear open the envelope, opening out the rear compartment. Show inside of envelope to audience and remove the photograph of card. Show envelope to be empty and toss it aside with open end to the rear. Show photograph of Five-spot.

"The Five of Diamonds. Even a better photograph than one might expect in an experiment of this kind, which goes to show that you have lent the best psychic atmosphere to the whole affair."

METHOD 2 -

In this case, you have a small piece of sensitized paper, such as Velox, which has been exposed to a film of the card and only requires developing to bring it out.

Place prepared paper in a regulation unprepared envelope and seal. At proper moment, open envelope, remove paper, and drop it into a small tray or saucer containing regular photographic developer. In a few moments, the photo appears on paper and it can be shown to audience. Be careful not to expose paper to much light before using. Carry it in a black envelope or inside of coat pocket until needed.

* * * * *

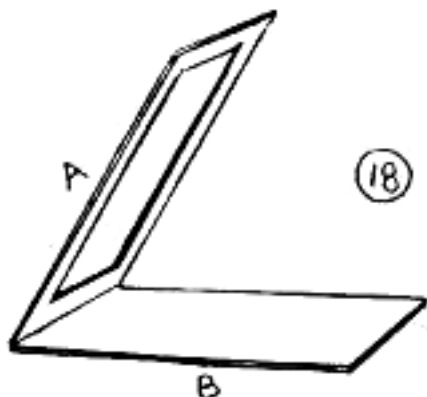
THE PSYCHIC PAPER

This is a good effect and very puzzling. It used to be a favorite dinner table effect with H. S. Paine.

EFFECT:

Performer places four different colors of tissue paper on the table, one red, one green, one blue, one black. A book of cigarette papers is picked up, out of which a sheet is removed and passed to a spectator for examination. Magician rolls this cigarette paper into a ball and places it on any color of tissue paper chosen by spectator. Another member of audience is then asked to select a number anywhere between one and one thousand and to name it. He is then told to pick up the ball and open it. There on the cigarette paper is the number which the spectator selected, written in the same color as that of the paper which the other spectator selected.

PARAPHERNALIA:



(18)

1 -- A cardboard apparatus which you can easily make. Take two pieces of cardboard, slightly larger than a sheet of cigarette paper. Cut a large rectangular opening in A. Then hinge the two pieces, A and B, together with gummed tape.

Figure 18.



(19)

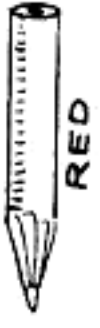
Place a sheet of cigarette paper on B, then fold A down over it. Place a rubber band around A and B to hold them together.

Figure 19.

2 -- Four two-inch squares of colored tissue paper -- red, green, blue, and black.

3 -- Four colored pencils, each about an inch and a quarter long -- red, green, blue, and black. In order to distinguish each pencil by touch, prepare them as shown in Figure 20. Leave the red one as it is. Make a small groove around the middle of the green one. Have a square pencil for the blue one. Make a large groove around the black one.

4 -- A book of cigarette papers.



RED



GREEN

20



BLUE



BLACK

To Prepare:

Place a blank cigarette paper in cardboard book and fasten with rubber band. Place in right trousers' pocket.

Also place the four prepared pencils in the same pocket.

Place the four pieces of tissue paper and book of cigarette papers in right vest pocket.

To Perform:

Remove tissues and cigarette papers and place on table. Arrange tissues in a row, a few inches apart, in this order -- red, green, blue, black.

Remove a cigarette paper from book and give it to spectator to examine. Place book aside.

"Just a cigarette paper."

Take cigarette paper from spectator and show it on both sides. Also show hands empty.

"Which I shall roll into a small ball and place on the table."

Roll cigarette paper into ball between the fingers and place on table in front of tissues. Show hands empty. Casually place right hand into right trousers' pocket.

"Now, select any one of the colored tissues on the table -- red, green, blue, or black. Choose any one freely."

Assume that spectator says red. Find the red pencil in your pocket with your finger-tips. Say to another spectator:

"You, please, think of any number -- say, between one and a thousand. Have you thought of the number? Name it aloud so all can hear and there will be no doubt about it later."

As you say this, get cardboard apparatus into position so that you can write on cigarette paper with red pencil. After a little practice you will have no difficulty in writing inside of your pocket without being detected. It is a natural attitude to stand with hand in pocket.

Assume that spectator calls out number 742. Write it as you repeat it after him.

"Seven - four - two. Remember the number 742. That was your own free choice, was it not?"

Slip rubber band from cardboard apparatus in pocket and take out cigarette paper. Roll it into small ball, similar to the one lying on table. Hold it concealed between first and second finger-tips and thumb of right hand and bring hand out of pocket.

Figure 21.

Say to spectator who selected color:

"I believe you selected the red paper, did you not? It would be better to place the ball of paper on the color you selected."

Pick up ball on table, grasping it between same fingers which hold numbered ball.

Figure 22.

Place finger-tips on red tissue and drop numbered ball on it, retaining blank ball in fingers. Bring right hand down to side. To audience it appears that you merely picked up ball from table and placed it on the red tissue. In reality, you made an exchange, placing the numbered ball on the tissue.

Figure 23.

"We'll place it right here in the center of the red tissue."

Adjust ball on tissue with left hand as you place right hand in right trousers' pocket and drop ball in it. Remove hand from pocket when it will seem most casual.

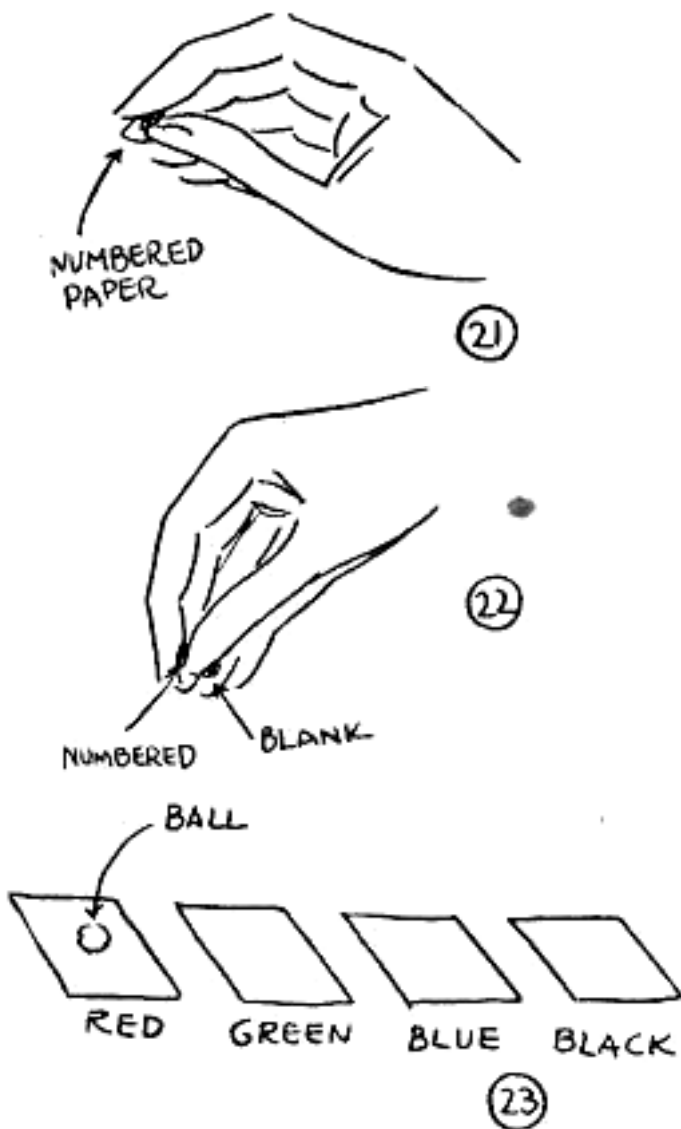
"Now, let us see how things stand. First of all, we rolled a piece of white cigarette paper into a ball, which we placed here on the red tissue selected by the gentleman."

Say to spectator who selected number:

"Your number, I believe, was seven . . ."

Hesitate as though you had forgotten number. Spectator names it.

"That's right. Seven - four - two. Concentrate a moment on it, while you, sir, concentrate on the red color. I do not know whether you believe in psychic phenomena or not or the power of mind over matter. You selected a number and you, a color I shall not touch the ball of paper myself. No one could possibly have known beforehand the number you selected, sir, or the color. However, to show you an interesting piece of phenomena, I want you, sir, to pick up the ball of paper and unfold it carefully."



742

24

Spectator picks up ball of paper and unfolds it. Take paper from him and show it freely, passing it out for examination.

Figure 24.

"And there you will find 7-4-2 written in red."

(45-19)

SPIRIT SLATE WRITING

Slate writing has been used in so-called spirit seances as well as by the magician for many years. It has resulted in a variety of methods. The conditions in the seance room are different from those of the magician's stage, and the methods which I explain are particularly adapted to the magician's use. They are easy to perform and very puzzling to the uninitiated.

The effect of slate writing is to show one or two slates, blank on both sides. Then in a mysterious manner writing appears on one side of the slate -- perhaps the answer to a question or some kind of message. Performer leads audience to believe that it was produced by an unknown force.

DOUBLE SLATE WRITING

METHOD 1 -

EFFECT:

Performer shows two blank slates and marks each side, 1-2-3-4, respectively. Slates are placed together, a tape is wrapped around them, and they are given to someone to hold or placed in full view on table. A spectator is asked to think of a question. Slates are then untied and a message has appeared on one of the slates.

PARAPHERNALIA:

1 -- Two school slates, the same size.

Figure 25.



25

2 -- A black flap for one slate.

Take a piece of cardboard painted dull black on one side and covered with a piece of newspaper on the other. Dust the black side with some chalk to match slate. Or flap may be painted dull, dark gray to match slate color. Japan paint or regular blackboard paint may be used. Some performers use a flap made of slate. This flap must fit into frame of slate and yet be loose enough to fall out if slate is turned over.



25A

Figure 25A.

3 -- A few pieces of newspaper on table, size of flap.

4 -- A piece of chalk.

SECRET AND PATTERN:

To Prepare:

In the middle of one side of one slate, write the figure 1 and an answer that will fit almost any question. If

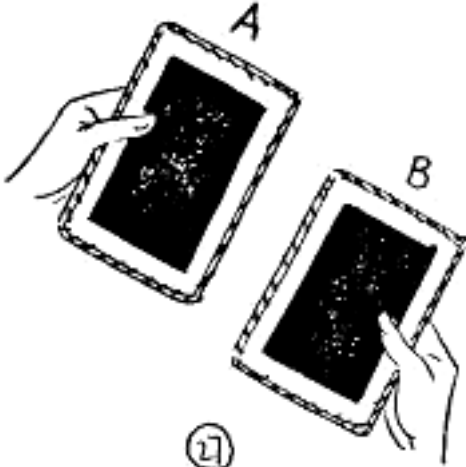


desired, the answer may be funny. Write, "Cannot Answer in Public," or "Time will tell," or make a row of question marks.

Figure 26.

26 Cover writing with flap, black side out. Place slate on table with flap up. On this place other slate. Have pieces of newspaper and chalk on table.

To Perform:



Pick up both slates. Remove the upper one with right hand and hold the other with left hand, keeping flap in place with left thumb.

Figure 27.

"For this experiment, I use two blank school slates. And I number each one of the sides."



Place unprepared slate in right hand down on table. Pick up chalk and draw figure 1 in center of flap of other slate as you did previously on the slate itself. Audience believes you are writing the figure 1 on slate.

Figure 28.

28 "One."

Turn slate over, holding flap in place, and make the figure 2 on other side.

"Two."

Place slate on table, flap side down and on the newspaper pieces, near edge of table. Pick up other slate and make a 3 on one side.

"Three."

Turn slate over and make a 4.

"And four."

Pick up first slate, leaving flap on table. As flap has newspaper backing, it is not noticed on other pieces of newspaper. Keep written side down and place this slate on other one. Figure 2 is on top and message is now between two of the slates.

"I shall ask you, sir, to tie these slates together with



Hand tape to spectator and have him tie slates together.

Figure 29.

29 "Now you may hold them for a while. Please hold them up so that everybody can see the slates all the time."

Say to another spectator:

"Have you ever been interested in spirit writing, sir? Have you ever communicated with the spirits -- the spirit of some departed friend? Perhaps there is some question that you would like to ask and have one of the departed answer for you. I want you to ask a question in your own mind. You need not say it aloud. Just think of it. Have you done so? Concentrate on it for a moment."

Say to spectator holding slates:

"Do you feel any peculiar sensation in the slates -- a sort of trembling? I believe you are a psychic yourself. Would you mind opening the slates now? Remove the tape and open them up."

Spectator does as requested. Pick up the slate with the message on it and show to audience.

"The spirits have written, 'Cannot answer in public.' Perhaps 'tis just as well for many things are better left unanswered."

NOTE:

If you have three or four question marks on slate, say, "I'm afraid you have even the dear departed brothers guessing."

SUGGESTIONS:

If you are working at a public performance with many strangers, you may pass out a few slips for spectators to write questions on. Gather slips in a Changing Bag or Spirit Basket, as described to you earlier in the course. On all the duplicate slips, have the same question written, perhaps something dealing with a local problem. Have a spectator reach into bag or basket and remove a question, reading it aloud. You then untie the slates and show the answer.



A simple method of forcing a slip of paper involves the use of a soft, felt hat. Push crown of hat up to form two compartments. Place duplicate slips, all containing the same questions, in A.

Figures 30 and 31.



Place right hand under compartment A, squeezing it tight from the outside to conceal duplicate slips.

Figure 32.

After spectators have written slips, have them dropped into hat and they will fall into compartment B. While talking, pass hat to left hand, squeezing compartment B closed with left hand and releasing compartment A. Shake hat up and down to mix duplicates and have spectator select one. He brings out a duplicate, of course, containing the question you had written. Slates are opened to show answer to question.

The slate writing method is good for the mathematical problem in Lesson 8, in which various spectators call numbers and the total mysteriously appears on a card – in this case, on the slate.

METHOD 2 -

This method is one of the best. The effect is similar to Method 1, except that no flap is required.

EFFECT:

Performer shows two blank slates and places a small piece of chalk between them. They are given to a spectator to hold, and when they are opened, it is found that a message has mysteriously appeared between them.

PARAPHERNALIA:

- 1 -- Two school slates the same size.
- 2 -- A very small piece of chalk that will fit between the slates.
- 3 -- If desired, a piece of tape to wrap around slates.

SECRET AND PATTEN:

To Prepare:

Write message on one side of one slate with piece of chalk. Until you learn effect, call this slate No. 1, the message side A and the other side B. The other slate is No. 2 with sides C and D. Just for practice purposes mark the slates.

Figure 33.

After you have routine mastered, omit letters as audience must see only blank slates.

Have small piece of chalk on table.

To Perform:

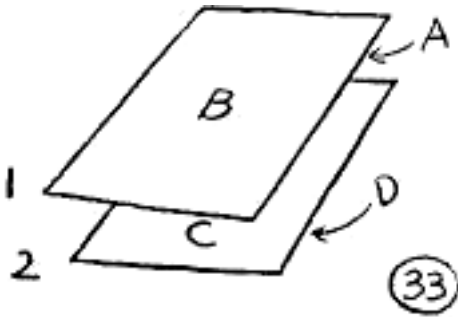
Pick up slates, holding them parallel to each other and close together. Have side B facing audience. Have both hands at about middle of edges of slates.

Figure 34.

Revolve slates downward to show side D.

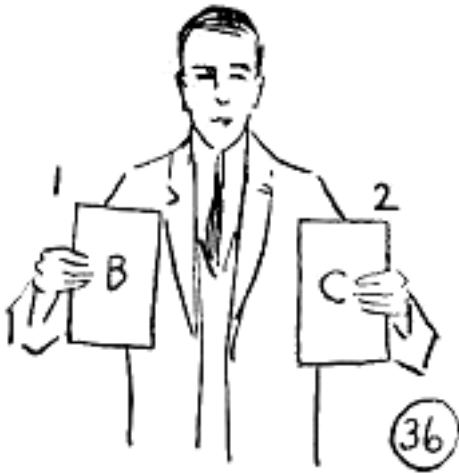
Figure 35.

Then bring slates back again to position shown in Figure 34.



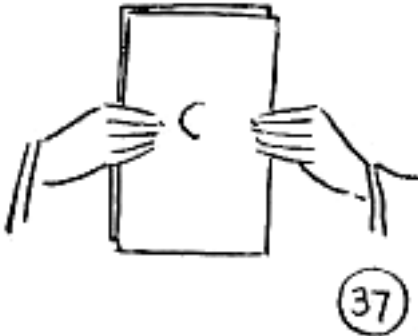
Separate slates, holding B in right hand and C in left.

Figure 36.



Bring slates together again, placing C on B. The message is now at the rear.

Figure 37.



Hold slates in left hand with C upward. Message is on the bottom.

Figure 38.



"Oh, I forgot to put a piece of chalk in between the slates. We must have a piece of chalk."

Lift upper slate and hold in right hand, showing C side to audience. Turn it over to show D, then C again. Place slate down on lower slate again to cover it only partially.

"Here is a piece of chalk."

Pick up the small piece of chalk and place it on C. Pick up lower slate with right hand and show side B to audience, concealing message at rear. Now place this slate on C and square up the two slates. B is uppermost and the message is now between the slates. Show sides D and B again by revolving slates as shown in Figures 34 and 35.

When you first place slates together, the skeptics in audience may feel that they would like to examine slates more closely. But when you open slates and show blank insides under pretense of placing chalk between them, audience is satisfied that slates are blank on all sides. Tapes may be tied around slates and spectator may be allowed to hold slates. Then slates are opened and message is found to have appeared between them.

* * * * *

SINGLE SLATE WRITING

METHOD 1 -

EFFECT:

Performer shows one slate, both sides blank. He places slate on table in full view of audience and mysteriously a message appears.

MODUS OPERANDI:

This is the same flap method as used in Method 1 of Double Slate Writing.

Write message on the slate and cover with flap. Have a few pieces of newspaper on table. In performing, show both sides of slate, then place slate flat down on table for a moment to drop flap on pieces of newspaper. Pick up slate again and stand it against something, message side away from audience. Or slate may be wrapped in newspaper and given to spectator to hold. At proper moment spectator removes newspaper and reveals message. Or with proper showmanship you turn slate around and show message.

Another way is to start to place slate in cloth bag, then suddenly decide to wrap in newspaper; you leave flap in bag.

METHOD 2 -

EFFECT:

Performer gives a slate to spectators for examination. He then washes both sides of it with a wet sponge. Slate is wrapped in a piece of newspaper and given to member of audience to hold. When paper is removed, a message is found on the slate.

MODUS OPERANDI:



The secret lies in writing the message backwards with soft white chalk in the middle of a sheet of newspaper.

Figure 39.

After slate has been examined, wash it with sponge. Then wrap it in prepared piece of newspaper so that chalked part of paper comes against one side of slate. Run hand over paper or rub it over knee as you wrap slate to get message on to slate. The wet slate causes chalk to stick to it. Be sure that slate is not too wet and will dry easily.

39

Give wrapped slate to a spectator to hold, then at proper moment, unwrap slate and crush newspaper into a ball and toss it aside. Show message on slate.

METHOD 3 -

EFFECT:

A slate is shown to be blank on both sides and is placed in full view on table or is wrapped up. Mysteriously a message appears on it.

MODUS OPERANDI:

Message is written on one side of the slate before performing. Secret lies in showing the same side of the slate twice in such manner as to lead audience to believe they have seen both sides. You were taught how to do this with a

card in Lesson 8. Go back and study these moves carefully so that you can perform them with the slate.

After apparently showing slate on both sides, place it against some object on table or wrap it up and finish by showing message.

* * * * *

A PARLOR SEANCE

This is a seance which can be performed impromptu in the parlor while a number of people are sitting around the table with you.

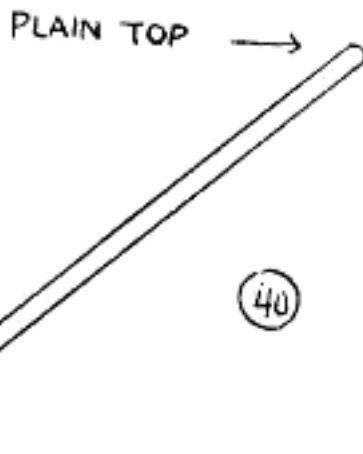
It is good as an after dinner experiment to be performed after the dishes have been cleared away. If you can secure a tambourine, a bell, a small musical instrument, a slate, a megaphone, etc., so much the better, but even with common articles, you can get a good effect.

PENCIL RAPPING

Spirit knocks are common in a seance. As spectators sit around a table, knocks are heard on the table. Finally, the knocks answer questions by knocking once for no, twice for yes, and three times for do not know. Here I give you an ingenious method of table rapping with a lead pencil. It may be done in full light or with only a candle burning on the table.

EFFECT:

Performer holds a lead pencil with the point on the table and fingers of right hand supporting it at the top in a vertical position. Suddenly knocks are heard and questions are answered with knocks which denote yes, no, or cannot answer.



PARAPHERNALIA:

1 -- A lead pencil with a plain top, no metal or eraser.

Figure 40.

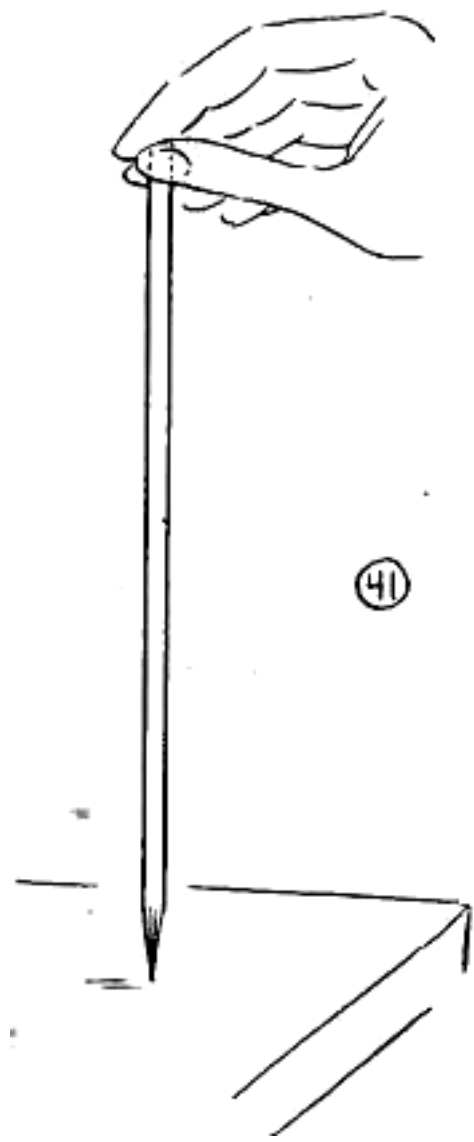
SECRET:

To Perform:

Show pencil to spectators seated around table. Place point of pencil on bare table not far from edge and hold top of pencil with right fingers. Have tip of first finger on top of pencil and thumb and second finger at each side, fingers and thumb touching. Third and fourth fingers are free.

Figure 41.

Press tightly down on pencil with thumb, first, and second fingers. Then move thumb slightly upward. A knock



will be heard on the table. It is just the sound of the thumb. The pencil does not move at all. If the table is entirely bare, the knock is quite strong. Try not to have anything on the table which will deaden the sound. Practice will soon enable you to perform this without being detected even though spectators watch closely.

A little rosin on the thumb helps you to grip pencil firmly and produce the raps. The plain thumb, however, held very tight against the pencil will produce a rap with only a little slip upward of the thumb.

By rapping twice for yes, once for no, and three times for "cannot answer," you can answer various questions asked by spectators. Four or five questions are enough.

* * * * *

THE TOUCH OF MYSTERIOUS FINGERS

This experiment may be performed while sitting at the table with only a candle or small electric light burning. It is very mysterious and ghostly.

EFFECT:

Performer asks spectators to hold hands to establish a contact. He places his hands on the table and has spectator to each side cover his hands with theirs. When all is arranged, suddenly a spectator feels a touch of mysterious fingers beneath the table. This is felt from time to time by various spectators. A tambourine placed on the floor under the table is jingled and perhaps thrown up into someone's lap. A bell is rung. All of this seems to be accomplished by some unseen force.

PARAPHERNALIA:

1 -- A pair of oxfords.

Have tongues of oxfords fastened on one side so that they cannot slip down. Place black elastic in oxfords instead of shoestrings. Or in emergency, do not lace oxfords up very high. It is necessary to be able to slip feet in and out of oxfords easily.



2 -- Right sock with toe cut off. This gives you free toe action.

Figure 42.

3 -- Tambourine, bell, etc.

4 -- A candle in candlestick.

SECRET AND PATTERN:

To Prepare:

Have specially prepared sock on right foot and have prepared oxfords on.

Have tambourine, bell, etc., handy.

To Perform:

Start with this patter:

"Phenomena are considered better when produced in the dark, as the forces seem to work better in darkness. However, I would like to see just what can be accomplished by dim light. It may be that nothing will happen and then again the forces may manifest themselves slightly or even with force. I will first place this tambourine under the table on the floor."

Place tambourine on floor under table, and near it, place the bell. They should be near the center of the table but near enough so that you can touch them with your feet.

"Now, each of you place your hands on the table and each one touch the other's hand so that a psychic connection will be established. Just touch the little finger of your neighbor's hand and keep the connection until the experiment is completed."

Have spectators place hands on table with little fingers touching, as directed. Place your hands together on the table and have spectator at each side of you touch his little finger to each of your hands.

"Now, the force that passes through one passes through all. Do not let go or the force is broken and there might be some danger of losing the phenomena. Sometimes, people are strong enough to carry force from one to the other without holding hands, but for safety, we shall touch hands. Remain as quiet as possible. Do not get excited and do not let go, no matter what happens. Also look at the person sitting opposite you and concentrate on that person."

This sounds good and accomplishes the purpose of keeping people from looking under the table. Impress the importance of touching hands on table and concentrating on person opposite them.

"Many times the first manifestations show themselves in the form of ghostly fingers. Sometimes the forces are so strong that you can feel these mysterious fingers grasping you. You can feel the movement of the fingers as they glide about through the ethereal substance."

It is customary in seances to sing some familiar hymn or song that lends good atmosphere. You can omit this.

As spectators sit quietly, slip your right foot out of the oxford. You can aid with heel of your left foot. With your toes touch someone lightly on the legs or knees and wiggle toes, then touch another, and perhaps a third. If all goes well, you can touch a number of spectators. When you touch someone, he or she may scream. Tell him quietly to remain still as nothing will harm anyone.

At any moment, you can slip your foot back into your oxford. You can at times operate with both feet to get even greater effect.

Pick up the tambourine with your toes over the edge. Shake it and move it around, finally throwing it on to someone's lap.

Place toes around top of bell and shake bell, then drop it on floor.

Slip foot back into oxford.

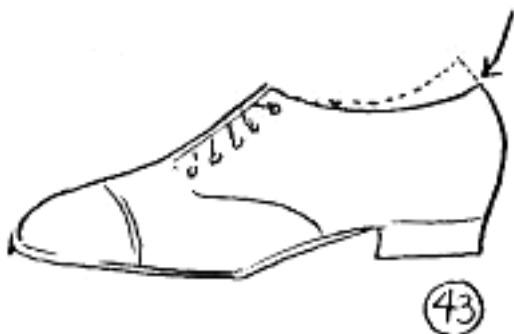
"The psychic influences seem to be at work tonight quite forcefully. Did anyone feel a ghostly touch of fingers? I felt them two or three times and even the tambourine and bell were influenced by the forces. We can now break the current. Just separate your hands and relax for a few moments."

Have spectator pick up bell and tambourine and place them on table.

NOTE:

I have performed this experiment while wearing just my regular oxfords. I would lace them low and use only my right foot. I would get this shoe on and off with the aid of the heel of my left foot. I do not hurry especially in performing as I depend on misdirection above the table.

Sometimes, a performer likes to work by having a spectator on each side place his foot on each toe of performer's shoes. If you perform in this manner, have a metal lining put in your shoes over the instep and toes so that when foot is removed, the shoe will not fall in.



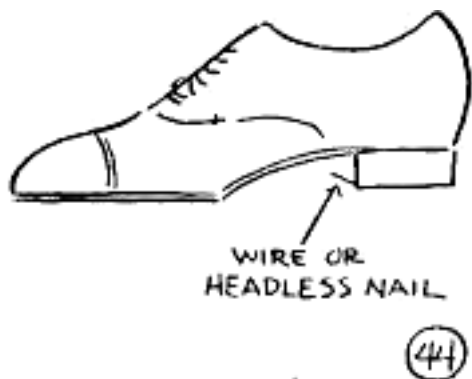
If you desire, you may have your shoes cut down to make it easier to slip foot in and out. If large size oxfords help, use them.

Figure 43.

* * * * *

GYSEL'S METHOD

Robert Gysel is exceedingly clever at foot manipulation and thus can produce some weird effects with bare toes as well as with his oxfords on. Here you learn his method of manipulating a bell or tambourine under the table without removing his shoe.

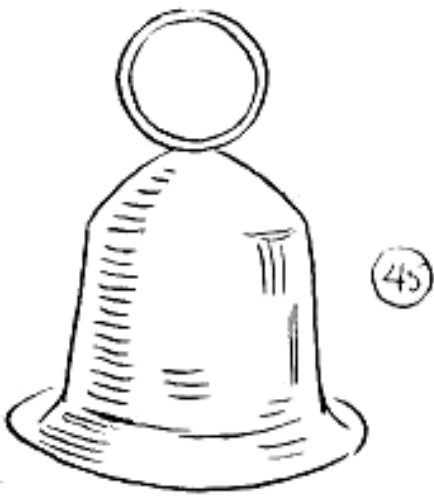


Gysel has a small headless nail driven into the inside inner edge of his heel. This is rather thin and painted black.

Figure 44.

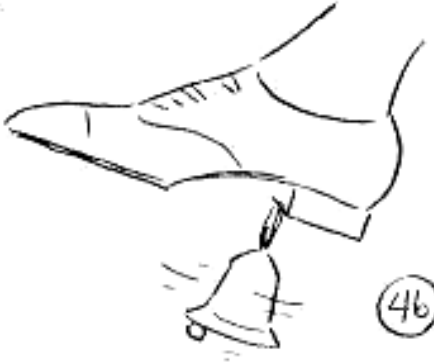
The bell used has a ring soldered to the top instead of a handle.

Figure 45.



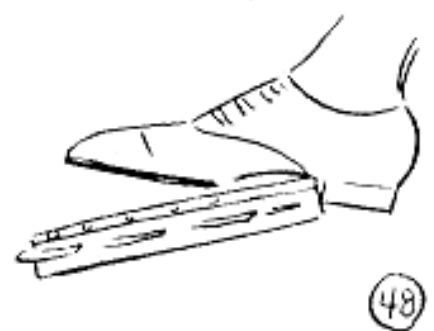
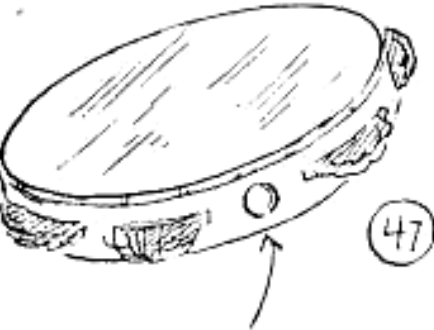
When bell is on the floor, he brings right foot over it, and getting nail through ring, picks bell off floor and rings it.

Figure 46.



He then sets bell down on floor again and releases foot. A tambourine may be manipulated in the same way through the hole in the side. If tambourine does not have opening, several round holes can be made in the edge.

Figures 47 and 48.



Harlan Tarbell

TARBELL SYSTEM, INCORPORATED, Chicago.

* * * * *

LESSON 46

In your next lesson you learn more good spiritualistic magic. We continue the study of the parlor seance and introduce dark seance work. We also discuss cabinet manifestations, in which mysterious things happen while performer is tied to a chair.

* * * * *

MORE SPIRITUALISTIC MAGIC

This lesson is a continuation of the work on Spiritualistic Magic, begun in your last lesson. It is designed for both parlor and stage presentation. To begin with, I want to give you the methods used in holding a magic "spirit" seance in a dark room. Then we shall go into "spirit" cabinet work.

It is well to train yourself in "spirit" magic as it permits of good advertising and publicity. Prominent in the advertising of Thurston and Houdini were the questions, "Do the Spirits Return?" and "Can the Dead Speak?" In this way you can present your work in the form of a question. You never claim to be a spiritualist or to use spirit power, but build atmosphere and let the audience think as they will. You perform merely as a magician and provide good entertainment.

* * * * *

THE DARK SEANCE AT THE TABLE

This act provides interesting entertainment at a party or at dinner when a few guests are assembled.

EFFECT:

Performer and spectators sit around a table. Each one places his hands at the edge of the table, touching the little finger of the person on each side of him. Spectators have their feet touching also. Performer's hands and feet are touched in the same way by the spectator on each side of him. A tambourine, a bell, a mandolin, and a trumpet are placed on the table. The lights are turned out and soon odd manifestations occur. The tambourine jingles and floats around in the air. The bell rings and floats around, too, while the mandolin gives forth sounds. Spectators feel ghostly touches and fingers run through their hair or down their backs. The light is then turned on and performer is seen sitting peacefully as in the beginning with his hands and feet held by spectators. Magician calls attention to a megaphone and places it on the floor at his side. Spectators again clasp each other's hands and touch feet and magician is again touched by spectators on each side of him. Light is turned out again, and suddenly the megaphone is thrown across the table. Mysteriously the table is tipped upward and falls back again, then all is quiet. Lights are turned on again and performer is still in same position, held by spectator on each side.

PARAPHERNALIA:

A tambourine; a bell; a musical instrument, such as a mandolin, ukelele, or guitar; a trumpet or some wind instrument (even a harmonica is good); and a megaphone or sheet of paper rolled into shape of one.

Various other articles may be used, as performer desires.

A slate can be used and placed on table with a piece of chalk. In the dark a message appears on it.

A glass of water may be placed on table and mysteriously emptied.

A piece of paper may be placed on table with a pair of scissors. The paper is cut in two in the dark.

A red silk handkerchief placed on table can change color.

A handkerchief placed on table can knot itself mysteriously, or a handkerchief full of knots can untie itself.

Dark seances offer many opportunities for puzzling effects even with common articles at hand. Thus they can be made entirely impromptu.

SECRET AND PATTERN:

To Prepare:

No preparation, unless you wish to supply special articles and have exchanges made.

To Perform:

Spectators are seated at the table. The effect may be produced with two others besides yourself at a small table or more people around a larger table. When there are just four people, you may each sit around a card table.

Place tambourine, bell, mandolin, etc. on the table, where you can reach them easily and yet far enough away so as not to excite suspicion.

"In dealing with the so-called spiritualistic or psychic or whatever the phenomena may be, it is customary to establish an harmonious circuit between those entering into the seance. This is best done by holding hands or merely touching one another's hands so that energy may flow from one to another around the circle. -Of course, even with the greatest of care, sometimes phenomena do not take place. Tonight, as an added measure of precaution, it might be well not only to touch hands to form a circle but to touch feet as well. thereby establishing a circuit on the floor. Now, first we shall place our hands flat on the table, palms down."

① Place your hands on the table to show spectators how to do it. Have about three inches between your thumbs.

Figure 1.

"It makes no difference how far apart your hands are, the idea being merely to establish physical contact with the one sitting on each side of you. I want you to touch your little fingers together."

Say to person at your left:

"Just place your little finger of your right hand on top of my left little finger."



To person at your right:

"And you place your little finger of your left hand on my right little finger."

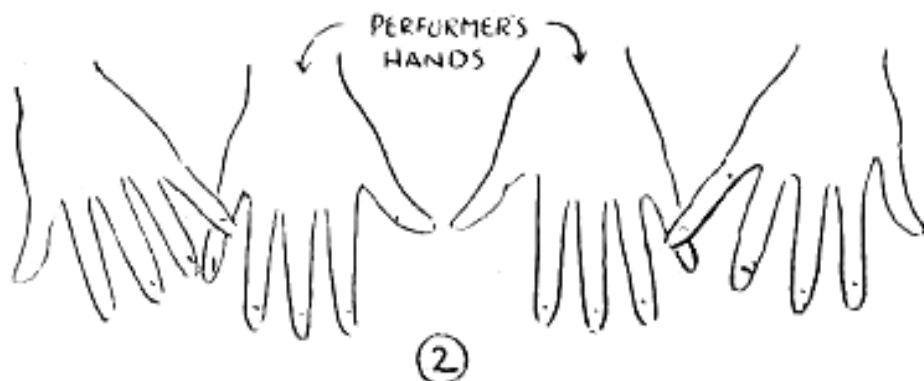


Figure 2 shows position of spectators' hands on yours.

"Now, everyone around the table hold your hands in a similar manner, just touching little fingers. That's fine. So as to establish further contact, will each of you sitting next to me place your foot on my foot? Now establish similar shoe connections all around the table. In the center of the table I have placed a few articles. Center manifestations may appear in any one or perhaps all of those articles, depending, of course, on the power we can generate from pur sitting. I shall have the light turned out. Under no circumstances turn it on again until I tell you to. Also dp not break the circle until I tell you. It is important that the circuit be established and continued until manifestations have ceased. There is nothing to be afraid of. At times, my hands move a bit to balance the current, but you who are sitting at my side must keep in contact with me all the time. Now I shall ask you who are sitting nearest the light to turn it out and then come right back to your place again, be seated, and establish the circuit again. You can find your way back to your position easily, I believe."

Spectator turns out light and all is dark. When he returns to position and touches hands of people to each side of him, continue your talk.

"The reason for sitting in the dark is that certain senses become more acute in darkness. In the light it is more difficult to concentrate -- too many things to distract our attention."



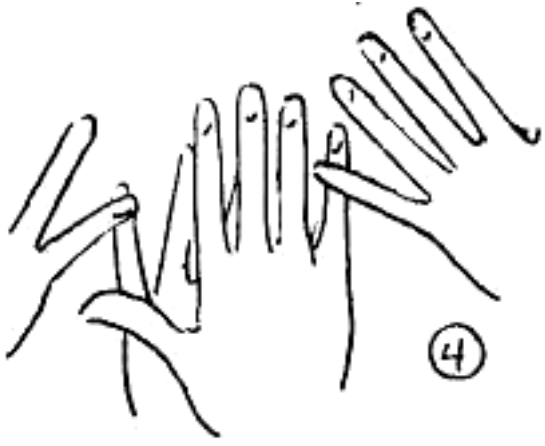
As you talk, bring your hands close together, then apart, and together again. Place right hand over left and move hands forward and back a few times. Be sure to keep contact of spectators' little fingers.

Figure 3.

You are preparing to work a ruse in which you can free your right hand unnoticed and in such a way as to lead spectator at your right to believe that he still holds your right little finger.

When right hand is over left, hold thumb and forefinger up high so that they do not touch little finger of spectator at your left. Your fingers are fairly wide apart. Slip right hand forward a little so that tip of left forefinger is under base of little finger of right hand.

Figure 4.



Move left hand forward, bringing forefinger directly under and parallel to right little finger. Be sure not to touch little finger of spectator on left during these moves.

Figure 5.



Now move both hands backward again. Suddenly draw away right hand, allowing spectator's little finger at the right to fall on the first finger of your left hand.

Figure 6.



When properly done, there is nothing suspicious about these movements. You are talking as this is going on. After you have made the change, say:

"Be sure not to break the connection. I distinctly feel the touch of those sitting next to me, as they, no doubt, feel my hands. Do not let go."

Move your left hand from side to side and backward and forward as you did before with both hands. You can let your hand rest and then move it wherever you think advisable.

"I already feel a slight sensation passing up my arms and over my shoulders."

YOUR RIGHT HAND IS FREE. IT IS DARK. PHYSICAL PHENOMENA ARE NOW EASY TO PRODUCE. In using right hand, be careful not to touch hands or arms of spectators sitting next to you. If you do accidentally, they may not think it is you.

"Sometimes, I feel a slight quiver going through my hair. a ghostly touch."

Suddenly move your flat right hand up the back and over the top of the head of the spectator at your right. This will be something of a thriller to that person.

"Sometimes, I feel taps on the shoulder."

Reach over in front of you and tap spectator at the left on the shoulder. Perhaps you can reach another spectator. Mysterious touches have a peculiar reaction on the person being touched.

Reach over and pick up mandolin. Wave it about, touching people with it and strumming the strings with your thumb as you wave it.

Pick up megaphone and talk through it in a disguised voice. Replace on table. If you have a tambourine, shake it and wave it about. Ring the bell and blow the trumpet if you have them. Make good use of whatever you have at hand.

This done, you must get hands back to position you held when lights were on. Move left hand back and forth a little, then slip right hand under left so that little finger is directly under left forefinger.

"Sometimes a current can be felt through the arms, though I will not say it can at this time. Move your hands back and forth a bit on the table, say about an inch or two."

Move hands back and forth a few times, and as you do so, quickly slip left forefinger away and let little finger of spectator at right fall on your right little finger again. This can be done with a peculiar jerky movement, if desired. Then continue moving hands back and forth.

"I felt a jerky movement then. Perhaps you felt it all the way around the table. I wish the forces would flow a bit more smoothly. Perhaps there was a slight break in the contact. Let your hands rest now. I feel the forces leaving mine. Please turn on the light until we rest up a bit. Everyone keep his hands in place except the one who breaks the circle to turn on the light."

Light is turned on and spectators see that your hands are still in the same position as at first.

"Now everyone let go of hands."

Hands are released. After a few moments you are ready to continue the seance.

"This time you just clasp hands. Before we begin again, I shall place this megaphone at my side on the floor."

Move your chair back a little to give you more freedom for manipulative work. Place megaphone on floor at your right side with small end up.

"Turn out the light again please."

The moment light is out, pick up megaphone with right hand and place it on your head.

Figure 7.

"Now we shall grasp hands so as to establish the circuit again. Also place your feet against each other, touching your toes."

Have spectator at left hold your left hand and spectator at right hold your right hand. Have them also place the toes of their shoes on yours.



"Clasp my hands fairly tight. Hold on. Do you think you can hold on all right? Fine. Sometimes there may be a slight swaying of any one of your arms or both. but do not let go. Keep the circle intact. I am going to try a form of levitation -- that is, the lifting of solid objects through magnetic forces. I have my feet and hands held for several reasons. One is to establish a more powerful circuit between you and myself. I feel a power entering me now. It is growing stronger and stronger. It is radiating outward. I shall direct it as you wish. The megaphone is on the floor at my right. Where would you like to have it directed to or hurled forcibly - straight ahead, backward, to the left or right?"

A direction is given by someone.

"Hold tight everyone. Sway a bit if you care to. The forces are getting stronger -- stronger - STRONGER."

Sway a bit with your hands raised from the table. Suddenly with a movement of your head, throw the megaphone in the desired direction. Be careful not to hurt anyone.

Now move back in your chair, raise your hands a little, and get your head down under the top of table. Raise table, tipping it up and down with your head. Finally let it fall back into place again. Sit upright and have light turned on again. Spectators see that your hands are still held by person to your right and to your left.

NOTE:

A table seance offers many opportunities for producing excellent effects. Study the conditions under which you work and make good use of the things you have at hand. You can inject good Showmanship into the work and make a fine impression.

* * * * *

THE DARK CIRCLE

This seance is performed with spectators seated away from a table in a circle around the room. In it, I teach you a hold that was popular with some of the old timers.

To Perform:

Have spectators clasp hands and place their feet against each other.

Place tambourine, bell, megaphone, musical instrument, etc., on a chair in front of you so that you can grasp them easily.

Sit down, placing a hand on each knee. Then reach over and clasp right hand of spectator at left with your left hand. Place his hand with yours on your left knee. Have spectator at right grasp your right arm above the wrist with his left hand.

Figure 8.

8

Have light turned out. Then say to spectator at your right:

"Pardon me just a moment until I get my handkerchief."



9

Have spectator release grip on your right wrist. Reach for your pocket handkerchief, blow your nose, and place handkerchief in pocket again. As you do this, bring your left leg up on your right, crossing your knees. Tell spectator at right to hold your wrist again. In the dark, he grasps your left wrist or forearm, thinking it is the right one. If he should feel your leg accidentally, he will think it is the right one as it is nearer to him.



Figure 9.

10

Your right hand is now free to carry on the seance. Produce the phenomena as you did in the table seance, jingling the tambourine, ringing the bell, picking up the megaphone and talking through it in "spirit voices." Finally place megaphone on head.



Figure 10.

Now you must get arms back into first position. Ask spectator at your right to hold you lightly. Suddenly jerk your left arm away from right spectator's hand and quickly slip right arm in its place. Uncross legs and replace right hand on right knee.

"Do not let loose. Hold on even though the forces tend to pull away."

Spectator at right grasps your right wrist again. To him it seems as though his hold on the arm was released by accident just for an instant. Your moves here must be done very quickly.

"I feel the spirit forces jerking forcibly at times, so hold tight now. I shall direct the forces on to some object. It is being lifted slowly off the chair, it is floating about the room, it is drawing back a bit again, now up and around high in the room. I shall direct more force into it, then suddenly withdraw it. Watch."

Suddenly throw your head forward or backward. The megaphone goes up into the air and then falls to the floor.

"The forces have left and it has been hurled downward to the floor. Hold tight until the lights are turned on."

Direct a spectator to break the circle and turn on the light, but be sure other spectators remain in place to see that your hands are securely held.

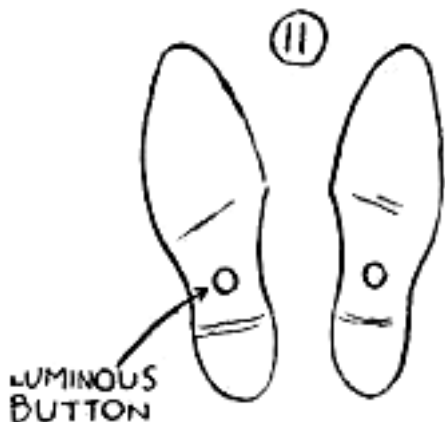
This is a simple mystery, but in the hands of Robert Gysel it is very spooky.

EFFECT:

Performer's hands are held by spectators or performer is tied to a chair. Room is darkened and in a few moments mysterious lights appear, floating around.

MODUS OPERANDI:

To Prepare:



Secure two luminous buttons, such as are sold in hardware or electrical stores. These are used for attaching to a wall near an electric button so that it can be found easily in the dark. Glue a button to the bottom of each shoe in the arch so that it will not interfere with walking.

Figure 11.

A bit of luminous paint on each shoe will also answer the purpose for this effect. Before the seance, expose the luminous surface to the light for a few moments.

Buttons can be arranged to be attached or detached easily. Magician's wax will hold them so that they can be placed on shoes and removed at will.

To Perform:

Have two spectators hold your hands, standing to each side of you. Or have them tie your hands behind your back and have

yourself tied to a chair.

Have spectators seated about the room. Lights are turned out.



After a few moments when spectators' eyes are accustomed to the dark, raise one foot and move leg around in the air so that light seems to float about.

Figure 12.

By lifting both feet and moving them about, you can get some odd floating light effects. To extinguish lights, merely bring feet down to floor again.

Have electric lights turned on again. Spectators see that you are still tied as in the beginning.

I wish you could see Gysel work a spirit seance and see the way in which he takes advantage of opportunities for Misdirection.

DR. BRIDGES' THOUGHT PROJECTION

This is an interesting effect by Dr. Milton A. Bridges.

EFFECT:

Performer shows a card, writes something on it, and places it in an envelope. He seals envelope and says that it is in his power to cause a person to think of what he wants them to think of. He says that he wrote a number on the card which he sealed into the envelope and he will cause a spectator to think of that number. When he counts three, spectator is to call out first number that comes into his head. When number is called, performer opens envelope, removes card, and shows number on it to be the same as number called by spectator.

PARAPHERNALIA:

- 1 -- An envelope.
- 2 -- A card -- a visiting or business card will do.
- 3 -- A pencil.

SECRET AND PATTERN:

To Prepare:

In center of one side of envelope cut a right-angle slit. This serves as a flap which can be lifted by the corner to expose card inside.

13

Figure 13.

Have envelope in pocket. Envelope may be regulation size or a pay envelope.

To Perform:

Bring out envelope and card. Show envelope, covering the slit carefully with thumb.

"Most everyone has heard of mental telepathy in which the performer picks up and expresses the thought of another person. In this experiment I am going to reverse matters and have you pick up the thought that I shall project. For instance. I shall just think of a number, say between one and one hundred. I shall write it down on this card."

Pretend to write a number on the card with the pencil. In reality, you write nothing, but keep this side of card from audience.

"Only I myself know the number which has been written. So that we can check up later, I shall place the card in the envelope and seal it in."

Place card in envelope so that center of it comes into

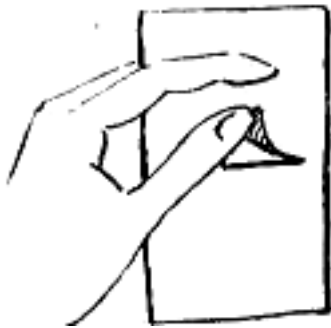


position under the cut flap of envelope. Seal envelope, concealing slit with thumb.

Pick out a spectator in the audience and ask him to stand up.

"You look like a good subject, sir. At this moment, you do not know what the number is which I have written, do you, sir? No. But when I count three, I want you to call out the first number between one and one hundred which enters your mind. Do not think of any number until then. When I say three, you mention the first number that comes into your mind. I shall think of the number, project my will, and I want you to pick it up in true radio style. Are you ready? One - two - three."

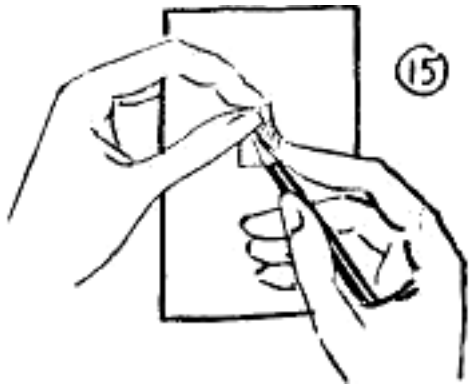
Hesitate a moment, looking straight at spectator. "Now name the number that came into your mind."



⑭ Spectator names number. Suppose it is 73. Hold envelope in left hand between first and second fingers with flap side away from audience. Raise flap with left thumb, exposing card inside.

Figure 14.

"Seventy-three. Did that number come naturally into your head? It did."



⑮ As you talk, write 73 quickly on card through opening in envelope. Let flap fall closed again. Do this in a nervous manner as if you were merely making motions with pencil. Look directly at spectator as you write.

Figure 15.

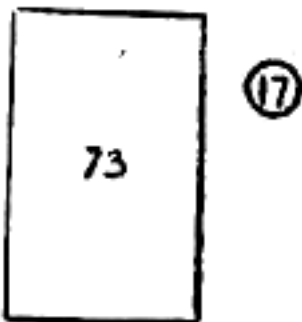
Now turn envelope so that flap side is toward audience, keeping flap concealed with thumb. Make a few seemingly unconscious movements with pencil on opposite side of envelope also.

"Naturally, you had no chance to see what has been written on the card, sir, nor did I tell you verbally what the number is that I was thinking of."



Tear envelope in two through the slit, thus destroying evidence. To do this, turn slit side toward you and allow card to fall down to bottom of envelope.

Figure 16.



⑰ Remove card and show number on it to be 73.

Figure 17.

"The number you thought of -- 73 -- is the number I projected into your mind and caused you to think of. It is the number I originally wrote on the card."

Show card freely and pass it to spectator.

* * * * *

THE SIBERIAN CHAIN ESCAPE

This is really an escape stunt but it is effective in seance work on a stage.

EFFECT:

Performer's wrists are bound securely together with a chain and chain is padlocked. A large handkerchief is thrown over performer's hands, and in a moment he is free. The chain and padlock are passed out for examination.

PARAPHERNALIA:

- 1 -- A Siberian Chain, which is a chain especially prepared with two rings.
- 2 -- A small padlock which will easily slip through links of chain.
- 3 -- A rather large handkerchief, preferably opaque.

SECRET AND PATTERN:

To Prepare:

The chain is 25 inches long and the links are one inch long and about 7/16 of an inch wide. You can get chain this size at a hardware store. Also get two nicked rings. Run one through link at one end of chain and the other through a link about 2 1/2 to 2 3/4 inches from end of chain.

The two diagrams in Figure 18 show arrangement of nicked rings on chain.

To Perform:

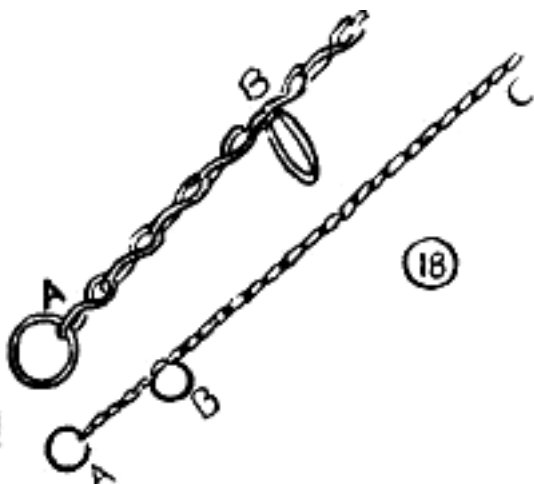
Start with this pattern:

"Siberia has been known for years for its harsh prison system. Men were put in chains there, especially during the reign of the czars. This chain is known as the Siberian Transport Chain. It was placed around a prisoner's wrist or wrists to render him helpless. I will place it on you, sir, to show you."

Put end C of chain through ring A and place spectator's right hand through loop in chain. Bring loop up to his wrist so that ring A is on top of wrist with thumb of hand held upward.

Figure 19.

(46-11)



"The rings are in the chain for a purpose. If there was an inclination on the part of the prisoner to pull away, the link of chain in the ring would cut into the flesh and cause great pain."

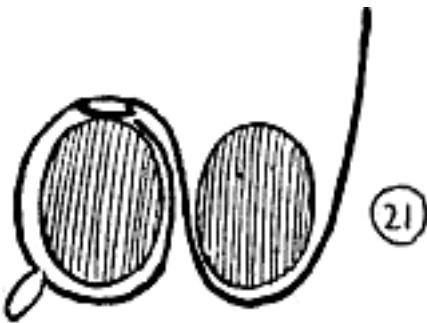
Pull down on chain a little to show how link digs into wrist. Spectator makes a wry face.

"I will not pull very hard, sir. I do this just to show how securely one can be held. I could pull you along with only one hand."



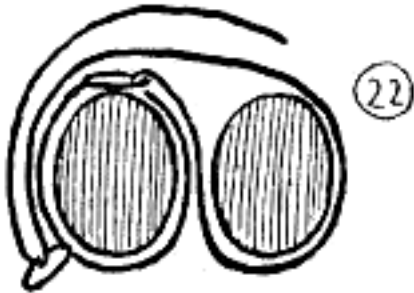
Remove chain from spectator's hand. Place it on your own right hand in same position, so that ring A is on top of wrist joint and ring B is outside of wrist to the right. End C of chain is toward left hand. Keep chain tight. Figure 20 is a diagram of arrangement of chain over right wrist in a view from audience.

"You will note how securely the chain binds the wrist. If the wrist were slipped back, the link in the ring would cause great pain. I shall ask you, sir, to tie the chain around my other wrist also."



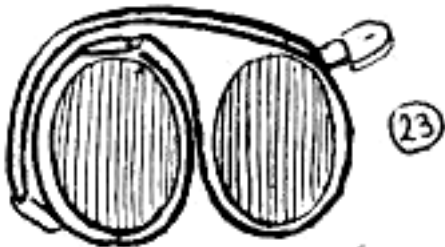
Have spectator bring end C of chain down under left wrist and upward again.

Figure 21.



Have him bring chain across top of both wrists to the right and put end C through ring B and bring it upward again.

Figure 22.



Chain is then pulled tight across top of wrists and padlock is put through last link of end C and around rest of chain on wrists. Position of padlock will vary with size of wrists.

Figure 23.

This tie looks very secure as links seem to cut into flesh they are so tight.

"This is one of the strongest chain ties known. Not only are the wrists bound securely together, but they are also bound separately beforehand to make them doubly secure. Were I to bind you in such a manner, you would remain this way until the lock were opened or the chain filed off. Will you, sir, please take the handkerchief from the table and throw it over my wrists and hands?"

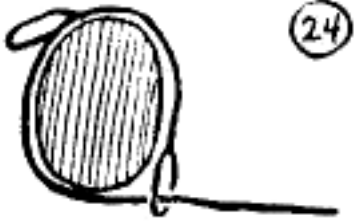
Handkerchief is thrown over wrists and hands to conceal method of release.

You may remain standing or sit down and pretend to go into a trance. Without much movement, raise left hand a little. This gives slack in the chain, enabling you to release first your left hand and then your right. Suddenly let chain fall to floor.

Remove handkerchief, show hands free, and give chain out for inspection.

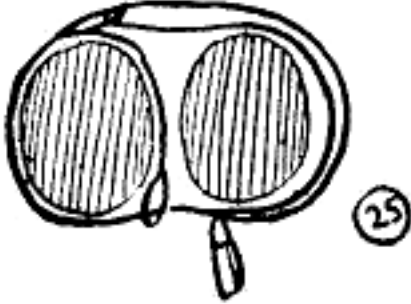
TO BIND A SPECTATOR:

Should it ever be advisable to place the chain on the wrists of a suspicious spectator, you can do so in a manner which will not permit him to escape.



Place chain on his right wrist. Be sure that ring A is at the bottom and inside of wrist instead of at the top. Bring end C of chain through ring A toward the left.

Figure 24.



Have him place left wrist on chain. Bring chain up around left wrist and across top of wrists to ring B. Put chain through this ring and bring it back as far as it will go and padlock.

Figure 25.

The placing of this chain is similar enough to the way in which you bound your wrists not to arouse suspicion, yet there is not enough slack in this method to allow escape.

We can supply you with Siberian Chains complete with rings, locks and keys.

* * * * *

THE CABINET SEANCE

This seance is especially good for the stage, although it may be done in the parlor. It enables the performer to carry on his work in full light without being detected.

EFFECT:

Performer is tied to a chair with tapes or soft clothesline and is placed inside a cabinet - or a curtain is drawn in front of him. A cane placed in his lap mysteriously appears over the front curtain. A tambourine and bell, placed in cabinet, jingle and ring in a baffling manner. A glass of water placed on performer's lap vanishes and glass is found in performer's mouth. A slate placed on his lap is found with a message written on it. At conclusion, performer is still seen to be tied securely.

PARAPHERNALIA:

1 -- Several yards of half-inch tape or soft white clothesline, cut into about three-foot lengths.

2 -- A chair.

3 -- Tambourine, bell, cane, glass of water, and slate with chalk.

4 -- A cabinet with metal or wooden frame and covered with cloth. A draw curtain should be in front of cabinet. Cabinet should be large enough to hold a chair with a person sitting in it.

5 -- If a cabinet cannot be used, arrange a small curtain suspended from a wire or rope behind which performer's movements can be concealed.

SECRET AND PATTERN:

To Prepare:

The seance itself is practically impromptu. However, if you desire to use a cabinet, you may have it built.

A good metal worker or carpenter can fix up a frame for you. This should be of metal pipe or of wood and so arranged that it can be easily taken apart and put together. It should be made to fold up so that it can be packed for carrying from place to place.



26

Figure 26 is a diagram, suggesting the frame which may be used for cabinet.



27

Cabinet should then be covered with cloth -- fitting it over the sides and back. It may also be stretched over the top. Cloth covering should be so arranged as to be easily put on frame and removed.

Figure 27.



28

About a foot from top of frame stretch a wire across front of cabinet. Make a curtain with curtain rings at top to be strung on this wire. Attach curtain to one side of cabinet to prevent exposure when curtain is drawn across front of cabinet.

Figure 28.



29

The cabinet is merely a means of covering your movements in the seance but it also adds good Showmanship. When you cannot use a cabinet, you can get a good effect by just stretching a wire across the room or stage with curtain suspended from it by curtain rings. Curtain need not extend all the way to the floor. Assistant can slide this curtain back and forth in front of you, as required.

Figure 29.

(46-14)

To Perform:

Let us say that you will use the cabinet. Have a chair nearby with tambourine, bell, etc., on it -- also the tapes or rope. Suppose we use soft white clothesline. Also have a chair for you to sit on. Your assistant should be at hand to help you.

"In presenting a seance of this kind, it is necessary to go into seclusion. If I did so in a natural manner, you would be suspicious of me. You would think that I performed things myself and made good use of my hands. Therefore, in order to convince you that there are certain other forces at work, I am going to have my hands, legs, my neck, and body tied to this chair. I want two members of the audience to come up and tie me securely. They may tie the ropes as tight as they wish, just so they do do not cause me any discomfort or pain as I must be free to concentrate on my work."



Have two gentlemen come up from audience. Lift up curtain on cabinet and turn it around to show that there is no one hiding. Then give each spectator a piece of rope about three feet long. Have each one tie an end of his rope around your left and right wrists, respectively. Allow ropes to hang down from your wrists.

Figure 30.

"As most of you know, the straight-jacket tie is one of the most secure ties known. It is what hospitals and asylums use to control raving maniacs or dangerous people. The arms are crossed and tied from behind, tight against the body. I want you gentlemen to tie my arms tight against my body in that manner."



Cross your arms in front of you and have spectators tie ropes behind your back.

Figure 31.



You may urge spectators to draw rope tight as you can keep wrists from going too far back. Thus ropes seem to be tight and yet you have enough play in your arms. Experience will teach you just how far arms should be crossed and how tight ropes can be.

Figure 32.

Sit down in chair and have ropes tied to upper part of chair back. Have ankles tied to legs of chair and then ropes brought up to bind knees to chair. A rope is also tied around waist and attached to chair back, and one around neck is also attached to chair.

Figure 33.



Have spectators lift you up with chair and place you inside of cabinet with chair close to back of cabinet. Then have spectators step aside while assistant takes charge.

Figure 34.



"Let me call your attention again to the secure manner in which two members of the audience have bound me—my hands, my legs, my waist, and head. I can sympathize with people bound in straight jackets. I will have my assistant take charge of things now to help me from the outside. Gentlemen, I shall ask you to examine the ties from time to time to see that I am always bound securely just as you have bound me. I will have the curtain drawn in front of me long enough for a manifestation, then it will be drawn aside."

Assistant places cane across your lap.

"Have you ever heard of the spirit of Katie King? Watch."

Assistant closes curtain quickly and steps aside. The moment curtain is closed, bring your right hand down and grasp cane. You will find that you can do this readily. Your hands seem to be tied tight, but in reality you can move them up and down. By twisting right shoulder to the right, you can easily pick up objects from lap.

Figure 35.

Hold cane by lower end so that you can bring crook up over top edge of curtain. Move it from side to side and finally toss it over curtain.



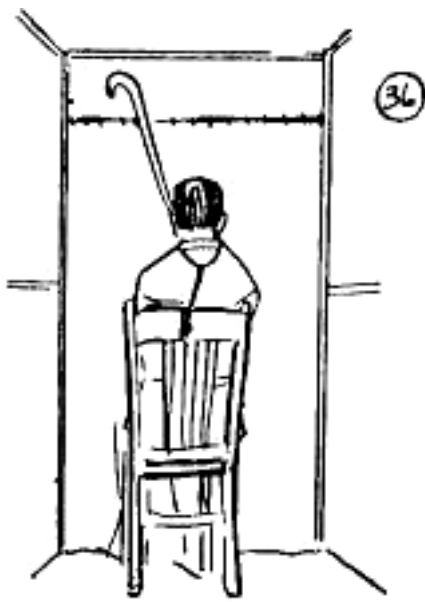
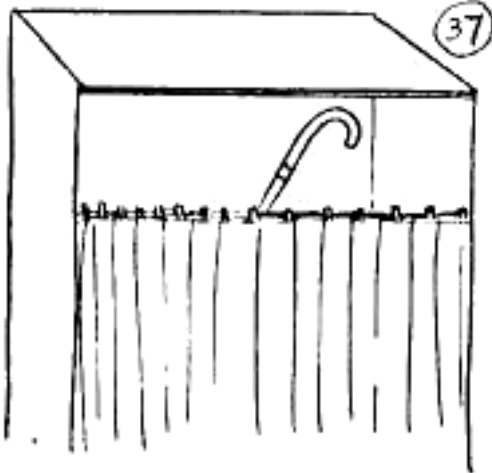


Figure 36 shows a view from the rear as you bring crook of cane up over curtain.



Audience knows you are tied and could not possibly lift the cane. They are baffled when they see cane apparently floating in air and believe some mysterious force is at work.

Figure 37 shows view from audience.

Quickly bring hands back to position. The moment cane is tossed out, assistant should draw curtains aside. Practice the timing of this well as there should be no hesitation. The more quickly this is done, the more mystified the audience will be. Some people swear they saw you tied while cane was flying through the air.

Assistant now places tambourine on your lap and on this, the bell -- then draws curtain again.

Reach down with left hand and grasp bell, lifting it from tambourine. Bring left hand with bell back into crossed position again. Then pick up tambourine with right hand. Jingle tambourine and ring bell at same time. Throw tambourine over curtain and follow it with the bell. Replace arms into position quickly again as assistant immediately opens curtain.

Spectators assisting are now asked to come into cabinet and examine the ropes. This done, they step out again and to one side.



Assistant places a glass half-filled with water on your lap. Curtain is closed. Reach down and pick up glass. Drink water. Tilt your head back and hold glass between your teeth.

Figure 38 shows a side view.

Curtain is pushed aside to show that water is gone from glass and glass is in your mouth.

Next, assistant takes a slate and shows it to be blank on both sides. He places it with a piece of chalk on your lap, and then closes curtain. Anyone in audience is asked to call out a question which he would like answered. Assistant repeats the question and you write some suitable answer on the slate. Curtain is opened and message shown on slate. To audience, you are still securely bound. You can close seance here or finish with a production.

You can easily arrange a production -- from a bunch of silks

to a bouquet of real or artificial flowers, or whatever your assistant could easily carry under his coat. Let us say he has bundle in a special pocket or apparatus under the right side of his coat. As he closes curtain after slate message has appeared, his back is to audience. He gets curtain close to him with right hand, quickly brings bundle out from under coat with left hand and tosses it into performer's lap. This takes only an instant and assistant continues closing curtain without hesitation.

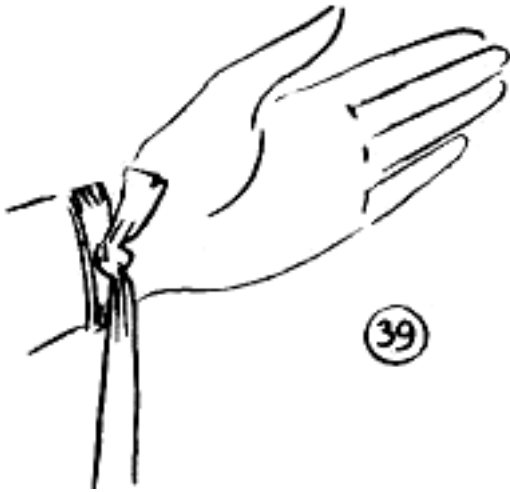
You arrange object in presentable shape. Assistant then opens curtain again and shows production. This adds a good bit of showmanship to the seance.

Have gentlemen examine the ropes and then untie you.

ANOTHER GOOD TIE

This is a modification of Anna Eva Fay's method of working, in which the hands are tied in back of the body and then to a chair. In spite of this, you have free use of your hands to accomplish manifestations.

This tie can be done with soft clothesline or tape. Strips of soft muslin are usually used and were preferred by Anna Eva Fay herself. The strips should be about two inches wide and about two feet long.



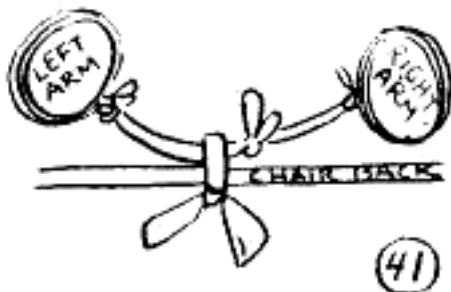
Have gentleman from audience wrap one end of strip twice around your left wrist and tie it securely. Knot should come on inside of wrist. If desired, melted sealing wax could be placed on knot. Have right wrist bound in same way with another strip.

Figure 39.



Place hands behind back and have the ends of both strips tied together, keeping your wrists about 9 inches apart. To do this, interlock your fingers and spread your wrists as far apart as you can. You face audience while this is being done so that they believe your wrists are being tied tight together.

Figure 40 shows a rear view.



Sit down on chair and have assistant run another strip of cloth around strip between wrists, keeping it on left side of knot. This strip is then tied to back of chair.

Figure 41 is a cross-section diagram of arrangement of strips.

Have spectator tie your ankles to chair, your knees together, and a strip around your neck to upper chair back. To the audience, it appears that you are securely bound.

Figure 42.



When curtain is closed, it is easy for you to reach article in your lap by sliding your hip over to the left on the chair and reaching around your right side with your right hand. Left hand goes as far around the back as possible to give right hand more play.

Figure 43.



It is easy for you to get back to original position again so that gentlemen assisting can examine the ropes at any time. You can work very quickly with this tie and get back into position again easily.

* * * * *

THE THROW-AWAY COAT TIE

This has been popular with stage performers -- among them, Houdini, Carter, Blackstone, Percy Abbott.

EFFECT:

Performer has his hands tied with a piece of tape behind his back. He steps behind a screen or curtain for a moment, tosses his coat out, and immediately comes out with his hands still tied. He then steps behind screen again and gets his coat on in an instant while hands are securely bound.

This makes a good effect to use before the Cabinet Seance. It gives a good excuse for working without your coat if you care to do so. After your coat is off, tapes are cut away, and then you proceed with seance.

MODUS OPERANDI:

Take a piece of black tape about half an inch wide and about two feet long. Have one end tied around your left wrist and the other end tied around your right wrist. This leaves about a foot of tape between your wrists. Do not have tape wrapped around wrists more than once. Also while right knot is being tied, keep tape between wrists taut. This makes right knot a SLIP KNOT.

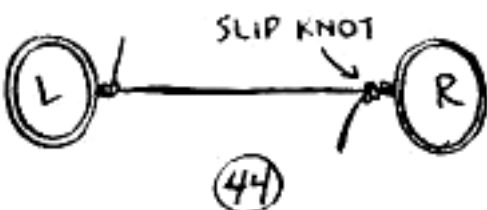


Figure 44.

Experience will teach you that when tapes are tied in this manner, right knot is a slip knot.

Figure 45 shows rear view after hands are tied.



Stand facing audience near curtain on stage or screen. As you talk to audience, you slip the right knot down and get right hand free of tape, leaving loop for wrist. Step behind screen or curtain or into cabinet. Quickly remove your coat and throw it out. Immediately put right wrist back into loop of tape and tighten it.

Come out and turn back to audience to show hands still tied.

Figure 46.

If you desire, you can step behind curtain again and put coat on quickly. Speedy work is essential in this tie.



Harlan Tarbell

TARBELL SYSTEM, INCORPORATED, Chicago.

* * * * *

The paraphernalia described in this lesson can be obtained from the Tarbell System at the following prices, postage prepaid.

Siberian Chain \$1.00

* * * * *

LESSON 47

EUGENE LAURANT'S LINKING RING ROUTINE.

The linking ring experiment has been popular for many years, yet only a comparatively few magicians have mastered the rings. Laurant's routine is one of the best in the profession. We are very fortunate to get this routine from Mr. Laurant as he charges a big sum to teach it personally.

Also -- HERMAN L. WEBER'S (NAMREH) EMERGENCY ROUTINE.

This is an excellent routine with four rings to puzzle those who try to catch you off your guard. Weber has specialized in Linking Ring effects, and his manuscript, "Lincoln Rings," is one of the best pieces of writing on the subject.

CHINESE LINKING RINGS

The Linking Rings is one of the oldest tricks and one of the most wonderful if presented in a finished and skilled manner. Audiences have been amazed for years by this effect of linking and unlinking solid steel rings. I well remember the time when I saw Ching Ling Foo, the celebrated Chinese conjurer, present the effect years ago. He made a masterpiece of the trick.

While a set of linking rings can be found in almost every magician's stock of apparatus, very few performers have ever mastered the routine well enough to present the effect with showmanship. The usual presentation is mediocre and lacks finish. The few men, however, who have studied the rings closely and have mastered the work with them, have made of them a thing of beauty. The work of these few men makes them stand out in sharp contrast to the ordinary performer of linking ring effects.

Eugene Laurant is one of those magicians who has spent years with the rings and in his hands the effect is a classic. It is a rare privilege for me to be able to give you Mr. Laurant's own routine with the LINKING RINGS.

Mr. Laurant's routine is the result of years of study and of experience. He has used dozens of variations, but he discarded them all and settled down definitely to using only those which he found most effective in his hands. His routine is snappy, just the right length, and full of showmanship. When he finishes, his audience is all worked up and a storm of applause is his unfailing reward. If you have not already had the pleasure of seeing Mr. Laurant perform, I hope that you may see him soon.

The student of Magic should study closely the ways of the successful professionals. The things to watch lie in their manner of presenting effects, rather than in the effects themselves. See how they eliminate unessentials and constantly play up strong points with a punch -- see how they avoid needless and monotonous repetition, but play up repetition with force when it strengthens the mystery and better pleases the audience. Watch these points in working with Linking Rings.

Handling the rings is not difficult, but it requires practice. You must become so accustomed to handling them that you can follow the routine almost automatically. You must be so familiar with them that one move blends into another--and this comes only through practice. You must have the ease of working so well in hand that your mind is left free for putting the effect over with SHOWMANSHIP. Mr. Laurant says that he makes it a habit to run through his linking ring routine before each performance to keep it fresh in his mind so that he can work at high pitch.

In this lesson I give you the complete routine and also the Patter which Mr. Laurant uses. It is impossible to give

you his remarkable Showmanship, but I hope you will work up the effect for yourself with real Showmanship.

The usual set of Linking Rings consists of Eight Rings. Mr. Laurant uses Eleven, and the routine is taught to you with that number.

* * * * *

EFFECT:

Ten steel rings are linked together and unlinked in a most mysterious manner. Various designs are then formed with the linked rings and interesting combinations are worked out. The final amazing effect is accomplished by linking all the rings together to form a cross of steel. Then the Magician links all the rings on one ring and suddenly unlinks them one by one and drops them to the floor.

PARAPHERNALIA:

A set of eleven nickel-plated steel rings, each about eight inches in diameter. See Figure 1.

Three of the rings are linked together: A, B, C.

Two more rings are linked together: D, E.

Four separate solid rings: F, G, H, J.

Two so-called KEY rings: K, K.

These Key rings have openings in them, about 3/8 of an inch.

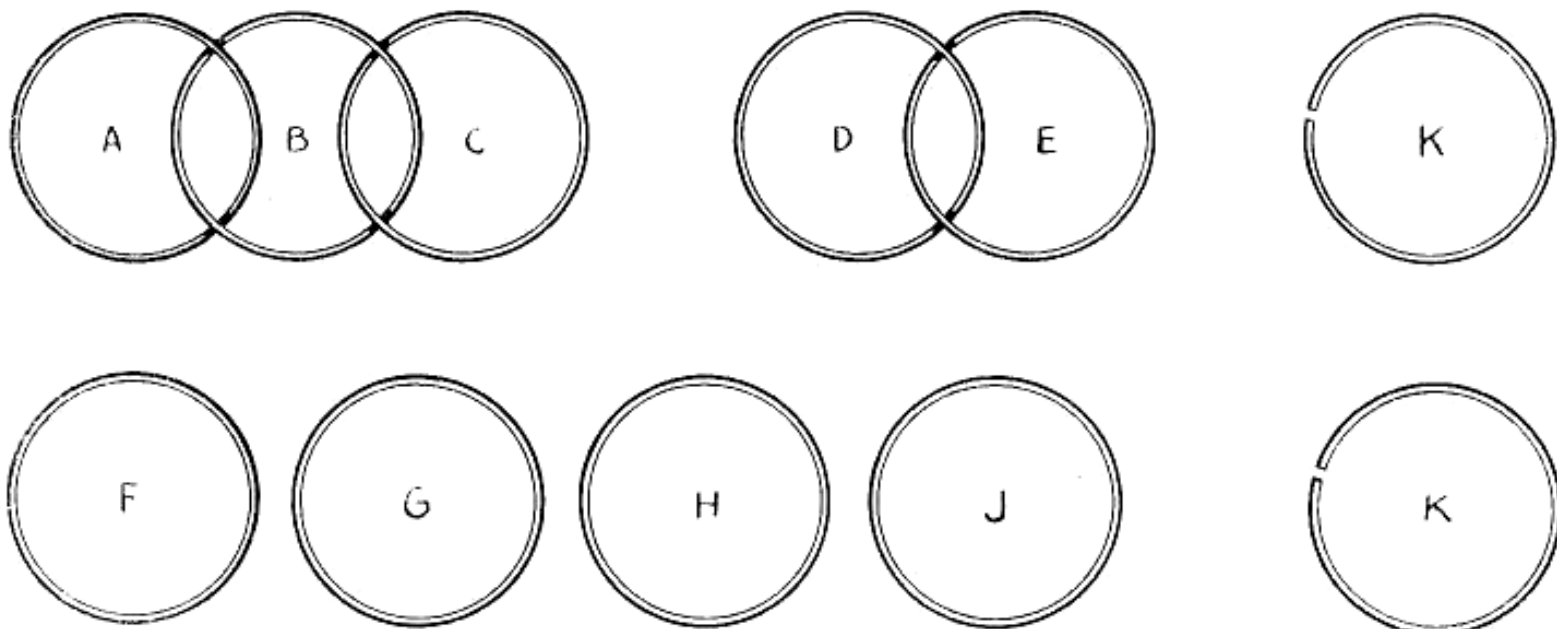


FIG 1

We can supply you with complete set of rings at reasonable price.

SECRET AND PATTTER:

To Prepare:

One of the Key rings must be concealed from audience. Mr. Laurant uses a special pocket sewed inside of right side

of his coat for this purpose. There is a snap fastener at the opening of pocket which keeps the Key ring secure in the pocket until it is needed. This can be unsnapped at a moment's notice.

Figure 2.



In case of emergency when Mr. Laurant is not prepared with his special pocket, he merely places his fountain pen in his regular inside right coat pocket and hooks the Key ring on to that.

Figure 3.



The remaining ten rings are then arranged on the table in this order: First, the other Key ring, (K) - then on top of that, the four single rings (F, G, H, J) - then the three linked rings (A, B, C) - and finally, the two linked rings (D, E). These should be squared up to look like a pile of single rings. Figure 4 shows the order of piling rings on table, starting with K.

To Perform:

With Key ring inside your right coat pocket, come forward with other ten rings in right hand. When you pick up rings from table to come forward, have the top of the pile -the two linked rings - against crotch of right thumb and Key ring toward tip of thumb and fingers.

Figure 5.



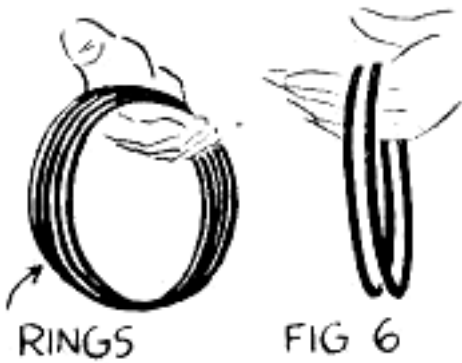
Take Key ring with left hand and place it down on table. This leaves nine rings in right hand.

"I am often asked the question, 'What do you consider to be the oldest known trick to Magic and Magicians,' and I always answer, 'Perhaps the Linking Rings of China.' It may therefore not be out of place here to relate to you a little legend told regarding these rings.

"Centuries ago in China, a priest in the temple made a chain of links of steel or copper or perhaps brass - we know not of just what metal - to suspend a lamp -- the lamp of life - and this lamp hung directly over the altar. Now, the old priest of the temple, with his followers gathered about him, would lower the lamp, remove it from the chain, and place it upon the altar. Then he would take the chain, made of these huge links of steel, and separate them. one from the other. His followers noticed that he had no difficulty in doing this, and though they examined these links of steel again and again, they could find no opening of any kind in them.

"The story soon spread about and pilgrims came from far and near to see the man who could take links of steel – put them together and take them apart – when they were solid with no opening in them. There is no doubt in my mind that this old priest of the temple wanted to impress his! followers with the fact that he possessed mystic power. In presenting this problem myself, however, I say the phenomenon is due only to natural law. Let us look the rings over."

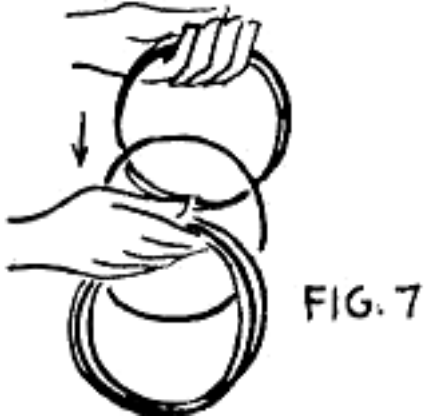
(47-3)



To show the rings separately, merely pass them from the right to the left hand. Pass the first three single rings with the hands about 12 inches apart.

Figure 6.

Decrease the distance between your hands and pass the rings faster when you come to the linked rings. If you pass these properly, they will appear to be single rings. Practice this move carefully before your mirror.

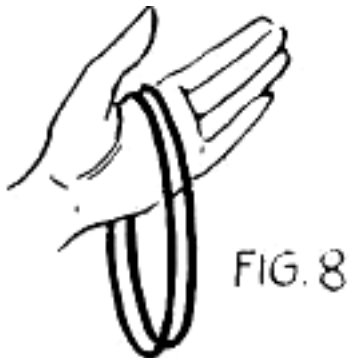


After all rings are in left hand, drop them one at a time back into right hand. Keep left hand a little above right hand but close enough to it to catch rings quickly. Be careful not to let linked ring drop to bottom of ring it is linked in. With a little practice, you can make the illusion of showing separate rings perfect. Make your movements as natural as if you were really showing all to be separate rings. You can put a little emphasis on showing those rings which are separate.

Figure 7.

You must leave a definite impression with the audience that the rings are separate. While showing them, say:

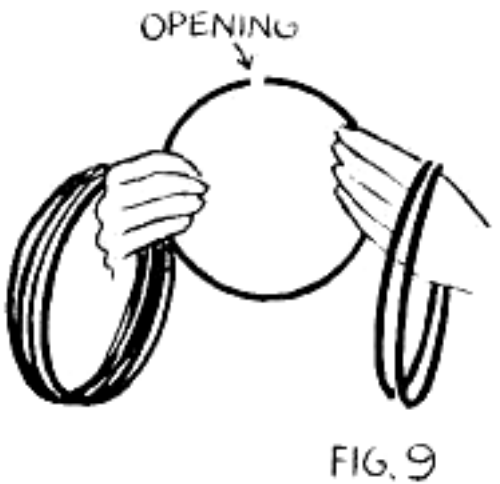
"We find that the rings used in the chain of the lamp in the temple are all separate and distinct, one from the other. First, let us prove that the rings I use are genuine in every way. The best test for steel is SOUND. We will test first with two rings."



Take two of the single rings in your left hand. Move hand up and down to make rings strike each other and jingle.

Figure 8.

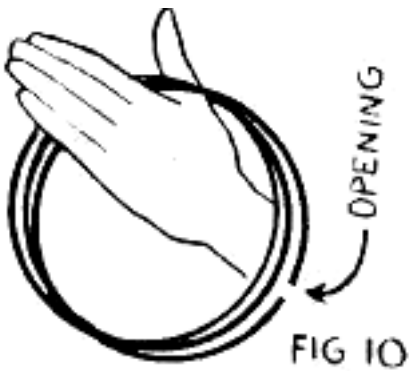
"They sound as clear as a bell."



Pick up Key ring from table and hold it with opening at top between your hands.

Figure 9.

"Here we have a faulty ring. I had it cut apart to show you the vast difference in sound between a ring with an opening in it and a solid ring."



Place ring on left hand with two solid ones. Shake the rings this time just to get a clattering noise in direct contrast to the jingle of the two solid rings before.

Figure 10.

"You hear a clattering metallic sound now -- not like the clear, bell-like jingle of the solid rings. Were I to use a ring with an opening, you could detect it immediately by its dull, clattering sound. WE CANNOT USE SUCH A RING so we shall throw it away."

(47-4)



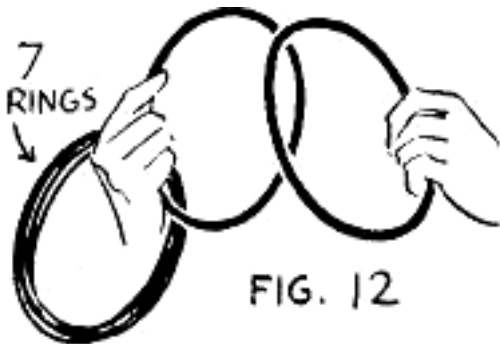
Throw the ring to one side or to back of stage.

Figure 11.

This is SHOWMANSHIP. You are convincing your audience that a ring with an opening cannot be used and you discard such a ring.

If there is a Magician watching you perform, he will be puzzled. He is accustomed to using Eight rings, consisting of three linked rings, two linked rings, two single, and ONE Key ring. He will sit up and take notice when he sees you throw away your Key ring. So you see, in this effect you interest not only the average audience, but those who may have read a solution for Linking Rings and even those who have performed with the rings.

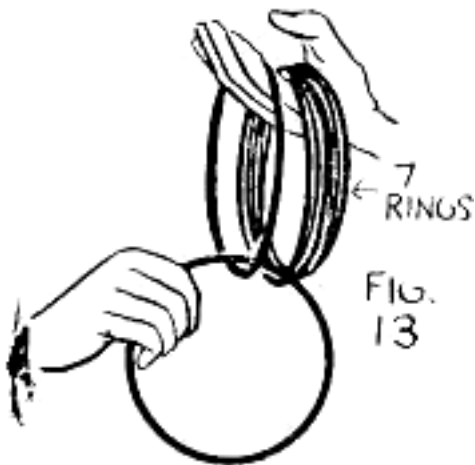
"We must use clear-sounding rings of solid steel just as the priest of old used."



Strike the two single rings from your left hand together.

Figure 12.

Now square up all the rings in right hand and transfer them to the left. If properly held, they look like a bunch of single rings.



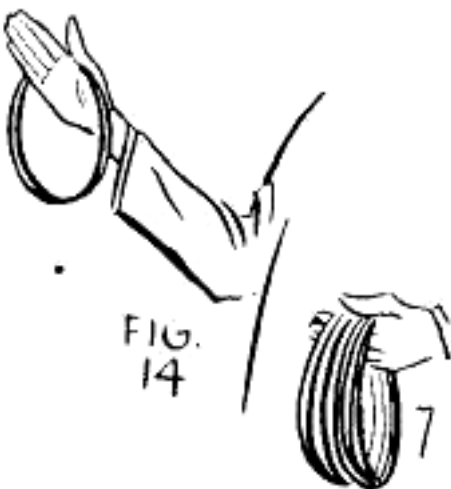
Suddenly allow the outer ring, toward tips of fingers drop. This ring is one of the two linked together, and it will drop to the bottom of the other ring in which it is linked. Spin ring quickly with right hand. This adds action and dash to your presentation.

Figure 13.

"Behold, we have two rings suddenly linked together."

Take the two linked rings in right hand and dangle one from the other to show that they are linked.

"Immediately, you say to me, 'Do you mean to say that you can take two perfectly solid rings and actually link them together?' Well, the proof is in the sound. Let us try whether they are solid or not."



Jingle the two linked rings together in the right hand to bring out the clear bell-like tone.

Figure 14.

"You notice that the sound is the same as the sound of the solid rings you heard before."



Drop one of the linked rings in right hand so that it will hang suspended from the other ring. Then transfer bunch of rings from left hand to right hand, leaving two single rings in left hand. Jingle these two rings together to show similarity of sound.

Figure 15.

(47-5)



FIG. 16 Figure 16.

Place bunch of rings back on left hand, leaving the two linked rings in right hand. Jingle these two rings again to show clear sound.



Allow ring D to slip over right wrist. Look at bunch of rings in left hand, and suddenly let ring B drop from the three linked rings in left hand. Spin ring B with right hand.

Figure 17.

"Let us try it again. Two more rings link themselves together."

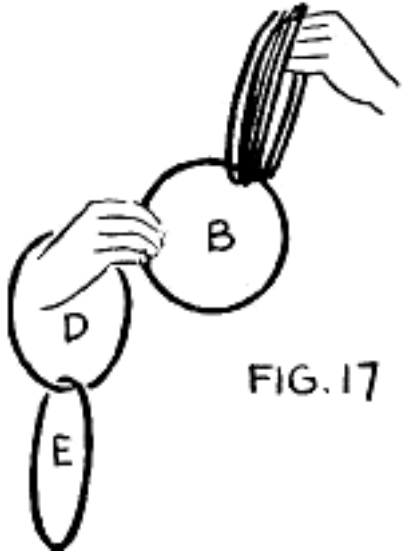


FIG. 17

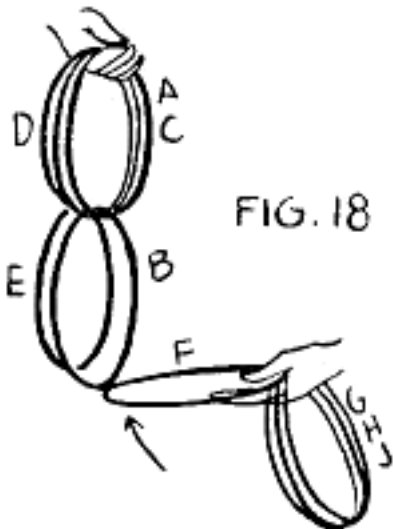


FIG. 18 Figure 18.

Transfer the three linked rings -- A, B, C -- to right hand. Strike ring B with one of the four single rings from left hand.

"And they ring true."

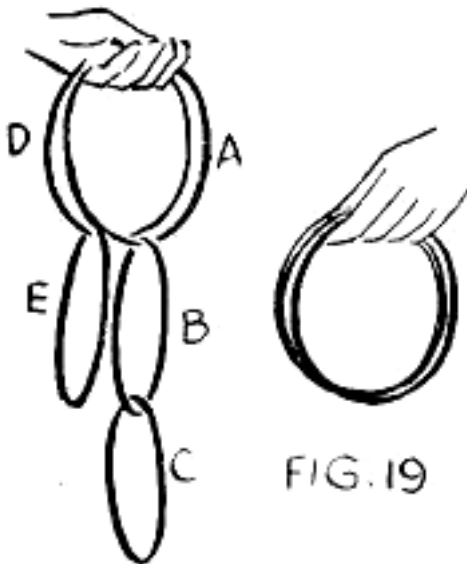


FIG. 19

Drop ring C, which falls to bottom of ring B and forms a link of three rings.

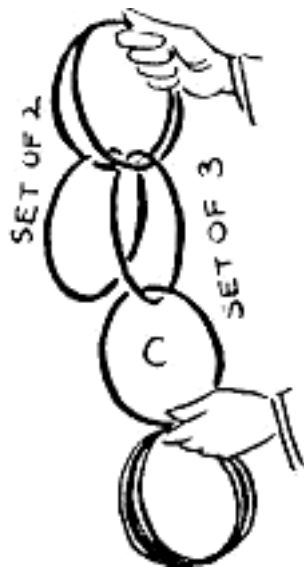
Figure 19.

NOTE: This routine with three rings is easy if you arrange them properly in the beginning. Experience will help you in working them. However, should ring B not be the one to drop down first, do not let it worry you. A or C can drop first and then B, and you will get equally satisfactory results.



"Ah, now we have five rings linked together. The linked ones are no different in sound from the single ones."

Hold rings as in figure 20--linked rings in right hand and four single rings in left. Jingle first one bunch and then the other.



With left hand grasp bottom of ring C.

Figure 21.

Bring ring C upward so that the three linked rings stretch from left hand down to right. Right hand holds rings A and D together as though they are linked.

(47-6)

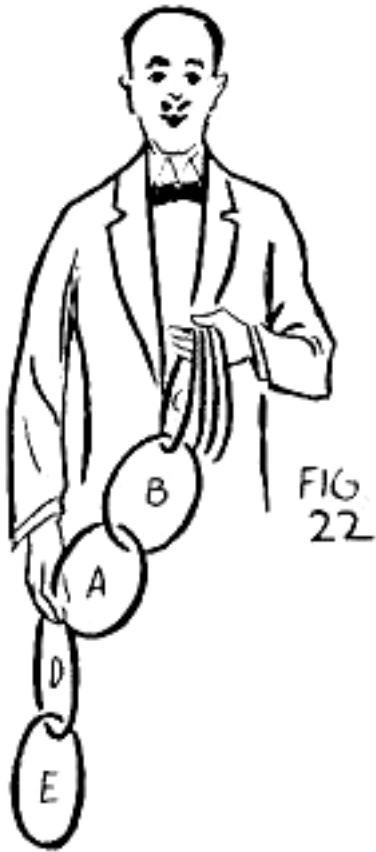
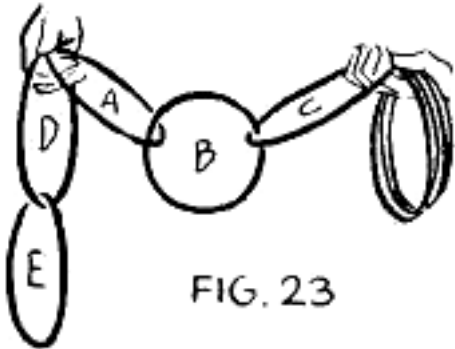


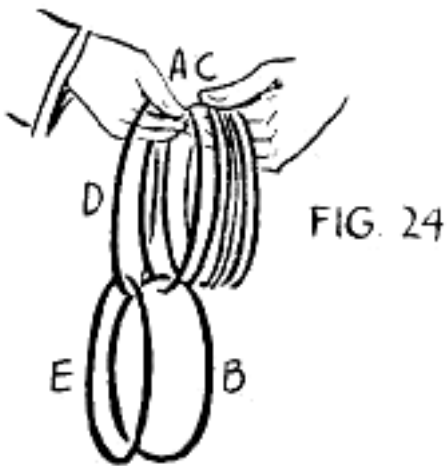
Figure 22.

"A chain of five. You see them—but perhaps a better way to convince you is to let you take the rings and thoroughly examine them."

Leave stage and come down to audience.



Now bring right hand up with ring A on a level with ring C in left hand. Hold rings as in Figure 23.



Bring two hands close together. This brings rings A and C next to each other. This is preliminary to pulling apart apparently ring A from ring D.

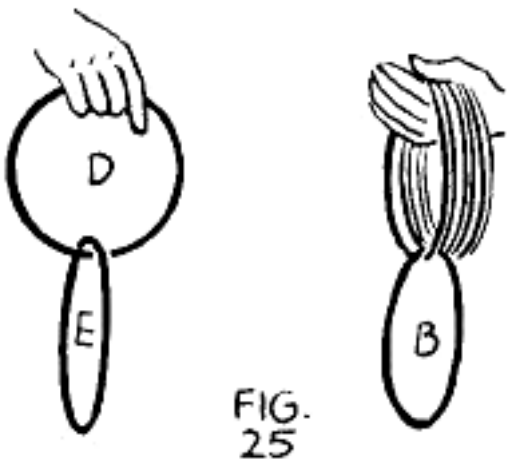
Figure 24.

Say to a spectator at your right:

"Please look at these rings, sir."

As spectator starts to take hold of chain of rings, say:

"One moment, let me separate a couple so that our friend over here may see them also."



Apparently disconnect ring D from A by giving it a sudden jerk. Then hold the two linked rings--D, E--in right hand and the three linked rings--A, B, C--with four single rings in left hand.

Figure 25.

"Two for you -- and three for you."

Give D, E to one spectator and A, B, C to the other.

"Would you like to examine a ring, too, sir?"

Give one single ring to another spectator.

"And you, sir?"

Give another ring out for examination.

"And you?"

Give a third single ring to spectator.

"And, sir, here is the last one."

(47-7)

Give fourth ring out.

"I want you all to examine every one of the rings carefully before I collect them. You will find that each ring is as solid as it can be and as strong as it is possible to make them with steel."

After allowing a few moments for examination, collect the three linked rings, squaring them up in right hand -- then the two linked rings, squaring them up with the three in right hand.



At this point, stop a moment and face audience.

Figure 26.

"Last night a young man explained this trick to a young lady sitting next to him in the theater. He said, 'You watch that magician when he gathers up the rings. He will start for the stage, and as he turns around, he will exchange the rings in his hand for some others which he has hanging on his back under his coat.' "



As you say this, turn quickly toward stage to illustrate your meaning. When your back is turned, slip the Key ring from your inside coat pocket on to your right hand with rest of rings.

Figure 27.



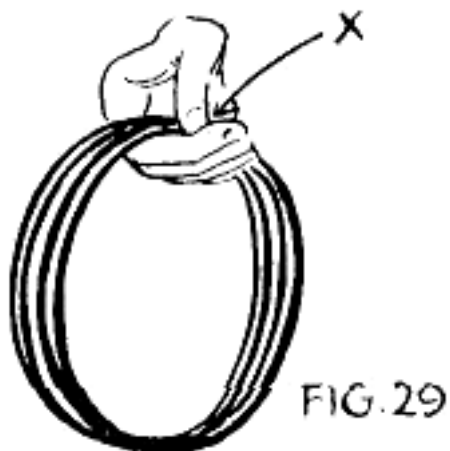
Bring all the rings in right hand up over your right shoulder.

Figure 28.

"Imagine me carrying a bunch of rings on my back."

Turn to face audience.

"I hope you do not accuse me of such nonsense. Will you please touch one of these rings, sir?"



Hold rings in right hand toward spectator, turning the Key ring slightly toward him. Be careful to cover opening in ring with thumb and fingers of right hand.

Figure 29.

Spectator will, in most cases, touch ring nearest to him -- the Key ring. Regardless of which ring he touches, however, you turn the bunch of rings in toward your body and take Key ring in left hand.

Give bunch of linked rings from right hand to a spectator to hold.

"Please hold these rings for a moment. This gentleman has selected a ring for me to use. I find it a good one."

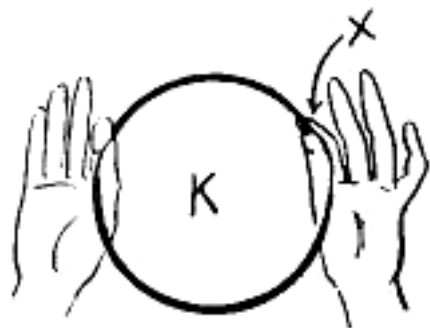


FIG. 30

Hold ring up, with thumb and finger of left hand covering opening X. Right hand is in same position on other side of ring. Expose palms of hands to audience.

Figure 30.

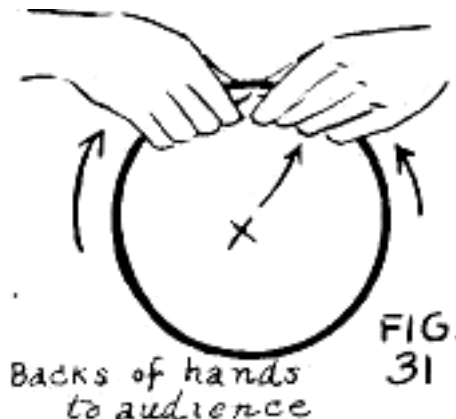


FIG. 31

Close left hand over ring. To give effect of revolving ring to show it solid all around, hold ring tight with left hand and bring hand upward. As you do this, close right hand over ring.

Figure 31.



FIG. 32

Now bring left hand downward, holding opening X tight. As ring turns, slide right hand over ring downward until hands are in position shown in Figure 32.

Perform this move about three times. Practice it well in front of your mirror. Notice how deceptive the move is in giving the appearance of actually revolving the ring several times.

"Now, if you who are holding the other rings up the aisle will hold them in this manner, I will try to make a chain for you, linking the rings together as you hold them in your hands, right before your eyes."



FIG. 33

Show spectators holding single rings how to grasp them. Demonstrate with your own ring, grasping it with both hands close together at the bottom.

Figure 33.

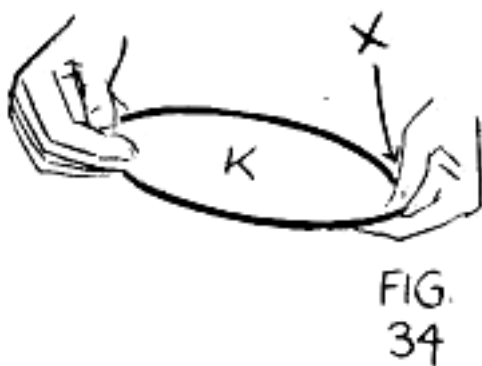


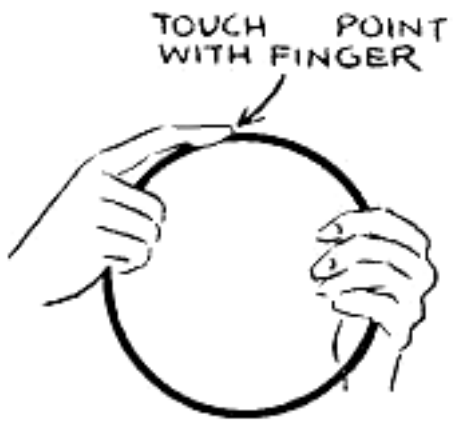
FIG. 34

Now come forward and ask another spectator to touch ring at any point. Hold ring toward him as shown in Figure 34, carefully concealing opening X.

"Touch this ring anywhere you like, sir."

Spectator will usually touch side of ring nearest to him at a point between your hands. If he touches other side of ring, merely reverse ring, bringing this side to front.

"Thanks. Now, please notice this point. I shall place my fingertip near it to mark it."



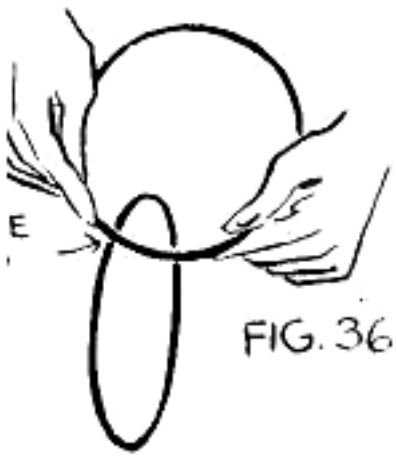
Place tip of right index finger at selected point on ring. Then place finger-tip just back of this point, raising it and replacing to accent point.

Figure 35.

"I will connect each ring just at the point the gentleman has touched. Watch!"

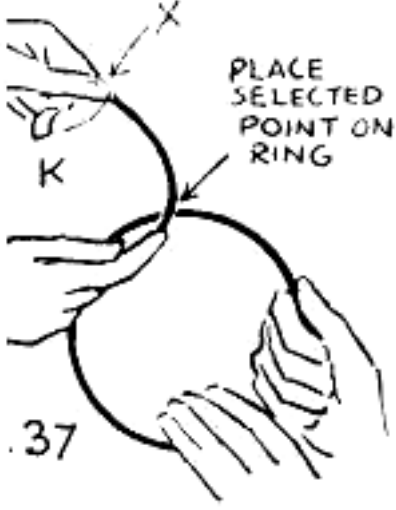
(47-9)

FIG. 35



Walk up to one spectator holding a single ring. Strike your ring against his at the selected point.

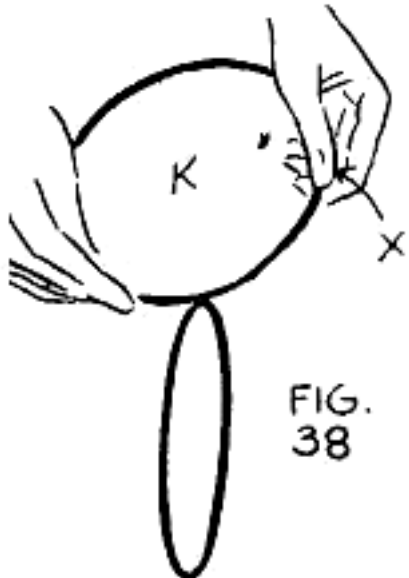
Figure 36.



Place your ring against his again at selected point. Be careful to conceal opening X in left hand and tilt left side of ring upward a little.

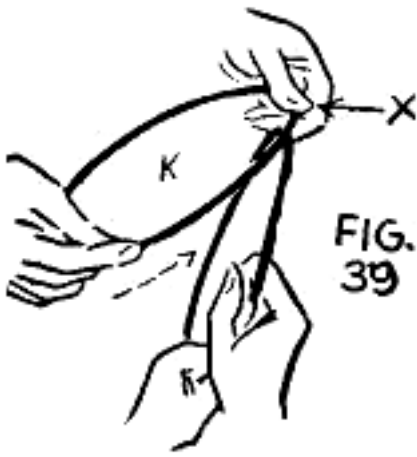
Figure 37.

"Hold your ring tight, sir."



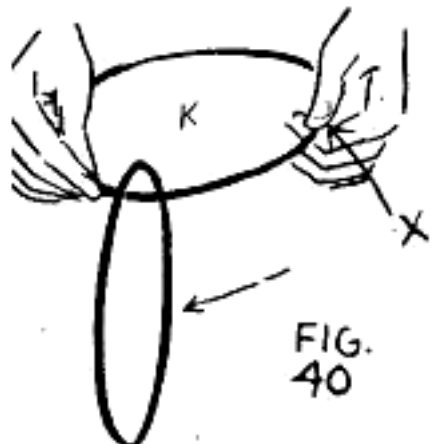
Now strike his ring again WITH YOUR RING HELD AT ANGLE OF 45 DEGREES, slanting down from left hand.

Figure 38.



With your ring at an angle, the blow causes spectator's ring to be forced suddenly to the left near the opening X of your ring.

Figure 39.



Spectator's ring automatically goes into opening in your Key ring and comes back to selected point, linked in your ring. Release opening from left hand just enough to permit penetration of other ring and then conceal it again in left hand. The illusion is that spectator's ring penetrated your ring at selected point.

Figure 40.

Figures 41 and 42 gives another view of this movement.

You are holding opening X in left hand and indicating selected point with right index finger. Your ring is on a slant downward from the left hand. As you strike spectator's ring at selected point, his ring is pushed suddenly to the left, slips into opening X, is linked in your ring, and comes back to selected point at tip of right index finger.

This all happens so quickly that the illusion of penetration AT SELECTED POINT is perfect. THIS IS A VERY IMPORTANT MOVE, AND, IT ALONE, IS WORTH MANY DOLLARS TO THE MAGICIAN PERFORMING LINKING RINGS. Practice it well until you absolutely master it. You will be well repaid for your time and effort.

(47-10)

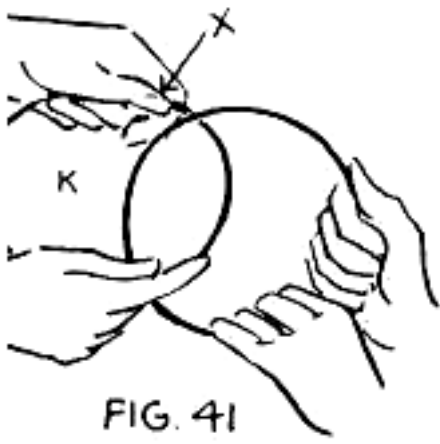


FIG. 41

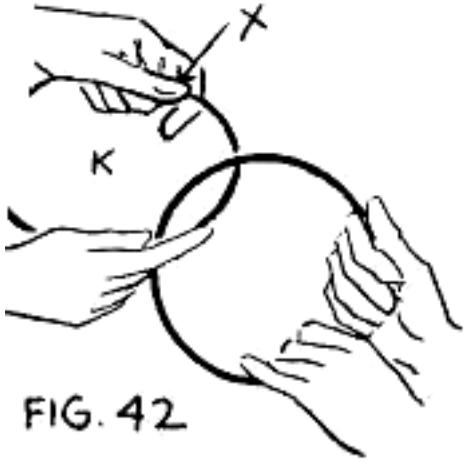


FIG. 42

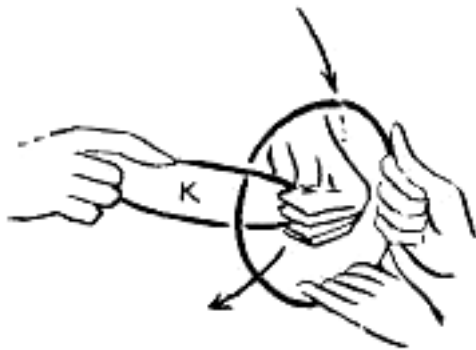


FIG. 43

Move your ring up and down through spectator's ring to show that they are actually linked.

Figure 43.

"The two rings are linked together at the selected point."



FIG. 44

The moment you have shown linking of rings, push your left hand through spectator's ring, taking ring away from him on your left wrist. Pass on quickly to another spectator holding single ring.

Figure 44.

"Hold tight, sir. Watch the point on my ring."

Raise right forefinger again and lower to indicate selected point.

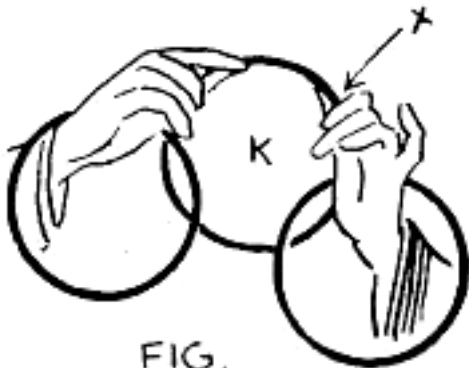


FIG. 45

Strike his ring at selected point, then raise your ring suddenly, strike his ring again and link it as you were taught to do. Quickly show rings linked and thrust your right hand through his ring. Carry his ring away on your right wrist.

Figure 45.

Continue linking the rings on until all four have been taken up. Take ring from third spectator after it is linked by passing your left hand through his ring. Take ring from fourth spectator by passing right hand through his ring.

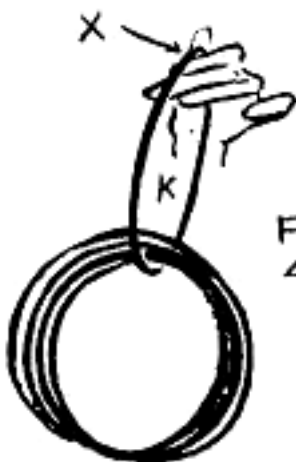


FIG. 46

Allow the four rings to fall to bottom of your Key ring, hanging from left hand.

Figure 46.

"Four rings I linked on my ring -- each at the point selected by the gentleman."

Spin the four rings on the Key ring. The noise and movement add action at this point.

Stop suddenly as though some spectator had said something.



FIG. 47A

"What! Why, of course, if you can put them on, you can take them off!"

Quickly bring the four rings up with right hand near opening X concealed in left hand.

Figure 47A.



Slip rings through opening X with aid of right hand.
Then drop them one at a time into right hand.

Figure 47B.

(47-11)



FIG.
47B

Instead of dropping Key ring, bring it down to right hand suddenly, giving the appearance of dropping it.

Figure 48.

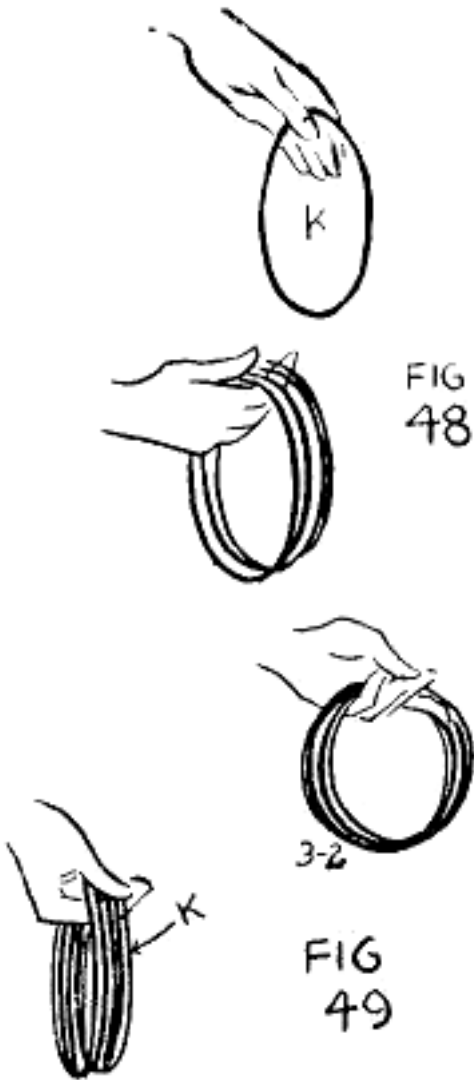


FIG 48

Hold the five rings in right hand. Take the five linked rings which a spectator is holding. First, take A, B, C and then D, E with left hand.

Figure 49.

"I will take the rings you have, sir."

Go back to the stage, and while your back is turned, perform the following moves quickly:

Study the diagrams closely.

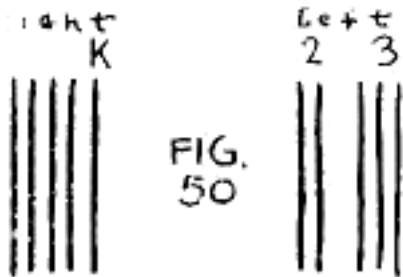


FIG. 50

Figure 50 shows the order in which you hold rings to begin with -- Four single rings in crotch of right thumb and Key ring towards tips of fingers; three linked rings in crotch of left thumb and two linked rings towards tips of fingers.

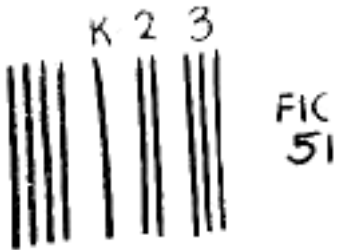


FIG 51

Bring your hands together so that Key ring in right is next to outermost ring in left.

Figure 51.

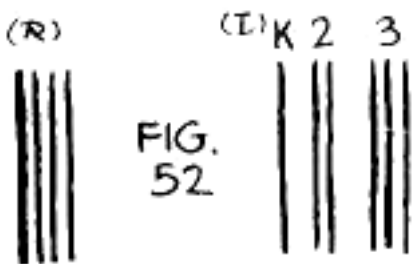


FIG. 52

Transfer Key ring from right hand to left.

Figure 52.



FIG. 53

Reverse position of rings in left hand so that Key ring is now in crotch of thumb. You will find this very easy to do by twisting your wrist and swinging rings around the opposite way.

Figure 53.

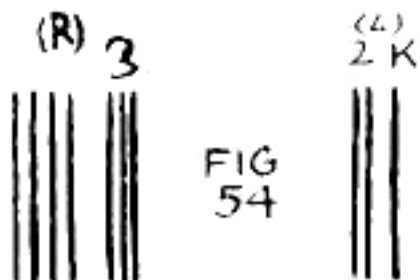


FIG 54

Bring hands together again and transfer three linked rings to right hand.

Figure 54.



Allow bunch of rings to slip over right arm. Slip one of the two linked rings through the opening X in key ring in left hand.

Figure 55.

(47-12)

FIG. 55

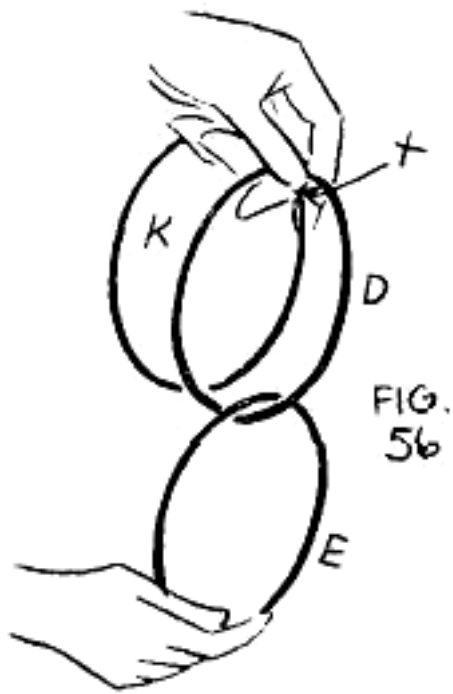


FIG. 56

Figure 56 gives you a close-up of what happens. You hold Key ring in left hand and hold two linked rings between your hands as you link one of these rings through Key ring.

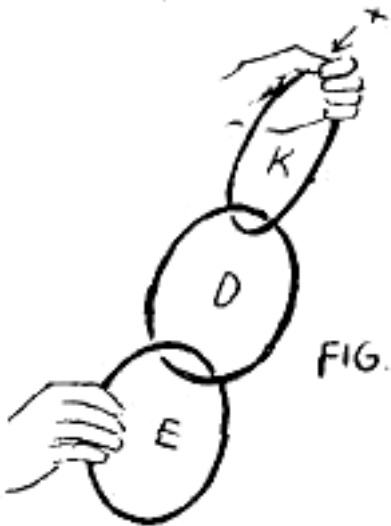


FIG. 57

Allow the two linked rings to hang down from Key ring. Turn to audience. To spectators it appears that you just put all the other rings over your right arm and are holding the three linked rings you just took from spectator.

Figure 57.

"I notice you were trying to pull these rings apart. You cannot take them apart by pulling. If you would like, however, I will remove one from the chain. Which one? The middle? All right."

Pretend that you heard someone call out the middle ring.

"In order to do this, the rings must not be jerked apart but must be put together."



FIG. 58

Study carefully how to perform the following moves. Grasp the middle ring with right hand.

Figure 58.



UNLINK -
MOVING
FROM
FRONT
TO
REAR

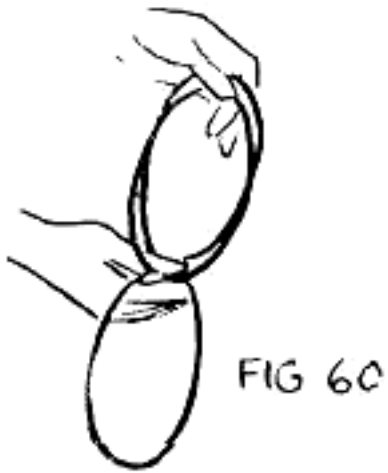
FIG. 59

Bring center ring up and pass it through opening in Key ring. Shift this ring from in front of Key ring to rear of it.

Figure 59.

Grasp bottom ring E at its joining with D with right hand.

Figure 60.

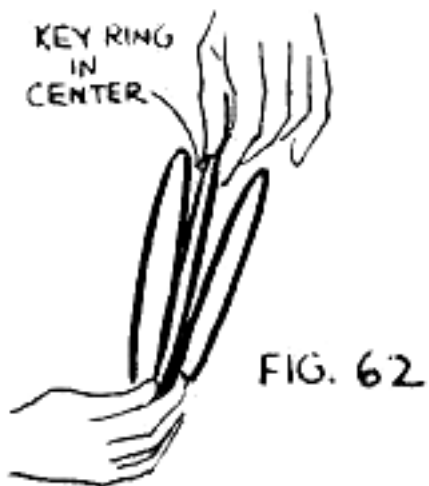


Revolve ring E upward so that bottom of ring comes up to left fingers. Now hold the three rings at bottom in right hand.

Figure 61.

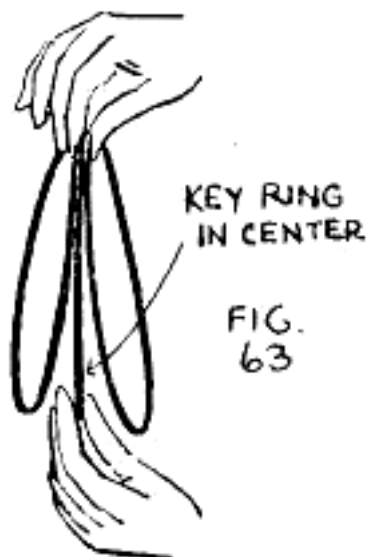


(47-13)



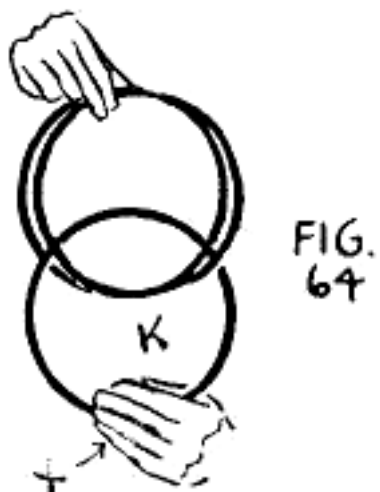
Grasp Key ring, which is now between rings D and E, with left hand.

Figure 62.



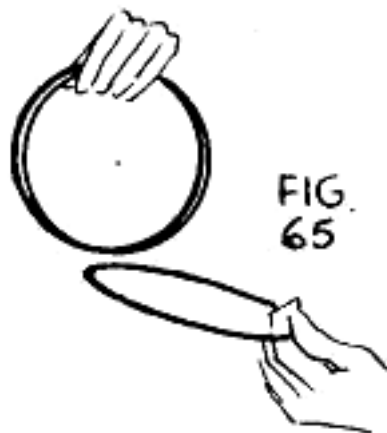
Bring right hand up and left hand down so that rings are in position shown in Figure 63.

"Then remove the middle ring this way."



Pull middle ring down slowly with left hand.

Figure 64.



Show this ring separately, then strike it against two rings in right hand.

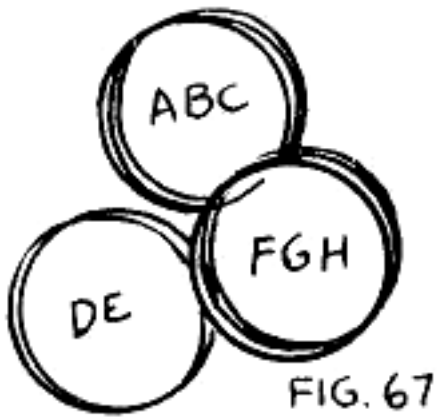
Figure 65.

"And put the other two together again."



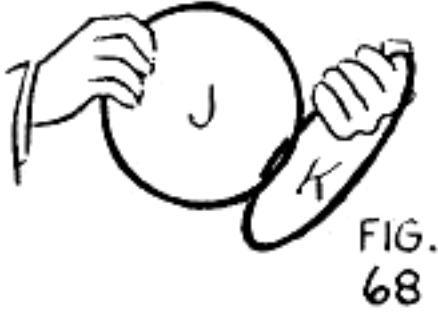
Drop one of the rings in right hand. It will fall to bottom of other ring, in which it is linked, with a noise. This pretended linking of the two rings is very effective.

Figure 66.



Now place eight of the rings on the table this way: The three linked rings -- A, B, C -- in one pile; the two linked rings -- D, E -- in another pile; and three single rings --F, G, H -- in a third pile.

Figure 67.



The two remaining rings are the Key ring, which you now take in your left hand, and a single ring, which you take in your right hand. Strike the Key ring against the solid ring. Then allow ring J to slip through opening in Key ring.

Figure 68.

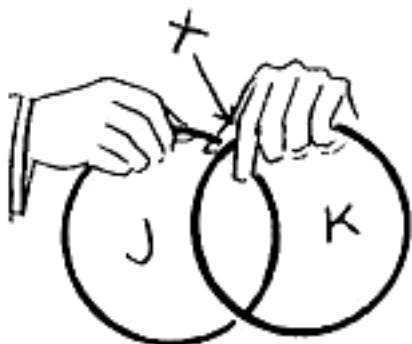


FIG. 69

Slowly move rings apart. Then suddenly let ring J drop, linked on ring K.

Figure 69.

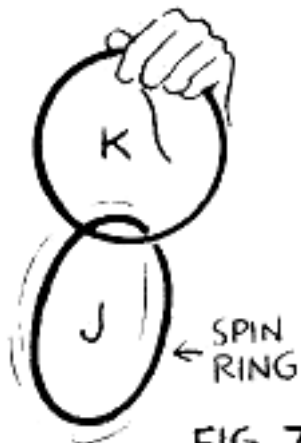


FIG. 70

The two rings are suspended from left hand. Spin ring J fast with right hand.

Figure 70.

"You see it is connected."

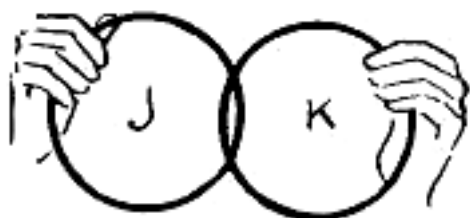


FIG. 71

Bring rings together again so that you can slip J through opening in K and unlink them. Then slowly move two rings apart. To the audience they appear to be linked still.

Figure 71.



FIG. 72

Bring rings to position shown in Figure 72 with edges touching as though they are linked.

"To remove it, I must find the identical place at which it was connected."

Pull rings apart suddenly.

"And thus, the rings separate easily. Let us take two others."

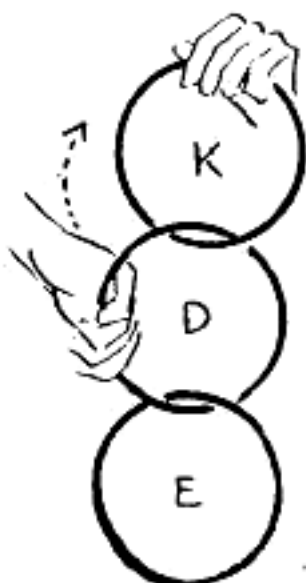


FIG. 73

Drop J on pile of single rings on table -- F, G, H. Link D onto K as you did J.

Grasp ring D with right hand. Palm of hand must face audience so that little finger is above.

Figure 73.

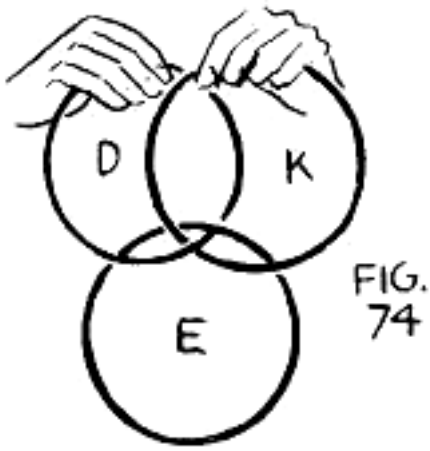


FIG. 74

Quickly bring D up beside K, turning backs of both hands to audience. This move so twists the rings that they come into position shown in Figure 74.

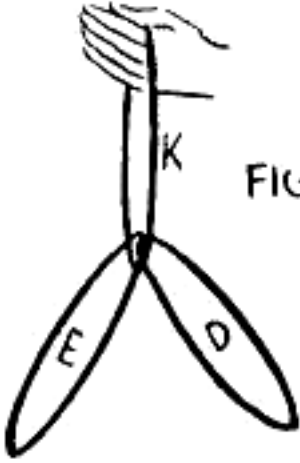


FIG. 75

Slip D quickly through opening in K from rear to front, and let it fall into position shown in Figure 75.

Swing the rings back and forth a little.

"Here we have a queer little figure."

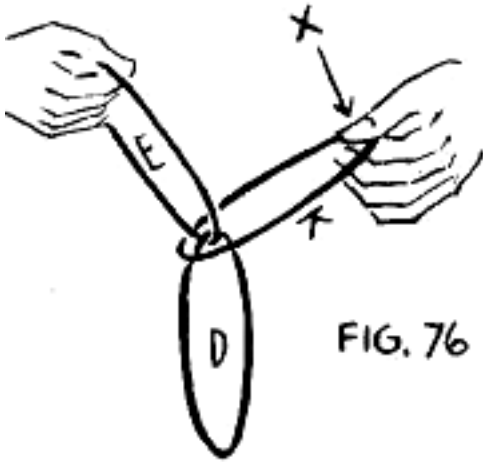


FIG. 76

Pick up E with right hand and lower K a little with left hand.

Figure 76.

(47-15)

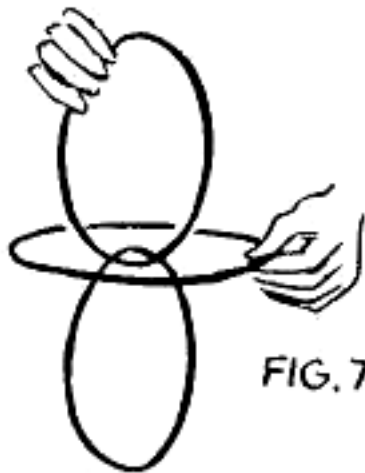


FIG. 77

Move K down so that it is between D and E.

Figure 77.

"An hour glass."

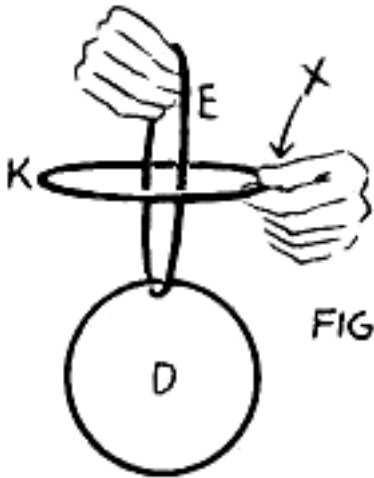


FIG. 78

Then bring K up to middle of E.

Figure 78.

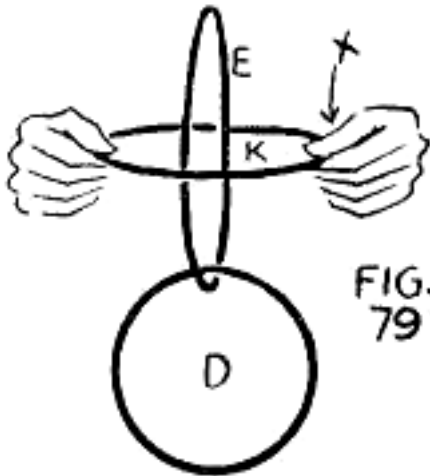


FIG. 79

Hold K with both hands and let E balance in it.

Figure 79.

"A gyroscope."

Bring rings together and unlink D and E from K. Place D and E on table.

Pick up A, B, C, holding them squared up together in right hand. K is in left hand.

"Let us make a longer chain."

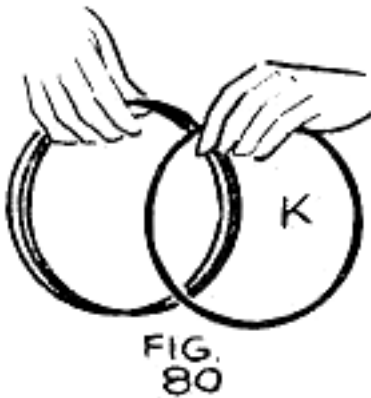


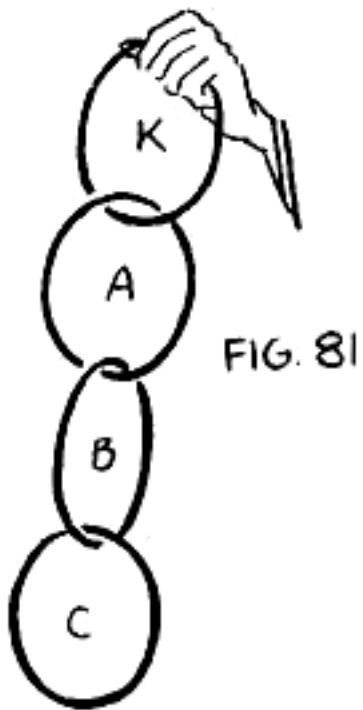
FIG. 80

Quickly link ring A into K.

Figure 80.

Give the rings a jerk, pulling them out of right hand and letting them fall suspended from K in left hand. It appears that you took four single rings and suddenly linked them into a chain.

Figure 81.



Put right hand through lower ring C from rear to front and turn ring to the left as far as it will go to show that rings are firmly linked.

Figure 82.

(47-16)

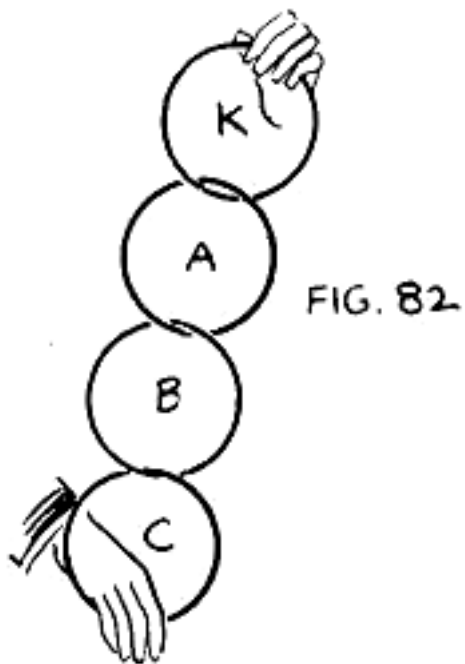




FIG. 83

Bring C up parallel with K.

Figure 83.



FIG. 84

Slip C through opening in K, allowing the rings to fall into the formation they take as shown in Figure 84.



FIG. 85

Figure 85 shows another view of this formation, called the Iron Knot.

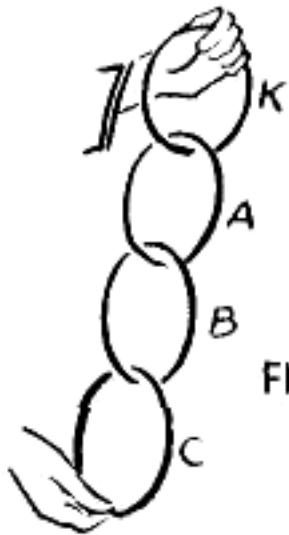


FIG. 86

"An iron knot."

Grasp C again with right hand and unlink the chain of rings. Hold between your hands as in Figure 86.

"Back to the chain."

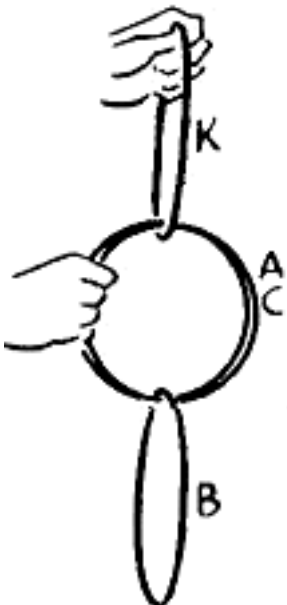


FIG. 87

Pick up bottom ring C again and link it through K. This brings A and C together with K above and B below.

Figure 87.



FIG
88

Grasp A and C with right hand and bring them up so that B and K fall together to bottom of these rings.

Figure 88.

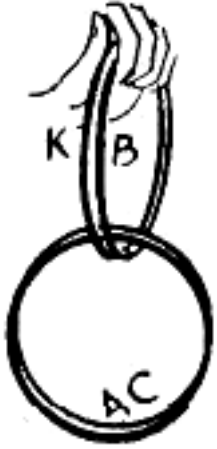


FIG
89

Grasp K and B with left hand and raise them, allowing A and C to hang from them.

Figure 89.

(47-17)

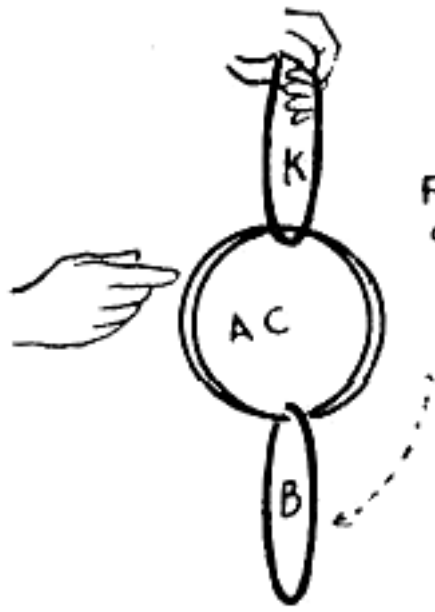


FIG. 90

"The two rings linked into two."

Pull rings to show that they are securely linked, holding B and K in left hand and A and C in right.

Now release B from left hand and let it fall to bottom of A and C. Hold the chain suspended from left hand.

Figure 90.

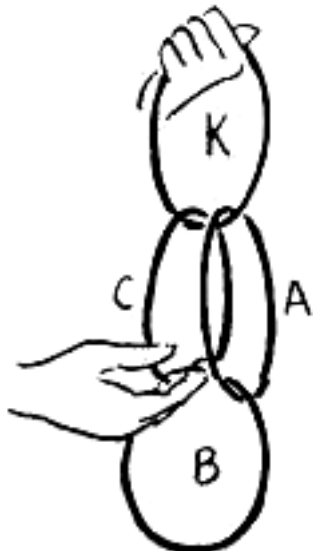


FIG. 91

With right hand reach in between A and C. Grasp top of ring B.

Figure 91.



FIG. 92

Pull B up and out to position shown in Figure 92. Remove right hand. Rings will remain in this position. Swing them in left hand, back and forth.

"A swing for one."



FIG. 93

Grasp B again with right and turn the formation horizontally. Hold rings up in front of face.

Figure 93.

"A baseball mask."



FIG. 94

Now bring rings down. Place B from right hand in left hand with K. The formation is shown in Figure 94.

"A globe."



FIG 95

Turn hand over, reversing position of the ring formation.

Figure 95.

(47-18)



FIG. 96

"A rose."

With right hand open upper part of formation a little.

Figure 96.

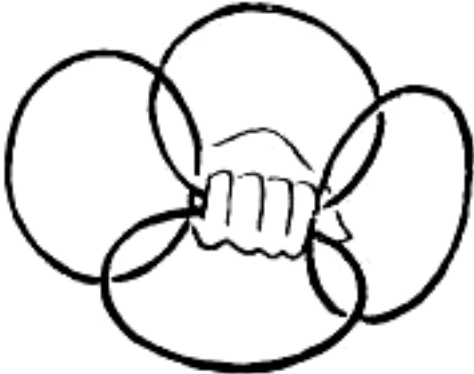


FIG. 97

Grasp rings firmly with left hand and allow them to open up.

Figure 97.



FIG. 98

"The opening of the rose."

Let rings fall over hand.

Figure 98.

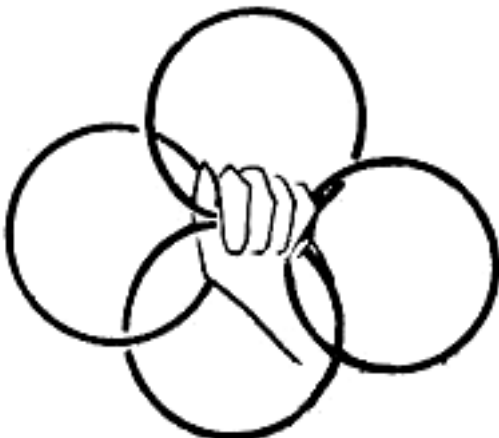


FIG. 99

"A round square."

Bring rings back into position shown in Figure 99.



FIG. 100



FIG. 101

"An iron cross."

Swing rings back to the closed rose formation as in Figure 100. Then back to the swing formation.

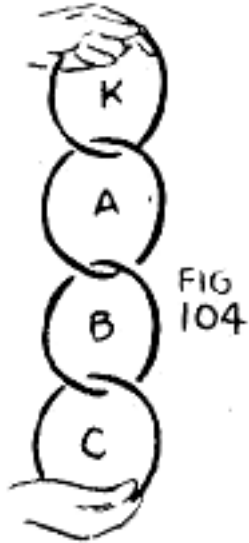
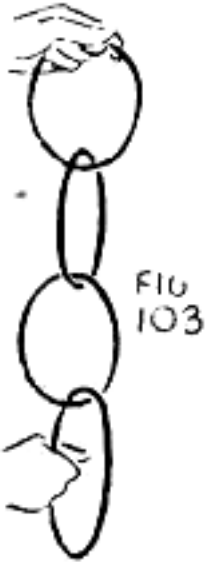
Figure 101.



"And back to the little swing for one. But the boys and girls seldom like a seat for one. Never mind"

Grasp outside ring with right hand and unlink it from Keyring.

Figure 102.



This brings the rings back to the chain formation. Rings are in this order: K in left hand, then A, B, C, linked in it. Chain is stretched between left and right hands.

Figures 103 and 104.

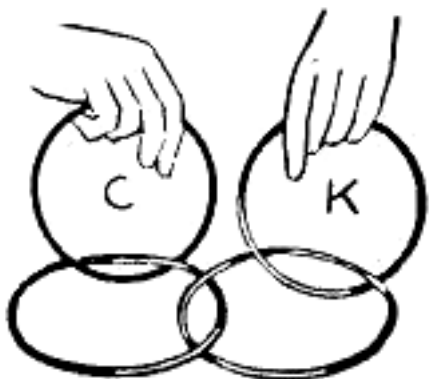


FIG 105

Twist rings again by grasping bottom ring C and turning it to the right as far as it will go. Then bring C toward K.

Figure 105.

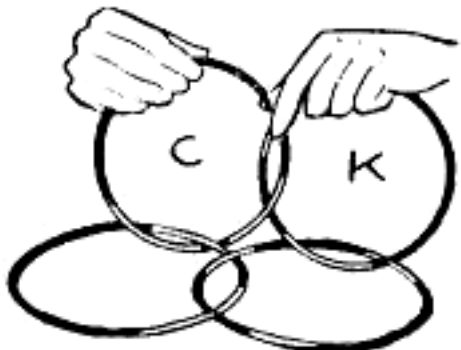


FIG.106

Place C a little back of K. This causes A and B to swing out toward audience and upward a little to make formation shown in Figure 106.

Swing this formation as you did the seat for one.

"We have a seat for two."

Drop C again to form the chain of four rings.

"Let us take two more rings."

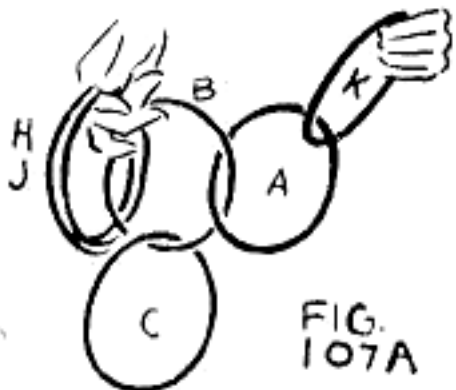


FIG. 107A

Pick up two single rings with right hand -- H, J. Also grasp B on chain of rings with right hand.

Figure 107A.

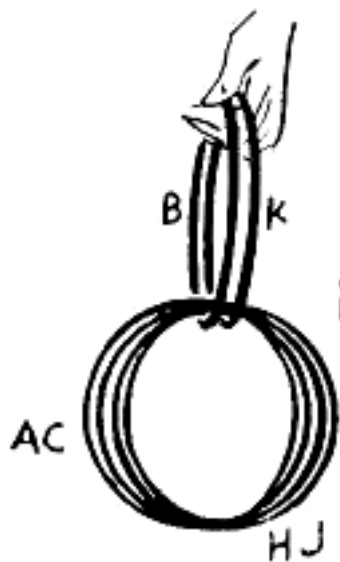


FIG. 107B

Link H and J on K, working from the rear to the front. Take B in left hand with K and let other rings fall to bottom.

Figure 107B.



FIG. 108

Shake the rings.

"Two rings holding four."

Drop ring B from left hand. Rings fall into position shown in Figure 108.

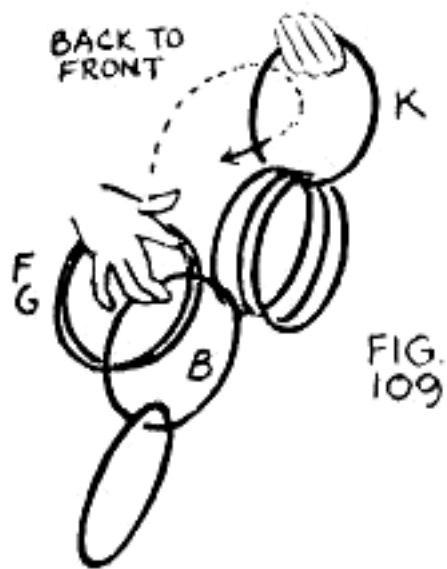


FIG. 109

"Again two more rings."

Pick up F, G -- two more single rings -- from the table with right hand. Grasp B again as you did before with right hand. Raise right hand with rings up behind K.

Figure 109.

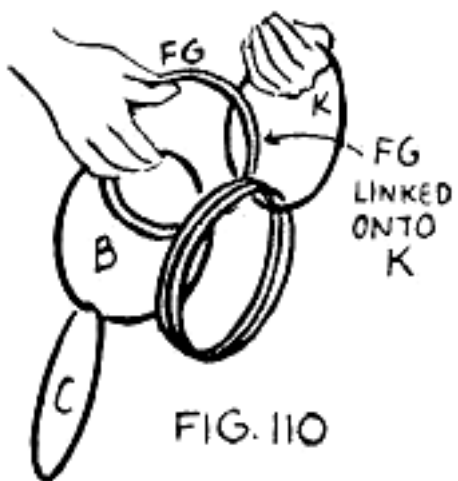
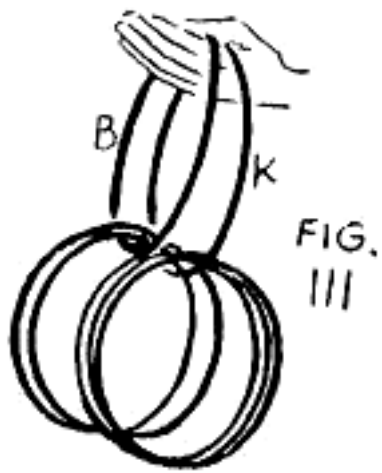


FIG. 110

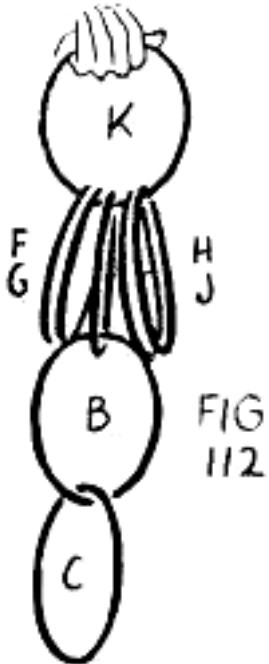
Link F, G through K. Grasp B with left hand.

Figure 110.



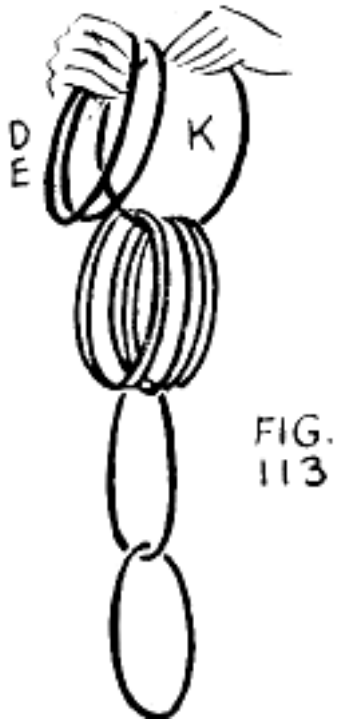
Holding rings suspended from B and K in left hand, shake rings vigorously.

Figure 111.



"Six rings linked into two."

Drop B. this gives you the formation shown in Figure 112.



Pick up the two linked rings -- D, E -- with right hand and bring them up to K.

Figure 113.

Link one of these rings on K - let us say, D. Raise E up with right hand above K. Keep your grasp over opening in K with left hand.

Figure 114.

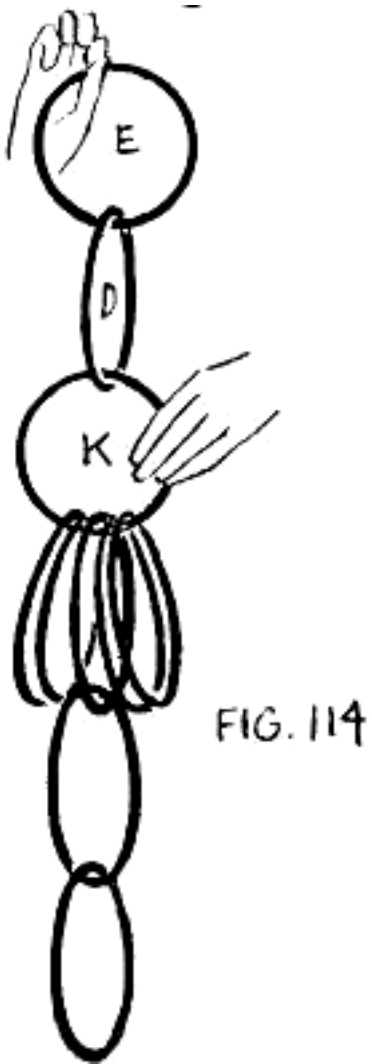


FIG. 114

Place ring E in your mouth. Separate F, G and hold on right side of K with right hand. Put your left hand through H, J and grasp K at opening with left hand.

Figure 115.

(47-21)

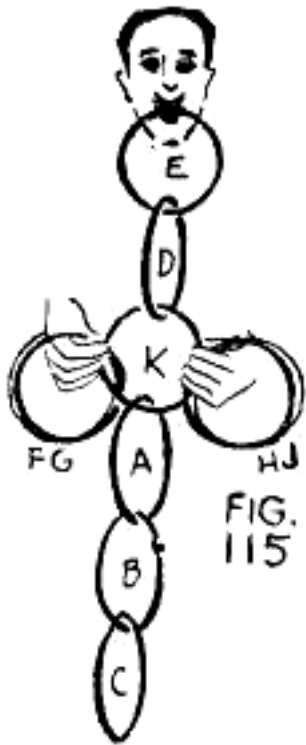
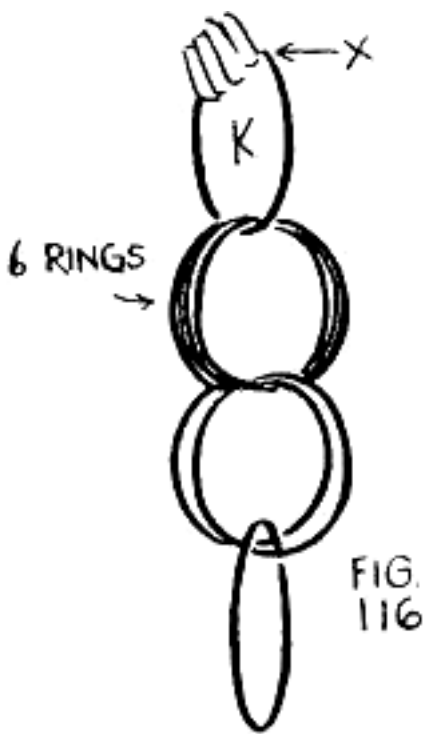
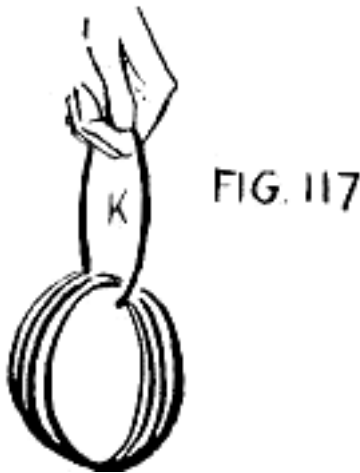


FIG. 115



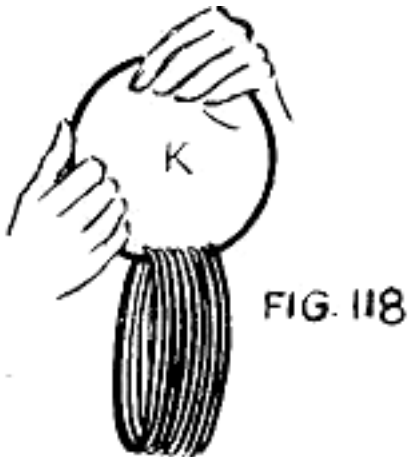
"A cross of steel."

Hold K up in left hand, allowing D, E to fall down from Key ring. Rings now give formation shown in Figure 116.



Now move the rings up and down vigorously in the air, and with help of right hand, get all the rings linked on the Key ring.

Figure 117.



"All the rings linked upon one."

Spin rings with right hand.

Grasp Key ring with right hand. With left hand turn ring to bring opening to bottom just above rings linked on K.

Figure 118.

Shake Key ring up and down, allowing the rings to fall to the floor one at a time.

Figure 119.

"And finally, under the Magic spell, they fall one by one to the floor."

Finally, drop the Key ring down with the others, just as the last solid ring falls. Because of the bunch of rings on the floor and attention drawn to you, the Key ring will not be noticed.

As Key ring falls, raise your hands upward at your sides and bow slightly for your Finale.



FIG. 119

NOTE:

Be sure to pick up rings immediately or have your assistant do it, getting the Key ring after the first few solid rings.

In linking and unlinking rings, be careful to keep the movement well covered with left fingers so that opening is never exposed to audience.

You have a fine routine here with the rings. Practice faithfully until you get every move as nearly perfect as possible. Then study SHOWMANSHIP and put so much into your work that you will bring the house down with applause when you perform with Linking Rings.

* * * * *

WEBER'S EMERGENCY ROUTINE

This is the ring routine used by Herman L. Weber (Namreh), eminent magician and author of "The Lincoln Rings." This routine is simple and is very useful in an emergency for no key ring is used. This is just the thing to work on the fellow who gives you two solid rings to link or a couple of linked rings to pull apart. Weber has specialized in ring effects for years and his routine for emergency work is truly welcomed.

EFFECT:

Performer shows four single rings, then taking two in one hand and two in the other, links them together -- two within the other two. Suddenly he pulls them apart again. He links two of the rings, one inside of the other, and places the two single rings over the top of a chair. The two linked rings in his hand are pulled apart, and when the two single rings are picked up from chair, they are found to be linked together. Rings are then passed out for examination.

PARAPHERNALIA:

- 1 -- Two single linking rings.
- 2 -- Two rings linked together.

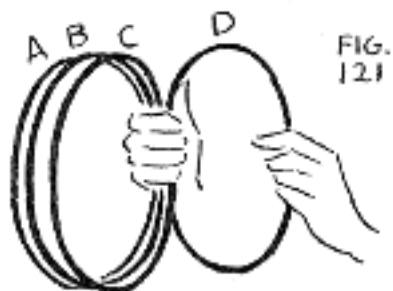
SECRET:

To Perform:



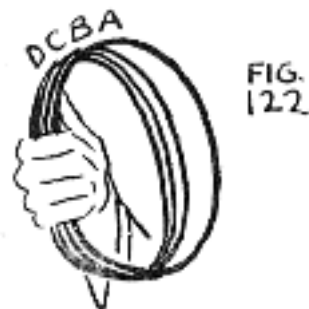
Let A and B represent the two single rings and C and D, the two linked rings. Pick up A, B, C, D together and hold the four rings in right hand.

Figure 120.

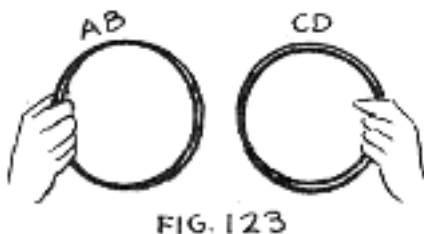


Start counting rings with left hand, grasping each ring and pulling it back to right wrist or forearm.

Figure 121.



When you have finished counting, rings are held in right hand as shown in Figure 122.



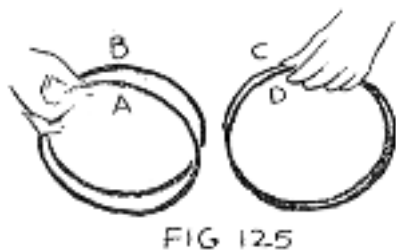
Take single rings A and B in right hand and linked rings C and D in left hand.

Figure 123.



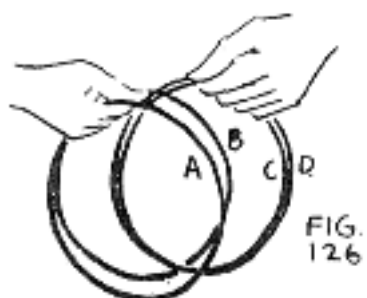
Slap AB in front of CD and in back of CD.

Figure 124.



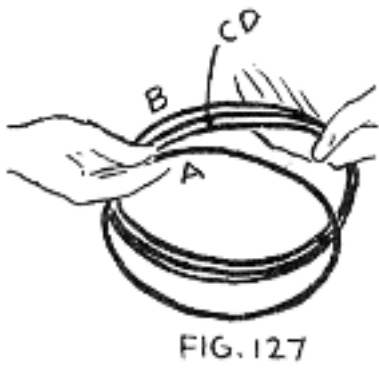
Now push right thumb between A and B and bring separated rings toward CD.

Figure 125.



Push rings CD between AB.

Figure 126.



Grasp rear ring B in left hand together with CD. Three rings are now held by left hand and one by right. Keep rings close together.

Figure 127.

(47-24)

FIG. 127



FIG. 128

Grasp outer ring C in right hand with A. Then release C from left hand and pull C and A away together with right hand, leaving B and D in left hand.

Figures 128 and 129.

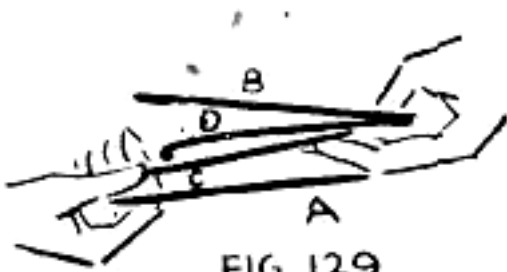


FIG. 129

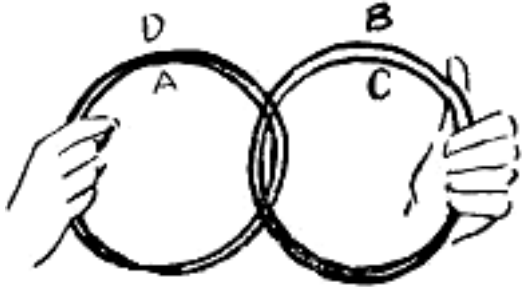


FIG. 130

Rings now appear to be linked together as shown in Figure 130.

The routine from Figure 125 to 129 should all be done as one continuous movement. Rings should then be pulled smartly apart resulting in the effect that all four rings have been linked together. Be sure to hold AC firmly with right hand and BD close together with left.



FIG 131

Reverse movements, going from position shown in Figure 129 to 126. Then separate rings with a graceful easy motion as if dissolving rings through each other. Hold rings as in Figure 123 and immediately drop CD on left arm.

Figure 131.



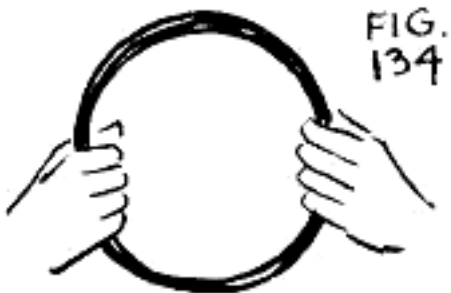
FIG 132

Throw A and B from right hand, one at a time, on to left arm. For Showmanship hold both hands obliquely upward here and make a momentary gesture.

Figure 132.

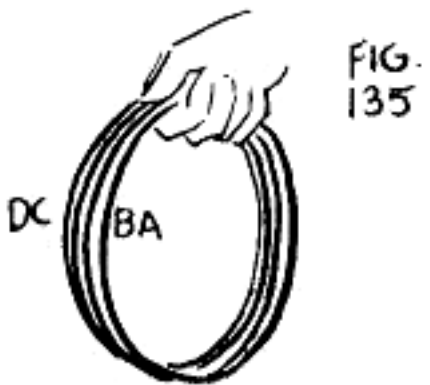
Allow rings to slide from left arm to left hand.

Figure 133.



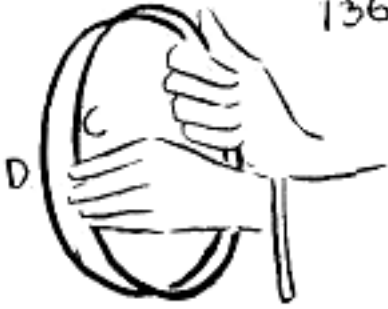
Swing left hand toward the right and grasp opposite side of rings with right hand. Single rings A and B are now to rear and backs of hands are toward audience.

Figure 134.



Transfer rings to right hand. Rings are now held as shown in Figure 135. CD are toward palm of hand and AB are toward tips of fingers.

FIG
136

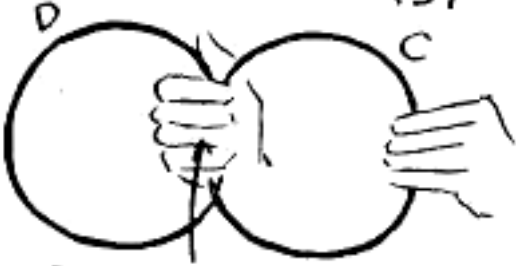


Now throw A and B together on to left arm as you did with C and D before. Hold CD in right hand in position shown in. Figure 120.

With left fingers draw C away from D to spread rings open.

Figure 136.

FIG.
137



Open rings straight out, still keeping right hand over joining of the two rings.

Figure 137.

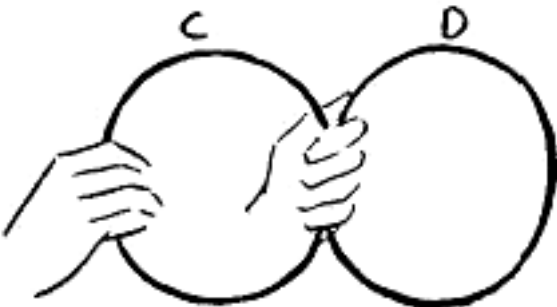
RIGHT HAND ACTS
AS HINGE AND
CONCEALS JOINT

FIG.
138



With right hand acting as a hinge, pivot D over in front of C and grasp opposite side of both rings with left hand.

Figure 138.



Now grasp rings firmly in left hand, and with right hand open C out toward the right. This time left hand acts as hinge and covers the joining of the two rings.

Figure 139.

FIG. 139

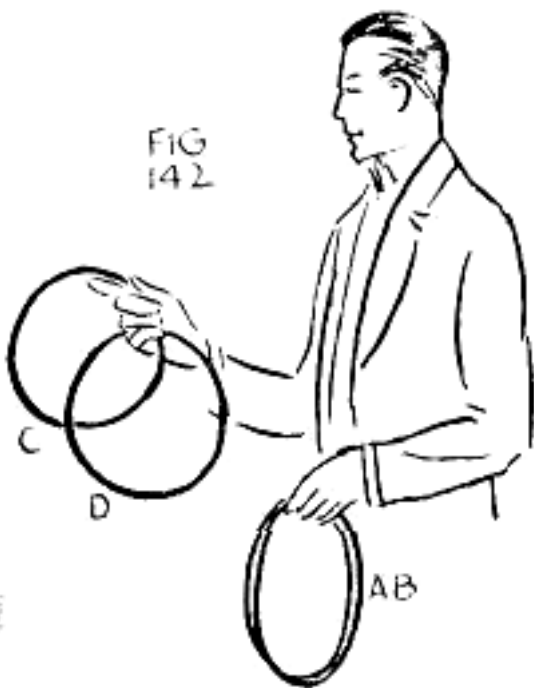
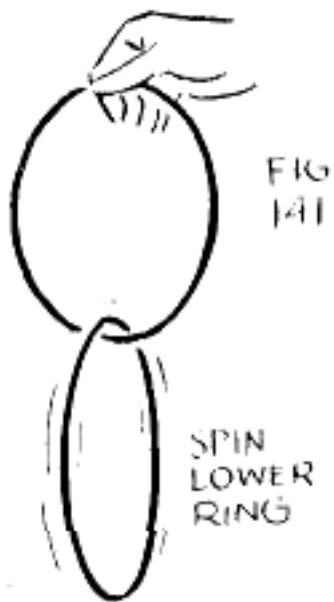
FIG
140



With left hand pivot D over in front of C and take rings with right hand, and hold as shown in Figure 140.

Release one ring from right hand with a sharp motion downward and backward, throwing one ring into the other with a clang. Spin lower ring with left hand.

Figure 141.



Pass CD out for examination. When they are returned, take them in your right hand, slipping little finger between the rings and rest of hand on edge of top ring. While calling attention to CD, slip AB down to left fingers.

Figure 142.

(47-26)



FIG. 143. Hold single rings A and B in left as shown in Figure 143. Fingers are toward yourself, back of hand to audience.



FIG. 144

Secretly insert two middle fingers between the rings, leaving the index and little fingers to hold the ring nearest you.

Figure 144.

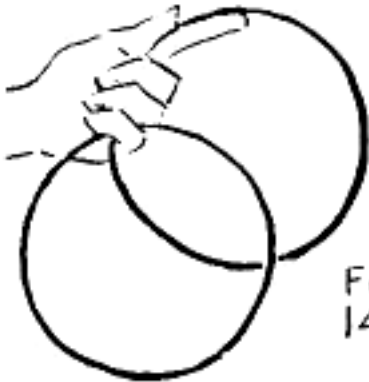


FIG 145

Draw forefinger out from under both rings, causing one ring to fall downward a little and hang suspended from little finger. Insert forefinger again under edge of upper ring. These rings are now held in position similar to those in right hand.

Figure 145.



FIG. 146

Turn body to left, bringing right side to audience. Allow CD in right hand to come together as AB spread apart in left hand. This takes place while you are turning to left and rings are close together in front of body.

Figure 146.

To audience it appears that you have changed rings from one hand to another, transferring single rings to right hand and linked rings to left. Drop rings CD on to chair. These are the linked rings from right hand, but audience believes them to be the single rings. They look like single rings as they hang on chair.

Figure 147 and 148.

FIG
147

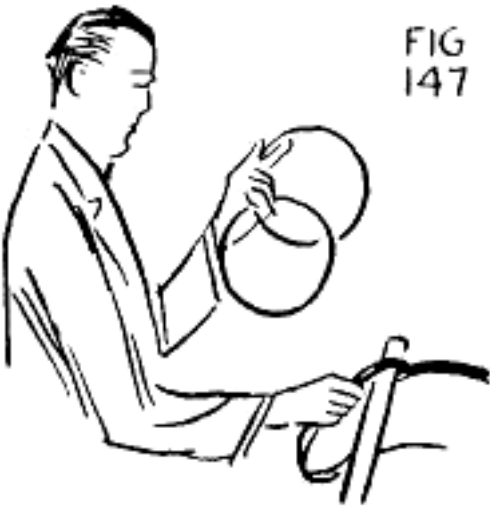
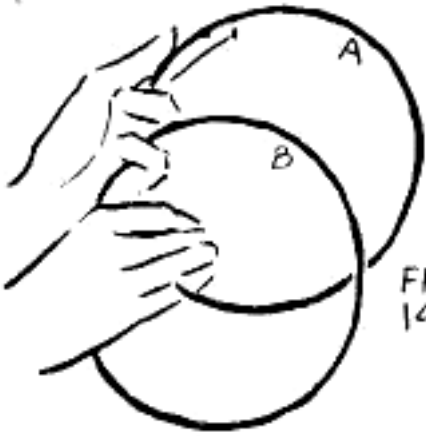


FIG.
148



Grasp AB with right hand, placing little finger under lower edge of A and rest of fingers around side edges of A and B.

Figure 149.

FIG.
149

Bring hands and rings to horizontal position. Figure 150 is a view from above, showing positions of hands. Fingers of left hand are upward and back of right hand is upward. B is released from little finger of left hand so that left hand grasps only the outer edge of A.

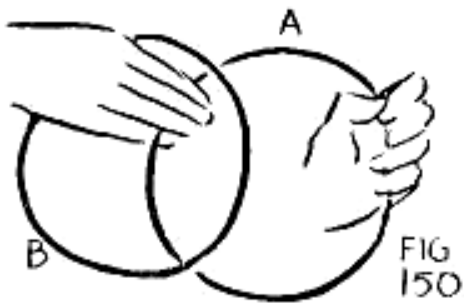
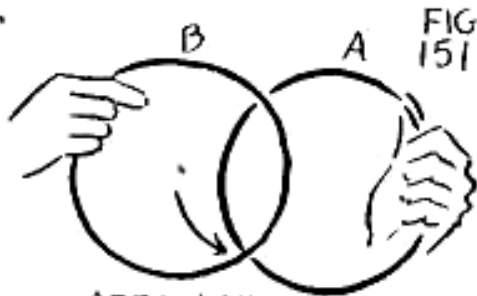


Figure 150.



ARROW SHOWS
POINT WHERE
B CLICKS AGAINST A

Release A from right hand and hold only B in it. Pivot B around a little on A until hands are holding rings by outside edges as shown in Figure 151. Hold rings in vertical position again. B is behind A toward yourself.

In this position, rings seem to be linked together and the following motions convince audience that they are linked.

With rings pressed together, push B toward left hand and then bring it back to position shown in Figure 151. As you do this, raise lower edge of B and then strike it smartly against lower edge of A. Lift lower edge of B about two inches. The illustration shows edge of B lifted higher, but it is just to make it clearer to you how you do this move. Arrow indicates point where B strikes A.

FIG
152

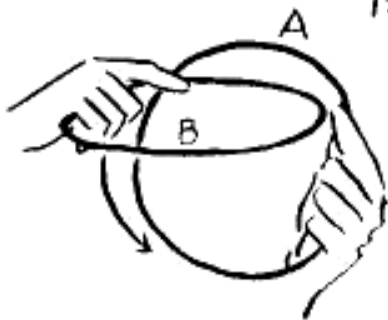


Figure 152.

Repeat this once or twice. Then with circular motion, draw rings apart and hand them out for examination, telling spectators to see whether they can put them together again.

Pick up rings from chair as if they were single rings. Go back to Figure 136 and perform moves from that point through Figure 141. Then pass linked rings out to audience, telling spectators to see whether they can get the rings apart.

Harlan Tarbell

TARBELL SYSTEM, INCORPORATED, Chicago.

* * * * *

The paraphernalia described in this lesson can be obtained from the Tarbell System at the following prices, postage prepaid.

Linking Rings \$10.00

* * * * *

LESSON 48

Oriental Magic again. Here you are taught the famous Hindoo Mango Tree growth which has gained such an international reputation, and a number of other valuable effects.

MORE ORIENTAL MAGIC

We have already discussed certain phases of Oriental Magic. In this lesson, we continue with the work and add to your repertoire with the following experiments:

- 1 - Tarbell's Mysterious Firecrackers
- 2 - Kolar's Balloon and Silks
- 3 - A Chinese Lantern Production
- 4 - The Hindu Mango Tree Growth
- 5 - Tarbell's Hindu Plant Growth
- 6 - Comedy Flower Growth

* * * * *

TARBELL'S MYSTERIOUS FIRECRACKERS

I designed this effect for use when I have children assisting me, although it may be performed with grownups assisting as well. Firecrackers are typical of Chinese effects and this one is something a little different. I know you will enjoy adding this mystic experiment to your repertoire of effects.

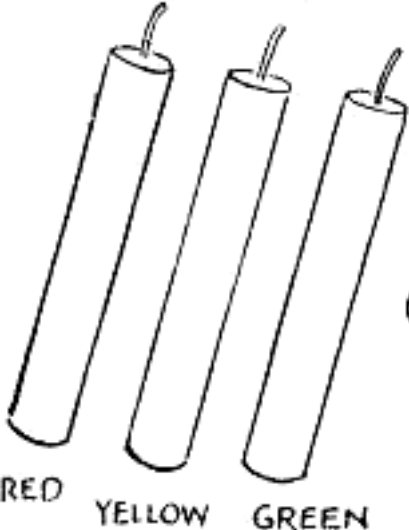
EFFECT:

Three large firecrackers are shown. One is red, one yellow, and one green. A hat is borrowed and two children are asked to come up to assist you. Performer tells children that it is difficult to remember colors, especially more than two at a time. For this reason, he wants them to pay particular attention to see whether they can keep track of three colors. Magician drops each firecracker into the hat, naming the color of each. He then removes the red one, shows it, and wraps it in a piece of paper. He gives this to one of the children to hold. This leaves the yellow and green firecrackers in the hat. Performer asks one of the children to select one of these two colors. Assume that he selects yellow. The wrapped firecracker is then taken out and shown to have turned to yellow and the red one is found back in the hat.

PARAPHERNALIA:

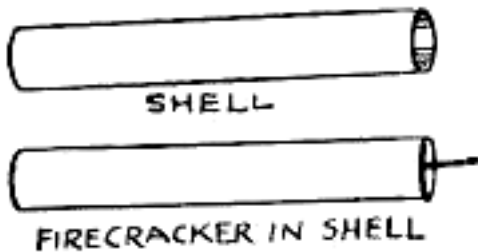
- 1 -- Three imitation firecrackers, red, yellow, and green, respectively.

These are made of wood and are lacquered. A piece of string is used for the fuse. They should be about four inches long and seven-eighths of an inch in diameter.



① Figure 1.

- 2 -- Red celluloid shell to fit over red firecracker. This shell should fit easily so that firecracker can slide in and out. Red firecracker with shell



②

over it must look the same as it does without shell. Also other firecrackers should look like the red one when slipped inside red shell.

Figure 2.

We can furnish you with the set of three colored firecrackers and red shell at reasonable price.

3 -- A sheet of paper about 8-1/2 x 11 inches.

4 -- A Rubber band.

5 -- A borrowed hat -- or your own.

SECRET AND PATTERN:

To Prepare:

Have hat and sheet of paper on table. Arrange the three fire crackers on table with red shell over red firecracker. Have hat also on table. If you borrow hat for experiment, place it on table after you have secured it from spectator.

To Perform:

Pick up the three firecrackers.

"I want a boy and a girl to help me celebrate the Fourth of July."

Go down into audience and give green firecracker to a small boy and the yellow one to a small girl. Get them to hold firecrackers high up, then bring them into the aisle and finally up to the stage. Ask their names and introduce them to each other. Assume their names are Ruth and Ben.

"Ruth, we each have a large firecracker, or as we sometimes call them, cannon crackers. You know what a cannon cracker is, don't you? It is just a little firecracker grown up. These were born in China and if they keep on growing, they will be great big ones. Do you like to shoot firecrackers? Ben, how are you on colors? You look quite patriotic. Are you a color expert? Each of you hold your firecrackers back of you and I shall do the same. Now, Ben, tell me the color of each one of the firecrackers we are holding. What color have you? Green. Fine. What color has Ruth? Yellow. And I? Red. That's well done, Ben. Now each of you give me your firecrackers and I will see whether Ruth can memorize colors also. Suppose we use this vacant hat."

Step back to table. Hold the three firecrackers in your left hand and pick up hat with right. Show hat empty and give it to Ben.

"Here, Ben, hold it up high."

Have Ben hold hat up above his eye level. It must be high enough so that neither the two children nor the audience can see into it.

Figure 3.



③

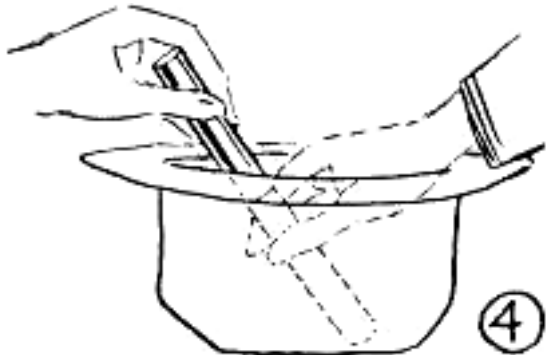
"Ruth, name the colors as I place them slowly into the hat, one at a time."

Hold up red firecracker in right hand.

"Red."

Place in hat, covering top of firecracker with right hand. When it is well down in hat, allow firecracker to slip out of shell on to bottom of hat. Raise end of firecracker again far enough to free shell from it. With right hand still in hat, holding shell, call attention to yellow firecracker in left hand.

"The next is yellow."



Place left hand in hat so that yellow firecracker can be slid into shell easily. When this is accomplished, allow yellow firecracker with red shell over it to lie on bottom of hat beside red firecracker.

Figure 4.

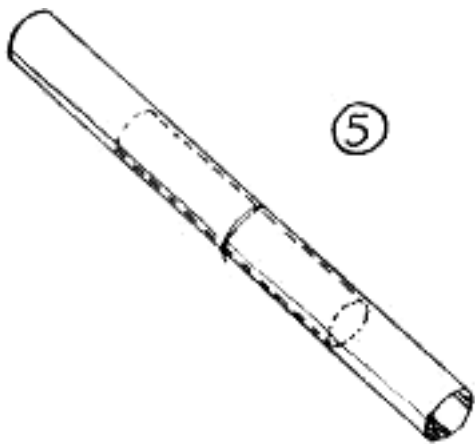
"And the last is green."

Place green firecracker in hat.

"Ruth, can you remember that many colors? Let me remove one of the firecrackers."

Pick up the yellow firecracker with the red shell over it and remove it from hat. To all appearances, it is the red firecracker.

"If I remove the red one, what colors are left in the hat? That's right - yellow and green. Let me wrap this red firecracker in a piece of paper."



Roll sheet of paper around the firecracker and hold it in place with the rubber band.

Figure 5.

Give it to Ruth to hold, warning her to hold it straight horizontally.

"Do you feel the firecracker all right? Well, hold on to it tight and do not let it fall out of the paper to the floor. You say, Ruth, that we have a yellow and green firecracker left in the hat. Choose either color that you want. Use your own free will in making the choice. Which color do you choose?"

Assume that she chooses the yellow one.

"Yellow. Now, Ruth, remember that I gave you your own free choice in the matter. Now I shall give Ben the remaining green firecracker to use as a magic wand. Ben, did you ever startle an audience with prestidigitation? Well, you can

do it now. You can hold the wand and wave it when I tell you to."

Have Ben hold hat with left hand and take green firecracker from you with his right hand.

"As matters stand, I think Ben has the green firecracker, Ruth the red one, and the yellow one is left in the hat. All right, Ben, waive the wand. Ruth, you selected the yellow one, didn't you? The fairies must have heard you for they took the red one away from you and gave you the yellow one instead. It all happened when Ben waved his magic wand."

As you say this, take paper tube from Ruth and grasping shell from outside of paper, tilt tube so that yellow firecracker will slide out into your hand.

Figure 6.

Give yellow firecracker to Ruth and toss paper tube with shell inside carelessly on table. In this way, audience is led to believe that there is nothing inside of paper tube. You may even give Ruth a quick glance inside of paper tube before tossing it aside. When shown quickly, shell will not be visible to her inside of paper tube.

"If we look inside the hat"

Take hat from boy with left hand and turn it so that opening is toward audience. At the same time, remove red firecracker with right hand.

"We find that the red firecracker has traveled over here."

Take firecrackers from children and thank them for assisting you.

When Ruth is given her choice of colors between yellow and green, suppose she chooses green. In this case, remove the green firecracker from the hat and give it to Ben. Then proceed as follows:

"Remember, Ruth, I gave you your own choice color. Seeing as how we are going to use this as a wand for Ben, we have to be quite particular. Ben here is quite a prestidigitator. I think Ruth believes you are Irish because she selected the green wand for you. Now, Ben has the green firecracker. Ruth, what color have you? Red, you say. Wave your wand, Ben."

Take paper tube from Ruth and let yellow cracker slide out of it. Toss paper aside.

"You see, Ben is playing tricks on us, Ruth. You have the yellow cracker and not the red one. However, I believe we will find the red one here in the hat."

Remove the red cracker from the hat and show hat to be empty. Return hat if borrowed and dismiss children to conclude experiment.

* * * * *

KOLAR'S BALLOON AND SILKS

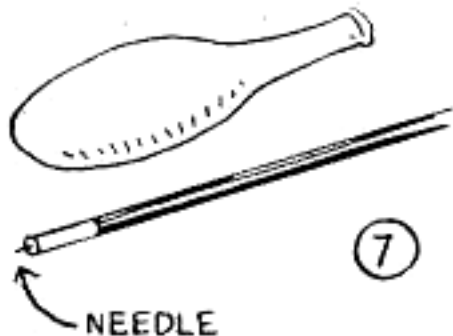
This effect is one of Kolar's favorites. It has a flash finish in the nature of a surprise. Though this is not a trick definitely in the classification of Oriental Magic, it fits nicely into an Oriental program.

EFFECT:

Performer blows up a toy rubber balloon and gives it to lady assistant to hold in her left hand. In her right hand, she holds a wand. Magician then shows a few colored silks and places them in a cloth bag. Suddenly bag is turned wrong side out and silks are shown to have vanished. Magician then touches balloon with wand and it disappears, leaving the silks in its place.

PARAPHERNALIA:

1 -- A toy rubber balloon. This should be large enough to hold a few silks before it is blown up. The kind which sells at ten cents each retail is the best. In quantity lots, you can buy them cheaper.



2 -- Magician's wand with sharp-pointed needle in end. Figure 7 shows balloon and prepared wand.

3 -- From four to six silks of various colors, 13-inch size. Four to six duplicate silks.

4 -- Changing Bag. Use of this was taught to you in Lesson 14.

SECRET:

To Prepare:

Push silks into opening of balloon. If they are packed in carefully, balloon will not look suspicious. Place prepared balloon on table with duplicate silks, Changing Bag, and wand.

To Perform:



Pick up balloon. Blow it up and give to assistant to hold in left hand. Have her hold opening of balloon tight so that air will not escape. Give wand to assistant to hold in right hand.

Figure 8.

Show duplicate silks freely and place them over your left forearm.

Pick up Changing Bag and turn it inside out and back again. Place the silks in it, then turn bag inside out again to show silks have vanished.



Take wand from assistant and with needle-point, prick balloon. The balloon bursts and the silks come flying out. To audience, it appears that balloon vanished and the silks appeared in its place. They are not aware of needle on end of wand which causes balloon to burst.

Figure 9.

* * * * *

Kolar has many variations for performing this experiment. One way is to have a large quantity of silks in balloon and have balloon, already blown up, brought in by assistant. Balloon is then punctured and a shower of silks falls to the floor. Another method is to have balloon suspended up high and have assistant fire shot from air gun from the wings to puncture balloon and release silks.

When Kolar uses an uninflated balloon and blows it up before his audience, he uses this bit of Showmanship. He has three or four balloons on a tray or table. One of these is loaded with silks and another is scratched thin in one spot with a pin or knife. First, he picks up the scratched balloon and blows it up, only to have it burst. Audience thinks it burst accidentally. Then he picks up the prepared balloon and blows it up, proceeding with experiment.

* * * * *

CHING-A-LING CHINESE LANTERN PRODUCTION

There is a clever production principle involved in this experiment which is readily appreciated by the magician. It is my adaptation of the familiar old inexhaustible Jap Box. I have found this new method of working so effective, that it can be used to add a flash number to a vaudeville act as well as to the Chautauqua parlor show or the club stage performance. Stowell uses it nicely in his vaudeville act of "Oriental Oddities".

EFFECT:

A square Chinese lantern that folds down flat is opened and freely shown to be empty. This is placed on a thin, undraped table top. Performer reaches in and pulls out, one at a time, four Chinese lanterns. These he hangs on a pole carried by an assistant. Then he proceeds to pull out a number of various-colored silks, which he drapes over assistant's shoulders. Picking up the silks, he suddenly transforms them into a large brightly colored silk, a butterfly silk, or an American flag.

PARAPHERNALIA:

- 1 -- A specially built Chinese lantern.
- 2 -- Four special Chinese lanterns.
- 3 -- From six to twelve vari-colored silks, 36 inches square.

4 -- A large square silk, rainbow-colored or painted with a big butterfly -- 6 to 9 feet square. A large flag may be used if desired.

5 -- A small, thin-topped table, or ordinary card table.

6 -- A pole or bamboo stick, about four feet long, on which to hang lanterns. Part of a bamboo fishing pole is suitable.

SECRET:

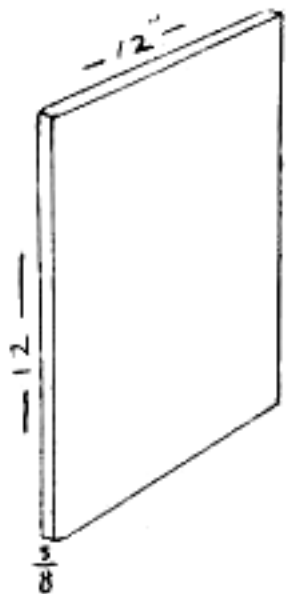
To Construct:

Square Chinese Lantern -



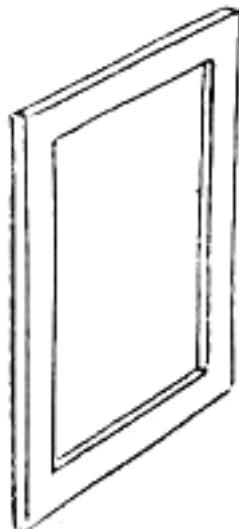
This consists of four walls and a top. It resembles the lantern used for production in Lesson 38, but this is more elaborately constructed. The load in this case is carried in the walls themselves.

Figure 10.



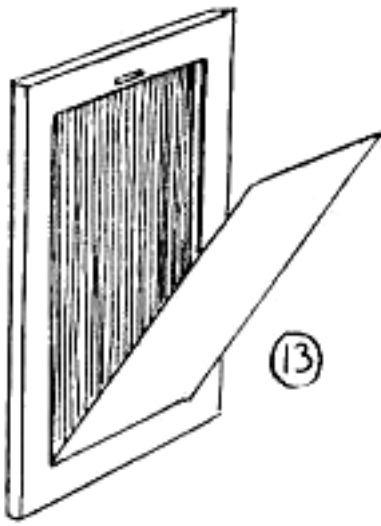
Each of the four sides is twelve inches square and five-eighths of an inch thick.

Figure 11.



To construct these sides, one-inch wooden frames are used as the foundations.

Figure 12.



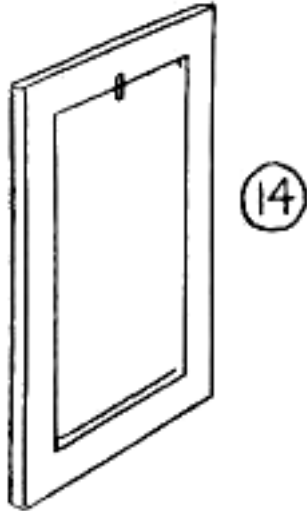
A sheet of tin or zinc is then tacked to one surface of each of these sides. To the other surface a similar sheet of tin or zinc is tacked, but this sheet has a door cut in it, slightly larger than the inside measurement of the wooden frame. This size enables the door to rest against the wooden frame when closed. Door is hinged at the bottom and held in place by a small catch at the top.

Figures 13 and 14.

Paint the insides of the four walls black and the outsides in brilliant Chinese colors. From a short distance, each wall looks like a square painted board without any trick arrangements.

Hinge the four walls together, black surfaces on the inside. Hinges are placed inside.

(48-7)



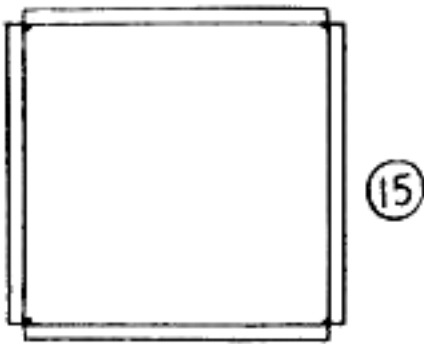
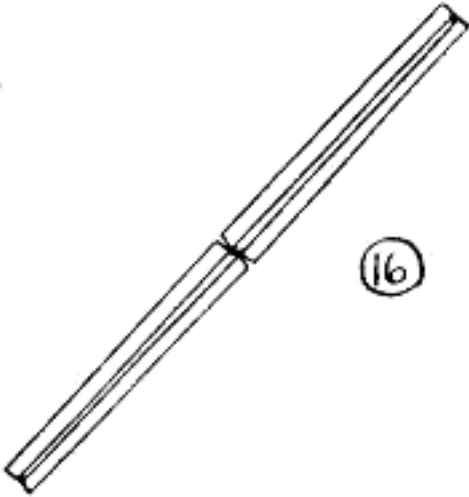
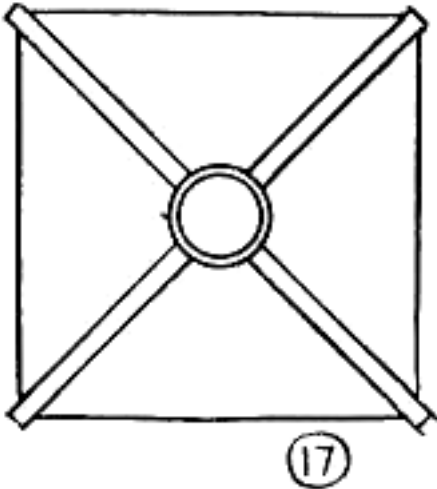


Figure 15.



Arranged in this way, the sides can easily be folded down flat.

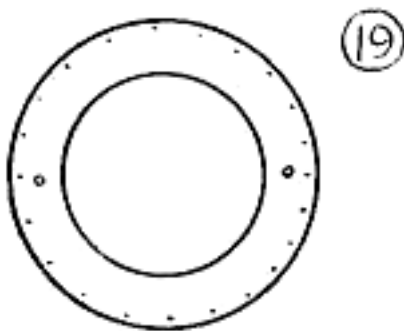
Figure 16.



Construct the top of thin wood as shown in Figures 17 and 18. Refer back to Lesson 28 for detailed instructions. Top should fit over lantern as in Figure 10.

Smaller Lanterns -

These are for production purposes and are to be concealed in the hollow sides of the walls of square lantern. These lanterns must therefore be so constructed as to fold up flat.

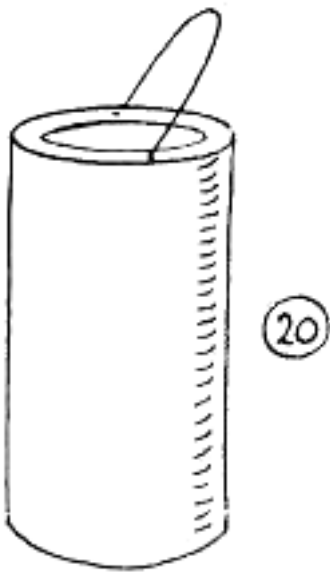


To build this lantern, take four round pieces of cardboard, about five or six inches in diameter. Cut out the insides, leaving about an inch edge. Punch holes around the outside edges of two circles. Also punch two larger holes, one on each side of one circle, for the handle to come through.

Figure 19.

To one circle with holes punched in it, sew the edge of some fine, colored silk. Sew opposite edge of silk to other circle with holes. To finish off lantern, paste plain circle of cardboard to top and bottom. For a handle, run some cord through cardboard at top and knot it on the inside of lantern.

Figure 20.



20



21

These lanterns may be made of flowered silks or plain colors with designs painted on them. Four to six of them may be used in this production, and they should be made in a variety of colors. To the bottom of each lantern sew a piece of cardboard in different shapes to give a tassel effect.

Figure 21.

The Silks -

The 36-inch silks should be washed well to take out the stiffness. A good grade of Chinese silk should be used for them and they should be in a variety of colors. If possible, paint some Chinese designs on them. On the upper corners of each silk, sew a white button and a black button so that you will be able to pull them out properly in the effect.

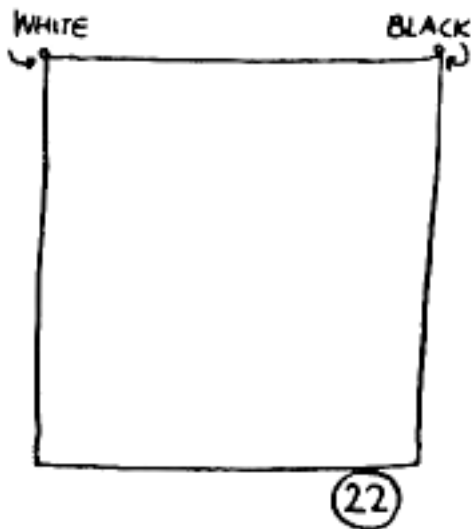


Figure 22.

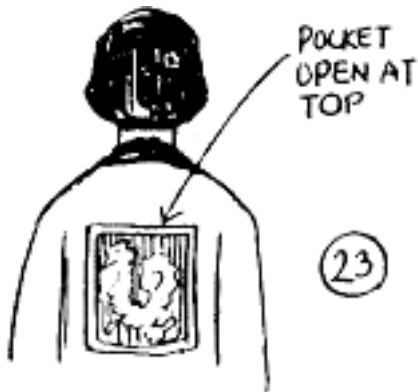
The Butterfly Silk -

This is a beautiful flash for a finish and can be made from six to nine feet square. Get 36-inch width Chinese silk and sew pieces together to get required size. Hang on wall when finished and paint a large, brightly-colored butterfly on it.

To Prepare:

When all your apparatus is made, the following preparation is necessary.

Open the door of one side of lantern and pack it with as many of the folded small silk lanterns as possible. Then close door and secure it with catch. In the other sides pack balance of lanterns and the folded silks and lock the doors with catches. A roll of half-inch ribbon may be placed in one side for production.



The Butterfly silk is usually not placed in box but is concealed on assistant. If a man assistant is used, the folded silk may be suspended from a clip under his coat or may be pinned or clipped to his back. If a girl assistant is used, she may have it attached to her back or placed in a specially decorated pocket in back of Chinese coat. Large silk can also be concealed in rear of back of chair.

Figure 23.

To perform:

Lantern is standing on table with lid on it. Remove lid, show it freely, and set it to one side. Or place lid on assistant's head for a hat.



Figure 24.

Pick up lantern and hold it up so that audience can see through it. Drop it flat down on table as shown in Figure 16 to convince audience that it is empty. Pick up lantern again, open it, and show again. Place on table, opened out in upright position.



Reach into lantern and open door of side containing small lanterns. Undo catch and hold door until it is down on table so that it will not make a noise. Remove a lantern by the handle and let it open out as you pull it from box.

Figure 25.

Place lantern on a bamboo pole or stick held by assistant, or hang on nearby hook for stage decoration. Continue producing the lanterns and hanging them up until all are out of the box.

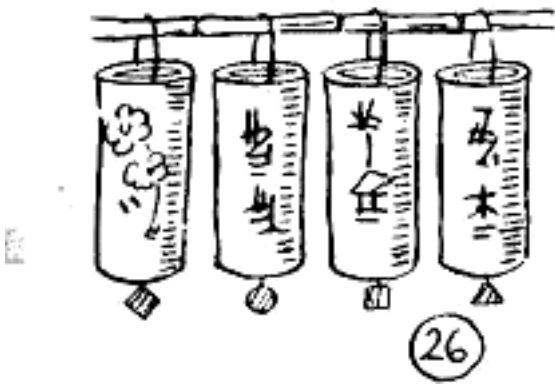


Figure 26.

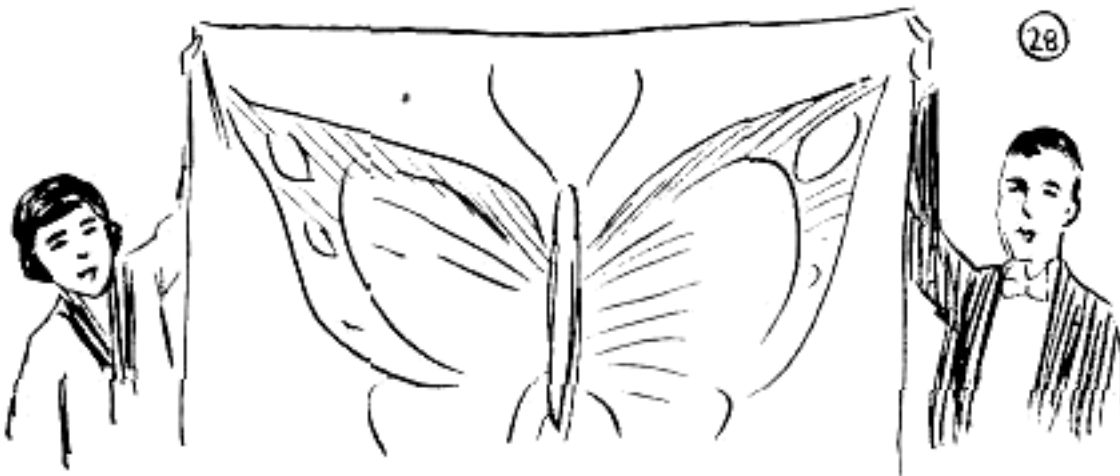
If placed on pole carried by assistant, she can easily carry pole offstage and then come back. A cord or wire may be stretched across stage on which to hang lanterns. If you are going to do this, attach a clip or hook to handle of each lantern, or attach enough hooks to wire to hold lanterns.

Fasten door of side from which production was just made inside of box and show box empty.



Now open door containing silk load and remove silks one at a time, displaying them and placing them alternately over each of assistant's shoulders.

Figure 27.



After last silk has been displayed and laid on assistant's shoulders, gather up these silks and under cover of them, pick up the big butterfly silk or flag. Assistant grasps one of the buttons on it and you grasp the other. Pull away from assistant with a flourish so that butterfly silk or flag opens out quickly. Allow the other silks to drop to the floor as you display the big silk. This makes a nice finish for the effect.

Figure 28.

* * * * *

THE HINDU MANGO TREE GROWTH

Great tales have come out of the Orient about the remarkable mango tree growth performed by the magicians. Descriptions of the

effect vary according to the imaginations of the people who tell about it. Many who have never seen the effect but have merely read or heard about it discuss it as if they knew all about it. Everyone seems to consider this experiment in which the magician puts a seed into the ground and suddenly causes a tree to spring up as a mystery of mysteries.

Because of this peculiar respect which the public has for the mysteries of the Hindus and because of the public's overwrought imagination regarding the mango tree mystery, the modern magician would do well to capitalize on this effect.

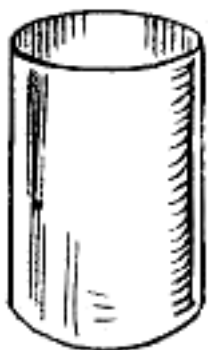
Here is your opportunity to work up a feature number which will give you excellent publicity. Accent the fact that this Hindu Mango Tree Mystery is one of the most difficult in all the world to fathom and that you came across the secret in a peculiar manner. Impress it on the public that it is a rare privilege for them to be able to see this profound bit of magic of the Far East performed before their very eyes. If you study this effect and present it with good Showmanship, it will seem a veritable miracle to your audiences.

Hindu Magic is, of necessity, different from ours here in the Occident, because of the difference in conditions under which it is practiced. The Hindu sits on the ground out in the open with the sky as the roof of his theater. He must employ methods of performing his magic which are adapted to his environment. We, on the other hand, perform our magic in rooms, clubs, theaters, and we can utilize methods for gaining an effect which is impossible for the Hindu to use.

First, I shall describe the Hindu Mango Tree Growth as it is performed by the Hindu Magician on the streets of India. Then I shall discuss the presentation in our own modern environment.

EFFECT:

Performer plants a seed in a can of earth or sand. He shows a cloth and then covers the jar of earth with it. After a moment, the cloth is removed and a small sprout with leaves is found growing in the earth. The can is covered again and behold! -- when the cloth is removed, a mango tree about eighteen inches tall with pieces of fruit on it has grown up in the can.



(29)

PARAPHERNALIA:

1 -- A tin can or jar full of earth. Sand may be used, if desired.

Figure 29.

2 -- A cloth about five feet square -- must be opaque.

3 -- A plant covering.

4 -- A plant or small leafy piece cut from a tree. This should be about a foot and a half high. To this fasten a few small lemons, limes, kumquats, or plums.

Figure 30.

5 -- A small leafy sprout.

6 -- A large seed.

7 -- A few pieces of cloth or articles of clothing to be piled up to right and left of performer.

SECRET AND PATTERN:

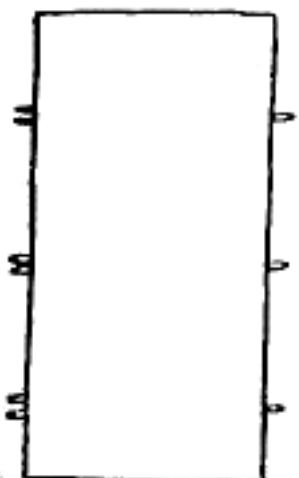
To Prepare:

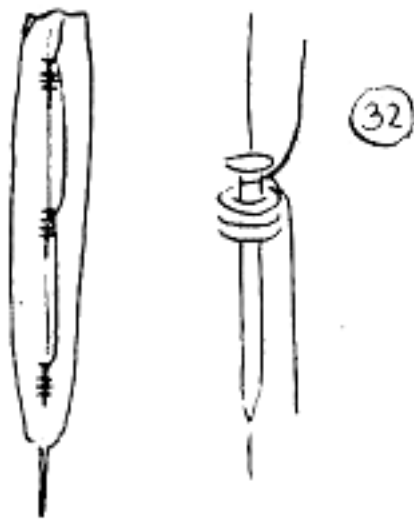
To facilitate the handling of the plant it is necessary to wrap it in a cloth bag arrangement which will hold it in as small a space as possible. At the same time, this cloth must be fixed so that it will slip from plant easily. A satisfactory bag is made by using a piece of black cloth or cloth the same color as the covering cloth to be used later. This should be cut long and fairly narrow and small rings sewed to the long edges.

Figure 31.



(31)

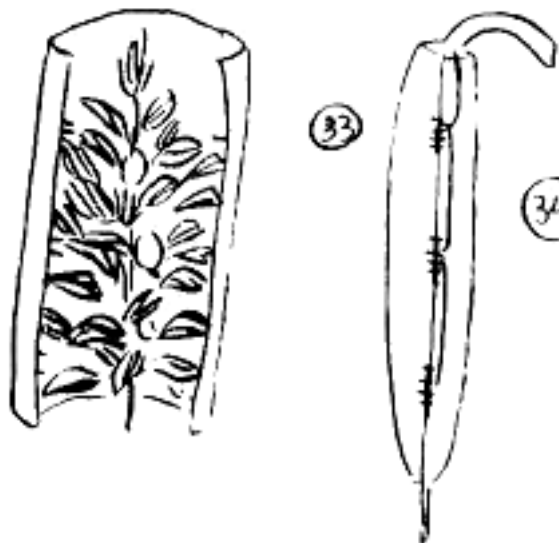




Wrap this cloth tightly around the plant and hold in place with nails put through the rings. Attach a string to the tops of the nails as shown in Figure 32.

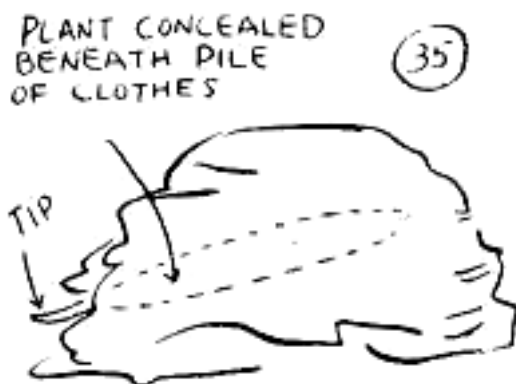
When string is pulled from the top, all the nails are pulled out of rings and covering of plant is released. Nails are kept together by string.

Figure 33.



At top of covering for plant, sew a three-inch strip of cloth.

Figure 34.



Place pile of clothing to your left. This pile may be performer's coat with one or two turban cloths. Place plant under clothes so that it is completely concealed except for the three-inch strip at top of plant covering. This should be toward you so that it can be easily grasped. This strip is used merely for facility in working. It can be arranged so as not to attract any attention. On top of pile place the five-foot cloth used later to cover can of earth.

Figure 35.

The impression conveyed to audience is that this pile contains articles to be used during the performance.

In performer's right pocket are the large seed and the small leafy sprout. Or sprout may be in sash which he wears round waist.

To Perform:



The Hindu sits on the ground, his jar of earth in front of him. The pile of clothes with plant concealed under it is at his left side. Other cloths and apparatus, including a musical instrument known as a flageolet, are at the right.

Figure 36.

He picks up the jar of earth and shows it freely. He may even turn the earth out of the jar and fill it up again. Or he may have the can empty and fill it from a box of earth or sand nearby.

He pats the earth down in the can. Then takes a seed from his pocket, shows it, and then plants it into the earth in the can. If he has a can of water nearby, he waters it a little.



He then picks up the five-foot cloth from the pile on his left and shows it on both sides. Next he covers the can of earth by holding this cloth over it, tent-fashion, in his left hand.

Figure 37.

After a few moments, he lifts off cloth and throws it back on his lap. While directing attention of audience to jar of earth, he palms out the small sprout from his pocket under cover of cloth on his lap.

(48-12)

"Nothing happen. Maybe seed no good. Water him more."

He picks up can of water and wets earth a bit more.

"We try him again."



38

He covers jar again, holding center of cloth in left hand as before. Under cover of cloth, he reaches under with right hand and plants leafy sprout into earth in can.

Figure 38.



39

Perhaps at this time he drops cloth over can and sprout, and picking up his flageolet, plays an oriental tune.

Figure 39.



40

He picks up center of cloth over can again and tosses it onto pile of clothes at left so that center comes over strip of cloth on plant cover. He spreads cloth out and then calls attention to the leafy growth in the can.

Figure 40.



41

"See, plant grow better now."

With left hand he quickly pulls up covering cloth again, grasping it at the center and pulling up under it the strip of cloth attached to plant cover.

Figure 41.



As cloth is pulled up in this manner, plant is drawn up also and concealed inside of it. This movement is made in a careless manner, handling cloth as before.

Figure 42.



Covering is again held tent-fashion over jar and performer spreads lower edges of cloth down on ground around jar. He then reaches up under cover with right hand and pushes center stalk of plant down into the earth in can.

Figure 43.

He quickly pulls the string up from plant cover, freeing the nails and releasing the cover from plant. Plant cover is still held by left hand through large cover over jar, as in Figure 43.

"Him grow maybe three inches, maybe four inches."

Performer spreads the plant out a little under cover of cloth and suddenly removes cloth, carrying with it the small plant cover, and tosses it aside.

44



Audience can now see full-grown plant. Hindu may pick off one of the pieces of fruit and give it to a spectator to taste.

Figure 44.

This is one of the favorite methods for performing the Mango Tree Growth used in India. It is simple to work, yet it is very puzzling. Showmanship must be put into the performance, however. Care must be taken in handling the cloth in a free and easy manner to give impression of merely tossing it aside to show jar and then holding it up just to cover jar. Eyes and attention of performer must be kept on the jar for MISDIRECTION.

Pile of clothing may be to right or left, as desired. The small leafy sprout may also be concealed in the pile instead of in the pocket.

This effect is designed for work out in the open and on the ground, yet it can be produced Hindu fashion on the stage by using similar properties to those which the Hindu uses in performing the experiment. The effect will have to be worked up to a little quicker tempo, however. The Hindu takes his time about growing the plant. He is not working in vaudeville, and fifteen minutes more or less doesn't mean much to the magician in India. The effect may be produced on the floor or on a large table on a stage with excellent results in a modern program if presented with snap and good magical Showmanship.

* * * * *

TARBELL'S HINDU PLANT GROWTH

This is my own method of working the Hindu Plant Growth. This is the ideal way of working the effect and enables you to perform the mystery almost any place where the audience is kept well in front of you. If you do Oriental work, you should add this feature to your program. This method requires a specially built Oriental plant, but it has the advantage of being made so that it can be used over and over again. It can be adjusted in a few moments and enables you to work in a truly magical way.

In my Oriental program I have had to produce almost miracle effects to live up to the stories about the Orient, and I consider this Hindu Plant Growth and my Hindu Rope Mystery as two of the most important effects in this type of magic. Up to the time of writing this course, I kept the methods for these two effects away from the magic profession as a whole. I used them only for my own special performances. I originally intended never to disclose these special Oriental effects but to keep them for my own exclusive use. However, my desire to make this the great Magic Course of all time and my desire to equip my students with the unusual in magic to insure their success - these things have prompted

me to reconsider, and I have decided to give you these two valuable effects. My Hindu Plant Growth is taught to you here. My Hindu Rope Mystery will be taught to you in Lesson 50. With these two you can create a sensation in Magic.

EFFECT:

Performer shows a jar or can of sand and plants a seed therein. He next shows a cloth on both sides and holds it up in front of the can for a moment. Cloth is dropped to reveal can, but nothing has happened. He holds the cloth up in front of can again, and once more removes it, this time to show a small plant growing in the sand. For a few moments can is again concealed by cloth and when revealed again is seen to contain a large plant about a foot and a half tall. Plant is this time covered by cloth and when exposed to view again has fruit growing on it. Fruit is removed and passed out to audience to taste.

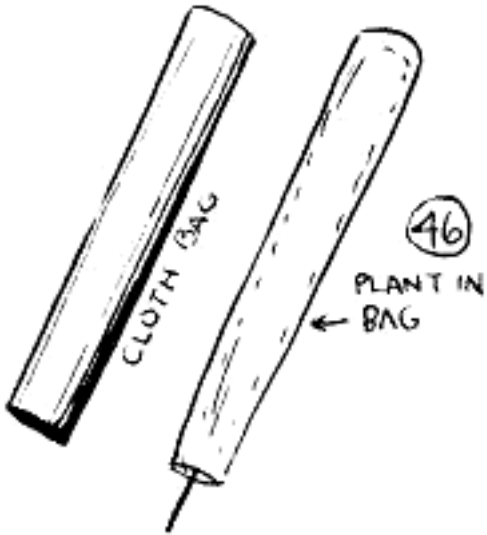


45

PARAPHERNALIA:

1 -- A special Oriental-looking plant made of metal ribs covered with green feathers.

Figure 45.



46

This plant is so built that when open it looks large yet when closed up it can be concealed in a small space. It can be placed inside of a small black bag as shown in Figure 46.



47

2 -- A small plant growth, three or four inches tall.

Figure 47.

3 -- A tin can or jar and a box of sand.

4 -- Two or three small lemons, limes, kumquats, or plums to hook on to plant.

5 -- A large oriental cloth made of dark, opaque material, about 36 inches square.

6 -- A fairly large seed, such as a pumpkin seed or the kernel of an almond nut.

7 -- A table with thin top, such as a card table.

8 -- Black bag to cover plant.

NOTE:

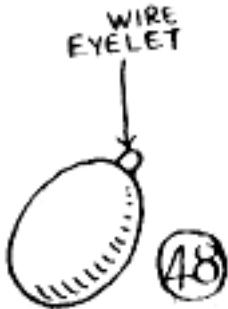
We can supply you with the paraphernalia for this effect, complete and ready for your use. It includes

the large plant, the small plant, the oriental cloth,
and can. Price is reasonable.

(48-15)

To Prepare:

The plant is so arranged that the main central stalk is rigid enough to keep the plant upright and to hold the fruit which is attached to it with hooks. The bottom of the plant is so made that it can be easily inserted in the sand. Plant should be steamed occasionally to keep the feathers fresh. To do this just hold plant over the steam from a pan or kettle of water. Before each performance, shake plant a little to fluff it out.



Just before performing, insert wire hooks into the ends of your pieces of fruit so that they can be attached to stalk of plant.

Figure 48.



Insert plant in bag, putting in bottom end of central stalk first. Then pin top end of bag up at shoulder of coat under left side.

Figure 49.



See that bag hangs properly and causes no bulge in coat. You can move about and perform without its causing you any discomfort. You can even walk into a club room or home and perform the Hindu Plant Mystery when you know this secret. It causes amazement because of the size of the plant which is produced, apparently from nowhere.

Figure 50.

Place the small plant in your right coat pocket, also the two or three pieces of fruit which have been prepared.

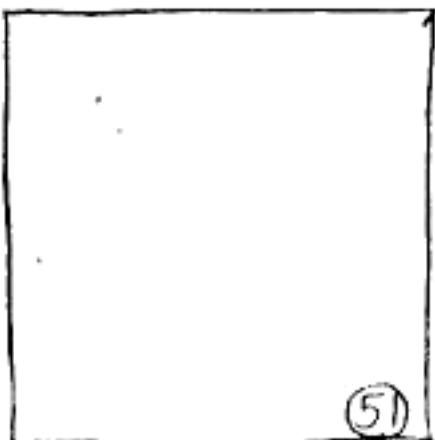
In one corner of the oriental cloth, place a bent pin. First push the pin through up to the head and then bend pin over to form a hook.

Figure 51.

To Perform:

Have tin can on table -- also a box containing enough sand almost to fill can. Have oriental cloth folded up and lying on table.

"Perhaps one of the most amazing magical effects in the eyes of the public is the one performed by the Hindu magician in which he plants a seed in the ground and causes a Mango tree or plant to spring up and bear fruit. There have been many stories told about this remarkable magical feat. Many have tried to solve it without success. When you consider the way the Hindu does it in India - right out in the open, on the



ground, it is still more mysterious. For years I have been interested in this peculiar Hindu effect and finally discovered the secret. Tonight I want to tell you of this odd effect. While it is not convenient for me just now to sit

(48-16)

on the ground out of doors in India, yet I can explain matters to you with a few articles on the table here. For the experiment, I use this tin can."

Show tin can empty.

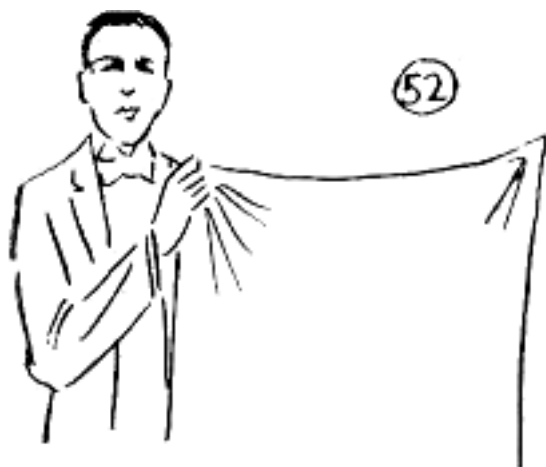
"A small box of sand from which I pour enough sand almost to fill the tin can."

Pour sand from box into can.

"A cloth, this table, and a seed. By the way, this seed is an oriental one. I shall plant it in the sand."

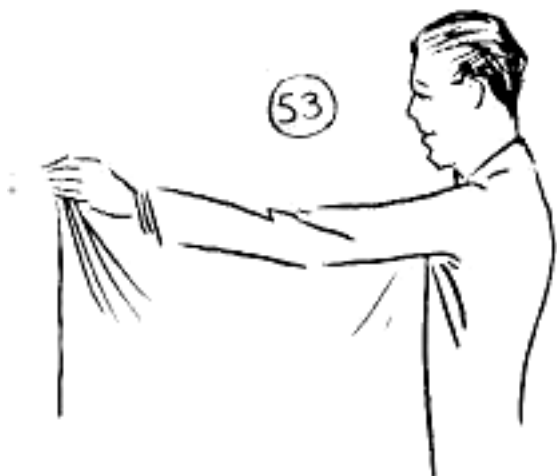
Plant seed in the sand after showing it to audience. If you desire, you may only pretend to plant a seed; however, a large pumpkin seed or almond nut kernel adds showmanship.

"Normally, it requires some time for this seed to sprout and grow up, but the Hindu has discovered some odd methods for directing nature's laws. He says that warmth is very important, but not too much warmth. He usually covers the seed with a cloth, perhaps for the same reason that we cover growing or sprouting vegetables at times with straw or paper."



Pick up oriental cloth and grasp corner with bent pin in right hand. Spread out cloth to show it, stretching left arm out straight and bringing right hand with pin to left shoulder.

Figure 52.



Swing around to the right. This brings cloth in position to conceal can of sand on table. Figure 53 is view as audience sees you at this point.



Hold cloth this way about five seconds, then bring left and right hands together and hold both corners of cloth in left hand. Look at can, and pick it up to show nothing happened while it was covered.

Figure 54.

"I guess I really didn't give the seed time enough to sprout."

Replace can of sand on table and hold up cloth again as in Figure 52. Then swing around and screen can again as in Figure 53.

This time be careful that cloth comes down close to your left side so that nothing behind it can be seen. Hook pin to left shoulder with right hand,

thus releasing right hand for action. Audience is not aware of pin in cloth and consequently thinks that you continue to hold cloth with right hand.

Reach into pocket and bring out small plant. Place it in can of sand as if it were growing there. Bring right hand back to left shoulder again. Bring head forward and look at front of cloth for a moment. Also raise right hand with cloth

(48-17)

a bit to show hands really hold cloth. This is for misdirection to convey idea that you have nothing to do with what is going on behind cloth.

Finally, swing body to left and bring right and left corners of cloth together again as in Figure 54. Call attention to small growth in can. Pick up can and turn it around so that audience can see plant growing. Replace can on table.

"Some action has started -- at least a few leaves have appeared."



Go through routine of concealing can again. Hook pin on left shoulder. Under cover of cloth, remove small plant from can with right hand and replace it in pocket. Then reach under left side of coat, grasp bottom of central stalk of big plant, and pull it out.

Figure 55.



Push stalk into sand in can and spread plant out a bit to make it look as though it were growing there.

Figure 56.

This movement of getting plant is simple. Do not move coat any more than necessary. You can look at audience and talk to them while doing it.

"When a Hindu magician performs this, he can take as much time as he wants. Fifteen minutes or half an hour in India doesn't mean anything. Besides, he can play a flageolet, which by the way is his idea of music. It is said that music charms the flowers and hastens their growth. That is why I play a mandolin while doing this."



Bring right hand up to left shoulder and unhook cloth. Raise cloth with right hand a little to show audience that you hold cloth with right hand. Swing around and drop cloth by bringing two hands together again, thus exposing plant in can.

Figure 57.

"There, we have a well grown plant."



58

Conceal plant with cloth again, as before. Reach into pocket with right hand, remove the pieces of fruit, and hook them to the central stalk. Swing around again to reveal plant with fruit growing on it.

Figure 58.

"Or, better yet, here we have the plant bearing fruit. You might be interested in tasting this remarkably grown fruit, so I shall let a few of you taste it."

Remove fruit, quickly pulling out the wire hooks so that audience will not see them. Cut fruit into halves and pass out to a few spectators.

"You will notice its true oriental flavor."

(48-18)

If desired, salt may be put into the fruit before performing the experiment to give it a salty taste. This is not necessary, however.

* * * * *

COMEDY FLOWER GROWTH

This effect has been designed for comedy work and can be fitted in to many programs to add a light, humorous touch.

EFFECT:

A small plant is seen growing in a jar. Performer waters it with a sprinkling can and the plant suddenly grows up about a foot. At various times during performance, magician waters plant until it grows many feet tall.

PARAPHERNALIA:

1 --A bunch of artificial flowers with leaves. This bunch should be about twelve inches across. To the bottom of bunch attach a piece of very soft clothesline or bathrobe cord, dyed green. Clothesline should be from twelve to eighteen feet or longer, if desired. About every foot or two on the rope sew an artificial leaf or two. Make these leaves of tissue paper or stiff green cloth.

2 -- A plant jar.

3 -- A sprinkling pot.

SECRET:

To Prepare:



To top of plant, tie a black thread. Run this thread up into the scenery or flies above the stage, bring it through a staple, then down to side of stage where it is fastened to a nail driven into scenery. This must be so arranged that assistant back of scenes can pull thread, thus raising the plant. To begin with, flowers must fit into top of jar. Coil the rope attached to plant into jar. Thread now extends upward from plant in jar.

Figure 59.

To Perform:

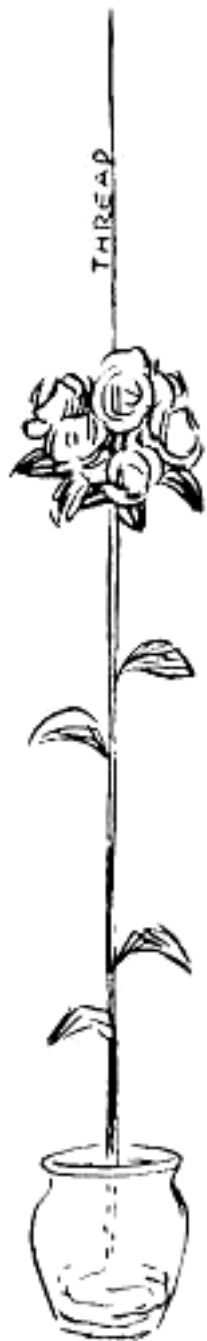
After having performed a trick, go over to the jar of flowers which you have at one side of stage.

Pick up sprinkling can and pretend to water flowers. As you do this, have assistant in the wings pull thread and cause plant to grow up about a foot.

Figure 60.

Perform another trick and then repeat this watering of





the plant and having it grow. Each time assistant causes it to grow two or three feet. You can continue this after performing a number of tricks and the effect is very funny. Another comedy touch may be added by causing the plant to dance when it is about five feet high. This is accomplished by raising and lowering thread.

Figure 61.

If desired, this comedy growth may be performed as a complete effect in itself without intermingling with other effects. This may be performed by your assistant after you have performed a real magical flower growth.

(61) A good finish for this effect is this. Have plant spring up a couple of feet every time you sprinkle it. At the end, make it shoot up into the flies above and then cause it to sink back down into pot again by sprinkling a powder on it, which you tell audience is a diminishing powder.

Harlan Tarbell

TARBELL SYSTEM, INCORPORATED, Chicago.

* * * * *

The paraphernalia described in this lesson can be obtained from the Tarbell System at the following prices, postage prepaid.

Tarbell Cannon Crackers\$ 3.50

Mango Tree Growth 20.00

* * * * *

LESSON 49

This will be another lesson on Oriental effects, giving you more interesting and valuable experiments in this field of Magic. Included in this lesson is the famous production of bowls of water as performed by the Chinese.

SPECIALTY CHINESE MAGIC

One of the best informed men on Oriental Magic in the world today is Percy Abbott, the eminent magician. Mr. Abbott has lived among the Oriental mystifiers and has in that way gained a great deal of secret, inside information on their magic. I feel indebted to Mr. Abbott for the help he has given me in presenting the correct methods of working certain oriental effects and in simplifying other problems in this field of magic.

This lesson is of tremendous significance in its presentation of unique Chinese Magic. Its value can only be measured in the success it brings the performer who aspires to do Chinese effects.

Some of these effects were feature numbers with the great Ching Ling Foo, who was one of the most famous of Chinese magicians. His marvellous production of large bowls of water out in the center of the stage and his production of a large bowl of water while turning a somersault are unforgettable. Foo had a keen sense of showmanship -- of misdirection -- and of speeding up an effect at the psychological moment. He used all the art of the stage, injecting all the graceful and dramatic elements that made him a master. A simple trick in his hands would hold an audience spellbound.

One of the reasons for the success of his effects, too, is that he guarded his secrets almost as he would his life. He knew that he must keep his methods of working wholly to himself. Of course, you can readily understand why Foo had this attitude toward his effects. He spent a great deal of money and long hours and worked very hard to get his magical knowledge and to perfect himself in his profession. Is it any wonder then that he appreciated it deeply and put such high value on it that he guarded it as a treasure?

The fear has sometimes entered my mind that because you are having all this great magical knowledge handed to you "on a silver platter," as it were, you will not fully realize its rich value and appreciate it for its worth. Don't, I beg of you, treat your Magic lightly. Guard your knowledge and effects as profound secrets that you are especially privileged to have. And if you ever doubt the value of the simplest trick, just stop to realize what Magic has meant to the world since time immemorial and what it means to you today commercially.

Ching Ling Foo and other great magicians kept their secrets sacred and now that you are privileged to have these very secrets, guard them as you would priceless gems and use them in a masterly way.

* * * * *

Most Chinese Magic is performed in pantomime (without patter), except for occasional ejaculations. I shall leave it to your judgment to use expressions which sound Chinese when you think it will help the action.

PRODUCTION OF A LARGE BOWL OF WATER

This experiment is a favorite with Chinese magicians.

EFFECT:

Performer shows a large cloth on both sides and runs it through his hands to show that it contains nothing. He throws it on the floor, as though expecting something to happen. Again he raises the cloth and shows it freely. Once more he spreads it on the floor and a large object is seen to have appeared under it. When cloth is removed, this object is found to be a large bowl of water. Magician pours the water out from the bowl into two other vessels.

PARAPHERNALIA:

- 1 -- Large bowl, about 15 inches in diameter.
- 2 -- Special cover for the bowl.
- 3 -- Special harness to wear on body to support bowl of water.
- 4 -- A Chinese costume.
- 5 -- Large decorated cloth -- heavy and opaque.

SECRET:

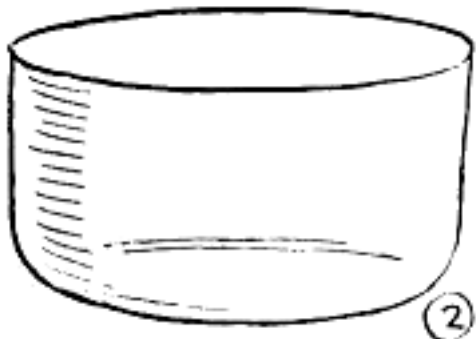
To Prepare:

The Bowl -



This bowl may be of metal, glass, or china. The glass bowl is usually preferred because goldfish may be placed in the water and seen through the glass by audience. However, because of the care necessary in carrying a glass bowl, a good substitute is the ordinary enameled dishpan which may be brightly lacquered and decorated with Chinese figures.

Figure 1.



Glass and china bowls come in various shapes, the most common being those shown in Figures 2 and 3. Ching Ling Foo used the glass bowls and also the large decorated China bowls similar in shape to that in Figure 3.

From an economic standpoint, the prepared dishpan is the least expensive and the best to practice with and use until you have mastered the effect.

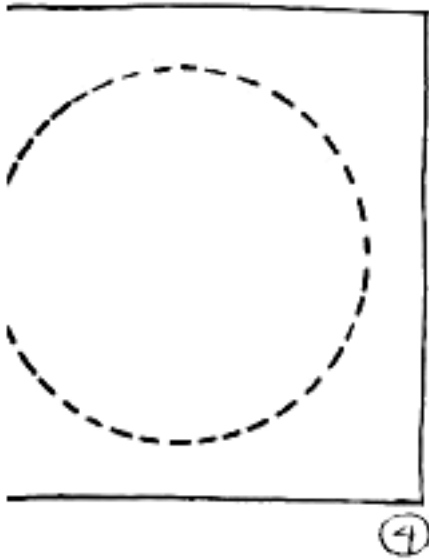
The Cover -



Essential in this experiment is to have the bowl of water so covered that the water will not leak out no matter in what position the bowl is placed. There have been many theories and suggestions for properly covering a large bowl. A special

rubber cover will serve the purpose for a comparatively small bowl, but for a large one something more substantial is needed.

Foo guarded his covers very carefully. It has been said that he used a special animal skin, perhaps sheepskin drawn tight like a drum. But regardless of this, the Chinese magician finds a cover combining a piece of canvas with rubber sheeting satisfactory.



To make cover, get a square piece of canvas somewhat larger than the bowl. Figure 4 shows relative proportion between cloth and bowl.



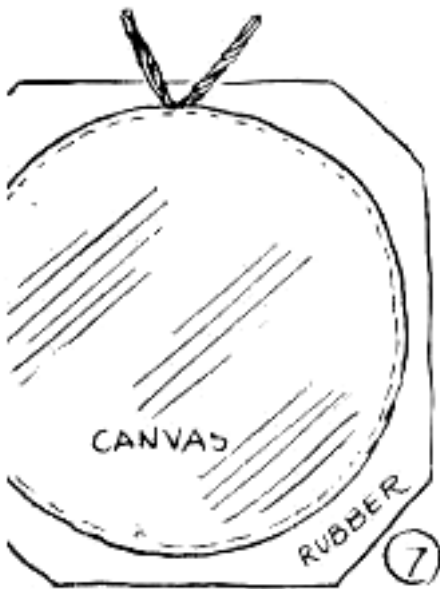
Place the canvas over the bowl and tie a piece of half-inch rope around upper edge of bowl. Stretch the canvas fairly tight and draw the rope as tight around the bowl as possible. The rope must be very tight to prevent leakage when water is in the bowl. Tie the rope, allowing about five inches of ends below the knot. Knot may then be sewed with strong linen thread and rope drawn even tighter by means of thread on each side of knot.

Figure 5.



Bring up lower edge of canvas over the rope. Cover rope and sew canvas tight over it, trimming off excess cloth. This sewing holds rope in place.

Figure 6.



Secure a piece of rubber sheeting from a drug store or hospital supply firm and cut out a piece a little larger than the canvas cover. Sew the rubber sheet securely to the ends of the rope at the place where they meet. This keeps the canvas and rubber fastened together and prevents accidental dropping of one or the other.

Figure 7.

Fill bowl or pan with water to within about an inch of the top. You may cut out pieces of carrot shaped like goldfish and drop them into the water. At a distance, these actually look like goldfish.



Place cover on bowl, rubber side down. Push the rope down carefully around top of bowl, thus holding the canvas and rubber sheet in place.

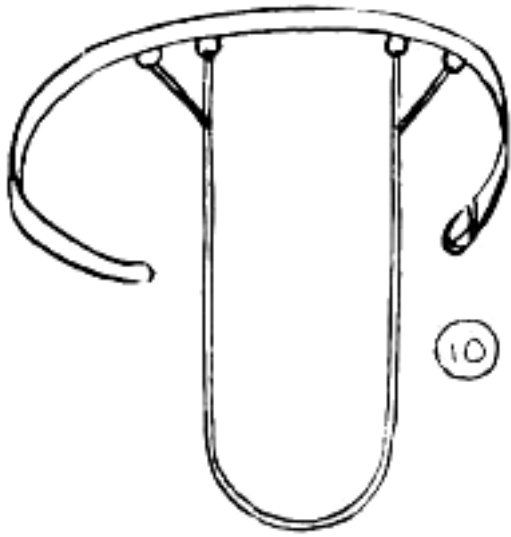
Figure 8.



Another cover which Percy Abbott uses is similar to this one described above but he does not sew the rope into the canvas cover. He merely attaches the canvas to the ends of the rope, in the same way that the rubber sheet is attached. Thus in covering his bowl, he places the rubber sheet down first, then the canvas, and brings the rope down over both about an inch or two below top of bowl.

Figure 9.

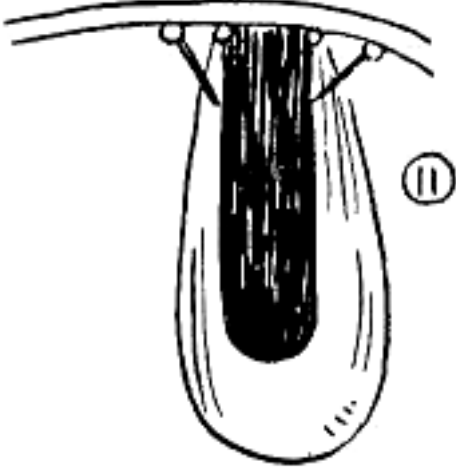
(49-3)



The Harness -

Figure 10 shows general construction of harness. A belt is used to fit around performer's waist. A good harness has four metal rings fastened to the belt. Attached to these rings is a long piece of clothesline with two shorter pieces to reinforce it as shown in diagram.

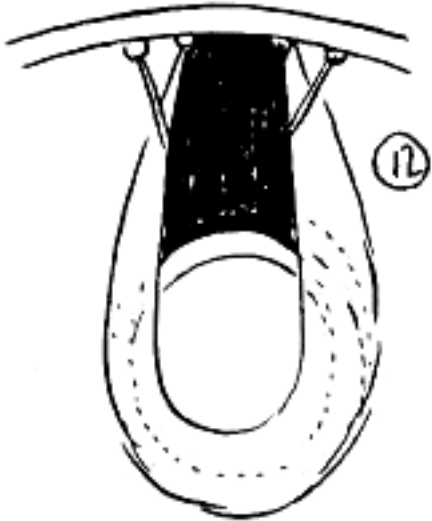
10



A bag of black cloth is sewed to the rope, the two inner rings, and the belt. The bag has an elongated opening in it around which the rope acts as stiffening. The darkened part of diagram shows opening of bag which is sewed to rope.

11

Figure 11.



The bowl is placed in bag with bottom of it toward opening of bag. Bowl is thus standing up on one side.

12

Figure 12.

Belt is then fastened around performer's waist with the bag and bowl of water hanging down behind. When harness is adjusted, opening of bag faces front.

Figure 13.

The Chinese Costume -

This requires a shirt, a pair of trousers, and a long coat. The coat must be full enough to conceal the bowl of water hanging under it without bulging. Bottom of coat should be weighted by sewing a metal chain or a small cloth tube filled with large shot into bottom hem.



Figure 14 shows diagram of arrangement of harness, bag, and bowl under performer's coat.

(49-4)



Figure 15 shows performer in Chinese costume as audience sees him.



The Production Cloth -

This cloth should be about five or six feet square, made of heavy, opaque, decorated material. The material should be such that it can stand wetting without spoiling. It is well to have a colored border around it. The back of cloth may be lined with plain-colored material, which helps to give it weight.

To Perform:

Come forward with all preparations made under your Chinese costume, and production cloth over left arm, as in figure 15. If bag is properly adjusted, you can walk freely. Chinese magicians even sit down on the floor and get up again while carrying bowl without exposing it.



Facing audience, take production cloth between both hands and spread it out. Show both sides.

Figure 16.

Fold up cloth, hit it with hands to show that it contains nothing. Replace cloth over left arm and make a complete turn around, ending by facing audience again. Take short, jumpy Chinese steps in making turn.

Now strike costume between your knees, pushing it in and say, "No". Then strike chest with both hands and say, "No". These two gestures show audience that you have nothing concealed in these places.



Open up cloth again as in Figure 16. Spread it out in front of you with the lower edge on the floor.

Figure 17.



Then drop cloth to floor. Pick it up and show both sides again. With cloth in front of you, squat down just far enough to touch concealed bowl to floor.

Figure 18 is a side view diagram of the movement.

When bowl touches floor, it is pivoted forward so that it is thrown to floor with top up.

(49-5)



Figure 19.



By a slight backward movement, release the bowl from the bag.

Figure 20.



Continue to move backward and cover bowl with cloth. Make some expressions which sound Chinese at this point.

Figure 21.



This series of movements is done quickly and to audience it appears that you merely squatted down a little and covered a large object which had suddenly appeared on the floor.

Reach down and grasp dangling ends of rope on bowl cover. Free cover from bowl quickly under the production cloth.

Figure 22.



With a flourish, raise up cloth with cover under it and expose the large bowl of water.

Figure 23.

Pour water from bowl into two buckets or glass dishes to show that bowl really contained water.

Some performers release cover from bowl in act of covering bowl with cloth and immediately raise cloth and cover without completely dropping cloth on floor.

Practice this effect carefully so that you overcome all clumsiness in your movements and can perform it gracefully and quickly. To the audience, who does not know of your movements, the production comes suddenly, in a flash.

(49-6)

PRODUCTION OF STACK OF FOUR BOWLS
OF WATER

This is very effective and puzzling. The bowls of water are produced in a stack and it seems hardly possible to handle them without spilling the contents.

EFFECT:

Performer's assistant stands holding a cloth. Performer takes it from him, and after showing it freely, places it on the floor. Suddenly cloth is raised and a stack of four glass bowls filled with water and containing goldfish appears in view.

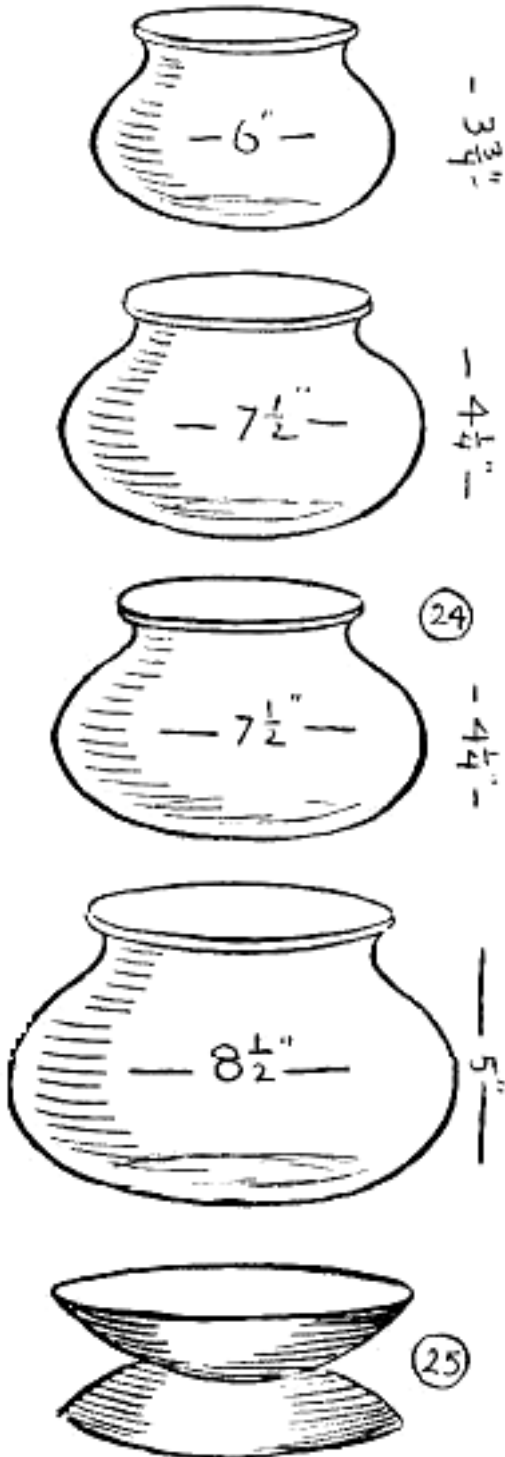
PARAPHERNALIA:

1 -- Four glass goldfish bowls as shown in Figure 24. The bowls vary in size so that they can be stacked with the largest one on the bottom and the smallest on top. The diameters of the bowls are given on the bowls and the heights are given beside the bowls in the diagram.

2 -- A metal base on which lowest bowl of stack rests. This can be made by cutting off the top of a metal cuspidor. Base should be shaped as shown in Figure 25.

3 -- A special cloth case to hold stack of bowls and enable performer to carry them in position and handle them easily.

4 -- A large opaque cloth, five or six feet square.



SECRET:

To Prepare:

The Bowls -

Fill the bowls about three-fourths full of water and place real or imitation goldfish into each one. Stack these bowls on the metal base.

Figure 26.

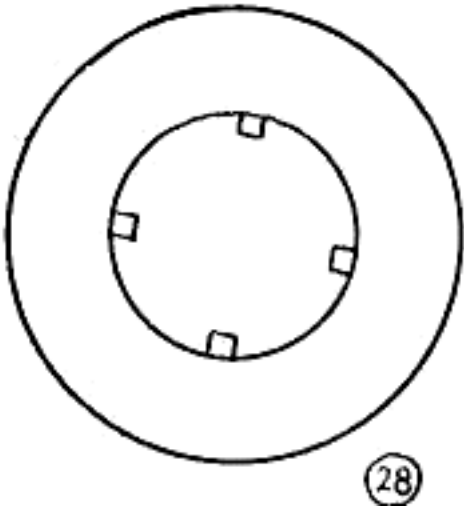
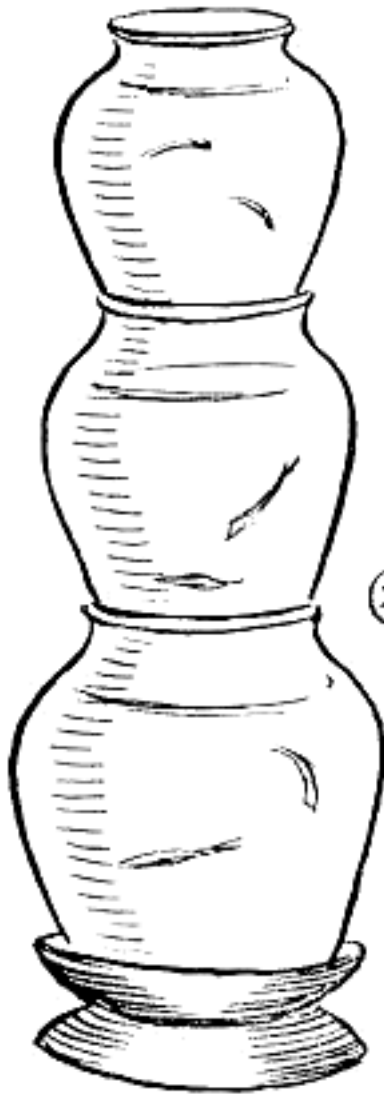
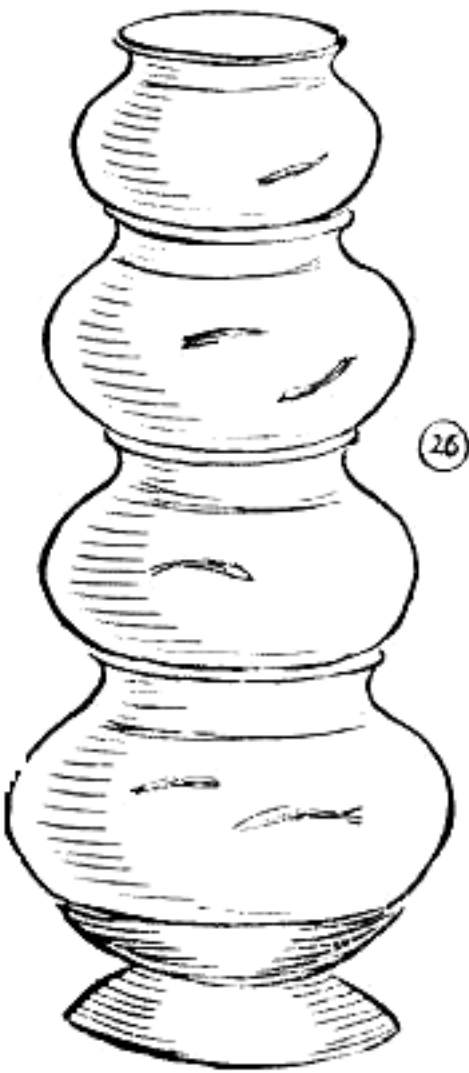
Prepare any other type of bowl which you may use the same way.

Figure 27 shows bowls of a different shape and height, requiring only three for the stack. Use whatever type of bowl you can secure.

Sometimes to keep the bowls from slipping, I glue four small squares of heavy cardboard to the bottom of all except the lowest one. This helps to fit each bowl snugly into the mouth of the bowl under it.

Figure 28 shows a diagram of the pieces of cardboard on bottom of bowl.

(49-7)



The Special Holder or Case -

Cut out a piece of heavy cardboard or bookbinder's board, about four inches square. Cut away the corners and cover it with black cloth. To the center of this, sew a small metal ring, A, about an inch in diameter. Ring A must be sewed securely all the way through the cardboard so that it will not pull out in lifting a rather heavy load. If necessary, use several thicknesses of cardboard glued together.

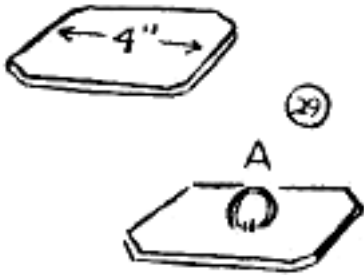


Figure 29.

Take a two-inch metal ring, B, and sew to it four folded strips of black cloth. Strips should be about two inches wide and folded in half. They should be long enough so that when they are attached to each corner of cardboard base, ring B can be raised two or three inches above base. Sew strips to each corner of cardboard base.

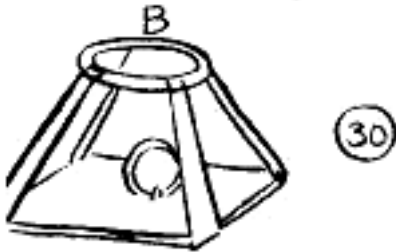
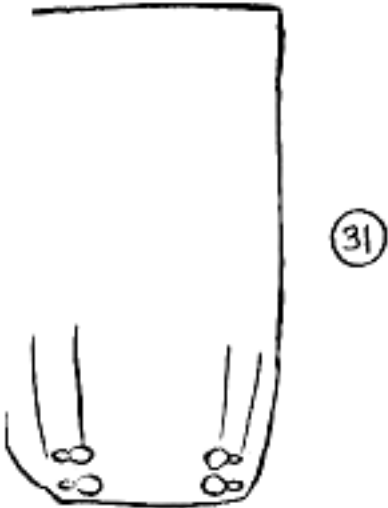


Figure 30.

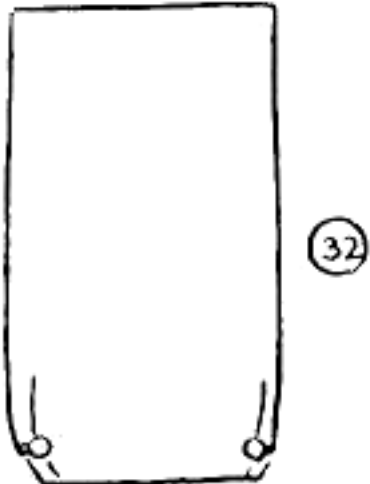
You next require two pieces of black cloth, each a little longer than the height of the stack of bowls and a little wider than half of the circumference of the bottom bowl.



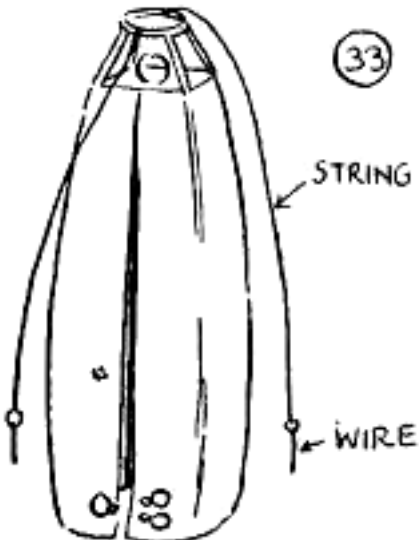
Secure some brass eyelets from a hardware store. These should be large enough to allow a fair-sized nail or piece of wire to go through. Sew four eyelets, two on each side of the bottom of one piece of cloth. Sew two eyelets, one on each side of the bottom of the other piece of cloth. When the two pieces of cloth are placed together, these single eyelets should be in such position as to come between the two eyelets. Take a few tucks in each piece of cloth to cup the bottom a little.

Figures 31 and 32.

Prepare another four-inch piece of heavy cardboard covered with black cloth as in Figure 29. Sew the tops of the two pieces of black cloth around this so that open edges overlap a little. Gather or fold cloth in to make it fit around covered cardboard. You now have a bag slit down at opposite sides.



Now sew cardboard top of this bag to cardboard base you have already prepared. See Figure 30. To opposite sides of ring B in line with the openings in bag, tie two pieces of fish cord about the length from cardboard base to eyelets at bottom of bag. Take two pieces of heavy wire long enough to go through the three eyelets and bend one end of each to form an eyelet through which fish cord can be tied. Nails may be used instead of wire in emergency. Figure 33 is a diagram of the holder as you now have it prepared.





Place the case over the stack of bowls on metal base so that bottom of case comes to narrow part of base. Allow ring B to drop down so that you can insert wire through the three eyelets at each side of case. Bottom of case should fit snugly around narrow part of metal base.

Figure 34.

(49-8)

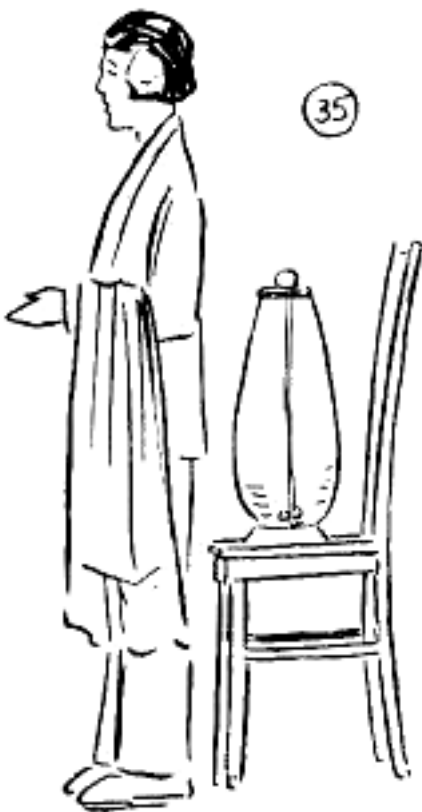
Now if holder is lifted by ring A, the whole stack of bowls can be easily handled and carried about. Then if ring B is lifted, it pulls the cords up bringing the wires out of the eyelets and releases the stack of bowls from the case.

I cannot give you exact dimensions on the holder for you must fit it to the size of bowls you use. Experimenting will teach you the size to make the holder and the length of cords to use for proper carrying and proper release. There are various holders which you might use, but this one is the simplest and best I know of.

To Perform:

This is a fine opening number. When it is used as such, stack of bowls in case are placed on the seat of a chair near center of stage. Girl assistant stands directly in front of stack of bowls. She holds production cloth over her left arm to help screen object behind her.

Figure 35 is a side view of position of girl in relation to object on chair.

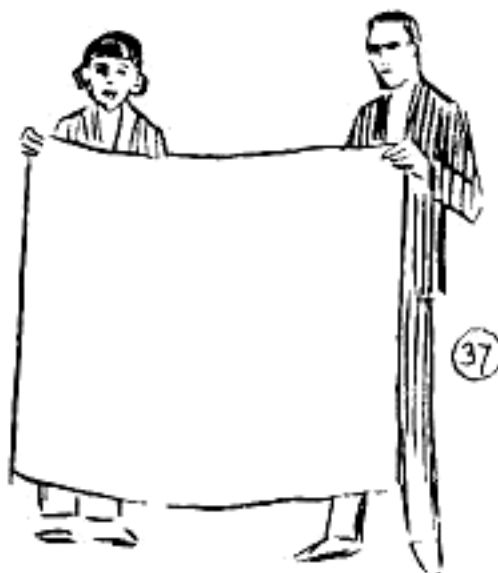


Step up to left side of assistant and take one corner of cloth from her arm. Have her hold other upper corner.

Spread cloth out between you to show one side of it.

Figures 36 and 37.

Push your right hand into center of cloth from behind and grasp cloth at that point from the front with left hand.





Allow cloth to hang down from center with edges touching floor.

Figure 38.

Lift cloth up from floor as though expecting something there. Seeing nothing, throw cloth into air a little way and as it comes down bunch it together suddenly with both hands. In this way, you indicate to audience that there is nothing concealed in cloth.

Spread cloth out again, showing both sides to audience. Then hold it between yourself and assistant as in Figure 36. Hold your corner of cloth with left hand so that right hand is free behind cloth. The moment girl takes opposite corner of cloth reach over to stack of bowls with right hand, lift them in case by ring A, and bring them behind cloth.

Come to position shown in Figure 37. To audience your movements with cloth are the same as before.

Now bring right hand with bowls behind center of cloth and take hold of center of cloth from the front with left

39



hand as you did before--but this time grasping ring A of holder through the cloth in left hand. Allow cloth to hang from left hand as before but this time the stack of bowls is concealed under it.

Figure 39.

Let edges of cloth come down on floor until bottom of stack of bowls is firmly on floor. Then release hold on ring A and pick up ring B through cloth.

40



The lifting of ring B releases the wires from the eyelets and cloth case is freed from metal base of stack of bowls. Suddenly pull up cloth with the case concealed in it and reveal the stack of bowls on the floor.

Figure 40.

41

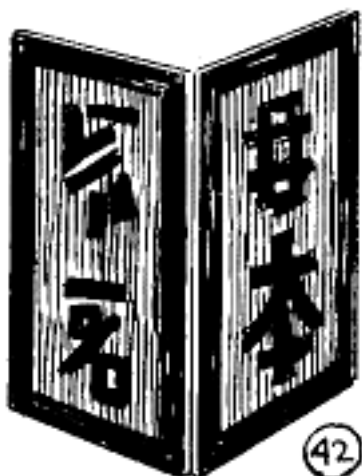


Assistant brings a decorated pail and you pour the water from each bowl into the pail to show that the bowls are separate and that they each contain water.

Figure 41.

To Produce Stack of Bowls During Performance -

It may be at some time that you will want to produce the stack of bowls as the climax to some effect during your performance. It makes a good climax, for instance, to a silk production.



42

After you have produced a bunch of silks from a hat, a Chinese lantern, or something else, you can pick up the silks and place them on a bare table. Then suddenly lift the silks and produce the stack of bowls. The effect is very startling.

To perform this, build a small two-sided screen a few inches higher than the stack of bowls.

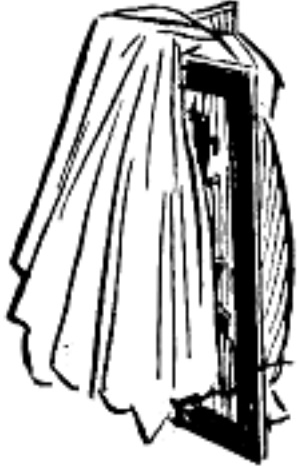
Figure 42.



43

Place this screen somewhere on stage and place stack of bowls in case behind it.

Figure 43.



44

As you produce silks, place them one at a time over the screen letting one edge fall over top of bowls.

Figure 44.

(49-10)



After production is finished, quickly pick up the silks, at the same time grasping ring A of case over bowls. This brings stack of bowls up behind silks. Do this in a natural manner as if you were merely lifting up the silks.

Figure 45.

Bring silks over to table and set stack of bowls down on table without revealing it to audience. Through the silks, grasp ring B and raise it to release holder. Then suddenly lift up silks with holder concealed behind them and expose stack of bowls on table.

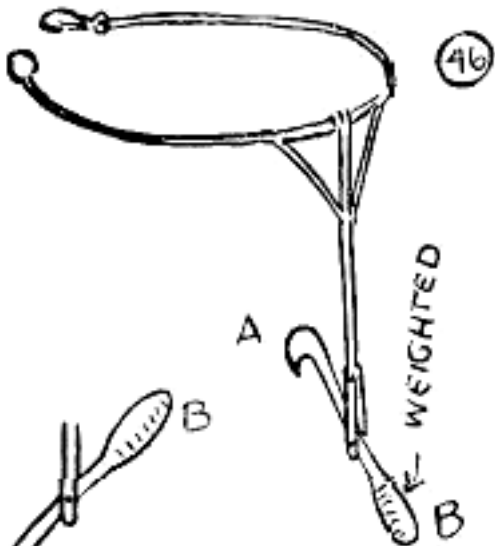
NOTE:

When this production is performed from a bunch of silks, it is well to make the case for the bowls bright red in color to match some of the red silks. Thus even if case is accidentally exposed, it would not be noticed by audience because it is the same color as the red silks.

* * * * *

CHINESE PRODUCTION OF THE FOUR BOWLS

This experiment is similar to the Production of a Large Bowl of Water except that performer produces the stack of four bowls instead of the one large bowl.



SECRET:

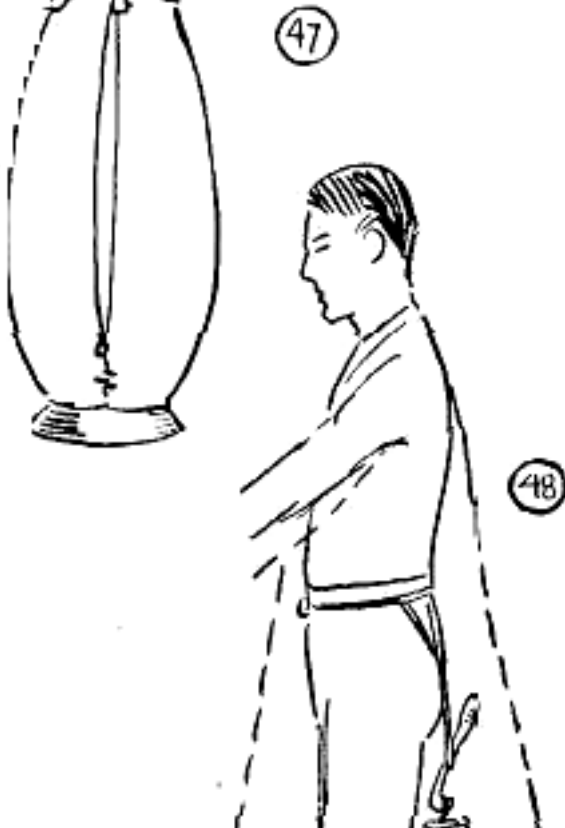
A fair-sized load of bowls can be produced by this method in which a special type of harness is used. This consists of the belt and suspended rope. At the end of the rope is a metal contrivance. This is a flat metal piece with a hook at the front end and weighted at the other end so that when nothing is attached to it, A goes up and B goes down. Through the middle, a hole is bored and a bar run through so that contrivance can pivot up and down. This bar is supported on both sides by metal pieces also.

Figure 46.

Place the case around stack of bowls and then hang ring A on hooked end of harness--A.

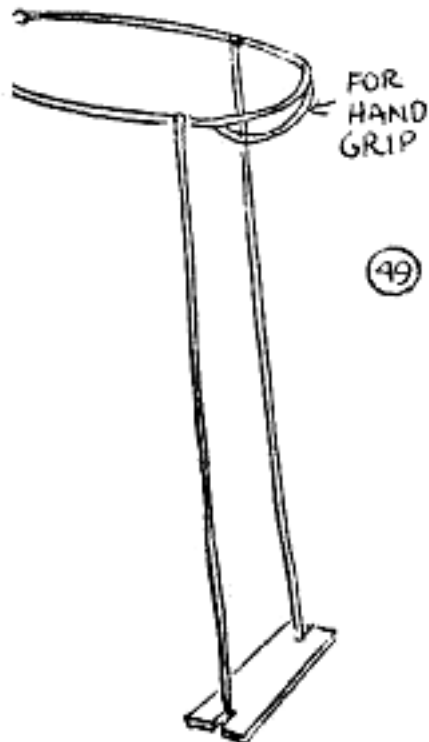
Figure 47.

Figure 48 is a diagram of harness and stack of bowls adjusted under Chinese coat.



Now, when you squat down until stack of bowls rests on floor, you can move forward slightly with just your body to release hook A from ring A. Production is performed in same manner as first effect in this lesson with the production cloth. Under cover of cloth, case is removed from stack of bowls by lifting ring B.





SECRET:

49

The apparatus used in this production is a swing arrangement. Attached to the belt are two lengths of rope with a board base, on which child crouches. Another small piece of rope is attached to back of the belt which child can hold on to with hands. In place of this a piece of rope may be hung from around performer's shoulders for child to hold to.

Figure 49.



50

Figure 50 is a side-view diagram showing position of child under Chinese coat. Cloth is held straight up in front of performer to screen production.

When ready, performer gives a signal to child, who throws feet forward on to floor between performer's legs. Then child comes out from under performer's coat and stands erect in front of him. Performer removes cloth and reveals child.

* * * * *

MODERN PRODUCTION OF BOWL OF WATER ON TABLE

This production is adapted for the performer who works in American style clothing and has no room under his clothes for concealing a bowl of water. This is a good opening number if done with pep. It is very easy to do, yet appears most difficult and mysterious.

EFFECT:

After showing production cloth on both sides, performer throws it over his left arm. Suddenly he seems to catch something in his arms—it appears to be a very heavy object. He goes over to table and places object on it. Then production cloth is removed and large bowl of water is found on the table.

PARAPHERNALIA:

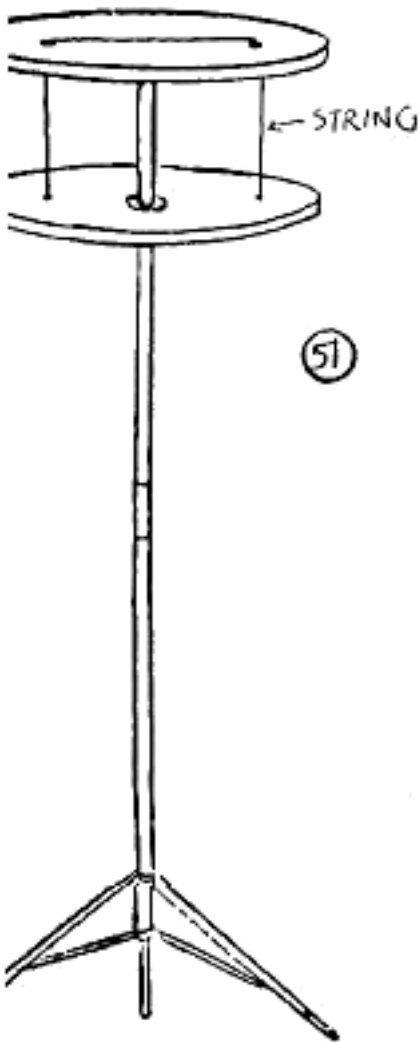
- 1 -- A special table.
- 2 -- Bowl of water.
- 3 -- Opaque, heavy cloth, four feet or more square.

SECRET:

To Prepare:

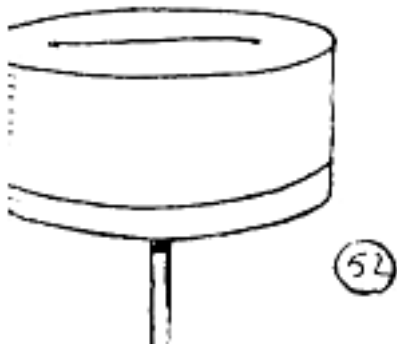
The Special Table -

This consists of a metal or wooden base with a middle rod running up to table top. At top of rod there is a metal flange to which black table top is screwed. Under this top there is a secondary top with a hole in the center large enough



to slide up and down the middle rod of table. Holes are bored in both of these tops, through which cord is run. This cord goes across the upper table top and is knotted under each hole in the secondary table top. Enough cord should be allowed so that secondary top can drop several inches below first one. The purpose of this cord is to pull lower top up against upper one.

Figure 51.



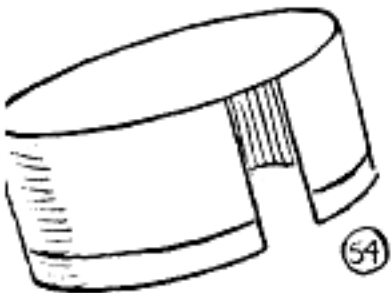
Attach a strip of velvet around the table between edges of upper and secondary table tops. Sew a strip of gold braid near the bottom. This gives appearance of an ordinary draped table.

Figure 52.



The bowl of water you use must be the same size in diameter as the table top. In designing your table, plan it according to the size bowl you wish to produce.

Figure 53.



Now make a special velvet cover to go over bowl. The top of this cover is black velvet and the sides are the same color as the table drape. Trim this cover with gold braid as you did the table drape as the two must look identical. This cover must be a little higher than the table drape so that it will cover bowl and come down to lower edge of secondary top when it is pulled up against upper top. Cover has a two-inch opening in the rear so that it can be easily slipped off the bowl.

Figure 54.

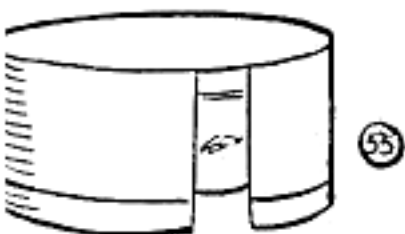
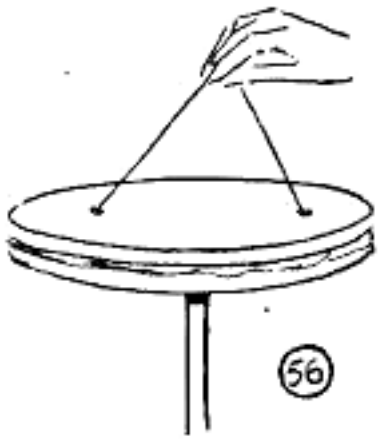
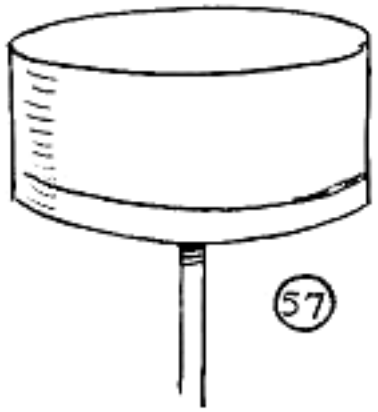


Figure 55 shows cover over bowl of water—rear view away from audience.



Now to arrange for effect, pull cord up on first table top so that secondary one comes up tight against it. The velvet drape is tucked between the tops.

Figure 56.



Bring taut string down on table top and place bowl of water over it. Bowl will hold string in place and keep secondary top up against upper one. Now place cover over bowl and let it drop down to cover table tops. Opening of cover is at rear.

Figure 57 shows table as audience sees it.

(49-13)

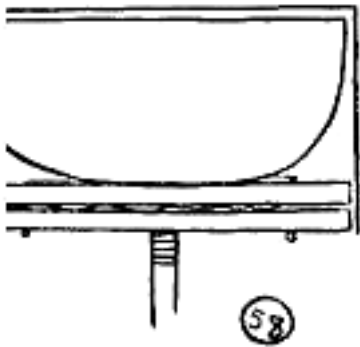


Figure 58 is a cross-section diagram of arrangement under cover. The two table tops are tight against each other with velvet drape tucked between them. Taut string is held in place above table by bowl of water on it.

To Perform:

Pick up production cloth, show both sides, and run it through your hands. Then show both sides again.

Figure 59.



Throw cloth over left shoulder and arm. Suddenly drop body downward a little as though you had caught something heavy in your left arm under cloth. Curve left arm under cloth to make it look as though it was encircling some object.

Figure 60.



Raise arm and left side of body and walk to table as though carrying something heavy. Stand in front of table with left side turned to audience. Cloth completely screens table from view of audience.

Figure 61.



Hold cloth with left arm and hand, releasing right hand behind cloth. Remove cover from bowl of water on table and take cover in left hand under cloth.

Figure 62 is view away from audience.





Pick up bowl of water a few inches with right hand. This frees cord and causes secondary table top to drop below upper one, stretching the velvet drape out between them. Replace bowl on table. Then suddenly remove production cloth with velvet cover concealed in it, and reveal bowl of water.

Figure 63.

The difference in height of table is not noticed by audience and to them it appears that table is the same as it was in the beginning. It seems that the bowl of water appeared from the air.

* * * * *

THE VANISHING BOWL OF WATER

This is a pretty effect and easy to perform.

EFFECT:

Performer fills a bowl with water and places bowl on tray held by assistant. He places a cloth over the bowl, then picks up the cloth with the bowl and tosses them both into the air. When he catches the cloth, the bowl has vanished into midair.

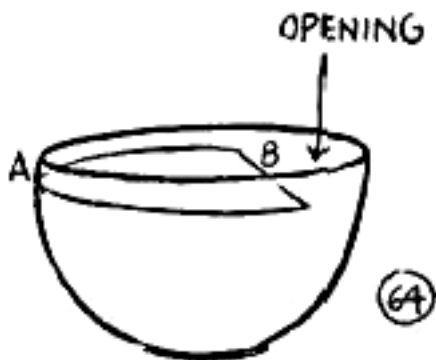
PARAPHERNALIA:

- 1 -- Special metal bowl and tray.
- 2 -- Prepared cloth.
- 3 -- Pitcher of water.

SECRET:

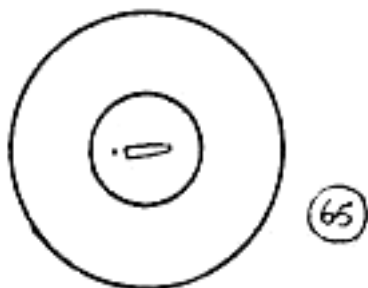
To Prepare:

Special Metal Bowl and Tray--



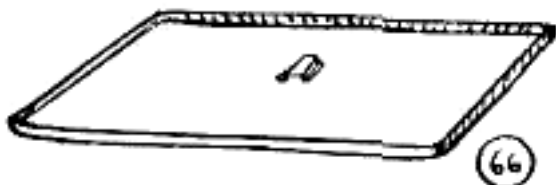
This bowl is of metal painted white. It has a piece of metal, also painted white, soldered in about half an inch from the top. This piece does not cover top of bowl, allowing an opening into which water can be poured. Edge B of metal piece should be lower than edge A so that any water which happens to come on top of it will drain down into bowl.

Figure 64.



On bottom of bowl a narrow strip of metal is soldered on at one end. The other end is narrowed down to a blunt point.

Figure 65.



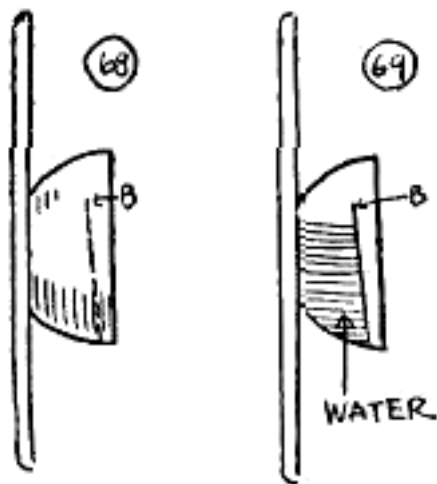
A metal tray is used and to the center of this is soldered a small piece of metal into which strip on bottom of bowl fits.

Figure 66.



When bowl is placed on tray and adjusted into catch, it can be held up on end without slipping off.

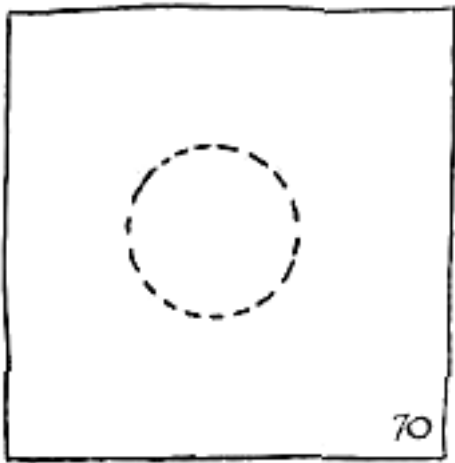
Figures 67 and 68.



Water can now be poured into bowl on tray. Tray can be tipped and water will not spill, providing end B of metal piece in bowl is kept uppermost.

Figure 69.

Special Cloth--



A double opaque cloth, two feet or more square, with a special ring of metal, cardboard, or celluloid sewed between the two sides. This ring should be same size as rim of bowl. A round piece of flat transparent celluloid is good for it cannot be seen even if light shines through the cloth. However, it is not necessary if cloth is heavy and opaque. To audience, this appears to be just an ordinary cloth.

Figure 70.

To Perform:

Assistant is at your right holding tray with bowl on it. Pick up bowl and turn it upside down, being careful not to

(49-15)



expose metal piece inside. Then replace bowl on tray, fastening it securely into catch. Have opening of bowl nearest audience.

Pick up pitcher and pour water into bowl. Amount of water must be judged by size of bowl and amount you can pour in without having it spill when bowl is tipped. Place pitcher aside. Then pick up cloth and hurriedly show both sides.

Figure 71.



Place one edge in back of bowl and cover bowl, thus allowing bowl to be visible as long as possible while being covered. Circular piece in cloth should come directly over top of bowl.

Figure 72.



Lift circular piece in cloth between both hands as though you held the bowl under cloth. Ends of cloth hang down, giving impression of covering bowl. As soon as you have cloth raised a little, assistant turns tray with bowl attached so that bottom faces audience and bowl is concealed behind it.

Figure 73.



You carry cloth away a short distance as though carrying bowl under it. Assistant leaves stage with tray, carefully keeping bowl concealed.

Figure 74.

(75)



Throw cloth up into air as though tossing bowl with it. When cloth comes down, grasp the two nearest corners in each hand.

Figure 75.

(76)



Let cloth fall down spread out between hands, showing that bowl of water has vanished. Show cloth on both sides and put it aside, being careful not to expose shape of ring inside.

Figure 76.

(49-16)

This production is not only adapted to doves but to other small animals or objects. The apparatus may also be made large enough to produce a large duck or chicken.

EFFECT:

Performer shows an empty pan or bowl and covers it for a moment with a board. Then he raises the board, and two doves fly out of the pan.

PARAPHERNALIA:

1 -- Two wash basins - usual size is about 10 1/4 inches.

These must be the same size so that one will fit snugly into the other.

2 -- Special top for wash basin.

3 -- A board - about 1/4 inch thick and 14 to 16 inches square.

4 -- Two doves.

SECRET:

To Prepare:

The Pans -



Both pans should be lacquered or painted a bright red inside. The outside and top edge of one should be painted a dead black and then strips of cloth or felt pasted on it to deaden the noise when it is placed inside other pan.

Figure 77.



Other pan is painted a bright green on outside, or some other bright color, with top edge and a border of black. Chinese characters in black and gold or just black decorate the outside.

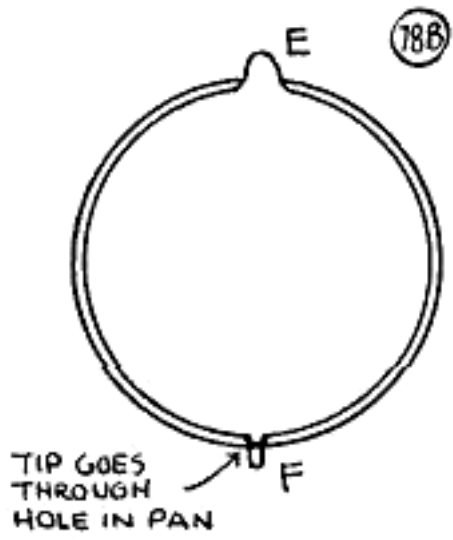
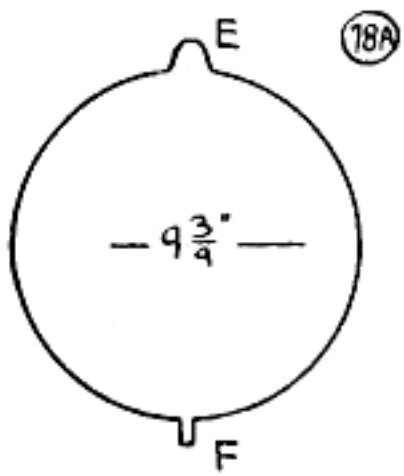
Figure 78.

The two pans should look like one when placed together and the black edges at top help this illusion.

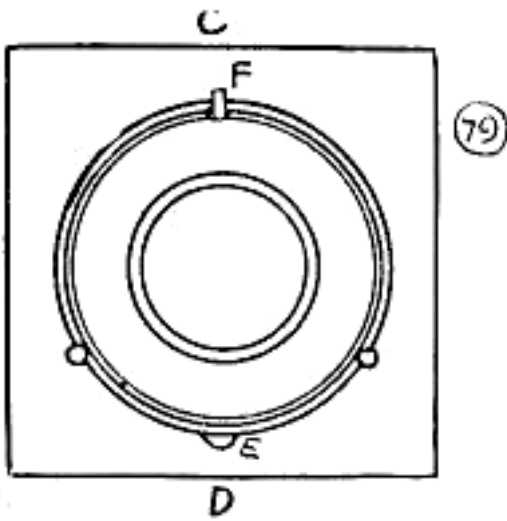
Special Top -

This top is a circular cover to fit over pan A. It is 9 3/4 inches in diameter and is made of silicate or metal, covered with felt to prevent noise. A heavy cardboard top may be used in emergency. At each side of top, there is a tip. F is made narrow to fit into hole in top of pan (all wash basins have a hole in top for hanging). E is wider and extends over other side of pan.

Figures 78A and 78B.



The Board -



79

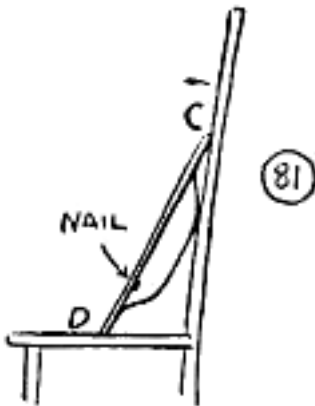
Board may be decorated or left plain. On back of board about one-third the distance from one edge, drive two nails about nine inches apart. Nails should be short and allowed to extend from board about three-sixteenths of an inch. Heads of nails should be about three-eighths of an inch in diameter. Now when pan A is slipped under nails on back of board, opening to board, it is held securely in place.

Figure 79.



80

Figure 80 shows pan in relation to board.



81

Place the two doves in pan A and adjust the special top over pan as in Figure 78B. Place pan on board with edge resting under nails. Have E of special cover pointing down and F up. Place board with pan behind it on chair, resting one edge on seat and other edge against back. C edge of board with F tip of special cover are up.

Figure 81.



82

To Perform:

Pick up pan B and show it on all sides. Hold it in left hand with opening toward audience and strike bottom of it with right hand. Then pick up board from chair with right hand, holding it with thumb over top edge toward audience.

Figure 82.



83

Bring pan B up behind board and place it over pan A.

Figure 83.



84

Turn board to horizontal position with pans under it. To audience it appears that you merely picked up an empty pan and covered it with board.

Figure 84.



Move board slightly to left to release pan A from nails. Support pans with left hand and raise board enough to get left thumb on top of tip E of special cover. You do this to keep cover securely over pan A so that doves cannot escape. Tip pans toward rear so that cover is not visible to audience and remove board. The two pans are held as one.

Figure 85.

Look at pans as though you had expected something to happen, then shake your head. Turn board around and look at both sides. Then look up into air.



Cover pans with board again and shift hold on tip E so that fingers press it against board. Turn your right side toward audience. Now support pans with right hand. Remove board again and this time carry special cover with it. Tip E gives you enough grip to do this easily. Turn board quickly to conceal cover behind it. When board and cover are removed, move pans enough to cause doves to fly upward.

Figure 85A.

THE MYSTERIOUS SELF-FILLING LOTA

This effect is usually credited to the Hindus but it is performed by the Chinese also.

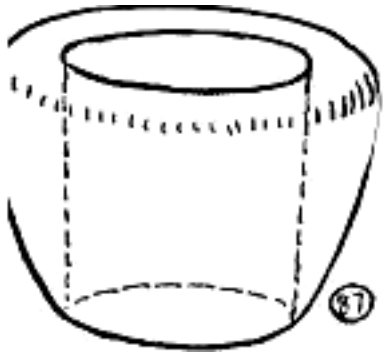
EFFECT:

A lota, or bowl, is filled with water. Water is then poured out into a bucket or jar and lota shown empty. Performer states that he will cause water to flow from his eyes or his ears. He places his eyes down on top edge of lota for a moment and then pours more water out of lota. Next he places the lota to his ear and again water is poured out of lota. He may cause water to flow into the lota from his elbows also. Each time lota is apparently emptied.

86

PARAPHERNALIA:

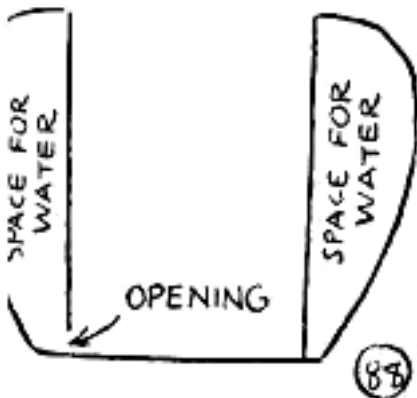
1 -- A special lota. We can supply you with this. Lotas are made in a variety of shapes, but the one usually used is shaped as shown in Figure 86.



Its secret lies in the fact that it can be shown empty while secret compartment holds water. A cylindrical tube extends from the mouth of the lota to the bottom, thus making two compartments -- one inside of the tube and the other all around the lota between the tube and the outside. Inside of tube is painted dead black so that when audience sees it, it appears to be inside of lota.

Figure 87 is a diagram of the arrangement of lota.

OPENING



In the bottom of the tube there is a hole, an eighth to a quarter of an inch in diameter through which secret compartment is filled. At top edge of lota there is another hole through which air enters causing enough pressure to cause water to flow from secret compartment into tube.

Figure 88 is a cross-section view of lota.



89



90

Figures 89 and 90 are cross-section views of lota filled with water and of lota apparently empty but with water in secret compartment.

To Prepare:

The Oriental performer either has his lota already filled with water or he brings it out empty and submerges it in a bucket of water to fill it. To save time in our modern-day performances, however, it is well to have lota filled beforehand. To fill it, submerge in a pail of water and give it enough time to fill properly. Then remove lota and wipe off outside.

Here I shall teach you the Oriental presentation, but you can easily adapt it to modern patten and performance, if you desire.

To Perform:

Bring filled lota forward.



Pour water from tube in lota into pail. To do this, turn opening of bowl toward audience and then down. Turn bowl upright and then down again as though to empty last few drops forcefully. As you do this, be sure to keep thumb or finger over air hole at upper edge of lota.

Figure 91.

Now hold lota in left hand, releasing finger from air hole and bring lota to upright position again. Water will flow from secret compartment into tube until the level is equalized.

Look up into air and make a gesture upward.



"Water up high -- clouds, rain. Water, too, in ears (point to ear) -- eyes (point to eyes) -- elbows" (show elbow).

Bend head over to right side and hold lota up to ear with both hands. Hold position for a few moments.

Figure 92.

"Ear, much water."

Empty lota into pail, shaking it dry. Bring it upright again and water will flow into tube from secret compartment.



Now bend head forward and hold lota up to eyes for a few moments.

Figure 93.

"Water from eyes."

Pour water into pail, then bring upright and water will again flow into tube.

This time place lota against bared elbow and hold for a few moments.

"Water from elbow."

Pour water from lota into pail.

Each time there is less water to pour out, but you can continue the production of water as long as it makes a good showing.

Lota Comedy -

Some performers use the lota effect as a comedy adjunct to their acts. After performing an experiment, performer goes over to table and picks up lota, then empties. He proceeds with another effect and then empties lota again. He continues to do this several times between effects with excellent comedy results.

Edwin Brush, the well-known magician, works the lota effect by pouring six glasses of water from it. He pours the six glasses back and finds that this time the lota is filled to overflowing. It appears that he has produced much more water than the lota originally held. In pouring water back into lota, it is necessary to keep air hole covered with thumb so that water will not go into secret compartment readily and thus overflowing effect can be produced. Also if you desire to keep water in tube, fill lota speedily and water will not have much time to get into inner compartment. If hole in tube is too large, plug it with magician's wax.

* * * * *

CHING LING FOO'S MAGIC WATER CAN

This was an interesting number on Foo's program. His sense of showmanship and presentation added to the interest.

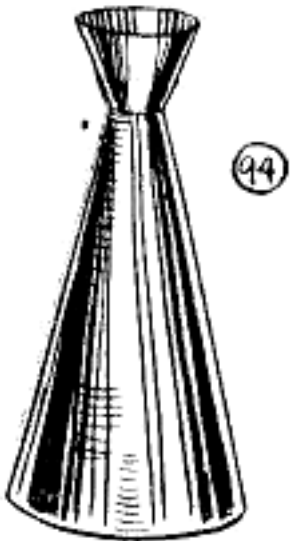
EFFECT:

Performer shows a Chinese can, narrow at the top with a funnel edge. He turns it upside down and spins it on his wand, then suddenly pours water out of the can. He repeats this several times, showing the can empty, yet pouring water from it at will.

PARAPHERNALIA:

1 -- A Ching Ling Foo Water Can. We can supply this.

Figure 94 shows can as it looks to audience.

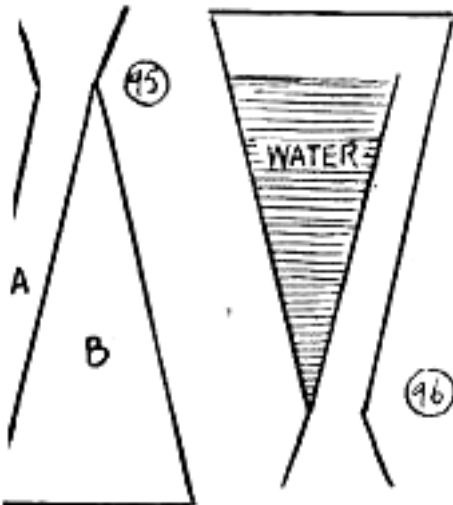


Figures 95 and 96 show cross-sections of can. Notice the two compartments A and B. When can is upright as in Figure 95 and water is poured into it, water goes down compartment A and levels itself between compartments A and B. Then if can is tipped with A up and B down, water will go over into compartment B. If turning of can is continued until bottom is up, all the water will be held in compartment B. Thus when can is upright, water can be poured out of it and when it is bottom up it is apparently empty for no water comes out of it.

SECRET:

To Prepare:

Place the necessary amount of water in can to fill B when can is turned over. Should there be any excess, it would do no harm as it would run out when can is turned over and can may be shown empty after that.



To Perform:

Pick up can and turn it over so that water will all go into compartment B. Put end of wand into A and spin can around on wand.

Figure 97.

(49-21)



98



Remove wand from can and strike outside of can with it several times. Now turn can upright. Strike it again several times with wand, then reach up into air with wand and bring tip of it down to top of can. Turn can over and pour out a little water.

Figure 98.

Repeat routine, varying it a bit here and there for additional interest, and pour out water at will.

* * * * *

MYSTERY OF THE PAPER BALL, EGG, FROG, AND BABY CHICKEN

This is typically a Chinese effect and most interesting for the magician in the Orient who plays in the open. However, it can be adapted for American or European performance with good effect. The effect is usually done on the ground, but I teach it to you here for performance on a table.

EFFECT:

Two, three, or four soup bowls are on the table, tops down. Performer casually turns two of them up, looks inside, and replaces them on table. He then rolls a piece of tissue paper into an inch-size ball and places this on table over to right. Picking up a bowl in each hand, he places left-hand bowl down on table to left and covers ball of paper with right-hand bowl. He says that he will cause the ball to jump over to the opposite bowl, but on lifting the bowls, it is seen that ball is still in the same place. Magician then places right-hand bowl aside. Saying that he will make the ball jump, he picks it up with his right hand and places it under the left-hand bowl. In a moment left-hand bowl is lifted, and the ball has mysteriously changed into an egg. Egg is then covered with bowl and uncovered again, only to have changed into a frog. Explaining that the egg did not hatch right, magician covers the frog and when he uncovers it, out comes a baby chicken in its place.

PARAPHERNALIA:

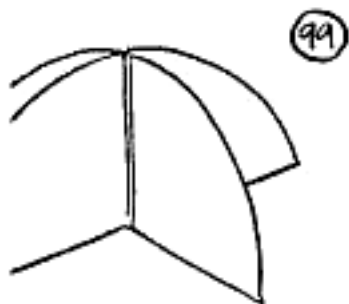
- 1 -- Two or three metal bowls, shaped like high soup bowls.
- 2 -- A special soup bowl, the same in appearance as the other bowls, but specially prepared inside.
- 3 -- A piece of tissue paper about six inches square. An egg, a frog, and a baby chicken. A ball of cotton or some other object may be substituted for the frog. Or two baby chickens may be produced -- one black and one white.
- 4 -- An undraped table.

SECRET AND PATTERN:

To Prepare:

The Special Bowl -

Study the illustrations carefully and you will have no difficulty in understanding the principle on which the working of this bowl is based.



Inside of the bowl there is a special metal insert with four wings, which separates the bowl into four compartments. Through the middle of the insert runs a small tube to pass a wire through.

Figure 99.

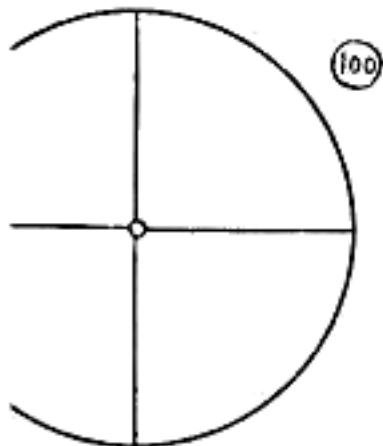
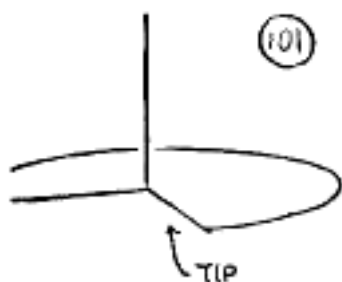
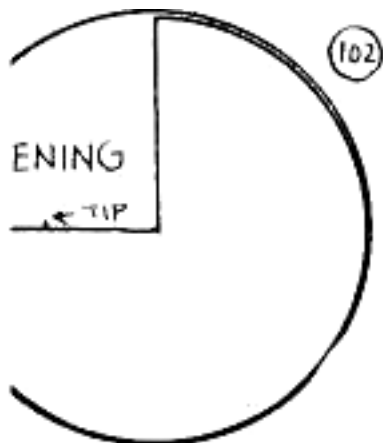


Figure 100 shows a view from mouth of the bowl with metal insert soldered into bowl. Here you see the four partitions and middle tube. The partitions should fit snugly against sides of bowl and should come down within about half an inch of top edge.



A special circular cover is made of metal to fit just inside top of bowl over metal insert. One quarter-section of this cover is cut out so that only three compartments are covered. A wire is soldered to center of cover so that it extends straight upward. On one edge of cut-out section, there is a small tip, like the point of a pin, extending downward about a sixteenth of an inch.

Figure 101.



Cover is placed over metal insert in bowl so that wire extends upward through middle tube. A hole in bottom of bowl comes directly over tube so that wire can extend up through bottom of bowl. On outside of bowl, wire is bent over, or, better yet, cut off close to bowl and a flat button soldered over end to keep wire and cover from falling out.

Figure 102 shows a view from mouth of finished bowl. Cover is in place with one section open and the little tip extending away from inside of bowl.

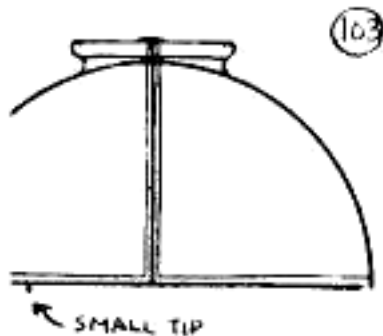
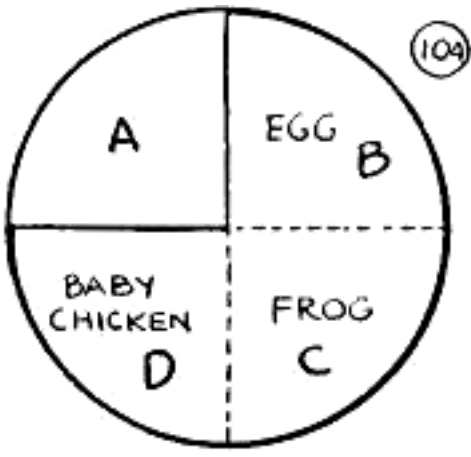


Figure 103 shows cross-section view of finished bowl, bottom up. When bowl is placed on table in this position and is turned while held firmly on table, the small tip will catch in table or tablecloth and will keep the cover from turning. Thus while bowl is turned, cover remains stationary, and any section of bowl can be brought over opening of cover.

A different Chinese character should be placed on outside of bowl opposite each compartment so that you can quickly locate each object you have inside merely by looking at outside of bowl. Bottom of bowl should have a character painted over the button to help conceal it. Unprepared bowls should be decorated in the same manner.



Now before performing. Have opening of cover over compartment A, then turn it over compartment B and place an egg in this compartment. It is well to line B with felt to prevent rattling of egg. Next turn opening to C and put the frog in. Turn to D and put the baby chicken in. Finally turn cover back with opening over A.

Figure 104.

Arrange the bowls, bottoms up, on right side of table with an unprepared bowl first, the prepared one next, and finally

the other one or two bowls. The purpose of having these unprepared bowls is misdirection.

Place tissue paper in pocket.

To Perform:

Pick up first bowl and look inside, perhaps blowing out a bit of dust. Let audience see inside of bowl without calling attention to it. Replace on table.

Pick up third bowl and go through similar procedure. Pick up fourth bowl, if you have a fourth, in left hand and place mouths of two bowls together, allowing audience to see insides as you do so. Then replace bowls on table.



Take piece of tissue paper from pocket, roll it into ball, and place on table a little to the right. Pick up prepared bowl in left hand, being careful not to expose prepared inside. Pick up first unprepared bowl with right hand, lifting it higher and showing inside-Figure 105.

"I place one bowl here."

Place left-hand bowl on table at left.

"And the other bowl over this ball of paper."

Cover ball of paper with right-hand bowl.

"The ball will jump from under this bowl to this one over here. I say one - two - three - jump."

Lift left-hand bowl, revealing nothing. Lift right-hand bowl, showing paper ball still on table.

"He did not jump. Funny - he usually jumps."

Place right-hand bowl aside on table.

"Maybe he wants me to help him jump."

Pick up ball of paper in right hand and place it under left-hand bowl. Place ball on table so that all can see it, then cover with bowl so that compartment A comes directly over it. Turn bowl on table to right far enough to swing cover over compartment A with the ball and expose compartment B with the egg. Raise bowl in left hand, revealing the egg on the table.

"No wonder the ball of paper would not jump. He was just going to hatch into an egg."

Pick up egg and show, replacing it on table. Cover egg with bowl so that opening of cover comes over it. Then turn bowl to right again far enough to cover compartment B with the egg and expose compartment C with the frog. Lift bowl, showing frog.

"Egg hatches to frog. Not so good. Not such a good egg. Let's try it again."

Cover frog with bowl. Turn bowl to cover compartment C with frog and expose D with the chicken. Lift bowl again and show the baby chicken. This makes a very pleasing ending for the experiment.

* * * * *

REVIEW

Lessons 38 to 49

It is time now for you to go back and review once more. Do you realize what a vast fund of information and what a thorough education you have gained in Magic up to this point? If you don't, a complete review will bring it home to you with great force. And if you do, this review will give you a tremendous satisfaction in the knowledge of the big thing you have accomplished.

Turn back to Lesson 13 for the first section of your review, Lesson 25 for the second section, Lesson 37 for the third section, and finally to this lesson for the fourth section.

This outline covers Lessons 37 to 49:

Lesson 37 -- Oriental Magic, including the principles of many mysterious knots and ties and of cut and burned tapes.

Lesson 38 -- Oriental Magic continued, giving you my original Japanese thumb tie -- principles of a chemical trick -- an effect with sticks -- an effect with balls -- principles for productions and vanishes in a grain trick -- an excellent lantern production. In this lesson you learn Chinese, Japanese, and Hindu Magic.

Lesson 39 -- A variety of principles and effects in Handkerchief Magic -- some original with me and some used on the programs of the world's best magicians. Color-changing handkerchief, dyeing silks, and flag effects in this lesson.

Lesson 40 -- Important discussion of Character Analysis in relation to Magic. Also effects with handkerchiefs, flags, ribbons.

Lesson 41 -- The wonderful principles of Billiard Ball Manipulation with excellent effects, utilizing these principles.

Lesson 42 -- Novelty ideas for inexpensive magic, presented in original effects by Arthur Pope, Cardini, Bert Douglas and myself. Included are color-changing handkerchiefs, billiard ball combinations, fruit and candy effects, as well as the famous Popping Corn in a Hat.

Lesson 43 -- Great principles for coat and hat productions. Rabbits, of course, as well as other objects.

Lesson 44 -- Chemical and Mechanical Magic. The famous wine and water effect and cooking magic are included. Valuable principles for novel magic explained.

Lesson 45 -- Spiritualistic Magic, teaching you principles used by spirit mediums as well as magicians. How to perform a seance explained.

Lesson 46 -- Continuation of spirit magic, giving dark seances, thought projection, cabinet seances, and a chain escape.

Lesson 47 -- Principles and routines of the Linking Rings used by Laurant and Namreh.

Lesson 48 -- Principles on which the world-reknown Hindu Mango Tree Growth is based -- also other plant growths, an effect by Kolar, and my own mysterious Hindu Plant Growth and fire-cracker effect are included.

Lesson 49 -- Wonderful Chinese Magic, presented in this lesson.



TARBELL SYSTEM, INCORPORATED, Chicago.

* * * * *

Additional paraphernalia described in this lesson for replacement, etc., can be obtained from the Tarbell System at the following prices, postage prepaid.

Self Filling Lota \$5.50

Ching Ling Foo's Water Can 1.25

* * *

LESSON 50

THE FAMOUS TARBELL ROPE MYSTERY which has created such a sensation in the magic world. Magicians say that this is one of the greatest effects ever brought out. If you received nothing else but this ingenious rope mystery, you would have very much more than your money's worth. It is one of the finest reputation builders in modern-day magic.

It was my original intention in writing this course to make it fifty lessons in length. However, as I progressed with the lessons, I found that fifty would not be enough to cover all the wonderful material I want you to have. I have, therefore, extended the course and the following lessons will include illusions, information on advertising, and stage presentation.

This lesson reveals to you the great secrets of one of the finest magical effects which I have ever created:

THE TARBELL ROPE MYSTERY

It is with a great deal of pleasure that I disclose to you the secret and presentation of my famous rope mystery. This effect has been a fine reputation-builder for me, and I want it to be the same to you.

This mystery has puzzled audiences time and again, and even magicians have found it utterly baffling. Some of the finest newspaper men in the country have seen me perform it and have admitted their complete bewilderment. It has received more comment, perhaps, from the magical fraternity than any other effect in twenty-five years. Thurston, the famous magician, stopped his show in Milwaukee at one time to have me present the rope mystery to his audience. Houdini, Laurant, Reno, and others have done the same thing. Each time it sent the audience away talking about this peculiar Hindu mystery.

I tell you these things because I want you to realize the possibilities you have for creating a sensation with this master mystery. My only regret is that I cannot first present this effect before you and let you puzzle over it for a few weeks before I teach you the secrets of it. You would then appreciate that its very simplicity is what makes it so baffling.

A peculiar thing about this effect is the elusive principles on which it is designed. Even after you have learned how to perform it, if you were to see me present it, you might doubt my having given you the correct method. It is so elusive that some of the finest magicians on the stage to whom I have taught the effect have asked me time and again whether I was sure that the methods I taught them were the methods I use myself. I have gone into every detail of the presentation with them over and over to convince them that I had really given them the true secrets.

I have refused hundreds of dollars for these secrets for I desired to disclose them to the profession as a whole. And now you are getting one of the finest effects ever designed in the whole history of magic right in with the rest of your wonderful course. Guard this mystery carefully, for remember that the secret of greatness lies in being able to do something that no one else or but few others can do.

Perform this effect as "A Hindu Miracle," for giving it the Hindu atmosphere permits of fine newspaper publicity and advertising. The fame is widespread of the story of the East

Indian Rope Trick, in which a rope is thrown up into the air and is then climbed by a boy. Associating your effect with this one fires the imagination of the audience and permits of a miracle performance. The Orient has always been known for its mystic splendor and thus presenting an Oriental effect gives you an opportunity for background and stage setting that will add romance to your program.

One big advantage of this rope mystery is its versatility. It is simple and may be carried in the pocket for performance at a moment's notice. And yet it is so designed as to be made a feature number on a program. It may be done under the most difficult conditions, close to your spectators, or it may be performed at a distance with excellent effect. It is suitable for parlor work and club work, and also the stage. It can be worked at the dinner table and has proved to be a sensation at banquets.

There are several methods for performing this rope mystery. This permits you to vary the effect for different occasions. I want you to learn every method. Then you may select the routine you prefer and rehearse it until you can convince any audience that you are performing an oriental miracle.

Do not present this mystery as you would a pocket trick for that will not bring you the power which this effect brings. Stage it in the proper atmosphere so that you will gain all the credit you can from it. Build an interesting story around it and present it in a convincing, positive manner, working up to the forceful climax.

* * * * *

METHOD A

This is my favorite method because it permits you to repeat the effect and then pass out the rope for examination without exchanging it.

EFFECT:

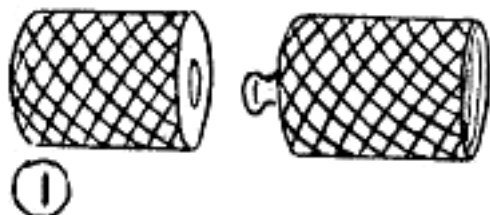
A piece of fairly soft white clothesline, about seven and a half feet long, is freely shown. The two ends are tied together in a knot to form a "mystic Hindu circle." A spectator is given a pair of scissors and is asked to cut the rope in the center opposite the knotted ends. The rope is cut and the cut ends are held far apart. To make sure that the rope has been cut, a piece is cut from each of the two ends. The two cut ends are placed together, part of the rope wrapped around the left hand, and a magic ring applied to the rope. The rope is then removed from left hand and shown to be completely restored again to the mystic circle, as in the beginning. Performer then states that perhaps there are a few in the audience who do not know how the mystery is done. He asks spectator to cut the rope again in the middle and to cut a piece again from one of the ends to make sure the rope is cut. The two ends are then tied together in a knot. Magician now holds rope with knots at opposite ends. He cuts off one of the knots, then passes his hands over the two ends and touches them with magic ring. Suddenly the rope is restored. Performer now unties knot at

(50-2)

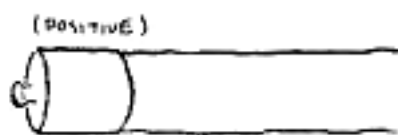
original ends of rope. Two spectators are asked to pull on rope to show it is whole, and then rope is thrown out to audience for examination.

PARAPHERNALIA:

- 1 -- A piece of soft white clothesline about six or seven feet in length.
- 2 -- A piece of similar clothesline about six inches long.
- 3 -- A piece of clothesline about ten inches long.
- 4 -- A metal or wooden ring, an inch or so in diameter.
- 5 -- A pair of scissors, preferably with round ends.
- 6 -- Two Special Rope Gimmicks or Fasteners.

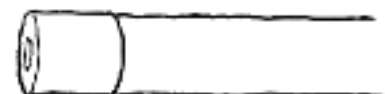


①



(POSITIVE)

②



A Rope Gimmick consists of two pieces of tubing, corrugated and painted white to resemble the rope. One part of the Gimmick has the positive side of a snap fastener and the other has the negative side. Each part is so made as to screw on to the end of a rope. When they are placed on the rope and then fastened together, they are not visible at a short distance, especially if the rope is swung a little. When the rope is held close for inspection, the fingers cover the Gimmick. These Gimmicks may be used over and over again.

Figures 1, 2, and 3.

SECRET AND PATTERN:



③



④

To Prepare:

How to Attach Special Gimmick to Rope -

Take the long piece of rope and the six-inch piece and prepare both ends of each piece as follows: Near the end wrap a piece of white thread tightly around several times.

Figure 4.



⑤

With sharp scissors, cut end of rope up close to thread. Figure 5.



⑥

This gives a substantial enough end on which to screw Gimmick firmly. Cut away any thread which may show on rope outside of Gimmick. Be sure to place a positive part at one end and a negative part of Gimmick at other end of each piece of rope.

Figure 6.

NOTE:

The Rope Mystery, as formerly sold, required the use of snap fasteners sewed on to the rope. The method of working the rope trick was the same but it took time and trouble to sew on the fasteners. The new Special Gimmick eliminates all this. It is easily and quickly

screwed on to the rope and can be used over and over again.

However, for the benefit of those who still want to sew on snap fasteners, I shall explain the procedure. I want you

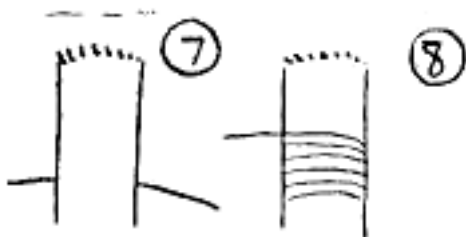
(50-3)

to know how to do this, though I doubt whether any of you will want to go to the trouble, now that the new Gimmick is available.

The fasteners to use are known as ladies' dress fasteners. There are several brands. The one I recommend is the Boye Dress Fastener, Size 3-0.

How to Sew on Snap Fasteners --

The idea is to sew on opposite parts of fasteners at the ends of the ropes so that when they are snapped together, the rope looks whole. It is necessary to use care in not drawing the thread too tight or leaving it too loose. Use white cotton thread, about No. 40, and use a fine enough needle to go through the holes in the fasteners. Use about a yard of thread and double it for each part of fastener.



Take end of rope and pull needle through about half an inch from the end, bringing thread through to knot. Figure 7.

Wrap the thread around rope four or five times and run needle through rope again. Figure 8.



This wrapping of thread keeps small strands of rope from unraveling so that you can cut rope off sharply about a sixteenth of an inch above it.

Figure 9.

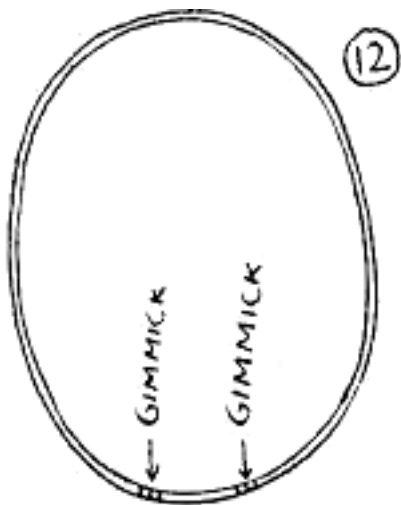
Now take one part of fastener and sew it carefully to end of rope.

Figure 10.

Run needle through rope again, then wind enough thread around rope again to even it up. Run needle through rope several times and cut thread close to rope.

Figure 11.

A little practice will enable you to make a nice clean-cut job of sewing on the fasteners. The more care used and the neater the work, the better results you will get. Paint the nickel fasteners with a little white Japan paint, (it can be purchased in small tubes), which has been thinned with benzine for quick drying. The advantage of using white paint is that less thread can be used in sewing on fasteners and thus the two opposite parts will grip tighter together. As with the Gimmicks, be sure that you have opposite parts of fasteners at each end of each piece of rope.

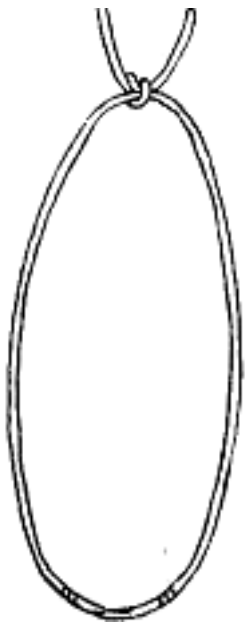


How to Prepare Rope --

Take the long piece and the six-inch piece of rope which you have prepared with Gimmicks or snap fasteners. Attach the short piece to the long one to form a circle of rope.

Figure 12.

Now tie the ten-inch piece of rope around the middle of the rope, opposite to the Gimmicks. This gives the effect that the ends of the rope are tied together where the extra piece of



13

rope is tied on. The real ends of the rope are attached by Gimmicks to the six-inch piece, and as these are invisible, it gives the effect that this is the middle of the rope. The audience knows nothing about the Gimmicks and, of course, is not looking for them. I have never had the Gimmicks detected. Especially if rope is swung a little, Gimmicks are not detectable. Figure 13.

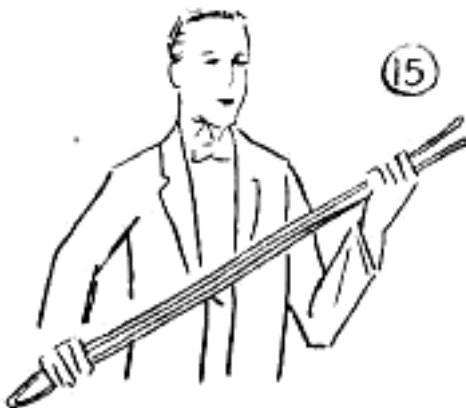
Fold up prepared rope and place in coat pocket or some handy place. Scissors may be in upper left coat pocket. I use the round-end scissors to avoid possibility of accident from sharp points. Place the "magic" ring in right trouser's pocket.



14

To Perform:

Take rope from pocket and open it up. Hold knotted ends up in hands, allowing part with Gimmicks to hang down. Figure 14.



15

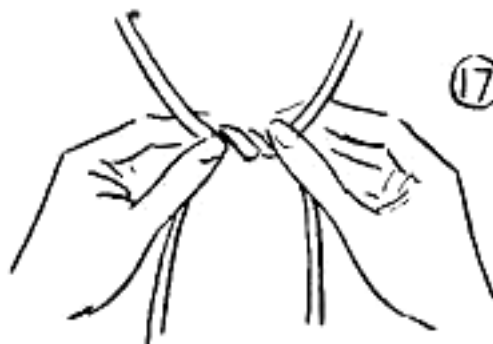
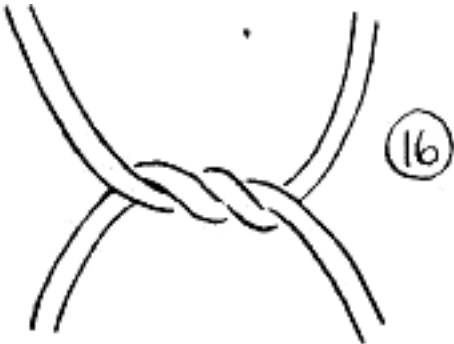
As you talk, untie the knot, and without exposing the short piece of rope, hold long rope between your hands as shown in Figure 15. Right hand covers the Gimmicks and left hand covers joining of long rope with ten-inch piece.

"There is perhaps no magical effect in the world as well known as the great East Indian Rope Trick. You have all heard tell of this trick in which a rope is thrown high into the air and is then climbed by a boy until he gets way up out of sight. There is, however, another rope effect, equally mysterious and, like the East Indian Rope Trick, seldom seen. It is performed by a certain high caste of Hindu magicians. Tourists,

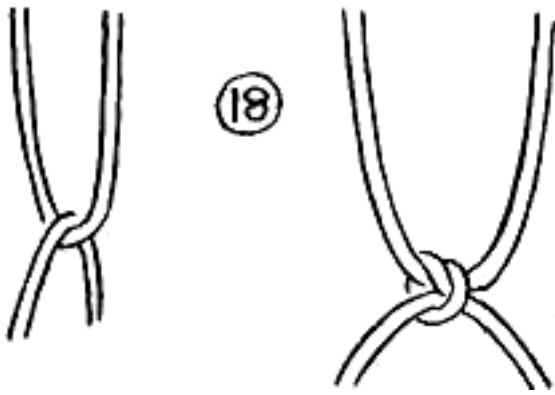
watching this odd mystery, have been completely baffled. Even magicians who have seen it time and again have been able to offer no solution to the problem. Dr. Harlan Tarbell of Chicago, a prominent American Society magician, discovered the secret, and he in turn baffled magicians as well as lay audiences with it. Until recently, Dr. Tarbell was the only white man who understood the true working of this ingenious mystery. Dr. Tarbell very kindly taught me this peculiar effect and now I want you to see this miracle of magic."

Have two gentlemen come up and have one stand at your right and the other at your left.

"The Hindu magician performs out in the open with the sky as the roof of his theater. He uses a piece of rope about this long and ties the ends together to form a circle."



Drop rope from right hand and grasp the short piece of rope at other end, being careful not to expose it as a separate piece. Wrap one end of short piece around big rope once again and bring it upward as shown in Figures 16 and 17. To the audience it appears that you tied a single knot with ends of the rope.



18

19

Now allow this same end of short rope to drop down again and bring it upward so that it is only once around long rope. Drop your hands as you do this and bring them up again to keep audience from detecting what you are doing. Then tie a single knot with two ends of short rope on long rope.

Figures 18 and 19.

To the audience it appears that you tied a double knot with the ends of the long rope.

"His effects are based on Hindu philosophy and occultism. It seems that the circle, the square, and the triangle have mystical occult meanings. The Hindu sometimes sits inside of his circle of rope and calls it his cycle of life."

Place rope down in front of you near the floor to illustrate how the Hindu places his circle on the ground. Then bring rope up again.

"He says that all within is physical."

Put right hand and arm through loop of rope to illustrate.

"And that all without is spiritual or psychic."

Wave right hand outside of loop of rope.

"To pass from the material to the spiritual plane, it is necessary to cut the line of life. In which case, we shall just cut the rope."

To gentleman at right:

"Would you mind, sir, taking these scissors?"

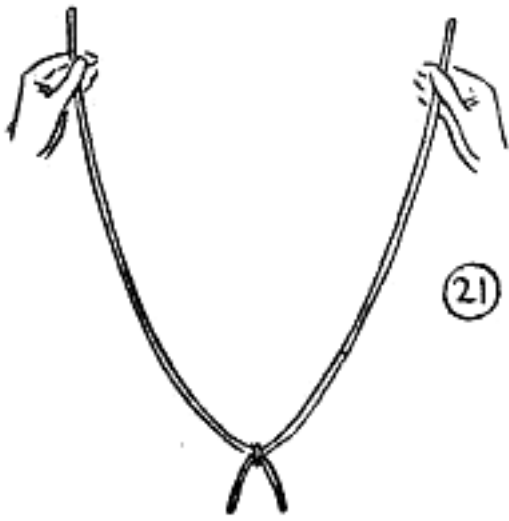
Remove scissors from upper left coat pocket and give to this spectator.

"Now, will you please cut the rope in the middle?"



20

Turn rope around so that Gimmick part is at top between your hands. Keep Gimmicks concealed. Figure 20.



"I think this is about the middle of the rope."

Have spectator cut rope. Audience thinks he is cutting whole rope in half, but in reality he is merely cutting short piece in half between the two Gimmicks. Hold the ends far apart.

Figure 21.

"Thus the Hindu says he can enter the psychic world. Are you quite sure, sir, that you cut the rope? Just to make doubly sure, cut it again. Cut a piece from this end."

(50-6)



22 Hold rope as in Figure 22, and have spectator cut a piece from left side of rope within about an inch of the Gim Mick, keeping Gim Mick concealed. Toss this piece to audience.

"Perhaps you would like a souvenir."

Show cut end to spectator at your left, and say:

"Will you notice the cut end, sir?"

Now to gentleman at right:

"To make positively sure that the rope has been cut, will you kindly cut a piece from this end also?"

Hold rope so that he cuts a few inches from right end of rope rather close to Gim Mick. Give him the piece of rope just cut off.

"Please toss it over there to the lady."



23 You now have an inch-stub of rope attached to each end of the long rope by Gimmicks. While spectator is tossing piece of rope to lady, take ropes in hands as in Figure 23. Grasp the short stubs between thumb and base of first finger of right hand. This view is away from audience.

Figure 23.

SHORT ENDS



With a natural movement, pull the Gimmicks loose from long rope. Back of right hand is to audience. Figure 24.

"I should have a magic ring for this."

Reach into right trouser's pocket and leave the short pieces of rope there, bringing out the ring.



24

"Here it is in my pocket."

To gentleman at left:

"Here, sir, I shall give you the magic ring."



25

Give him ring and then hold ends of rope far apart in your two hands. Be careful to conceal Gimmicks at ends of rope with your fingers.

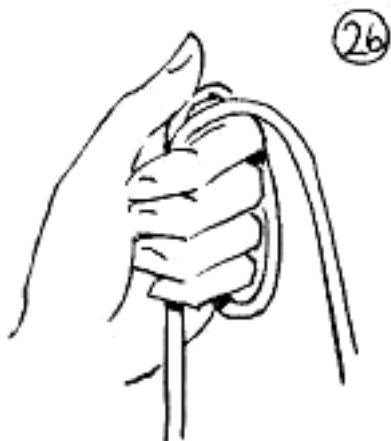
Figure 25.

To gentleman at left:

"I believe you, too, are quite sure that the rope has been cut. No doubt, you wonder why I ask this so many times. I do it because when I get through and you go home, you may wonder whether the rope was really cut. Anyway, the Hindu brings the ends of the rope together for just a second. . . "

Bring the two ends of rope together and under cover of the fingers, snap the Gimmick together. Do this with as little noise as possible.

"And wraps the rope around his hand."



Wrap rope quickly around left hand with the right so that audience cannot see that rope is already restored. Figure 26.

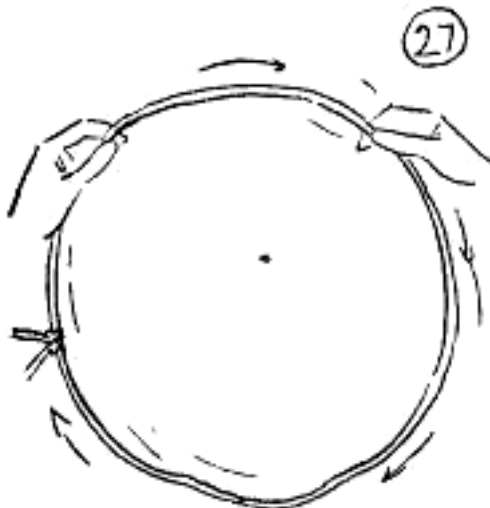
"Touch it with the magic ring, sir."

Gentleman touches rope with ring.

"The Hindu says, 'Chee-la-wah-la-bong-wah. Watch, for you are about to behold a miracle -- a miracle you will never forget as long as you live.' Then he quickly unwraps the rope from his hand."

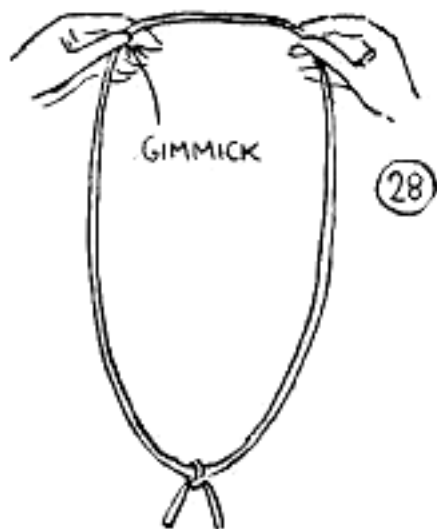
Unwrap rope.

"And, of course, the rope has been restored completely to what it was in the beginning."



Show rope by passing it quickly around in a circle through both of your hands. This gives the form of the magic circle and also keeps Gimmick invisible.

Figure 27.



Finally get rope into position so that knot is at bottom and left fingers cover Gimmick.

Figure 28.

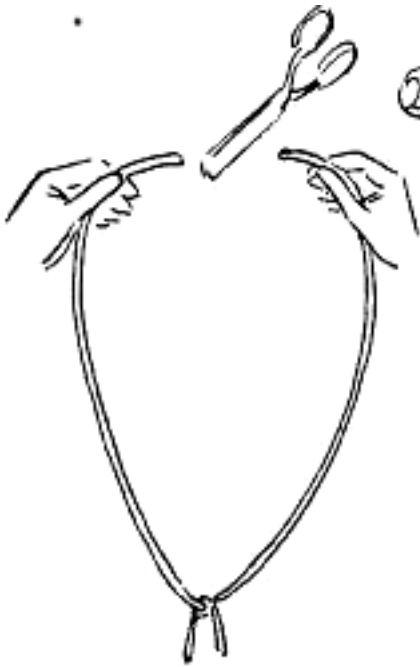
"I realize that it may be hard for several of you to understand how the Hindu restores his life-line, so perhaps I had better explain it to you all over again."

This usually gets a laugh because there is no one in the audience who knows how to do the trick. The tendency in such an effect is for the audience to want to get the rope and examine it. You forestall this until you are ready to pass out the rope by saying you will do the trick again.

In some effects repetition is not good, but in this rope mystery, repetition strengthens the effect and leaves the audience thoroughly mystified. The two methods of working are different so there is no danger of detection.

To gentleman at right:

"Please cut the rope again."



29 Have spectator cut the rope about an inch and a half to two inches to the right of the Gimmick in left hand.

Figure 29.

"And to remove all suspicion, cut the rope again."



30 Grasp left side of rope about four inches below left hand with your right hand and have the rope cut between your two hands. That leaves the long loop of rope entirely free from Gimmicks in your right hand and the short piece of rope with the Gimmick in your left hand.

Figure 30.

Casually place left-hand piece with the Gimmick in your left coat pocket. Do this without hesitation as if you were just getting rid of the cut piece of rope. Audience sees nothing suspicious in this.

Now hold both ends of rope far apart and say to gentleman at left:

"Since you are one of the chief inspectors, perhaps you would like to look at this rope a bit closer. Examine the ends."

Allow spectator to examine the ends of rope closely.

"Since you give your official O. K., I shall now tie the two ends together to form a knot."



31 Tie the two ends together in a double knot. You now have this real knot and the fake knot at opposite ends of the rope. Figure 31.

Take scissors from gentleman at right.

"The Hindu says now his troubles begin because the knots are supposed to be knots of trouble in his life-line. One knot of trouble is enough, he says, for any good Hindu. Of course, we can make the knots less conspicuous by trimming them up a bit."



32 Trim the ends of the knots up to about an inch from each knot. Try to make the knots look alike. Then hold both knots in left hand as you gesture with right. This confuses the two knots so that audience cannot keep track of them separately.

Figure 32.

"Of course, we have two knots."



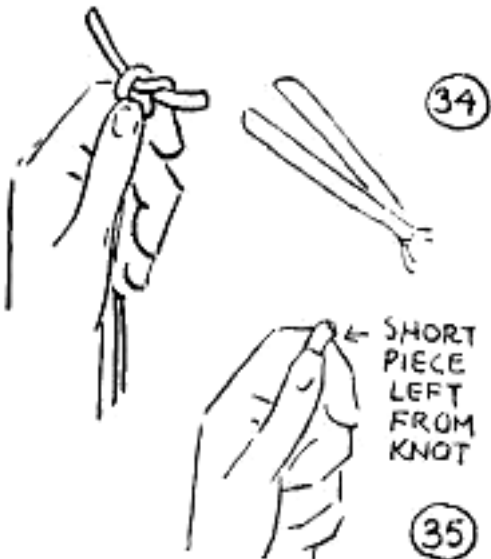
33 Take a knot in each hand -- the fake knot in the right hand and the real knot in the left hand. Show knot in left hand, pretending this is the first knot tied.

Figure 33.

"This one is the one we tied originally to make a mystic circle of the rope."

Then show knot in right hand as the second knot tied.

"And this knot is the one tied from the two ends the gentleman just cut. I believe, sir, you cut the rope."



34 Drop real knot from left hand and bring fake knot in right hand over to left, holding rope from this knot as shown in Figure 34.

With right hand cut knot off, leaving a short piece still around long rope.

Figure 35.

"If a knot causes trouble, the solution to the problem is to cut the knot off. This leaves two ends as we had before we tied the knot. Of course, we can even up the ends."



36 Pull up end of short piece and cut it away, repeating until you have finally cut away the short piece entirely and have the long rope looped in left hand.

Figure 36.

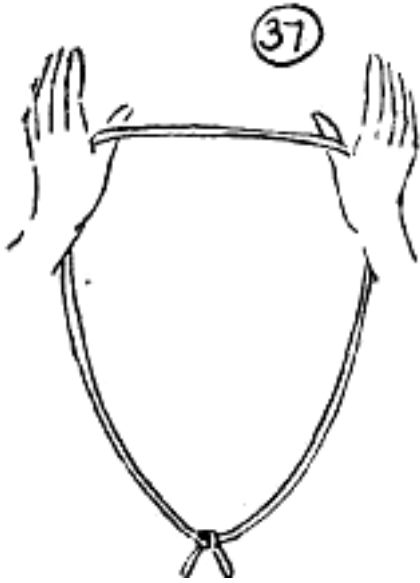
"While the life line is cut, the Hindu says he projects his astral body back into the physical again. He wraps the rope around his hand again."

Wrap rope around left hand several times. Then ask spectator who holds ring to touch rope with it.

"Touch it with the magic ring. The Hindu says, 'Chee-la-wah-la-bong-wah. Watch, and you shall behold a miracle. Hoy!' "

Throw hands upward, releasing rope from left hand.

"And the rope is again restored."



Hold rope over your thumbs. Turn palms of hands to audience and spread fingers wide apart. This exhibits the rope well to audience.

Figure 37.

"To prove to you that the rope has really been restored, I shall untie the knot, and give one end of the rope to the gentleman here and the other end to the gentleman at the other side."

As you say this, untie knot and give one end of rope to spectator at right and other end to spectator at left. Ask them to pull hard on rope, then take it from them.

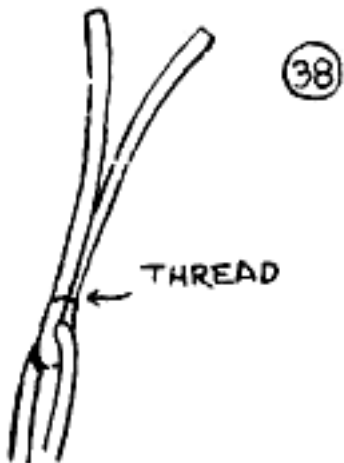
"Thank you. You have pulled hard on the rope and have proved that every fiber even unto the thousandth has been fully restored."

Fold rope up a little in your hand to make it easier to throw.

"Now you can prove it to yourselves by examining the rope."

TOSS THE ROPE OUT INTO THE AUDIENCE FOR EXAMINATION.

This is your finish. Make it as dramatic as possible. Toss the rope high enough to suit the dramatic action. Bow a little. Thank the spectators who assisted you and allow them to go to their seats.



NOTE:

Short piece of rope may be attached in another handy manner. Put it around long rope, then wind a piece of white thread twice around it. This enables you to carry rope prepared in pocket without knotting it in advance. You can also lay rope over your shoulder or over back of chair before it is knotted. The thread is then broken when you tie the knot.

Figure 38.

STUDY EVERY MOVE IN THIS MASTER EFFECT UNTIL YOU CAN PERFORM IT SO THAT AUDIENCES WILL TALK ABOUT AND REMEMBER YOU FOR MANY MONTHS.

As I have said, this is my favorite manner of presentation which is adapted to your use. There are a number of variations which you can use from time to time. These follow.

* * * * *

METHOD B

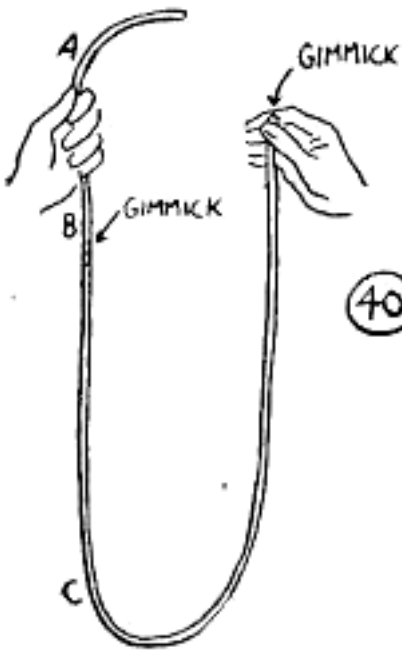
In this method, you start with a straight piece of rope, apparently, without having the rope knotted.



39

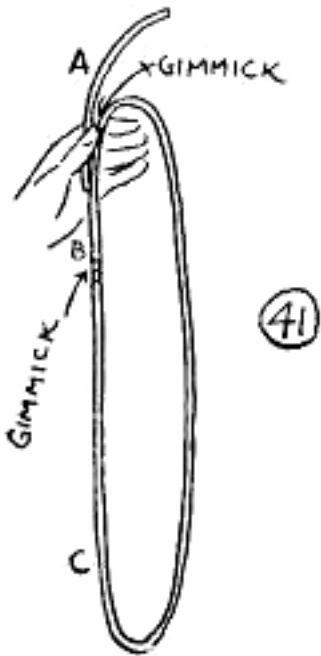
Let A represent the short piece to be tied into a knot--B, the small piece with Gimmicks, which is to be cut--and C, the long piece with Gimmicks. To begin experiment, bring in rope, holding A and B between thumb and fingers of left hand. Back of hand is to audience and they believe you hold one long rope.

Figure 39.



40

Bring up lower end of C with right hand, covering Gimmick. Figure 40.



41

Place this end in left hand, and as you do so, snap Gimmick into top end of B, making a loop of rope.

Figure 41.



42

With right hand, grasp lower end of loop and bring it up to left hand toward short piece A.

Figure 42.



With a swing of the hands, grasp free end of A with right fingers and slip loop of rope in right hand over it. Quickly drop rope from left hand and grasp A so that rope hangs down from A as shown in Figure 43. To audience it appears that you have merely tied a single knot with the ends of the rope.



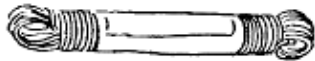
Now tie A once around rope. Audience believes you have now tied a double knot with ends of rope, but in reality, you have the fake knot at one end and the Gimmicks at the other end of the loop of rope.

Figure 44.

These moves all blend into each other as one continuous movement and the audience does not suspect any trickery. From this point, continue with Method A.

(50-12)

THIS IS ONE OF THE FINEST OF THE ROPE TRICK METHODS. In performing, you bring in an apparently unprepared roll of clothesline.



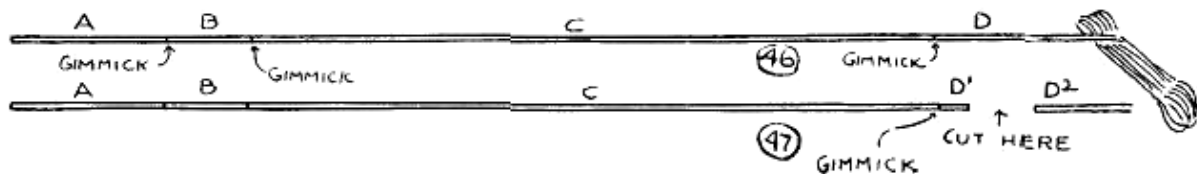
45

Take either a ball of clothesline or the regular roll in which it is sold.

Figure 45.

Unroll the clothesline and straighten it out. Allowing about ten inches for A, about six inches for B, and six or seven feet for C, attach a Gimmick to the ends of A and B--B and C --C and D.

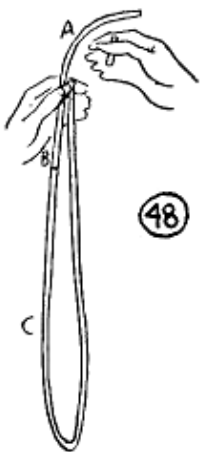
Figure 46.



Roll clothesline back into original form, even to placing a piece of paper around it as shown in Figure 45.

To perform, unwrap the roll of clothesline and unroll it to two or three feet beyond the last Gimmick. Pick up scissors and cut rope an inch or so beyond Gimmick on D.

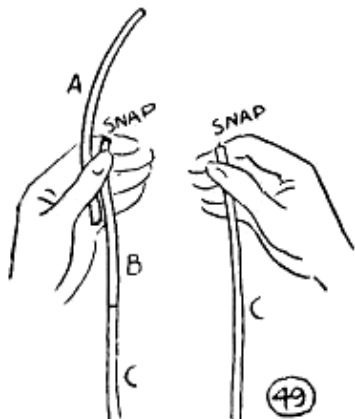
Figure 47.



48

Place roll of clothesline aside and show piece you have cut off. Bring the two ends together in left hand. Backs of hands are to audience. Steal off little piece of D from the Gimmick and pocket it.

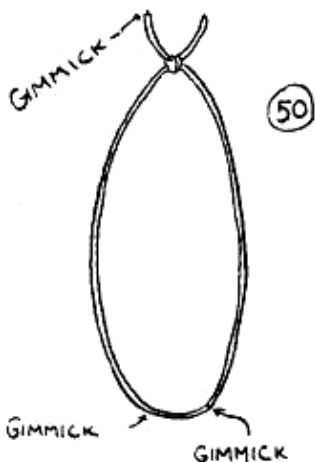
Figure 48.



49

Bring right hand up to left again and pull Gimmick apart between A and B. Now hold A and B in left hand and end of C in right hand. Separate hands a little.

Figure 49.



50

Use routine of Method B to get A tied around long rope and then continue effect by Method A.

Figure 50.

To dispose of Gimmick at end of A, just cut the ends of the knot shorter and put the pieces in your pocket.

* * * * *

METHOD D

EFFECT:

Magician shows a piece of white sash cord about seven and one-half feet long. A spectator is asked to cut the rope in half and the rope is then shown in two pieces. To convince the audience that the rope is actually cut, another spectator is asked to cut a small piece from each of the four ends. Magician then holds an end of each half of the rope and gives the other ends to each of the two spectators to hold. Performer now wraps his two ends of the rope around his left hand. He removes a ring from his pocket and asks spectator at right to thread it on the rope. The ring slides down to his left hand. Suddenly he unwraps the rope and it is seen to be completely restored. The ring is then allowed to slide off other end of rope.

PARAPHERNALIA:

- 1 -- Two pieces of soft white clothesline, each about three and a half feet in length.
- 2 -- A short piece of clothesline, six inches long.
- 3 -- Two Gimmicks.
- 4 -- Pair of scissors.
- 5 -- A metal or wooden ring, an inch or more in diameter.

SECRET AND PATTERN:

To Prepare:

Half of a Gimmick is placed on one end of each long piece of rope. Half Gimmicks are placed on both ends of the short piece of rope. The Gimmicks must be so arranged as to permit you to fasten the short piece between the long pieces of rope and then to remove the short piece and fasten the two long pieces together. Place the short piece between the two long pieces. To audience it appears that you have one long rope.

Figure 51.



By keeping the rope in motion while performing, the Gimmicks will not be visible.

Place folded rope in right coat pocket, scissors in upper left coat pocket, and ring in right trousers' pocket.

To Perform:

Have two spectators come up to assist you. Place one of them at your right and a little in front of you and the other one in a similar position on your left. For convenience in explaining, let the man at the right be Smith and the one at the left, Jones.

"All of you, no doubt, have heard of the great East Indian Rope Mystery, in which a rope is thrown high into the air where it

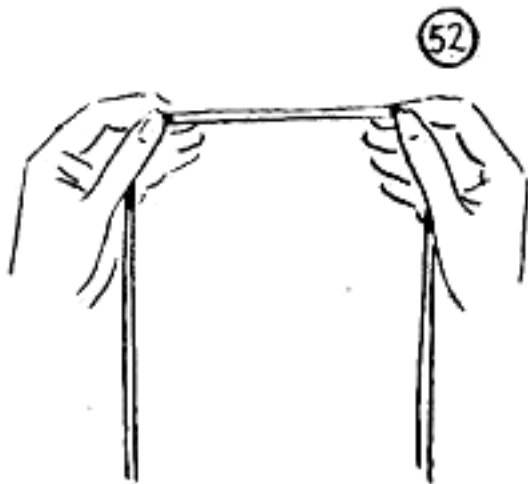
remains suspended so that a boy can climb it and vanish into space. Thousands have told about this mystery, but no one except a very few magicians have been able to solve it. Would either of you two gentlemen like to climb up a rope? Well, perhaps, it will not be necessary. India is famous for its rope tricks--and there is another rope mystery which has not only baffled tourists in India, but has baffled every magician who has ever seen it. A few years ago Dr. Harlan Tarbell of Chicago, an eminent American magician, discovered the secret. He first presented the effect in Paris with great success. Only until recently he was perhaps the only white man who understood the working of this peculiar rope mystery. Dr Tarbell very kindly taught me how to present this ingenious mystery, and I want you now to see this miracle of magic. The Hindu usually performs out in the open with the sky as the top of his theater. To begin his rope miracle, he takes a piece of rope from his pocket similar to this one."

Remove rope from pocket and unfold it, keeping it slightly in motion.

"A rather short piece of clothesline, but long enough for a Hindu washing."

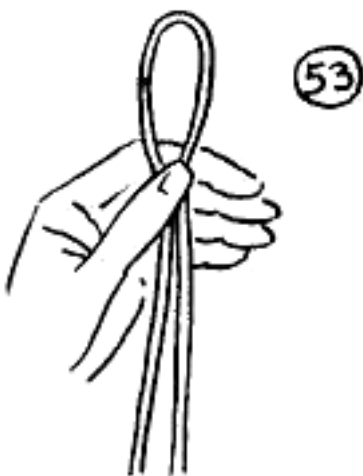
Start with left end of rope and run it through your hands. Give rope three or four tugs in different places, being careful to pull rope only outside of middle piece. This convinces audience that rope is strong and is in one piece.

"Strange to say, the rope has two ends and a middle. The middle should be about here in the center."



Run rope through your fingers until you hold a Gimmick between thumb and fingers of each hand.

Figure 52.



Bring two Gimmicks together and hold in left hand while you bring out scissors with right hand.

Figure 53.

To Jones, at left:

"Please take these scissors and cut the rope in two pieces of about equal length."



Give him the scissors, then hold rope as shown in Figure 52, and have Jones cut rope between the two Gimmicks. Audience believes he is cutting the rope in half, but he is merely cutting the short middle piece between the two Gimmicks. Separate your hands about two feet so that all can see the separate pieces of rope.

Figure 54.

(50-15)

"Are you sure you cut the rope? Would you mind just cutting a piece off an end here for a souvenir?"

Have Jones cut about an inch from the short piece in your right hand.

"Now cut a piece from the other end here."

Jones cuts a piece from the short rope in your left hand.

"Please examine the two ends. Give the scissors to the gentleman here and let him cut off the other two ends."

Bring lower ends up and have Smith cut about an inch from each. As he does this, let him hold the two lower ends, while you retain your hold on the two upper ends in your left hand.

Bring your right hand up to left and palm off the two short pieces from Gimmicks on ends of long ropes. Carry these away between thumb and base of first finger.

When two ends are cut and examined by Smith, reach into right trousers' pocket. Leave the two stubs of rope there and bring out the ring.

"This is a Magic Hindu Ring. Will you, Mr. Smith, look at it closely?"

Hold both ropes apart in your hands, keeping Gimmicks at top covered by fingers.

"By the way, are you sure that you cut the rope in half? I want you to be sure so that afterwards you will not say, 'Well, maybe the rope wasn't cut.' Mr. Smith, will you hold one end, and Mr. Jones, you the other? Now, the Hindu ties these two ends together into a knot."



Bring your two hands together and snap the two ropes together by the Gimmick. Do this noiselessly and under cover of your hands. Keep Gimmick in left hand and wrap rope several times around this hand. This prevents any accidental opening of Gimmick.

Figure 55 shows your position now in relation to spectators assisting you.

"Mr. Smith, will you please slip the ring on to the rope and let it slide down to my hand?"



As he does this, take hold of his end of rope with your right hand and have him release it.

Figure 56.

"It is impossible for the ring to go farther because of my hand. But watch closely, for you are about to see a HINDU MIRACLE. Behold!"

Allow the rope to unwrap from left hand. The rope then straightens out between your right hand and left-hand spectator, and ring slides down to left end of rope.

"The rope becomes whole again!"

Take rope from Jones and allow ring to slide off into your left hand. Place ring in pocket.

Run rope through your hands, keeping it in motion so that Gimmicks will not be detected by assistants. Pull on rope several times to show it is whole, keeping on each side of the Gimmick. Dismiss gentlemen assisting you.

* * * * *

METHOD E

This method is extremely puzzling for it seems that the spectators do the work themselves and allow no opportunity for trickery.

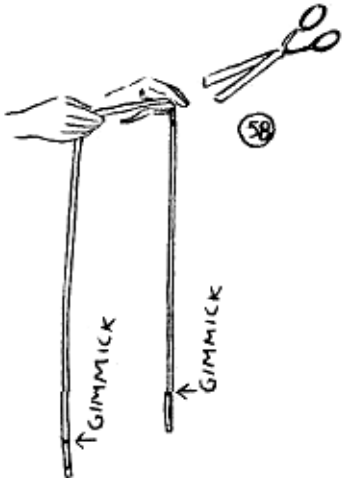
Take a piece of clothesline about seven feet long, and two small pieces about three inches long. Screw a half-Gimmick on each end of the long rope and corresponding half-Gimmicks on one end of each short piece. Fasten the three pieces together.

Figure 57.



Place rope in hands of spectator at left. As the Gimmicks are near ends of rope, they hang down and are not noticed. Have this spectator walk over to spectator at right so that latter can cut the rope in half.

Figure 58.

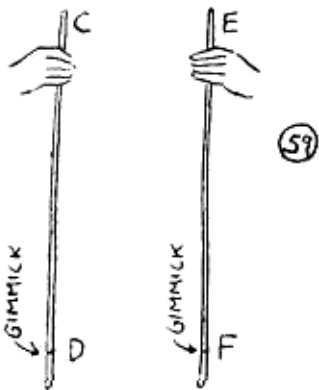


As spectator holds the halves of rope apart, you grasp ropes at D and F with your left hand, covering the Gimmicks.

Figure 59.

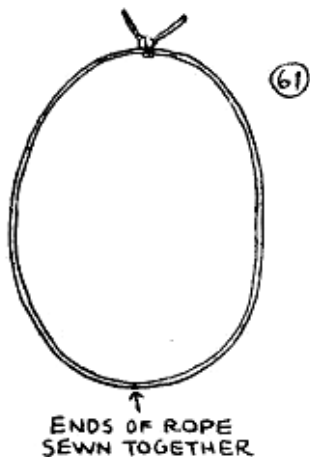
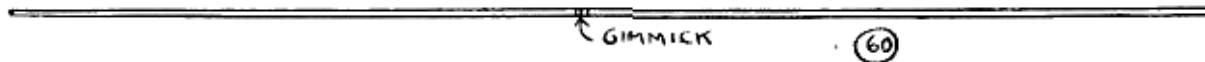
Ask spectator to drop rope. This brings ends D and F upright in your hand. Cut pieces from D and F so that inch-stubs remain above the Gimmicks. Then give scissors to gentleman at left and have him cut pieces from ends C and E. As he does this, steal the short stubs of rope with right hand. Reach into pocket for magic ring and leave stubs there.

Continue routine as in Method D.



The rope is, of course, restored by snapping the two remaining halves of the Gimmicks together.

Figure 60.



* * * * *

METHOD F

This is a very simple method, requiring no Gimmicks.

The effect is that a piece of rope is tied together to form a loop. It is then cut in the middle, opposite to the knot. Several inches are then cut from one of the cut ends. These ends are then tied together. Magician now cuts away one of the knots and the rope is restored.

Take a length of rope and sew the two ends together with white thread. In the middle of rope, opposite to sewed ends, tie a small piece of rope to make a fake knot.

Bring rope out prepared as shown in Figure 61.

Follow routine of second part of Method A to perform this effect.

* * * * *

There you have the real secrets of the **TARBELL ROPE MYSTERY**. You will find any one of the methods a real hit on your program.

It is well to have a number of Gimmicks on hand for emergency. By having this new Gimmick which just screws on to the rope, it makes the rope trick so easy to do. Women, as a rule, dislike sewing on snap fasteners. Another advantage is that with the new Gimmick you can prepare your own ropes and keep the method of performing a secret even from your own family.

Harlan Tarbell

TARBELL SYSTEM, INCORPORATED, Chicago.

* * * * *

Additional paraphernalia described in this lesson for replacement, etc., can be obtained from the Tarbell System at the following prices, postage prepaid. Rope Trick \$6.00

Gimmicks - set 1.00

Gimmicks - 6 5.00

Rope - 100 feet 1.50

LESSON 51

INTERESTING ILLUSIONS. This lesson deals with effects especially adapted to stage work and will prove most valuable to you.

LESSON 51

ILLUSIONS

Every magical effect is really an illusion, but in the magic profession we designate as illusions only the bigger effects in which people are produced, vanished, transformed, or levitated in a mysterious manner.

You have learned a vast number of effects and experiments in the past fifty lessons, and now in the remaining lessons you will learn big illusions.

In presenting illusions to you, I have encountered the problem of selecting only those which are practical for you to perform. I want to teach you those illusions which you can easily build yourself or which you can have built without difficulty.

There are many illusions that I could explain to you, but you would not be able to use them. They are adapted to the uses of the big stage illusionists who work on elaborate principles. They require the expenditure of thousands of dollars on equipment; they require big stage settings and many assistants; they require facilities and expenses for transporting them from place to place.

This course has not been written merely to satisfy the curious, but to provide a system of instruction and training to make you a successful magician. It would be contrary to the purpose of this course, then, merely to give explanations of illusions which you could not use. Take Thurston's Levitation, for instance. Very few, indeed, could afford the thousands of dollars necessary to build it, nor would they have the facilities for presenting it. Therefore, such illusions are not practical for you.

Aside from this, the question of ethics arises. Magicians the world over have entrusted me with the innermost secrets of many of their pet illusions, and I would not think of breaking faith with them. An illusion which a magician has built up as a big feature number associated with himself is really his personal property and I would not feel at liberty to give you his property. You can readily put yourself in the same situation and see what it would mean to you to have your feature numbers put into the hands of others.

There is no need for taking the feature numbers of other magicians, however, for there is plenty of material otherwise to make you a tremendous success as an illusionist. In the following lessons you will find this material, and all you need to do is apply yourself earnestly to learning the principles, to elaborating and adapting the illusions to yourself, and you will have a repertoire that is sure to bring success.

SIMPLICITY IS THE WATCHWORD

I learned a great deal about illusions at an early age. I had little money to do with when I was a boy, yet I insisted on giving magic shows. I had to create my own illusions with just a few common articles and some boards, wielding the hammer and saw to good advantage. Therefore, what illusions I performed meant a great deal of contriving both with my brain and my hands. Now as I look back, I realize that some of the finest illusions I have ever performed have been based on the simple illusions of those bygone days. Through my years of study and work in magic I have continued to keep this watchword of simplicity always before me. And it is with that in mind that I present illusions to you.

The beginner usually wants to have a great deal of apparatus, while the professional is constantly trying to eliminate as much as possible. It costs money to buy apparatus and to set up, take down, and ship heavy material. If one isn't careful, the cost of transportation eats up profits. Many a magician has started out with several trunks and has finished the season with almost a vest-pocket show. This shows you how the professional determines just what is actually required to get his effect and then proceeds to get that effect with the simplest means possible.

THE LAW OF GROWTH

True success is built on the law of growth, starting with little and through accumulation adding day by day to a solid foundation until the goal is reached. Too many people do not understand this. They want to start at the top with a big splash and soon they find that they cannot keep up because of the lack of a solid foundation. Almost invariably, they sink into oblivion.

To follow the law of growth, you must understand values. If you have not already learned this, it is well for you to start right now. Watch every penny to see that you get from it its full value and study the channels you send it into to see whether you get something substantial and something adapted to your needs in return.

To understand the law of growth better, take this example: Give one man a dollar and he sends it into the wrong channels. His lack of appreciation of values results in his having nothing in short order. Give another man a dollar and he soon has two dollars, then four dollars, eight dollars, and so on. The second man knows values and knows the channels to send his money into.

I could tell you some interesting experiences I have had in getting people on their feet financially. These experiences prove that it isn't a case of how much money you have to start with but what you can do with it. With a very few dollars to work with, one of the boys became a big-time number in a period of a year and his bookings extend two years ahead. Another on whom I spent considerable money but who insisted on following his own poor judgment, is now head over heels in debt and has only piece-meal bookings in cheaper theaters. Thus you can see the importance of understanding values and the law of growth.

Thus in giving you illusions I have aimed at simplicity so that you will have a solid foundation to build on. I have selected the practical, the usable effects. Here you have a basis to which to apply the law of growth which will lead you to ultimate success.

* * * * *

THE MYSTERY OF KING TUT

This is an illusion of a comedy nature. It is easy to perform and inexpensive to produce, yet has proved to be a real success.

EFFECT:

Performer says he will give an imitation of the mummy of King Tut and starts to wrap himself in a blanket. His assistant protests, saying that a mummy is not wrapped that way. Thereupon the assistant takes the blanket and wraps himself in it. Performer and assistant argue about the way a mummy looks. Finally, an old gentleman down in the audience joins in the discussion and comes up on the stage. At the psychological moment, the old man removes his wig and beard and shows himself to be the assistant who a moment ago wrapped himself in the blanket. Then the blanket is unwound and a girl steps forth.

PARAPHERNALIA:

1 -- A fairly large blanket. The more color in it, the better—a patterned Navajo blanket does very well.



2 -- A tin or cardboard crown—you can make this or have it made easily.

Figure 1.

3 -- Wig and false whiskers, cane and eyeglasses, loose clothes for assistant to represent old man.

Assistants Required: One man and one girl.

SECRET AND PATTERN:

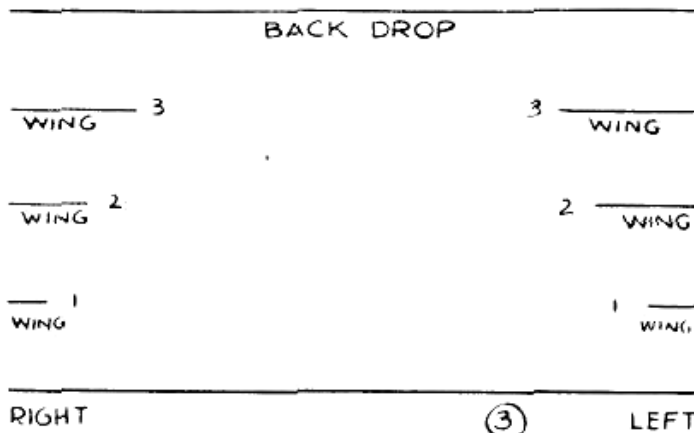
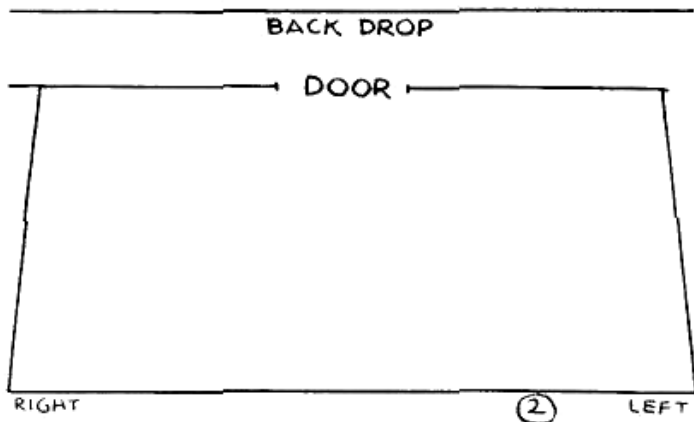
To Prepare:

This illusion is best presented on a stage, but it is also good for parlor use, providing there is a door well placed to make a get-away.

In performing on a stage, the arrangement must be taken into consideration to determine whether it is best for assistants to change places by means of a door at center back or by a side door or by the wings.

Figure 2 shows a stage arrangement with open door at center back.

Figure 3 shows a stage set with wings.



First, I shall explain the method of working when the center door is used. In stage directions right and left are given as the performer faces audience.

Place a chair at rear of stage with crown on the seat. Blanket may be hung over back of chair or in some other convenient place.

The old man's wig, beard, cane, and clothes are offstage at the right so that man assistant can don them quickly at the proper moment.

To Perform.

Pick up the blanket and come forward to center of stage. Have man assistant at your left. Girl assistant stands behind the scenes just to right of door.

"The Mystery of King Tut. With this blanket, I shall imitate a mummy."

Start to wrap yourself in blanket. Assistant comes forward a little and says:

"Pardon me, but a mummy is wrapped in a different manner. You have to whirl into it."

You say in an amused manner:

"Who ever heard of a mummy whirling into a blanket?"

Assistant retorts:

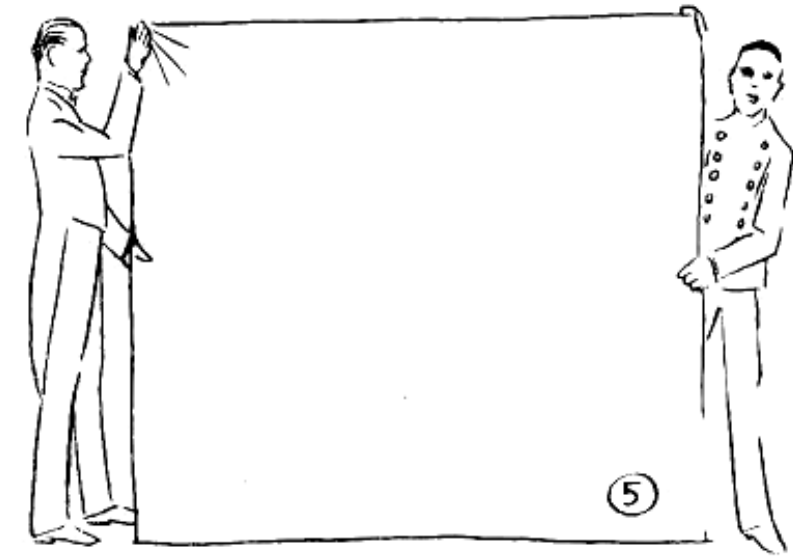
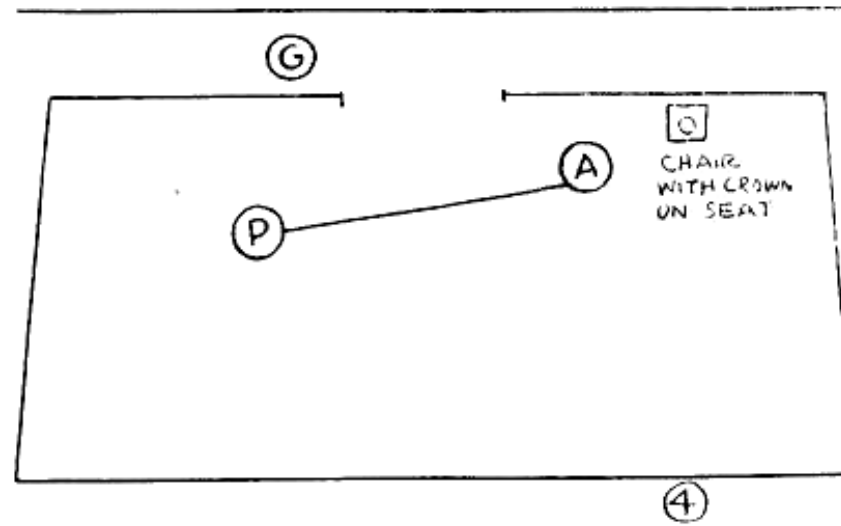
"Anyway, that is how it is done. Dp you mind my showing you?"

You tell assistant to go ahead and he takes blanket. He says:

"Stand there and hold the blanket up high while I hold up this other side."

Figure 4 shows arrangement. P is the performer, A is the assistant and the line between represents the blanket.

Figure 5 shows how blanket is stretched out between you and assistant.



When blanket is held up this way, it screens center door enough to allow a person to enter or exit unobserved.

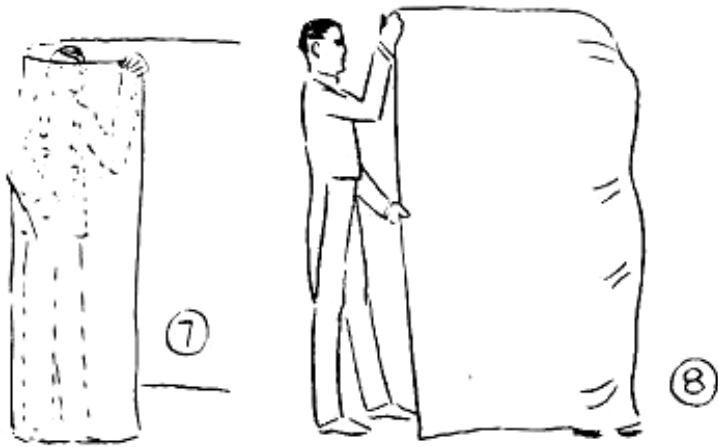
Assistant now says:

"When I roll up in the mummy case or blanket, tuck your end around me. All ready."

Assistant wraps himself in the blanket in this way: He steps behind blanket so that only his left hand is visible at upper corner of blanket.

Figure 6 is view from rear.





He turns to the left, bringing the blanket around him.

Figure 7.

Then he continues turning to the left until he is completely wrapped in the blanket.

Figure 8 is view from audience, while assistant is wrapping himself.



When he is wrapped as in Figure 9, he motions to you under blanket and calls to you to undo him.

"Unwrap me quick. Let me out."

Hold corners of blanket firmly while assistant unwraps himself by turning to the right several times. When he is unwrapped, you say:

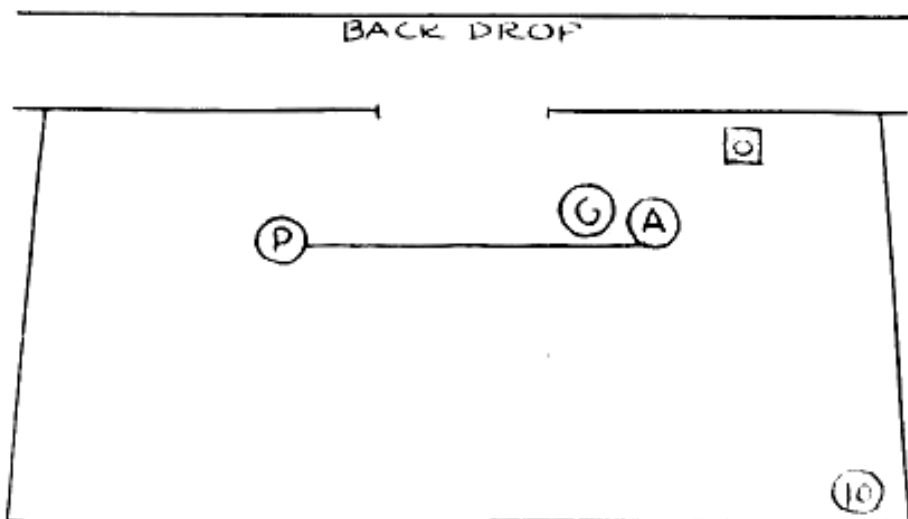
"What is the matter?"

He tells you that he forgot his crown. He goes over to chair, picks up crown, and shows it. Then he says:

"When I get wrapped up as a mummy, put the crown on my head. This is a king mummy and must wear a crown."

He replaces crown on seat of chair and picks up ends of blanket again as in Figure 5, saying, "All ready?"

This is the cue for girl assistant to come through center door and step behind blanket. She will not be seen by audience if blanket is held properly. Relative positions of Performer, Assistant, and Girl are shown in Figure 10.



Assistant then steps behind blanket as he did the first time.

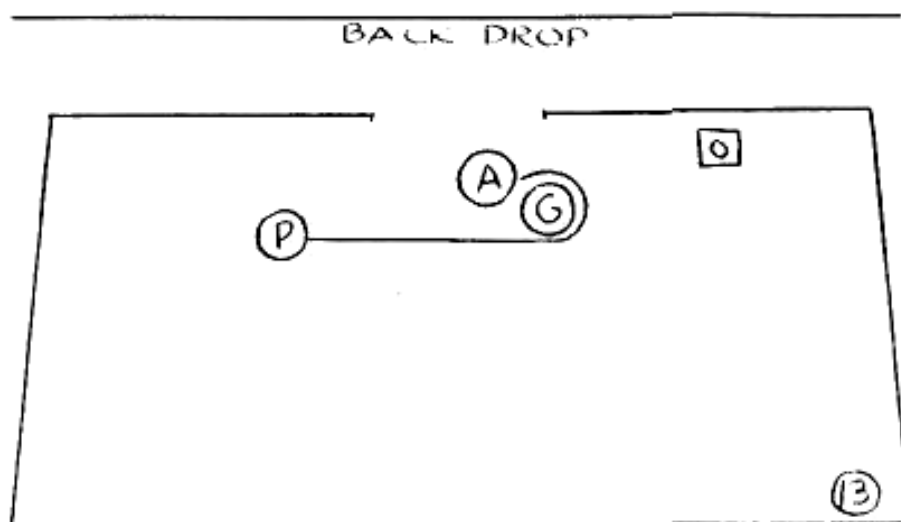
Figure 11 shows position of assistant and girl from rear.

Now comes a move which must be studied carefully in order to make it natural. When assistant wrapped himself, his right elbow naturally protruded from under the blanket. As girl is wrapped, she must imitate this elbow movement.

Assistant steps behind and to right of girl while she slips into his place. As assistant brings blanket around her, she turns around, pushes right elbow out a little into blanket, and grasps upper corner of blanket with left hand. This is done quickly in one continuous movement so that audience suspects nothing.

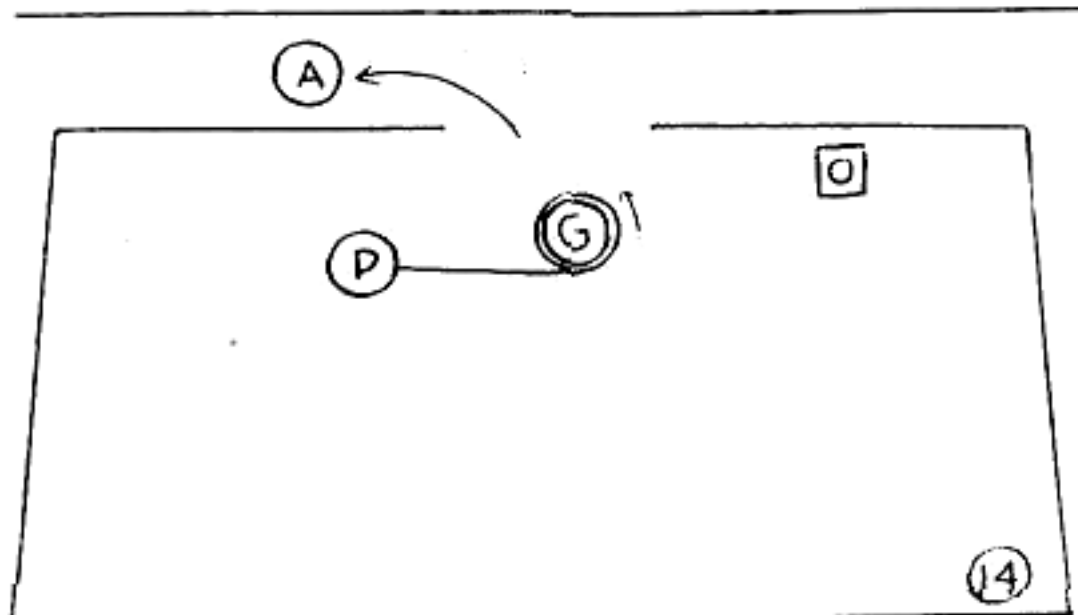
Figure 12 shows the actual movement.

Figure 13 shows a diagram of the positions at this point.



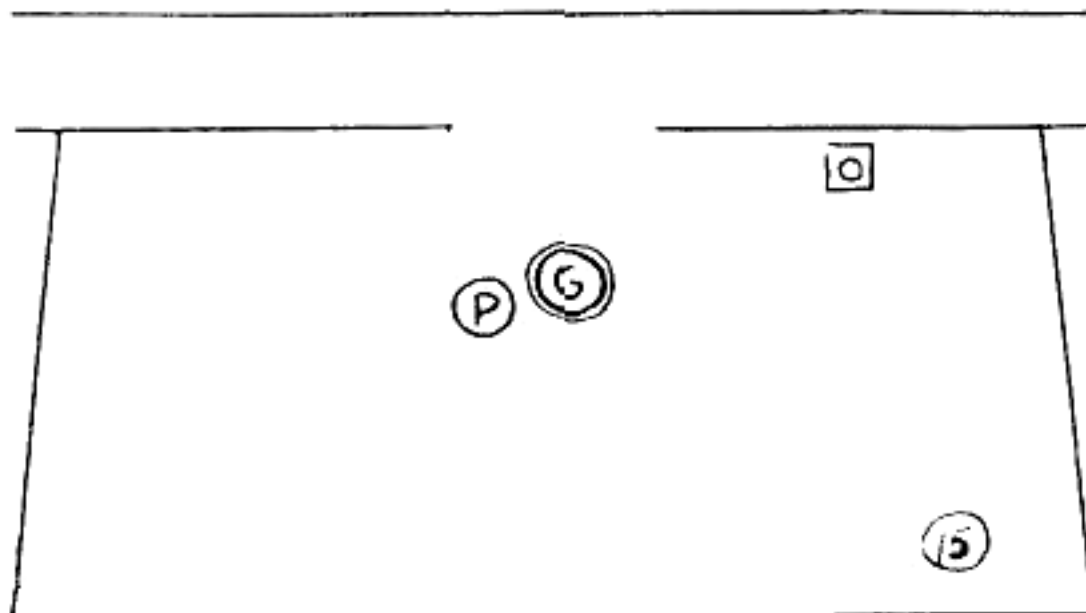
Assistant now quickly exits through center door and back stage and puts on the old man's clothes, the wig, whiskers, and eyeglasses as hurriedly as possible. The moment assistant is offstage, girl continues to wrap herself in blanket by turning to the left just as assistant did the first time.

Figure 14.



When girl is wrapped as in Figure 9, she moves her arms under blanket and turns her head and shoulders toward crown. This gives a funny effect.

Figure 15 shows a diagram of position of girl and yourself at this point.



You walk over to chair and pick up crown. Bring it over and place it on girl's head over the blanket.

Figure 16.

"I never saw a mummy with a crown-not even a king mummy like King Tut."

The patter from now on must be worked up to the proper length to allow assistant to get into his clothes and to come around to rear of theater or hall so that he can come up the aisle from back of the audience. If desired, you may give him time to sit for a moment in an empty seat.

(b) Assistant must hurry as much as possible as speed is important in working an illusion. While he is taking the necessary time, you must keep up the interest of the audience. You talk and the girl answers with motions, bending her body and shaking her head.

"The crown was placed in a separate compartment outside of the mummy case, if I remember right."

Girl shakes head from side to side to indicate, No.

"I do not know where you saw mummies or where you studied their getup. I still doubt whether you are even wrapped right."

Girl shakes head for Yes.

"Turn around once and let us see your back."

Girl turns back to audience.

"You are a fine looking mummy. If King Tut looked like that, he must have had an ignorant mummy wrapper and crown placer."

Girl turns to face audience again. Then you say to spectators:

"Do any of you people know anything about how a mummy was wrapped?"

Assistant dressed as old man hobbles up the aisle and talks in squeaky voice.

Figure 17.

"Hold on, young feller. I know how mummies is wrapped. I've wrapped and unwrapped many of 'em in my day. He ain't right and you ain't right. Neither one of you has the right idea. Egyptian mummies is peculiar things."

He comes down to stage and points cane at performer as he talks.

"Gol ding! The mummy clothes is crooked. Let me show ye how to fix 'em."

You say:

"Come up on the stage, dad."

You assist him up and this is another chance for comedy.

Assistant says:

"Gol ding! Take off that there crown. Unwrap the young feller and let's commence right. I'll show ye how Cleopatra herself was wrapped up."

Remove crown and unwind blanket by holding outer corners while girl revolves to the right. When she is free of blanket, it drops to floor and is held only at one end by performer. When girl appears, old man says:

"Gol ding! He's a girl."

Then he quickly removes spectacles, beard, and wig and shows that he is the man assistant who is supposed to have been wrapped in blanket.

Figure 17A.

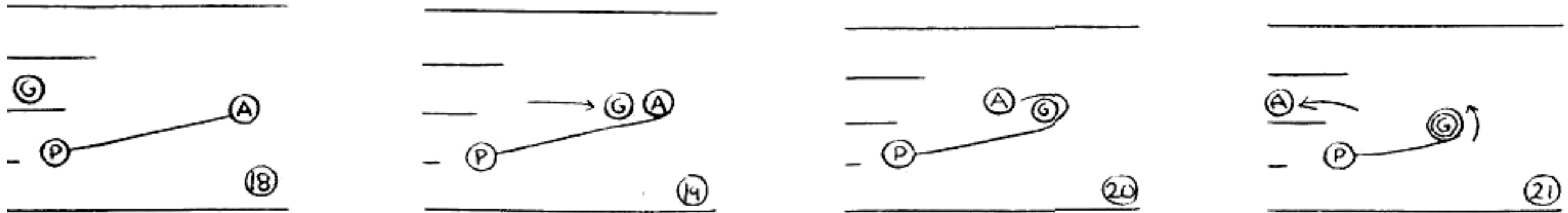
(51-8)



You should have no trouble with this excellent illusion if you study the details of it and use care in performing. Notice the effect when assistant wraps himself in blanket and have girl imitate the movements to produce the same effect. Try to cover the feet as much as possible, but to avoid detection in case they are exposed, have the girl's and man's shoes similar. The costume of the girl may vary. It may be Turkish, Chinese, or any straight costume desired. If it is Chinese, the trousers and shoes of girl and man can be very much alike.

To Perform King Tut Illusion with Side Wings of Stage--

With this stage arrangement, have girl stand back of second wing at right of stage. When assistant and you hold blanket up, stand in such position as to screen edge of wing enough for girl to get behind blanket and for man to exit. Study Figures 18, 19, 20, and 21 for the various positions in performing illusion.



* * * * *

WHO AND WHICH

This illusion may be staged simply or very elaborately. It permits of many variations and I shall discuss methods to meet various needs.

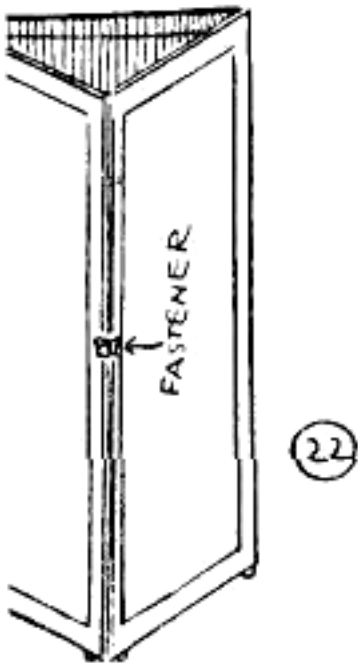
EFFECTS:

Performer dresses as a Hindu. He puts his girl assistant in a cloth sack and ties the opening together above her head. He places a three-sided parlor screen around her. Going through some oriental ceremonies, he walks around the screen and finally opens it. The bag is still there with the figure inside of it, but when the Hindu opens the bag, performer steps out of it instead of the girl who was placed there. The Hindu, who a moment ago was the performer, removes turban and whiskers and proves to be the girl assistant.

PARAPHERNALIA:

1 -- Two Hindu costumes made alike. Each consists of a turban, false beard with mustaches attached, a Hindu coat which reaches to the floor. The sash around coat is sewed on and opens in front with opening of coat. This speeds matters in dressing and undressing.

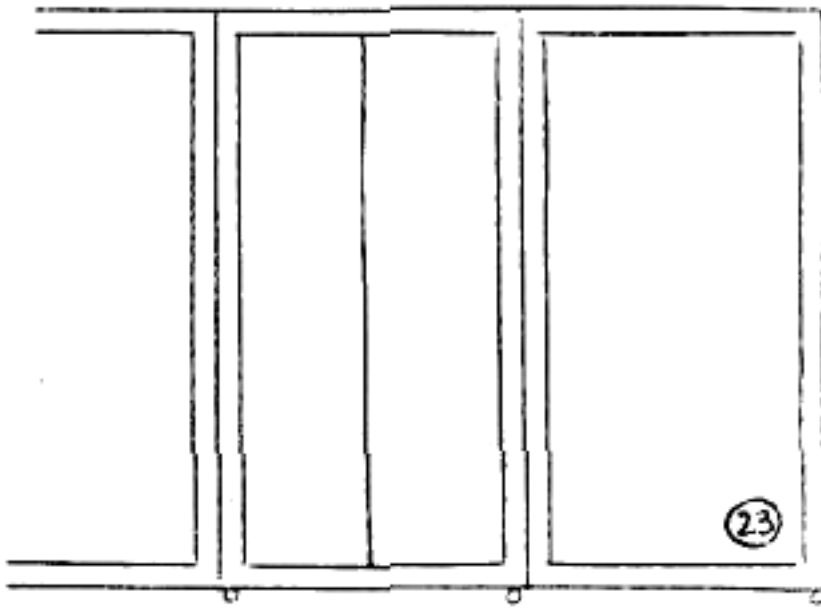
2 -- A special three-sided screen.



Any good carpenter can build this for you, following directions given here.

Make three wooden frames for three sides of screen. Hinge middle section to the two sides. Set screen up in a triangle and place a fastener on the two sides. Screen may be mounted on casters so that it can be moved easily, or it may be used without casters, as is more commonly done.

Figure 22.



Now frame is covered with cloth. If casters are used, cloth must reach to the floor so that audience cannot see under screen. On two end sections of screen, cloth is put on straight. Have middle panel made of decorated cloth, gathered or pleated enough so that a slit down through the middle of it will not be seen. Cloth may be put on loose and taken up with elastic on edges of slit to allow for stretching, if desired.

Figure 23.



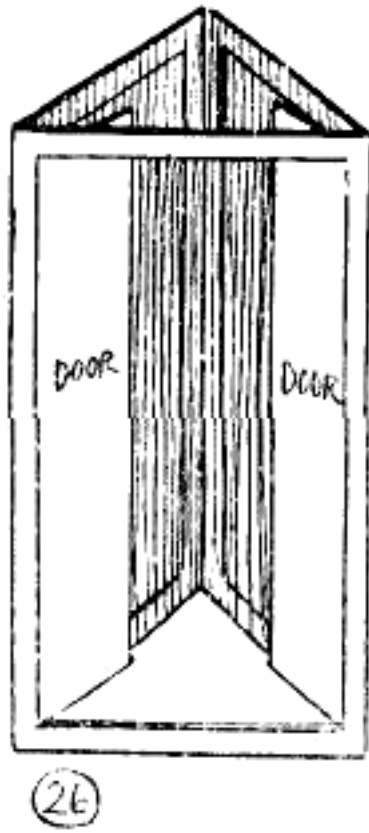
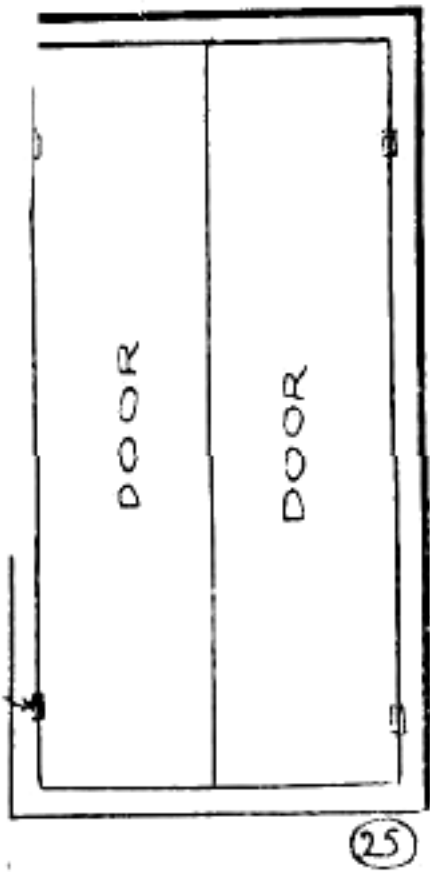
This slit must be so made as to allow a person to go through it easily. It must then close up again so that it cannot be detected.

Figure 24.

Screen may also be made of wood with two doors arranged in middle panel. These two doors are hinged inside to open inward. Doors should be fitted carefully into frame and then painted with a design so that they will look like a solid panel.

Figures 25 and 26.

Two doors in middle panel are fastened together with a catch to prevent their opening before time. Two sides of screen are painted and decorated to match



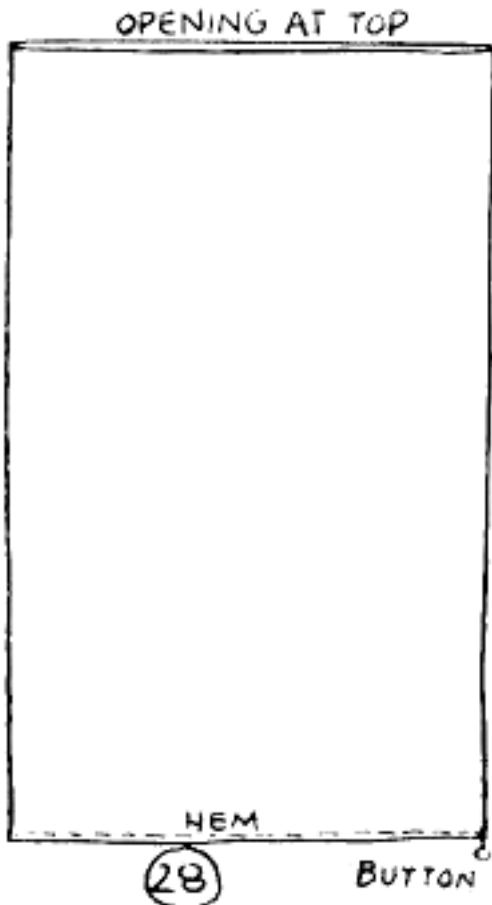
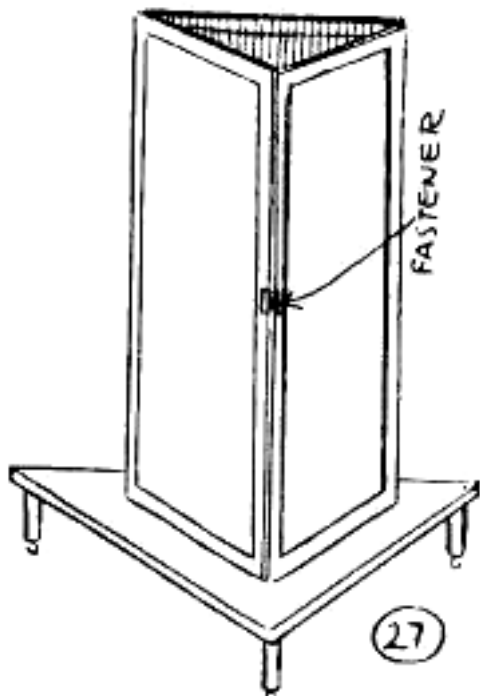
middle. Screen may be made into a neat and attractive piece of oriental furniture.

Screen may be placed on a platform, if desired, so that audience can see under it. In this case, performer walks

(51-10)

around edge of platform to make changes instead of walking on floor.

Figure 27.



3 -- A large cloth sack of opaque material, large enough to enclose a person and then tie over his head. The bag is open at top and bottom, but is basted together at bottom. To one end of basting thread a small button is attached so that it can be pulled out easily and bottom of bag opened. This is turned on inside of bag. Audience is not aware of this and believes bag to have a regular bottom.

Figure 28.

4 -- A piece of tape with which to tie bag.

Assistants Required:

One man and one woman. Two men or two women may be used if performer does not carry an assistant of each sex with him.

SECRET:

To Prepare:

Screen is placed on stage with middle panel to rear. Male assistant is inside, dressed in one of the Hindu costumes just as performer will be dressed.

Performer's Hindu outfit is placed on chair with the special cloth bag.

To Perform:

The illusion is performed in pantomime and no patter is required. If possible, have a music accompaniment.

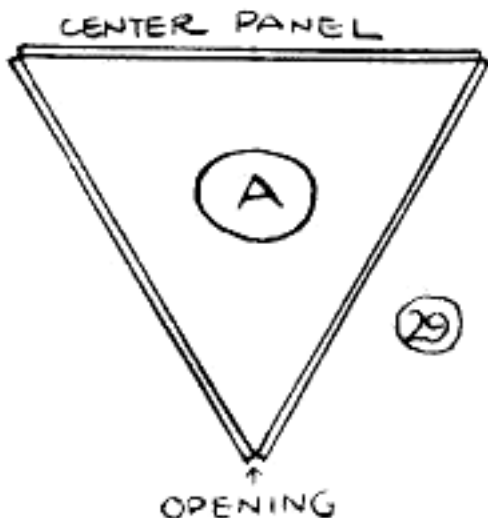
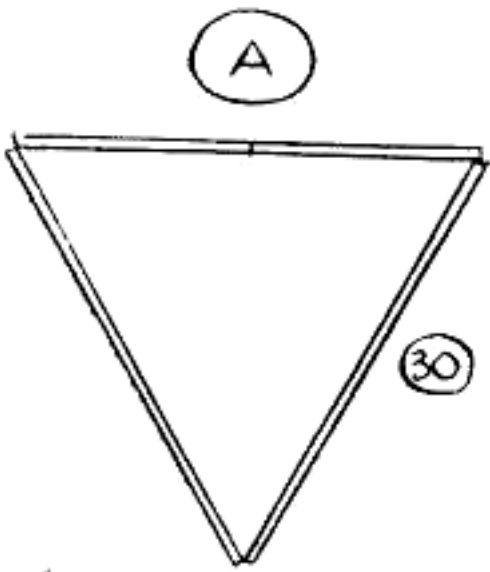


Figure 29.

Performer and girl assistant revolve screen to show all sides of it and move it to suitable spot near center of stage. Be careful not to lift screen and expose feet of assistant inside. Finally bring screen into position with opening at front and trick panel to rear. Note position of assistant (A).



When screen is in place, assistant steps through opening of rear panel to outside of screen. He then carefully closes opening in panel. Notice position of assistant (A).

Figure 30.

Performer opens screen to show inside of it. Sack is then shown inside and outside as an apparently unprepared

(51-11)



bag. Sack is now placed on floor inside of screen with top stretched out so that girl can step into it easily at proper moment.

Performer dons Hindu outfit. Girl steps into sack and performer pulls it up over her head, tying it at top with the piece of tape.

Figures 31 and 32.

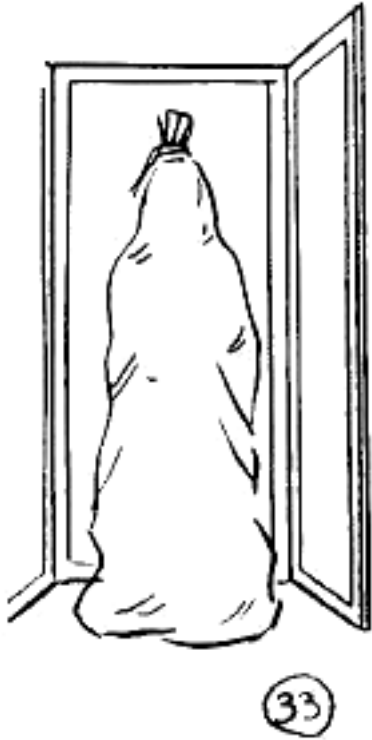
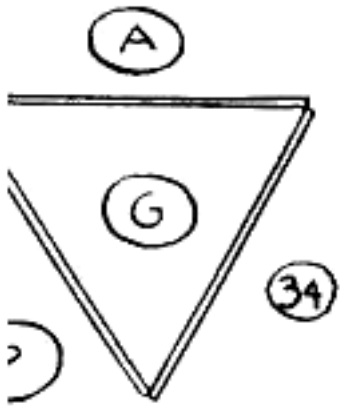
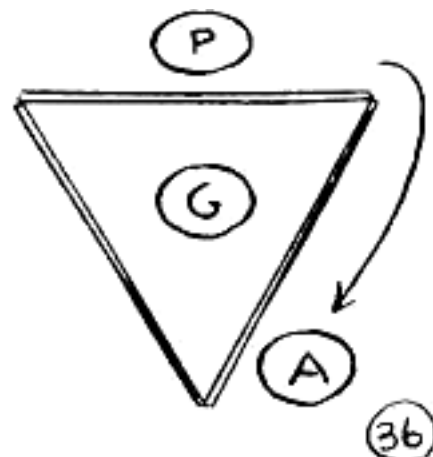
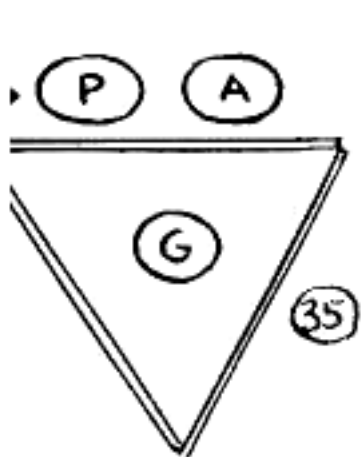


Figure 33 shows position of girl in screen.



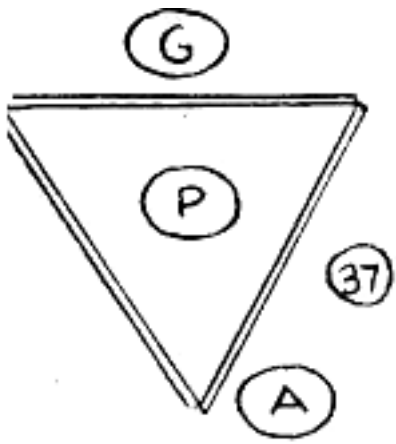
Performer now swings the two sides of screen together to enclose girl in bag and fastens them. Figure 34 is a diagram showing positions of Performer, Girl, and Assistant in relation to screen.

The moment screen is closed, girl crouches down, grasps button in bottom of bag and pulls out the basting thread to open bottom. She frees herself by pulling bag up over her head.



In the meantime, performer bows three or four times toward audience and raises his hands in a sort of oriental ceremony. He then walks around to back of screen. Instead of continuing to walk around, assistant comes out from behind screen to take his place. Audience is not aware of the substitution here and believes that performer merely walked completely around screen. Assistant turns back to audience and bows toward screen.

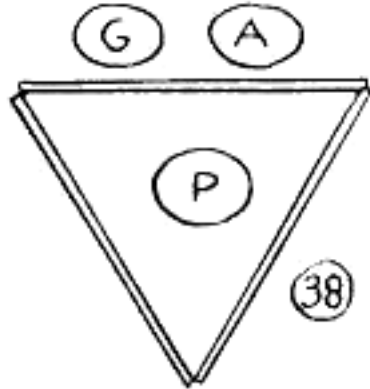
Figures 35 and 36.



During this time, performer quickly removes Hindu costume and gives it to girl to put on and then the whiskers and turban. Girl steps out of screen and performer goes in.

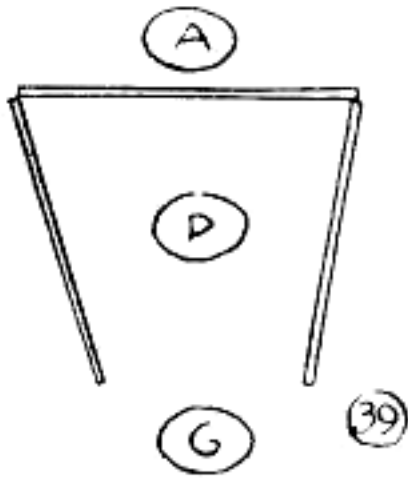
Figure 37.

Performer pulls bag down over his head and stands on bottom of it so that it looks just as it did when girl was in it.



Assistant now walks back to rear of screen again and stays there as girl, dressed as Hindu, comes out from behind it. This is the second substitution but audience still believes it is the performer walking around the screen.

Figure 38.



Girl goes through some ceremony just as performer and assistant did. Performer gives some signal to indicate that he is safe in bag and girl opens screen, revealing figure still in bag.

Figures 39 and 40.



Girl unties tape at top of bag and pulls bag down to reveal performer. As performer steps out of bag, she turns to audience and quickly removes Hindu outfit, revealing herself as the girl who was originally tied into the bag.

Figure 41.

Performer tosses bag aside and closes up screen. Male assistant steps into screen again through rear panel. Screen may be allowed to stand there or it may be removed to release assistant.

* * * * *

FIRST VARIATION -

In this method, girl is placed in bag and screen closed around her. Performer dressed as Hindu walks to rear of screen and stays there as male assistant dressed the same way comes out in front and goes through ceremonial. Performer gives his Hindu outfit to girl. The moment she is dressed, she gives a signal and male assistant walks off stage.

As soon as he is off, girl comes from behind screen, dressed as Hindu. She goes through ceremonial long enough to allow performer to get into bag in screen. The finish is then the same as the original version. Performer who apparently went offstage is found in bag and Hindu proves to be the girl.

* * * * *

SECOND VARIATION -

This variation permits the girl to appear in the audience at the finish.

After male assistant walks off in First Variation, girl walks out from behind screen. To audience it appears that the performer walked

off and then suddenly reappeared from behind screen. Now girl walks off stage. Male assistant removes Hindu garb and comes out as an assistant this time. Performer gets into bag inside of screen and girl rushes around to rear of theater or hall so that she can run down the center aisle at proper moment when assistant unties bag and reveals performer in bag instead of girl.

(51-13)

This method requires no special screen. An ordinary parlor screen with three sections can be used. Only two people are needed to perform this method.

EFFECT:

Performer dresses as Hindu. He places girl assistant in a large bag and ties the opening together over her head. A screen is placed in front of her. After some ceremony, magician removes screen and shows bag. When bag is opened, performer steps forth and Hindu removes disguise to reveal the girl.

PARAPHERNALIA:

- 1 -- A three-sided parlor screen. Be sure there is no space between the three sections.
- 2 -- Special bag with bottom basted as in original version.
- 3 -- Two Hindu outfits, exactly alike, consisting of black beard with mustaches attached to wire hooks for placing over the ears, Hindu turbans, and long coats.

SECRET:

To Prepare:

On upper frame of middle panel of screen place a small hook. This goes on the rear. On hook hang one of the Hindu outfits.

Have screen folded up, standing at side or back of stage.



Figure 42 is a diagram, showing arrangement of outfit and screen as if you were looking down on it from above. Costume is not visible to audience.

Have prepared sack and the other Hindu outfit on table or chair near at hand.

To Perform:



Show sack inside and outside, then place it on floor near center of stage. Girl steps into it and you draw it up and tie it over her head with tape.

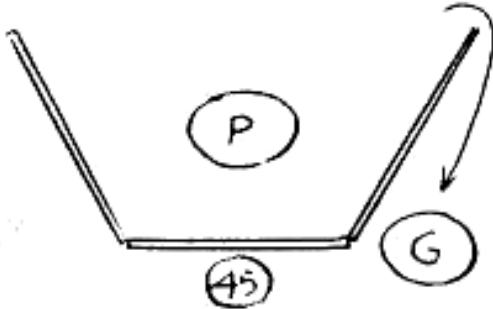
Get screen and place it in front of girl. Be careful not to expose costume on it. Now open the two outer panels and bring them around toward the rear to cover girl from the sides.

Figure 43.



When screen is adjusted, girl pulls thread from bottom of sack and lifts bag off. She then takes Hindu outfit from hook on screen and puts it on. In the meantime, you put on other Hindu costume out in front of audience where all can plainly see.

Figure 44.



You go through a bit of ceremony and then walk around to back of screen. Girl dressed just as you are walks out from other side of screen and does the necessary ceremonial. You quickly remove costume and hang it on hook on screen; then pull bag over head, stepping on the bottom of it to conceal it.

Figure 45.



At a signal, girl removes screen, folding it up as shown in Figure 42, and places it aside. She opens sack and out steps the performer.

Figure 46.

Girl removes Hindu garb and reveals herself.

* * * * *

NOTE:

Study the timing of each illusion perfectly. When passing back of screen for substitution, movements should be so timed that audience thinks you merely walk around back of screen. Do not draw any special attention to this walking around so that audience will not get suspicious.

Size of screens will vary with size of performers. The prepared screens are about three feet wide and six feet high. Some require them wider and some can use them narrower. Be sure screen you use is opaque.

Performer and assistants should be as nearly the same size as possible to avoid detection. Shoes of all must be the same color and similar in style.

Harlan Tarbell

TARBELL SYSTEM, INCORPORATED, Chicago.

* * * * *

LESSON 52

MORE ILLUSIONS. In this lesson you get a particularly interesting principle for production, vanishing, and transformation.

BUILDING ILLUSIONS

The illusions in this course have been selected with the greatest care so that they will be adaptable to your needs, whatever your position in magic.

For those students who will use them for temporary work, such as club, school, church, or local theater engagements, these illusions have been arranged so that they can be constructed at little expense by the student himself or by a local carpenter. These temporary illusions need not be taken apart for packing and thus can be nailed together permanently.

Professional illusion building is an entirely different field and requires a great deal of experience. There are many more problems to consider in constructing the professional illusion:

- 1 - It must be capable of producing a big, impressive illusion.
- 2 - It must be as light in weight as possible to save excess baggage charges.
- 3 - It must be so constructed that it can be taken apart easily and packed into as small a space as possible.
- 4 - It must be so constructed that it can be put together in a practical, speedy manner.
- 5 - It must be substantial so that it can be worked without danger of tipping over or exposing the inner workings -- also so that it will withstand the strain of the road.
- 6 - It must be the right size for satisfactory working.
- 7 - It must be artistic in appearance so as to make a good impression with an audience.

With all these angles to consider in professional illusion work, you can readily see the wisdom of securing the best the professional builder has to offer. Here is a case where the best is the cheapest in the long run. One good illusion will be more enduring and will bring you better results at less cost than a dozen poor ones. So to you who are going into illusion work, I say -- Buy the best illusion material possible and pay the price for it. It will save you time, patience, money, and perhaps a reputation.

TO TAKE CARE OF THE PROFESSIONAL ANGLE OF ILLUSIONS, WE HAVE MADE SPECIAL ARRANGEMENTS WITH EXPERT ILLUSION BUILDERS' TO CONSTRUCT ILLUSIONS FOR YOU. Through the Tarbell System, Inc., you will be able to get the best in illusions at reasonable prices. Order your illusions through the school as you need them and want them.

PACKING: After you have an illusion, be sure that you secure the proper crate, trunk, or other material to pack it in so that it will be protected in transit. The traveling case for an illusion should usually be made to order by the illusion builder.

BLACK ART ILLUSIONS

Black Art, in the mind of the average person, is associated with the Black Magic of old, which I discussed in the beginning of the course under the History of Magic. Another aspect of Magic which is associated with Black Art is work done on a dark stage, such as the acts of Paul Kleist and other magicians. In this work, a row of electric lights shines out in the audience's eyes and thus creates even greater darkness on the stage. Suddenly white objects appear and disappear. The secret of the illusion is to expose white objects, which contrast with the darkness. This is accomplished by assistants clothed in black who move about, invisible to the audience, removing black cloths from the white objects and covering them again. Many strange effects can be created in this way.

In discussing Black Art Illusions in this lesson, however, I am not going into the above type, but rather into a semi-black type. This is a special type of illusion in which the color BLACK is used as the illusion principle to cause a person to appear, disappear, or change into someone else. The principle is utilized by having dark spots in the light to gain the illusion. The audience is led to believe that everything is done in the bright light.

* * * * *

Apparatus:

Black Curtain

For this series, a black curtain or back drop is used or a special black screen. This curtain is best made of black velvet or velveteen as it has a surface which gives depth and inky blackness. For temporary purposes, black calico or sateen may be used. This curtain should be placed well to the back of the stage. It may be plain or decorated with bright colors around the sides and top and also at points here and there above the black part to be used in the illusion.

Black Art Chinese Screen

This is merely a frame which can be taken apart for packing. A frame about twelve feet wide and seven feet high is satisfactory. It may be decorated with Chinese figures around the edges for effect. The bottom edge is black. A black cloth which fits the frame is attached to it when it is set up. This screen may easily be set up where a curtain may be difficult to hang.

Ground Cloth

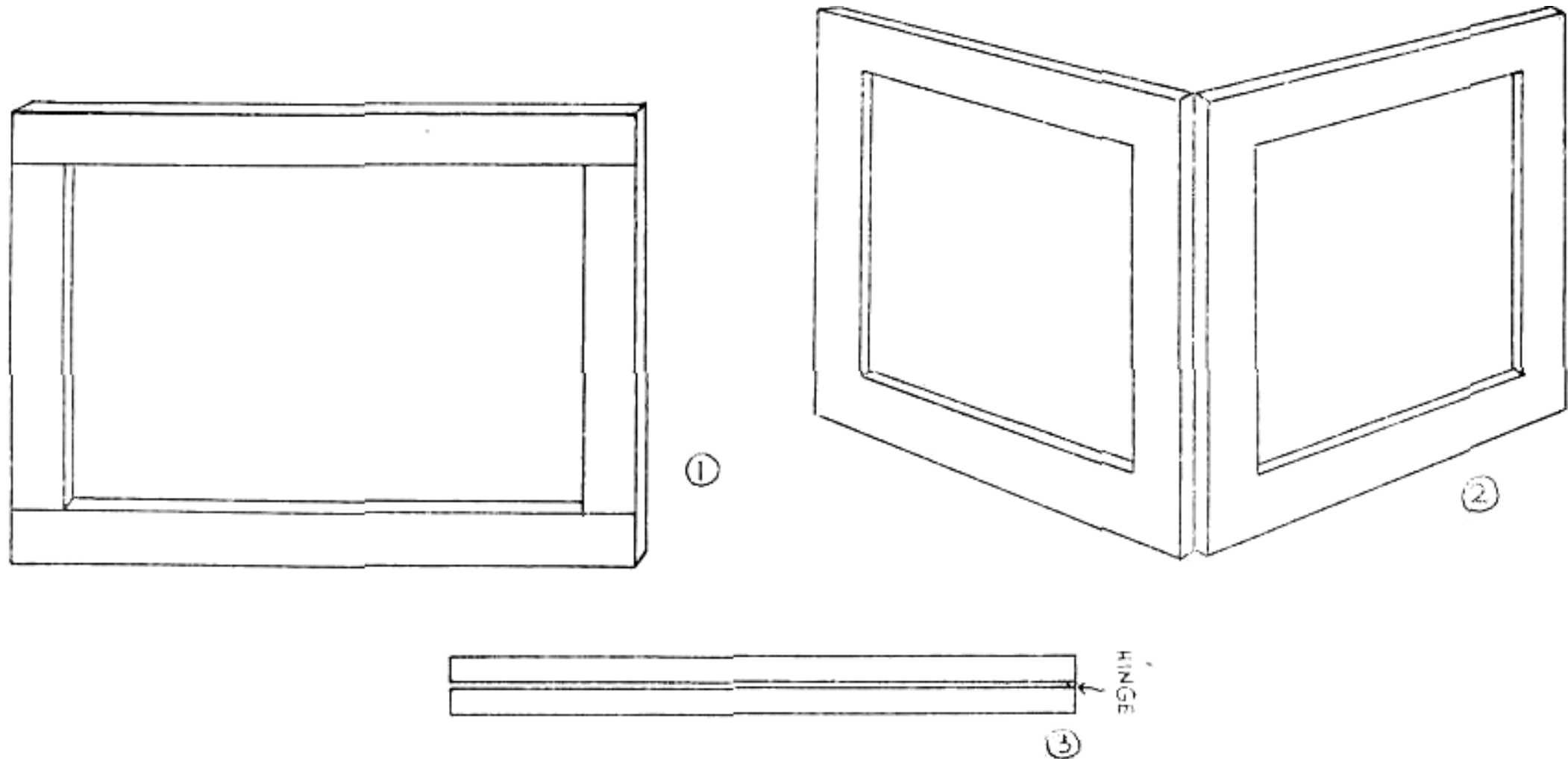
This is made of the same material as the curtain and is spread on the floor under the illusion proper so that people looking down will get the Black Art effect from the floor also.

Phantom Black Art Platform

This is an important piece of apparatus. Though simple in working, it is very effective. It lends itself as a utility piece around which many effects can be performed. Its purpose is to act as a table upon which magician or assistants stand and it contains the essentials for creating an illusion. It consists of two parts: the framework and the top.

The Framework: This is a skeleton-frame construction, consisting of two frames hinged together. Each frame is 26 inches high and 36 inches long. The boards are three inches wide and an inch and a half thick. The two frames are painted white on the front and sides and dull black on the back. The frames fold together flat for packing.

Figures 1, 2, and 3.



Simple as these frames look, they are tricked in the following manner:

Hidden in the upper board of each frame is a roller curtain. It is so arranged that when the two frames are opened at right angles and placed on the floor with the top over them, the doors or panels concealing the curtains automatically

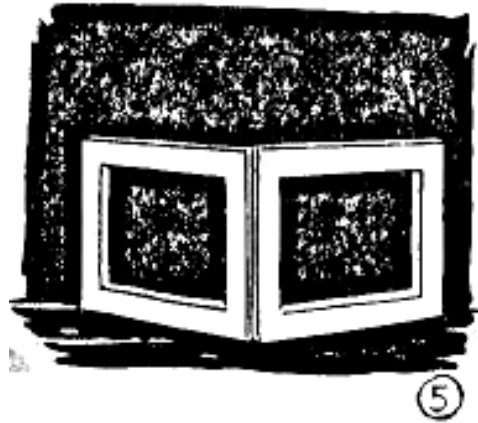
fly open and cause the curtains to fall down and cover the open spaces in the frames.

Audience can see through the frames before they are opened. Then when they are opened and placed in front of the back drop, the two small curtains fall down to cover the openings. Audience still believes that it sees open frames with the back drop showing through, when in reality it is only an illusion created by the Black Art frame.

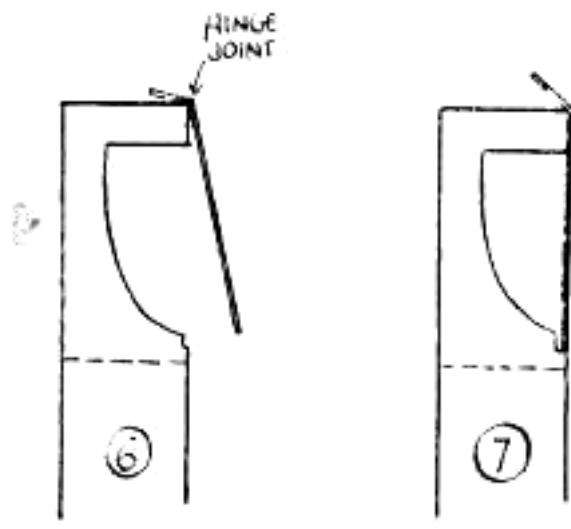
Figure 4 is a diagram of the position of the frame in relation to the back drop.



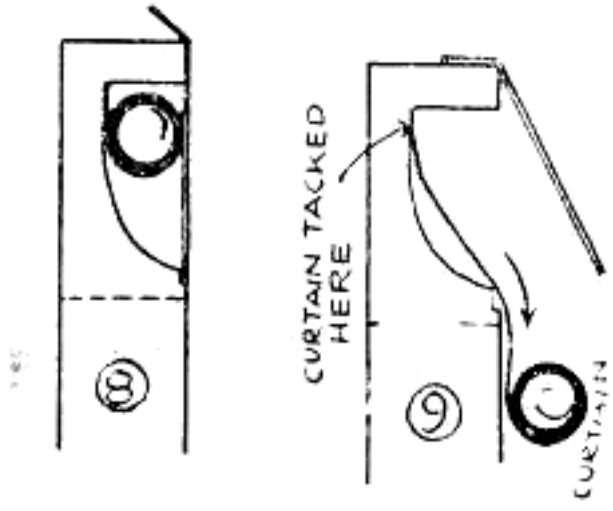
Figure 5 shows the frame as it appears to audience.



(52-3)



Figures 6, 7, 8, and 9 show diagrams of the frame construction for the curtain arrangement. The inside top edge of each frame is cut out to allow for the curtain roller. A hinge joint is then attached. One edge of curtain roll is tacked under top of frame and roll is secured under a panel.



When the two frames are folded flat together, the hinge joint on each remains up and holds the roller curtain in place. When the two frames are opened at right angles and the top placed on them, the hinge joints lift the panels and release the roll curtain so that it falls down straight and covers the opening in each frame.

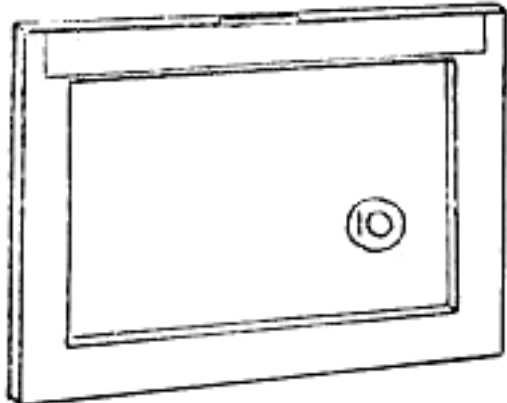


Figure 10 shows the frame as it appears with the curtain rolled up on the inside.

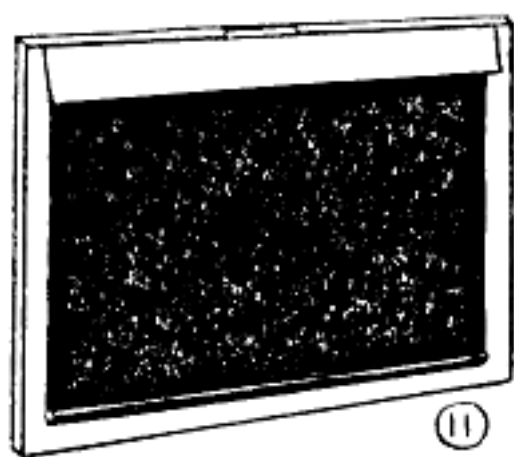
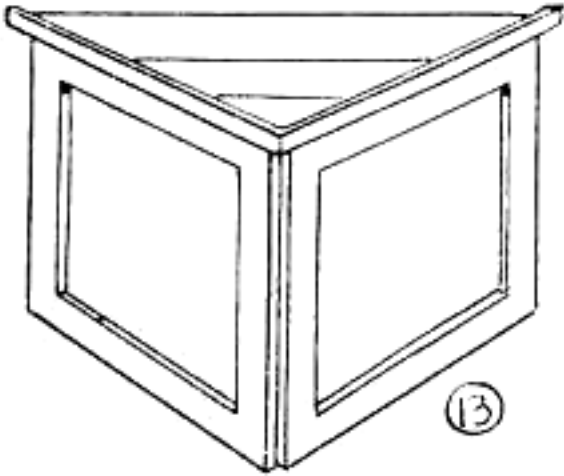
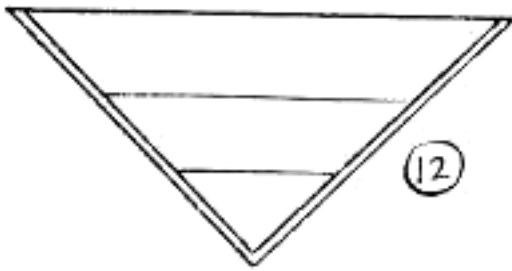


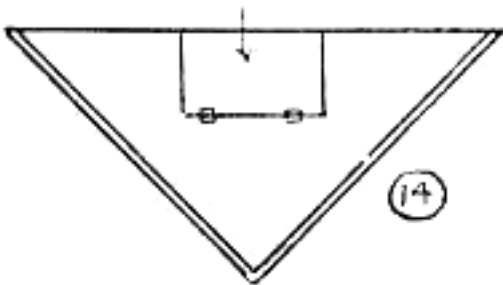
Figure 11 shows the frame as it appears with the black curtain covering the opening. This when placed in front of the back drop gives the illusion of looking through the open space to the back curtain.

The Top: This is a triangular piece which fits over the top of right angle made by open frames. It has a ledge on two sides, top and bottom, to brace the frames.

Figure 12 shows top. Figure 13 shows top adjusted on frames.

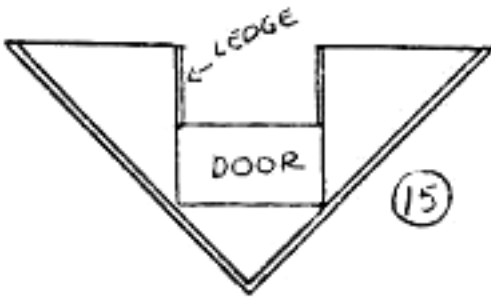


TRAP DOOR

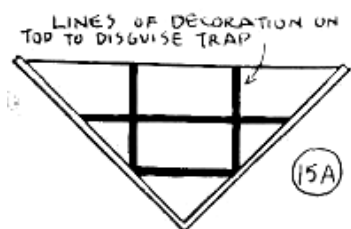


In the top there is a trap door. This extends inward from back of top about 12 inches and is about 18 inches wide. This door is hinged in the middle of the top so that it opens upward. Under the door there is a half-inch ledge to support it when someone stands on it.

Figures 14 and 15.



(52-4)



In order to disguise trap on top of platform, it is well to paint lines in black over top as shown in Figure 15A.

If desired, trap may be secured on outer edge with two catches between trap and rest of top to enable it to withstand severe handling. These catches may be opened when top is placed on framework during performance of the illusion.

A Handy Screen

This screen is designed to fit the Black Art Platform. When it is placed in front of a person standing on platform, that person can be made to disappear – or when it is placed on empty platform, a person can be made to appear.

The screen is in three sections for convenience in packing, though it may be made in two sections. In the three-section screen, each section is about 20 inches wide and 5 1/2 feet high. Between each section a narrow strip of cloth is placed to prevent anyone from seeing between the sections.

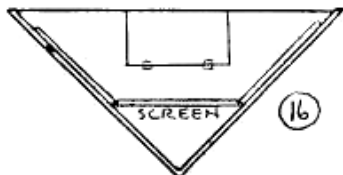
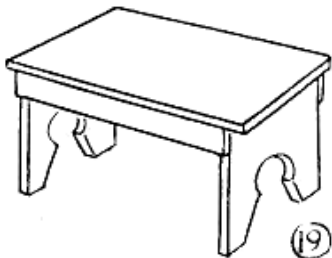
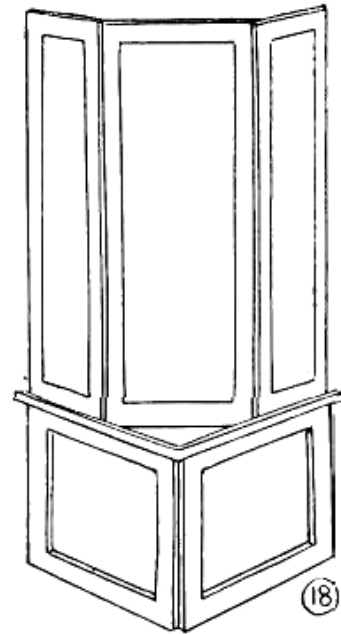
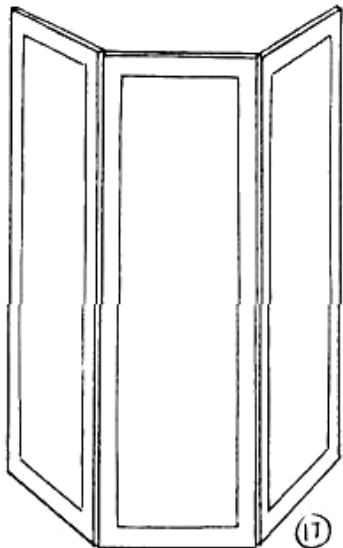


Figure 16 is a diagram, showing position of screen on top of platform. Ledge around top prevents screen from slipping off.

Figures 17 and 18 show the screen and its position on top of the platform.



A Serviceable Stool

A stool is a serviceable article to have in aiding one to step up on the Phantom Black Art Platform. It can be easily made and should be decorative enough to add to the stage setting. This stool should be about 18 inches long, 12 inches wide and 12 inches high.

Figure 19.

A Pistol

In illusion work, a small revolver helps to get a quick flash and a sharp noise. Blank cartridges are used, of course. does not like loud shots at a magical performance. A 22 pistol You must use judgment in the size of your pistol as an audience is best as it does not make too much noise.

Always examine your pistol before using it and NEVER FIRE IT DIRECTLY AT ANYONE. Even though you use blanks, you cannot afford to take a chance.

* * * * *

THE ELUSIVE HINDU

This is a fine illusion for the performer who carries with him a man assistant or for the woman magician who carries a girl assistant.

EFFECT:

Performer dresses as a Hindu. He shows a Phantom Framework and sets it up two or three feet in front of the back curtain. He walks behind it and audience can see his legs behind the frame. He places a triangular top on the framework and then gets a three-sided parlor screen. He stands on the Phantom Platform and places the screen in front of him. Assistant now comes out, wearing a cap and mustache and carrying a small revolver in his hand. He fires the revolver at the screen, then walks up and removes screen to show that Hindu has vanished. He now removes his cap and mustache and shows himself to be the performer who a moment before was dressed as a Hindu and vanished behind the screen.

PARAPHERNALIA:

- 1 -- Phantom Black Art Frame with Top and Handy Parlor Screen.
- 2 -- Black back drop and black ground cloth.
- 3 -- Two Hindu costumes, duplicates of each other -- with turbans and quick-change mustaches and beards. Mustaches are attached to beard and latter is mounted on wire to fasten over ears.

Figure 20.





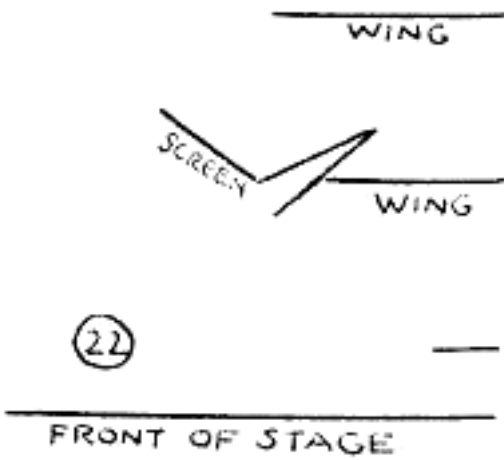
4 -- Assistant's costume. This may consist of a blue coat with high collar, a cap with a vizer, and neat mustaches. If desired, assistant's costume may also be Hindu, but the colors must be different so that this costume will be easily distinguished from the one worn by the performer at first.

Figure 21.

Performer and assistant should be as nearly the same height and build as possible. Shoes and trousers of both should be alike.

(52-6)

SECRET:



To Prepare:

Have Black Art Frame folded and placed to one side of stage. Place top with it.

Have screen opened a little, standing to left of stage. Right side of stage can be used if more convenient. Place screen with part of it extending back into the wings as shown in diagram of Figure 22.

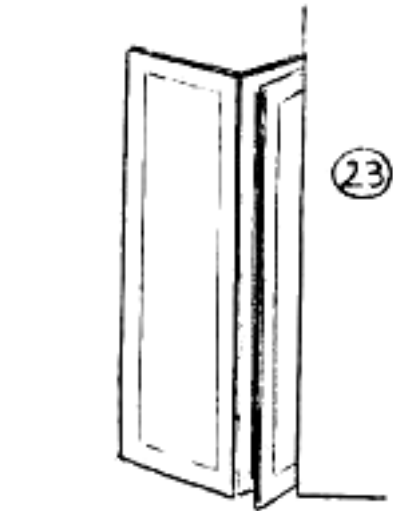


Figure 23 shows position of screen as seen by audience.

Place one Hindu costume on a chair offstage at the right and the other offstage at the left near the screen.

To Perform:

Assistant dressed in assistant's costume enters from right side of stage with chair, upon which is the performer's Hindu outfit. He places chair at right side of stage and exits. Offstage, he quickly removes his coat, cap, and mustache, and places them on a chair or table in readiness for performer later on. He then hurries back of curtain to left side of stage and hastily dons the Hindu outfit on that side.

When assistant has brought Hindu costume on stage and has made his exit, performer says:

"I shall present an odd illusion of the Hindus as it is performed in far-away India. In order to create the proper Oriental atmosphere, I shall dress as a Hindu."

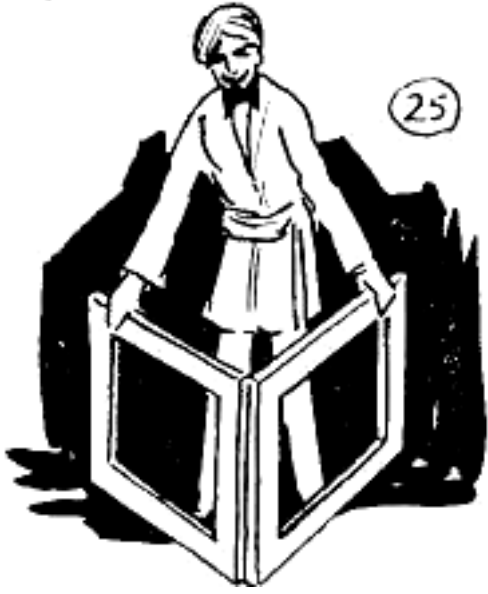
Put on coat and fasten it. Then place sash around your waist and tie it with a knot. Put on the mustache and beard. (These should be fastened together and adjustable with wires over the ears.) Place the turban on your head. Your movements should be timed in order to give assistant ample time to dress in his Hindu costume.

Now walk over to frame, pick up and show it freely. Open it to form a right angle, standing behind it so that audience can see through it. In this way audience is convinced that if anything were placed behind frame, it could easily be seen.

Then set frame down as shown in Figures 24 and 25.

Pick up Top. Stand in FRONT of frame and place Top in position. The moment Top strikes hinge joints on each frame, the panels are raised and the roller curtains drop down to cover openings. This is done quickly and your body in front of the frame helps to screen the dropping of the curtains.

Now walk over to parlor screen at left of stage and step behind it. Immediately your assistant, dressed as a Hindu, steps in front of you and places his hands on the edge of the



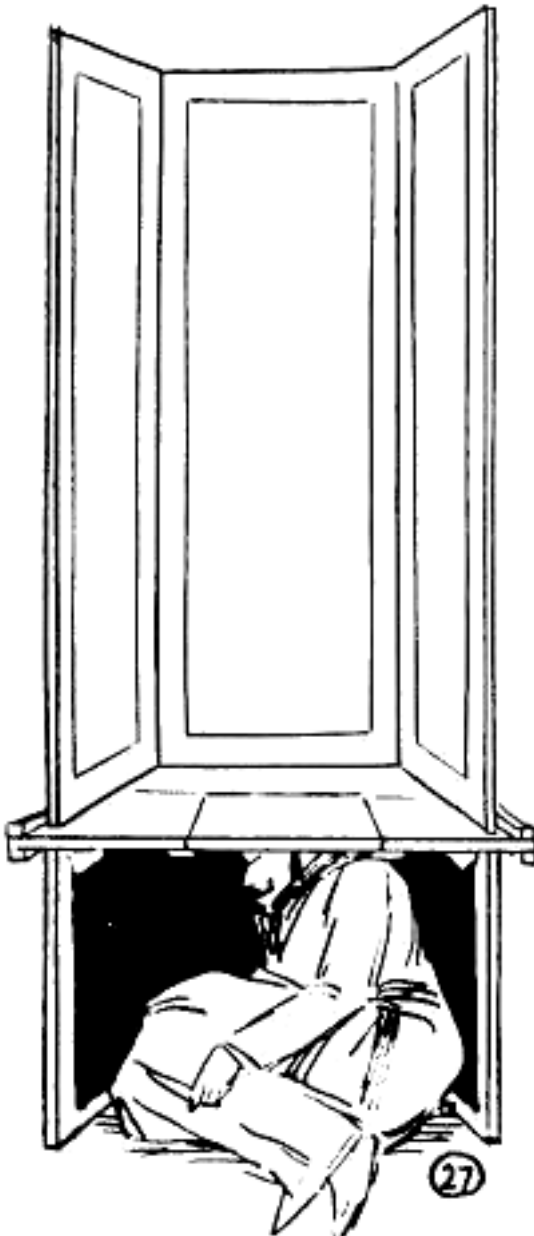
screen. As you go offstage, assistant carries screen out on stage.

Rush over from left to right side backstage, take off the Hindu outfit and put on assistant's first costume of coat, cap, and mustache, and take the pistol in your hand -- assistant turns back to audience and carries screen up to platform. Audience believes that performer merely walked behind screen to pick it up and carry it over to platform. Assistant, dressed as Hindu, is believed to be performer.



Assistant places screen down in front of platform, and with back to audience, bows once. He then steps up on platform and grasps screen so as to lift it up in front of him on platform.

Figure 26.



Assistant places screen in front of him on platform. The moment he is concealed, he steps to left of trap door of platform with his left foot and raises the door with his right foot. He then steps down through the trap, being careful not to expose himself from the sides of screen, and crawls down on floor under top of frame. He now pulls the trap door back in place.

Figure 27.

This should all be done very quickly and yet allow enough time for you to get into assistant's costume. As soon as assistant is concealed under frame, you step out from right wings, walk up to screen, and fire pistol into the air. Remove screen to show Hindu has vanished, fold it up, and place it on top of platform or allow it to fall to the floor.

Turn to audience, quickly remove cap with one hand and mustache with the other, and show yourself to be the performer.

* * * * *

NOTE: This illusion is a great one for closing a Chautauqua or Lyceum performance.

Speed up the illusion as much as possible. Practice it carefully with your assistant so that you can work in harmony and time your movements correctly. There must be no interrupted action or you lose your hold on the audience. Speed is essential in all illusion work.

* * * * *

A DAUGHTER OF THE SUN

This is a legendary illusion with a puzzling finish.

EFFECT:

A girl is placed in a kneeling position on a small altar and is covered with a cloth. Audience can see under altar and

(52-8)

can see girl move after she is covered, yet when the cloth is whisked away, the girl has vanished. She suddenly appears in the audience and comes running up the aisle to the stage.

PARAPHERNALIA:

1 -- A Phantom Black Art Frame and Top, to represent an altar.

2 -- A large cloth, about eight feet square, with a large sun painted in the center.

This cloth may be a bed sheet with an orange-colored sun and rays painted on it -- or a yellow cloth with orange-colored sun. (Or it may be just a plain white sheet.)

Figure 28.

3 -- A torch and pedestal to hold torch.

4 -- A specially prepared back curtain or screen with a trap door in the center back at the floor.

This trap is a frame with a door in it, opening from one side. It should be made of thin wood, yet built as substantially as possible so that a person can go through it without breaking it. Upper part of frame is attached to curtain or screen and lower part is fastened to floor backstage. The two parts should be hinged together so that they can fold flat and then braced at both sides with pieces which screw on and can be removed for packing.



The opening for door should be about 24 inches wide and 13 inches high. This door is hinged so that it swings both ways and goes back to closed position when released. It is covered with the same black material as curtain or screen so that it cannot be detected when closed.

Figure 29 shows front view of trap when open.

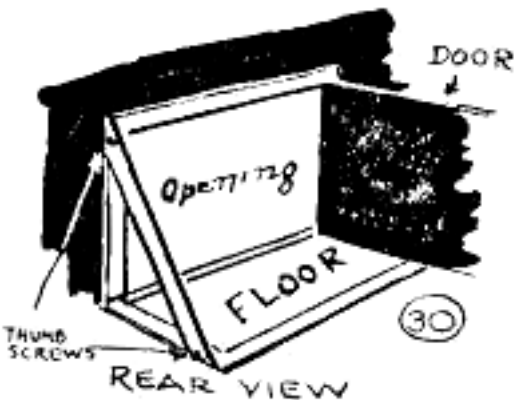


Figure 30 shows rear view of trap with door swinging backstage.

Framework should be screwed to floor to make it substantial and prevent motion of curtain when assistant crawls through opening.

Assistants: Two girls, about the same size. One man or woman additional.

SECRET:

To Prepare:

Have back curtain in place with trap door closed. Black Art Frame and Top are at center or side of stage.

The two girls must be dressed exactly alike. Chinese costumes with short coats and trousers are good outfits for illusion work as they are easier to work in than skirts.

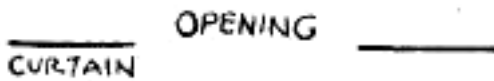
Figure 31.



Other style costumes may be used, however. The illusion can be made very effective with American Indian costumes and decorations.

Performer and other assistant may be in regular clothes or in the same style outfits as the two girls.

Place one girl in costume at rear of curtain, ready to come through trap door at verbal signal.



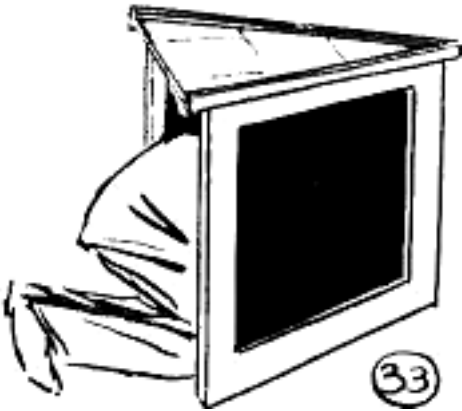
To Perform:



Assistant picks up frame and brings it over in front of trap door in back curtain. He stands behind frame and opens it so that audience can see through it, setting it down about two feet in front of trap door. You will have to study Angles of Visibility and convenience of working to determine just where you will find it best to place the frame.

Figure 32.

Assistant then places top on frame, causing curtains to drop down. He stands in front of frame while doing this. Next he places the stool at the right side of frame.



The moment curtains are down in frame, assistant gives a verbal signal. Girl comes through trap door and crawls under top of frame.

Figure 33.

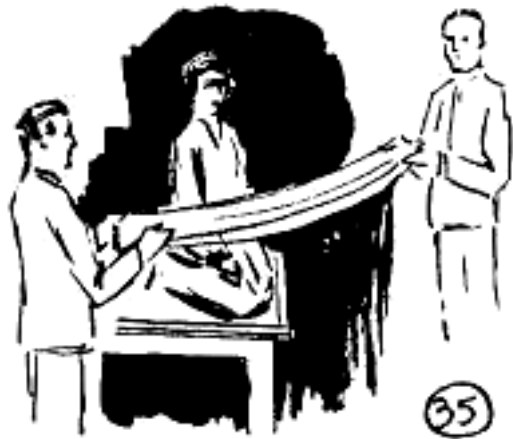
In the meantime, performer is addressing audience.

"There is a legend told of a certain cult of sun worshippers who once a year made sacrifice of the fairest and most beautiful girl of their cult, in the hope that the spirit of this fair girl would go up to the sun and become a daughter of the sun god. To become the daughter of the sun was a rare privilege. However, there came a time when a certain girl was chosen and offered for sacrifice and a strange thing happened. The story is best told in illusion."

Have other girl enter from right side. Her head is bowed. She stops a moment, turns to audience, raises her head, and then bows it again.

You take her hand and lead her to the altar, assisting her to get up on it. Girl kneels on it, facing audience.

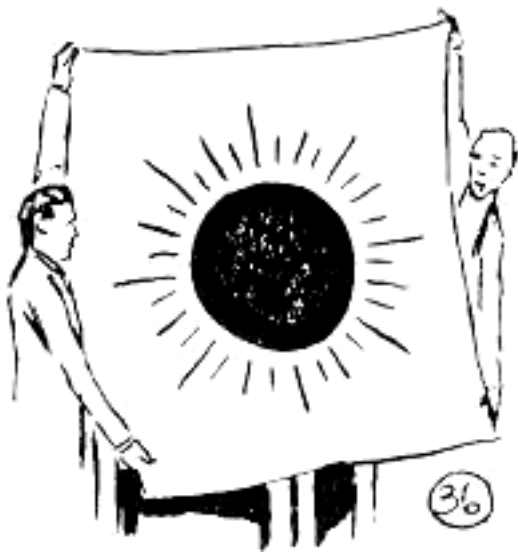
Figure 34.



Assistant picks up the cloth and gives a corner of it to you to hold. You stretch the cloth out between you in front of girl on altar. You are at girl's right and assistant is at her left.

Figure 35.

(52-10)



Now cloth is completely spread out to screen girl. Be sure bottom of cloth is a few inches below top of platform but not too low, so that audience believes it is looking through frame below. As soon as cloth is in proper position, girl slides down behind frame and out through the trap door in curtain. Other girl comes up from under frame and takes kneeling position on platform.

Figure 36.



Cloth is then dropped down over second girl. This must be performed without hesitation so that audience is not aware of any change in girls behind the cloth.

Figure 37.

Girl who is now free rushes around the outside to the back of audience in readiness to come down the aisle when called. The timing here must be perfect so that girl does not appear too soon in the audience or too late for good effect.

On the stage you adjust the cloth around the girl, folding it back a little to expose part of the girl's costume. This is to help the illusion further by convincing audience that girl is still there.

You bow to girl on altar several times and look up to sun. Assistant lights torch and places it on pedestal or holds it in his left hand.

You then walk to right side and assistant to left side of altar. Each grasps a rear corner of the cloth, then you both hold it straight up to screen girl. Girl on altar slides down quickly and crouches under top of platform.

The moment she is gone, you suddenly grasp cloth in a bunch. The girl is gone. You look at the bare altar and exclaim, "Gone!"

Figure 38.

You then call to her, "Ming Toy -- Ming Toy -- where are you?" Use some appropriate name here in accordance with costumes used.

Girl comes running down the aisle, exclaiming, "Here I am!" She comes up to stage. You take her hand and you both bow.



* * * * *

THE MYSTERY OF THE GIRL IN THE TRUNK

This is an ingenious illusion, making use of the Phantom Frame and an ordinary large trunk. The finish is a startling transformation.

EFFECT:

Performer shows open frame. He sets it up and places a top on it. He then shows a large trunk empty. Into the

trunk steps a girl and the lid is closed over her. Trunk is placed to one side of stage, away from everything. Magician now steps on platform, holding a sheet spread out in front of him. Suddenly a figure appears under the sheet in front of performer. He allows sheet to fall over this figure and he steps down from platform. In a moment he opens the trunk and out jumps a boy instead of the girl placed there. He whisks off the sheet from figure on platform and reveals the girl who a moment before was placed in the trunk.

PARAPHERNALIA:

- 1 -- Phantom Black Art Frame and Top.
- 2 -- Black back curtain and ground cloth.
- 3 -- Trunk, large enough for a person to crouch in comfortably.
- 4 -- Large cloth, about 8 feet square. A bed sheet will do in emergency.

SECRET:

To Prepare:

Place trunk at center back of stage, about three feet from back drop. Have Phantom Frame and Top at side of stage.

Place boy assistant down behind trunk so that he cannot be seen by audience.

Girl assistant should be dressed in Oriental costume with thin trousers attached to her ankles – or in some other suitable costume which will allow freedom of leg movement, unhampered by skirts. She should be in readiness offstage.

To Perform:

Pick up frame and top. Set top against trunk. Show frame and open it. Bring it over to right of trunk. Stand behind frame and open it. Set it down with one edge an inch or two behind right side of trunk. Audience can see your legs through frame.

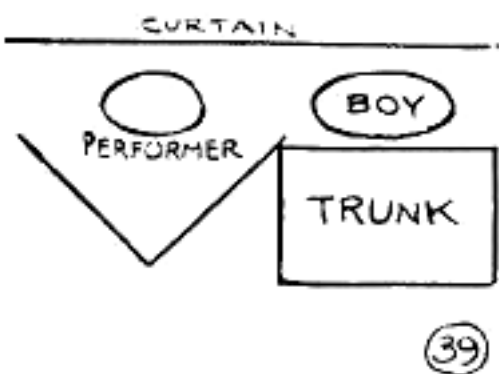
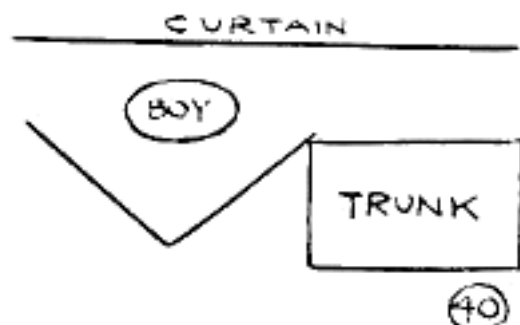


Figure 39 shows a diagram of positions of yourself, boy, trunk, and frame at this point.



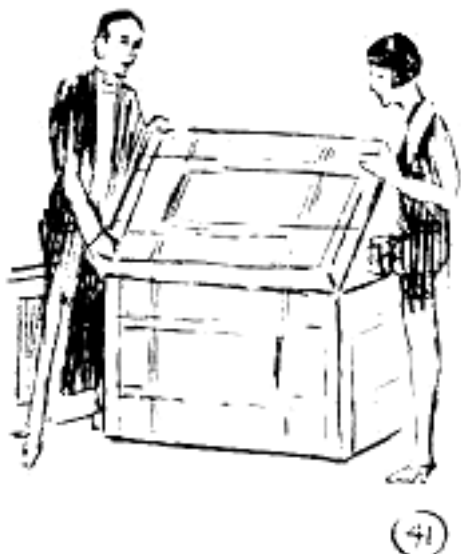
Now come around right side of frame to front. Pick up top and place it on frame, causing curtains to drop into position. The moment curtains have fallen, boy crawls from behind trunk to back of frame.

Figure 40.

Grasp handle at left side of trunk and pull it forward to front of stage. Open trunk, stand it on end, and turn it around to show it is empty. Strike it on all sides to convince audience it is an ordinary trunk.

Replace trunk against edge of frame as before, but this time have front of trunk toward back curtain so that lid opens toward audience.

Boy crawls behind trunk again as you lift the lid. Quickly the boy slips into trunk while your movements help to screen him from the side, and he crouches over in right side.



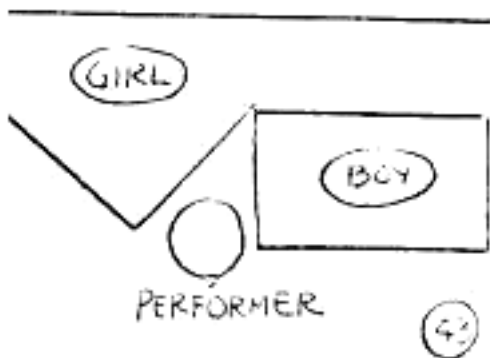
Girl assistant enters quickly and makes a slight bow to audience. She steps into trunk from left side, faces audience, and places her hands on top of trunk lid.

Figure 41.



While looking at audience, she quietly steps out of trunk backward, one leg at a time. Audience is not aware of this movement.

Figure 42 shows a side view.

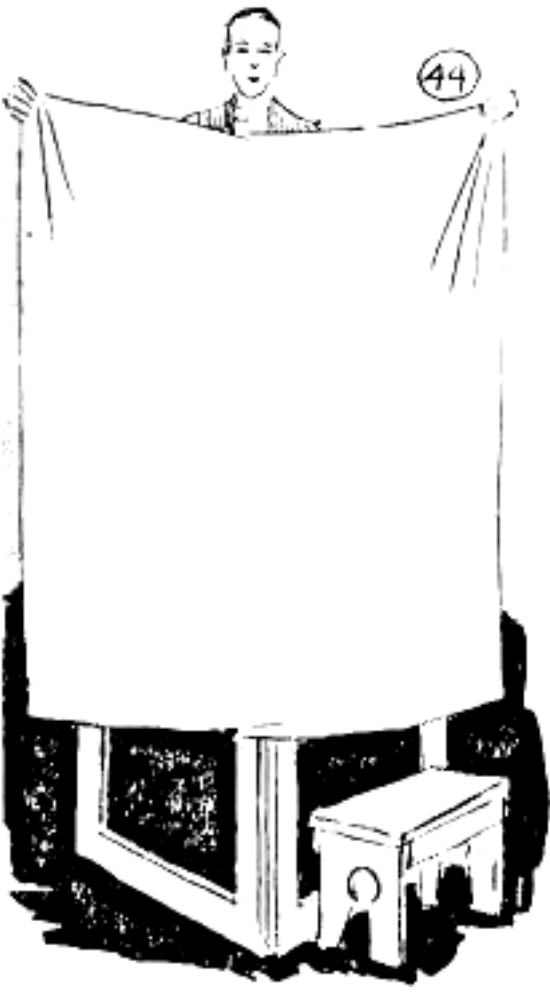


Girl crouches down behind trunk and then crawls over behind the frame. You place lid of trunk down over boy. Audience believes that you are closing the girl into the trunk.

Figure 43 is a diagram of positions at this point.

Now grasp left handle of trunk and pull trunk away from frame, bringing it down to side-front of stage. Turn it so that front of trunk is now toward audience.

To convince audience that girl is in trunk, go through the following: Knock on the side of the trunk and have boy inside knock in return. Have boy raise lid of trunk a little also. You may raise trunk lid a little and place a corner of a handkerchief under it so that boy can quickly draw it inside. Or an inch hole may be cut in side or top of trunk so that you can put corner of handkerchief into that and have it drawn inside by boy.



Next pick up the sheet and walk over to Phantom Platform. Step up on the frame from the side. Show sheet empty and then hold it spread out in front of you. Be sure that bottom of sheet comes a little below top of platform and yet leaves enough of the frame in view so that audience thinks it can still see through frame.

Figure 44.

Girl crawls up on to platform on your left and then stands up in front of you. You allow sheet to fall down and drape over her.

(52-13)



Figure 45 is a side view.

Step down from platform and come to center of stage. Point to figure under sheet. Point to trunk, and then walk over to it. Open lid suddenly. Up jumps the boy and steps out of the trunk. Trunk is then tipped on end and shown empty.

Walk over to platform and whisk away sheet, revealing the girl. Help her down from the platform.

NOTE: You have a very effective illusion here if you will speed it up and put pep in it. The finish is great. Study it enough to perform it in an artistic manner.

* * * * *

THE PHANTOM FLIGHT

This is a visible vanish, in which a girl vanishes before the very eyes of the audience.

EFFECT:

Girl stands on a platform. In front of her a three-sided parlor screen is placed. The middle section of the screen is made up of slats so that girl can be seen behind it. As she stands there, magician fires a pistol -- and in the twinkling of an eye, the girl vanishes. Screen is then removed and folded up flat.

PARAPHERNALIA:

- 1 -- The Phantom Black Art Platform.
- 2 -- Special Slat Screen.
- 3 -- Black back drop and ground cloth.
- 4 -- A pistol.

SECRET:

To Prepare:

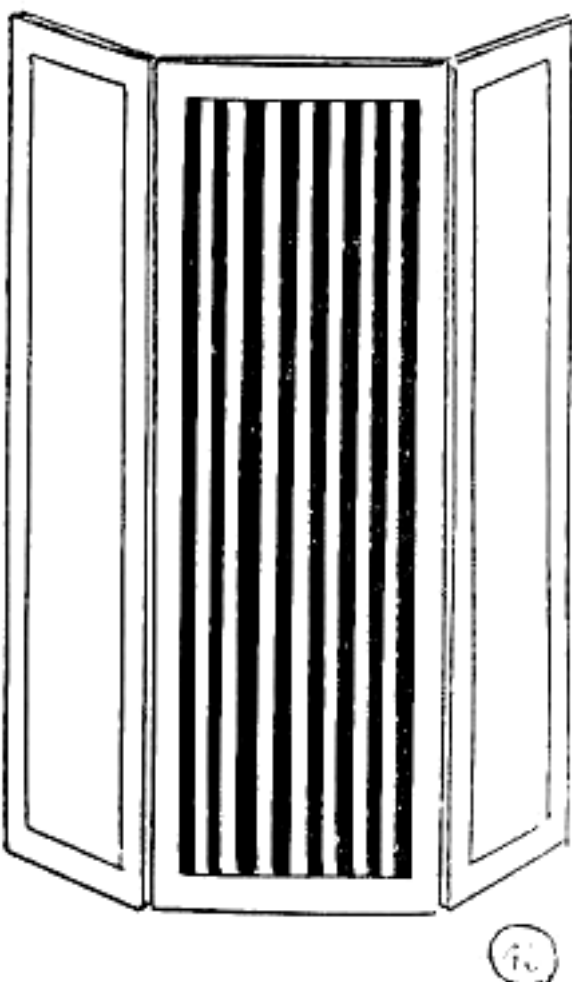
The Slat Screen:

This is a parlor screen of three panels, each about 6 feet high and 20 inches wide. It is similar to the Handy Screen already described, except that the middle panel is made of slat-work.

Figure 46 shows the screen as it looks when it is in front of the black back drop.

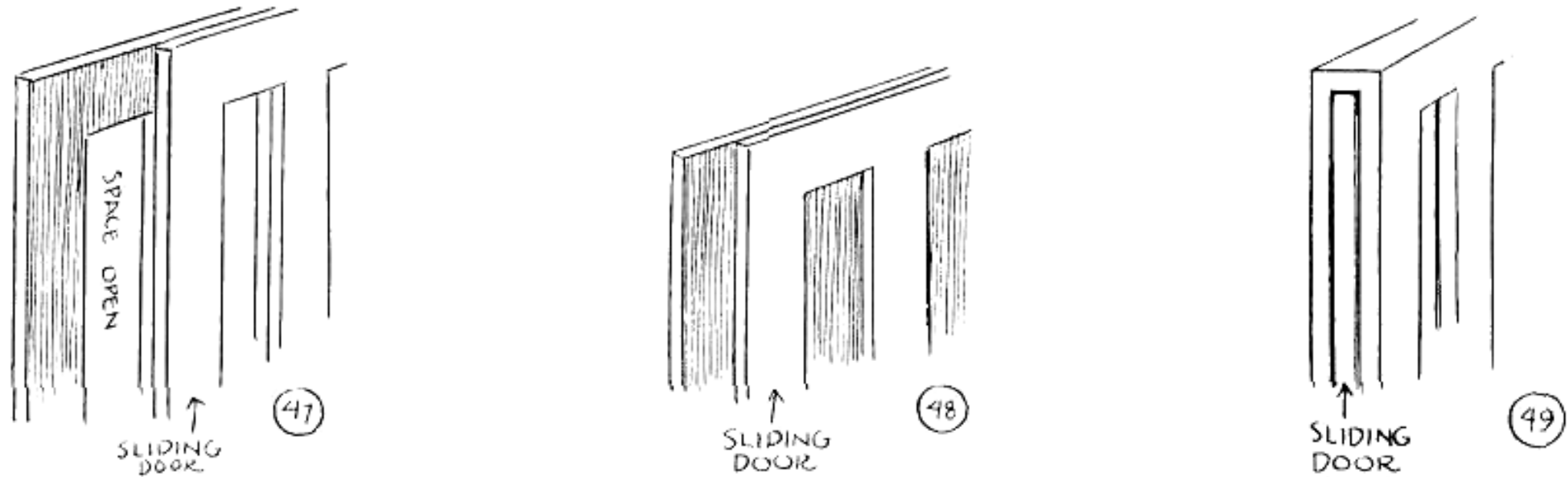
The slat panel is especially built for illusion work. Between the front and back of this panel, there is a sliding

(52-14)



door, also of slatwork, covered with black velvet. When front and back slats of panel are together, audience can see between them to the black back drop. When sliding door is slid over, the back slats cover the spaces between front slats. Slats and spaces are the same width. The velvet covering on the back slats now gives the illusion of open spaces and audience still believes it is looking between the slats to the black back drop.

Figures 47, 48 and 49 are diagrams, showing the construction of the slat panel, rear views. The first shows the slats of front and back part parallel with spaces open. The second shows the sliding door pushed over to cover spaces in front part. The third shows position of sliding door between front and back of panel.

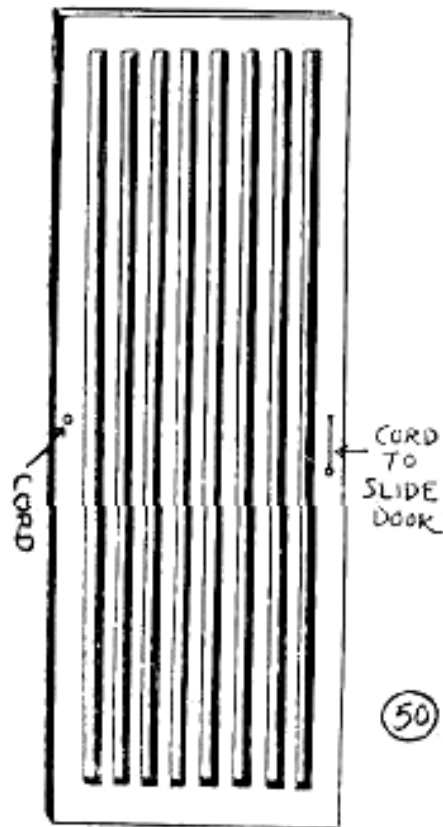


The sliding door is worked by a cord attached to each side of slat panel on back of screen. Cord at one side opens the slats and the other closes them,

Figure 50.

To get ready for performance, have the slat screen standing against something on stage – and have Phantom frame and top at hand.

Have girl assistant dressed in Oriental trouser costume or some other outfit which eliminates skirts.



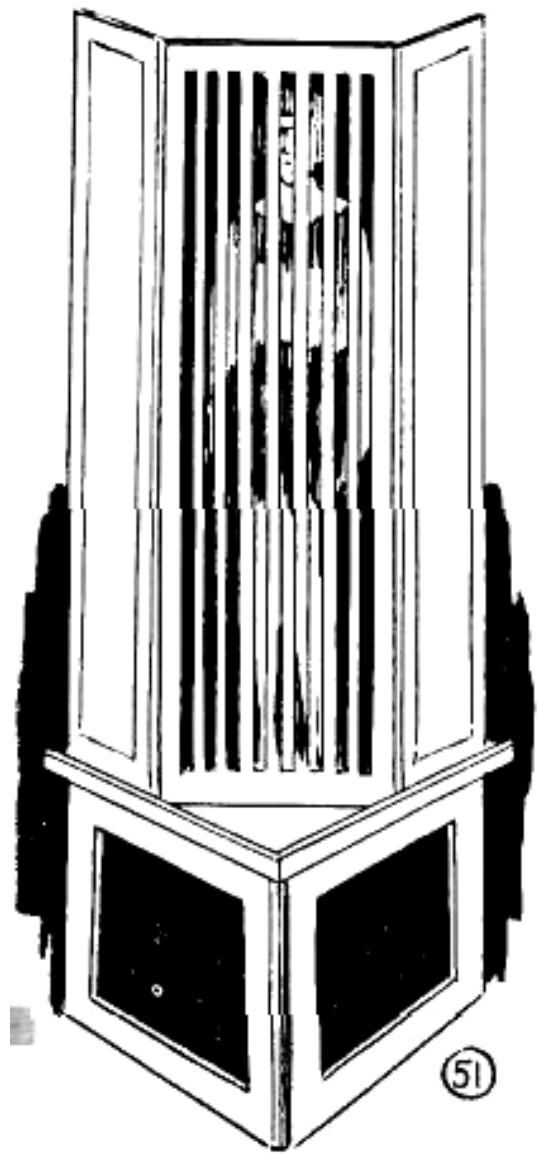
To Perform:

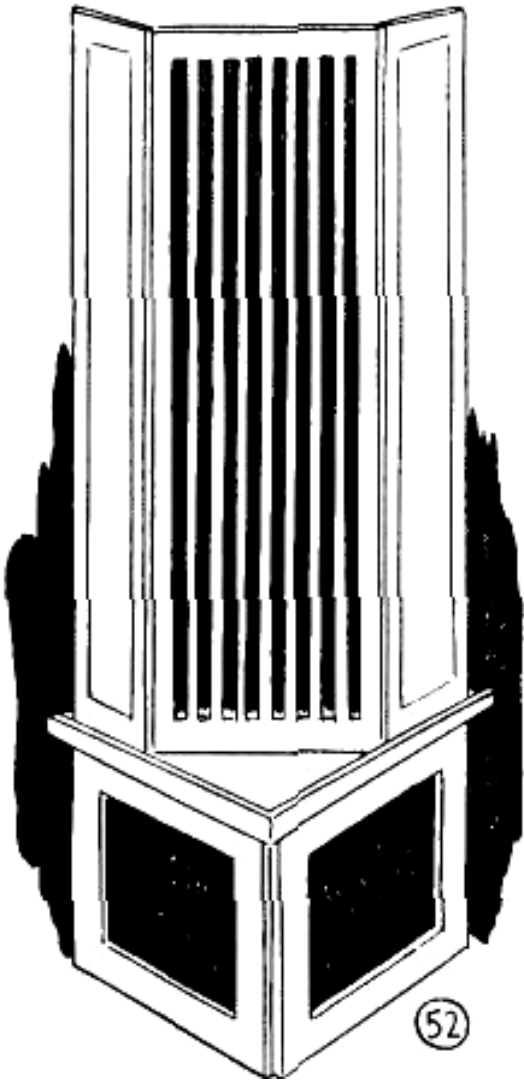
Set up the frame about two or three feet in front of curtain, in same manner as that taught to you in the preceding illusions. Place top on frame, allowing the curtains to drop into place.

Girl assistant comes in quickly and you assist her on to platform, where she takes a standing position. You then pick up the slat screen and place it on platform in front of girl. Audience sees girl through the slats and also sees the black back drop.

Figure 51.

You now step aside and call attention to the girl behind the screen. Pick up your pistol and fire into the air. The moment you fire, girl pulls string which slides rear slatwork





over spaces in front slatwork. Apparently she has vanished. Audience believes it is still looking between the slats to the black back drop.

Figure 52.

Girl quickly opens trap door in platform top and slides down under frame, closing the trap after her.

You step over to platform and fold up screen. IT IS VERY IMPORTANT TO FOLD SCREEN BEFORE REMOVING IT FROM PLATFORM so that audience will not notice that spaces between slats are still black when screen is taken away from black curtain. Or you may reach behind screen and pull string to bring slats parallel again and leave spaces between.

Remove folded screen and place it down on platform. This convinces audience that there is nothing concealed behind screen.

SUGGESTIONS:

You can build up many combinations for the above illusion. For instance, you could have two trap doors in the back drop a few feet apart. Place the slat screen in front of one, walking behind it to show audience that they can see right through it. Then pull string to cover open spaces in screen. Now set up platform in front of other trap door in curtain. Place girl on platform and cover her with Handy Parlor Screen. She vanishes, going out through trap door and across to other trap door. She comes out and stands behind slat screen. Upon your command, she pulls string which opens the slats. The illusion is that she has suddenly appeared behind the slat screen.

Or instead of using Handy Screen on platform, girl may be vanished under cover of cloth.

With costume changes, an impressive pantomime of transformations, appearances, and disappearances could be worked up with this illusion as a foundation.

Harlan Tarbell

TARBELL SYSTEM, INCORPORATED, Chicago.

* * * * *

LESSON 53

More and more illusions worked out for your advantage. Selections from the cream of the illusionist's art.

ESCAPE AND SUBSTITUTION ILLUSIONS

Popular in magic for many years have been illusions of an escape nature. Magicians are handcuffed, tied with ropes, placed in sacks, locked in trunks, nailed into packing cases, chained to boards, tied into straight jackets. In each case, escape seems impossible, yet in almost an instant performer releases himself without leaving any clue as to the method of his escape.

Houdini was one of the most popular of escape artists and a marvellous showman. No magician ever gained the amount of international publicity that Houdini did. He combined magic with legitimate escapes. Besides his magical knowledge, he knew locks and mechanics. With all this he combined the use of physical strength, contortion ability, ability to endure pain, and showmanship, and he became a master of magical and legitimate escapes.

Many people have attributed Houdini's escapes to the fact that he was possessed of a spirit power that enabled him to dematerialize his body and then rematerialize it. Even magazine articles have been written to that effect. Needless to say, Houdini was only human and performed his escapes by means which can be accomplished by a normal human being.

I could write a whole course on escape work alone. It is a whole branch of magic in itself. However, I shall content myself here with giving you a few important escape routines from which you can build others.

Speed is essential in escape work for a magical program. A legitimate escape often requires considerable time to perform, so to keep an audience's interest and convince them of your magic powers, the escapes are made by magic. Apparatus is tricked in such a manner as to allow examination without being detected. This apparatus enables the performer to work fast.

This is an age of action and craving for the unusual. People want to be swept along emotionally. If there is a break in their emotion or interest, the performer is apt to lose them. Therefore while the performer is out of sight and making his escape, good stage work by the assistant or music from the orchestra is necessary to bridge over the wait.

Escapes should be practiced over and over again so that they can be performed with the greatest speed possible and the audience kept at a high pitch.

* * * * *

THE SUBSTITUTION TRUNK MYSTERY

This escape illusion is in great favor for it seems to be accomplished with terrific speed. It is not as speedy as the

audience thinks, but the method of working at the psychological moment gives the impression of instantaneous escape work. Houdini, ably assisted by Mrs. Houdini, featured the Substitution Trunk Mystery for years.

The trunk used in this mystery may be used as a regular traveling trunk, then at a moment's notice it can be prepared for this startling illusion. Some performers carry the trunk carefully packed in a crate to protect it, but a trunk which shows use creates less suspicion and is more effective.

EFFECT:

Performer has a committee of two men come up from audience. They are asked to examine trunk carefully - to kick the sides, to hammer it, and see that it is just an ordinary trunk. Magician then asks one of the men to remove his coat and he puts the coat on himself. His hands are then tied behind him and he steps into a sack which is pulled up over his head and tied. Magician is now lifted into the trunk and the lid is closed down over him. The trunk is locked and strapped by the committee and placed in an enclosure on the stage.

The lady assistant now draws the two curtains which are in front of the enclosure in which the trunk was placed. She stands back of the curtains but keeps her head in view. She counts three and suddenly moves her head out of sight behind the curtains. At almost the same instant, performer's head appears. Performer opens curtains and has the committee bring the trunk forward. It is now unstrapped and unlocked by the committee and the lid is lifted. A figure in the sack stands up and the sack is opened, revealing the girl assistant. She is wearing the coat of one of the committee, which the performer put on originally, and has her hands tied behind her back. She is assisted from the trunk, her hands released, and the coat returned to the member of the committee.

PARAPHERNALIA:

- 1 -- A Substitution Trunk.
- 2 -- A cloth sack, large enough to cover performer.
- 3 -- Tape to bind sack.
- 4 -- Cloth tape to bind hands together.
- 5 -- Special cabinet with cloth sides and front curtains to screen trunk while illusion is being performed. In emergency, parlor screens may be used to conceal trunk or a curtain may be pulled in front of it.
- 6 -- Three leather straps to fasten around trunk.
- 7 -- A small, flat pocket flashlight for performer and one for girl assistant.

The Substitution Trunk:

This trunk is specially constructed. It can be closely examined and appears to be an ordinary trunk, but at the back

there is a cleverly concealed door. Even when the trunk is locked and strapped, an escape can be made from it through this door.

The trunk is 40 inches long, 26 inches wide, and 28 inches high. The trunk is bound with wooden slats. Figure 1 shows front of trunk.

Figure 2 shows rear of trunk. The slat going around the middle of the trunk helps to conceal the top of the secret door. The metal binding around sides and bottom of trunk help to conceal sides and bottom of secret door.

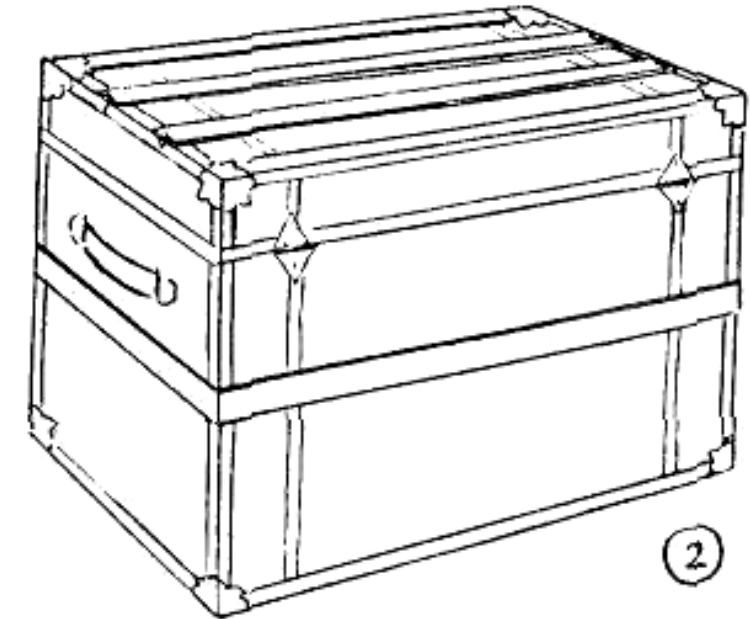
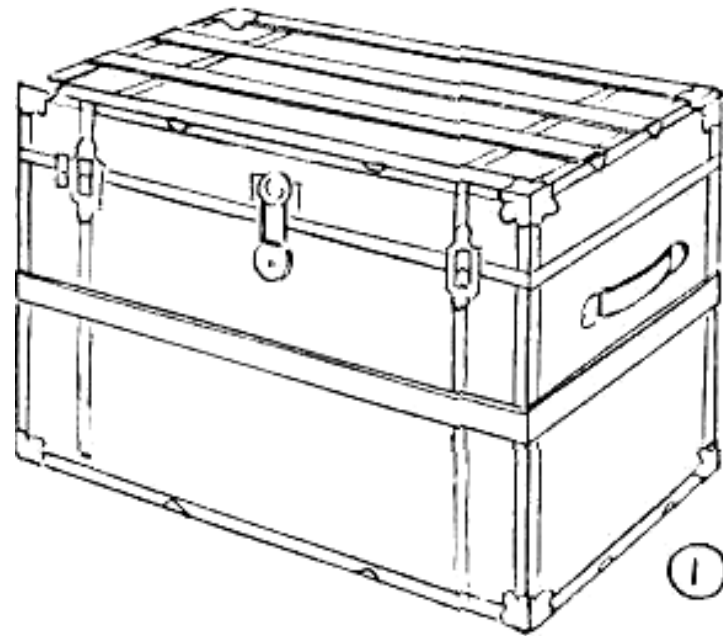
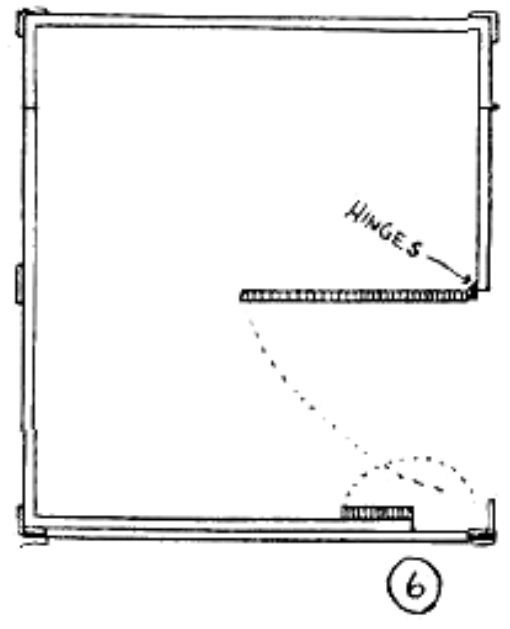
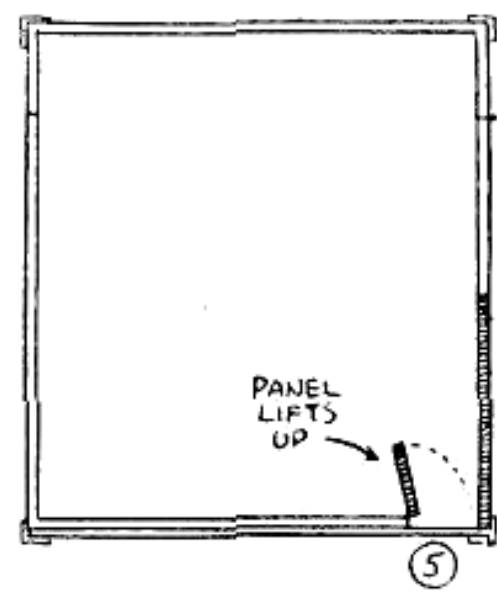
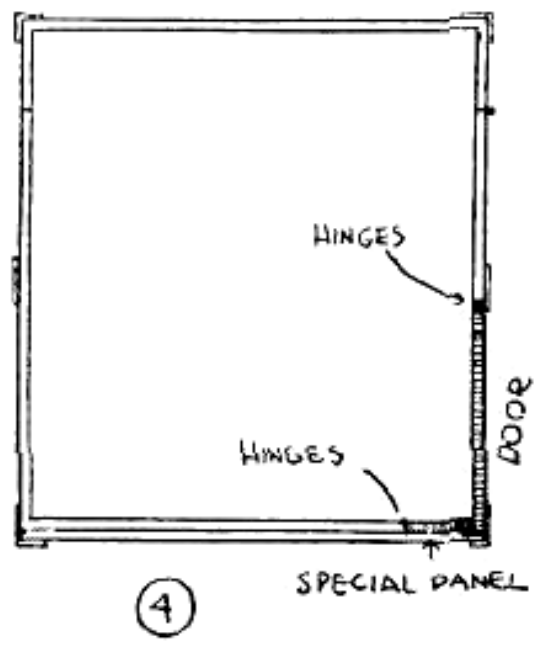
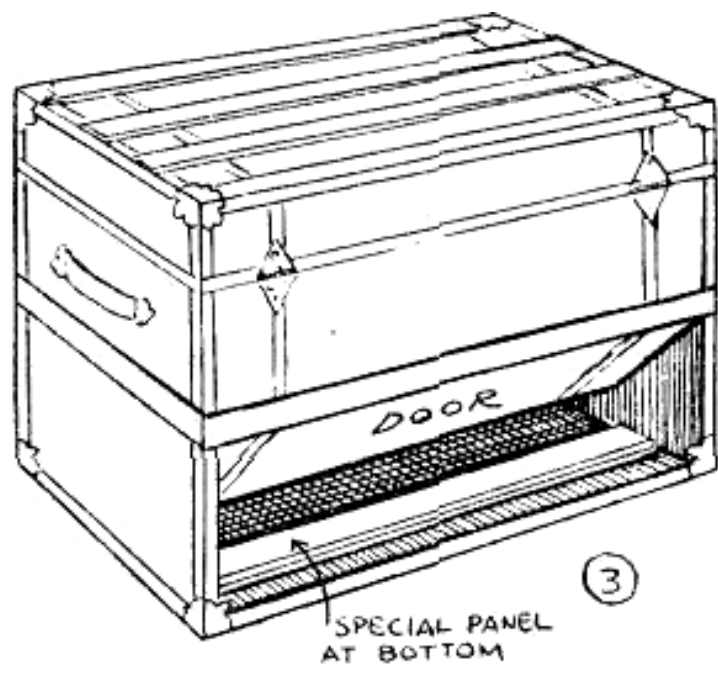


Figure 3 shows secret door partially open. To keep door from pushing inward before time, bottom of trunk has a special hinged panel, about five inches wide and running the length of the trunk at the back.

Figure 4 is a diagram, showing a cross section of the trunk from one end. It shows the secret door in place with the special panel in position to hold door.

Figure 5 shows panel lifted. This is done by inserting a buttonhook in the small ring which is in center of panel.

Figure 6 shows secret door open. It opens inward and upward and is also raised by inserting a buttonhook in a small ring at the bottom of it.



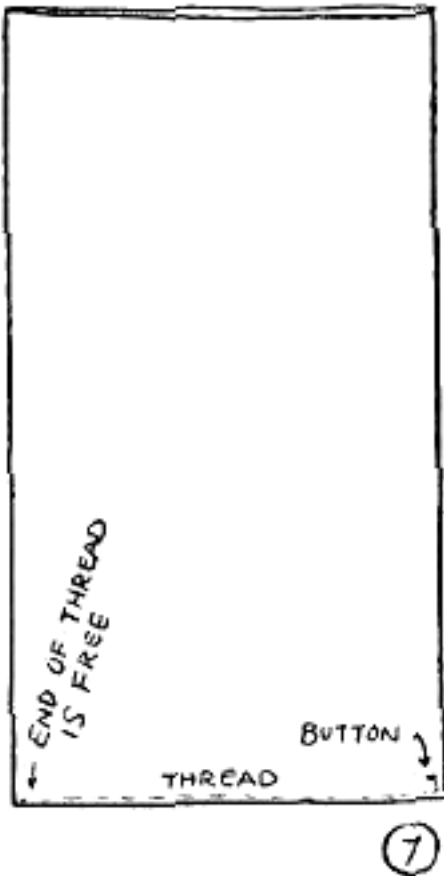
(53-3)

To close door, it is allowed to drop into place and the panel is forced down against it.

The hinges in these secret arrangements are, of course, sunken and are not visible. The inside of the trunk is heavily lined to cover up any cracks and hinges.

This trunk will withstand use on the road with things packed in it, and yet when unpacked, it becomes a valuable piece of apparatus for a rapid escape illusion.

The Cloth Sack:



This should be a straight cloth sack, about three feet wide and about six feet long. The bottom is left open and then basted with black thread. Tie a large knot on one end of thread or sew a small button to it. This should be on inside of sack so that person in sack can grasp button and pull out basting thread easily.

Figure 7.

The Tape:

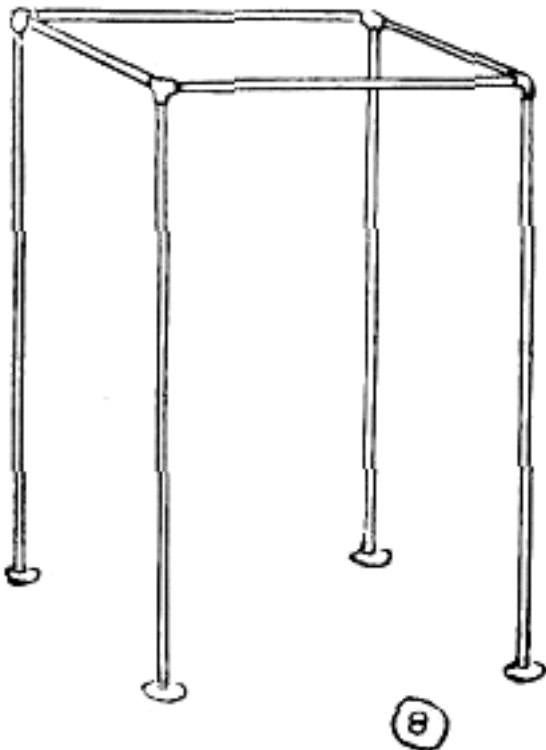
This should be cloth tape about half an inch wide and about two feet long to tie around top of sack.

Tape to Bind Wrists:

This should also be half-inch tape, about two feet long.

Special Curtained Cabinet:

It is necessary to screen movements during performer's escape and entrance of girl into trunk so the curtained frame has come into popularity. This frame is five to six feet square and six to six and a half feet high.

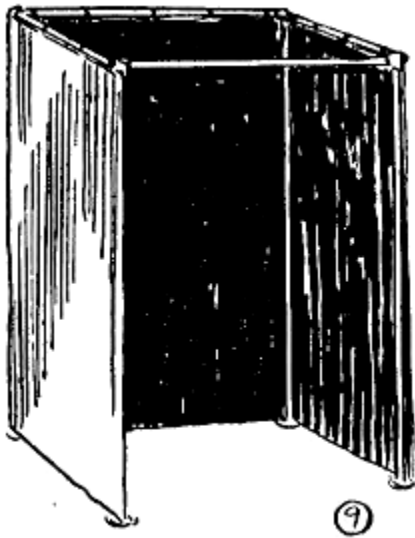


The frame itself is usually made of gas pipe with threaded ends which can be screwed into joints at the top and flanges at the bottom. Thus frame can be taken apart and carried in a compact form. Any good mechanic can make this frame. A wooden frame may be used or a frame made of metal rods, but the important thing is to have it substantial.

Figure 8 shows frame set up.

A cloth curtain big enough to go around three sides of frame is arranged with hooks around top edge and hung on top bars of frame. Curtain is not attached at bottom but each end is fastened to front vertical bars to keep from pulling away from sides.

Figure 9.

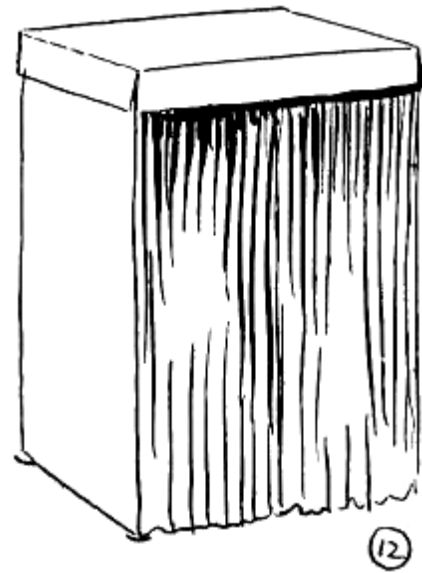
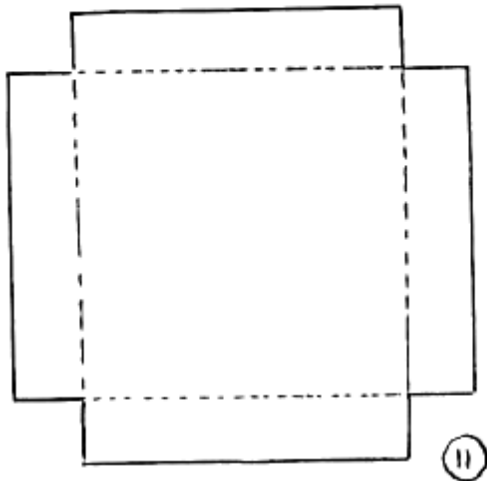
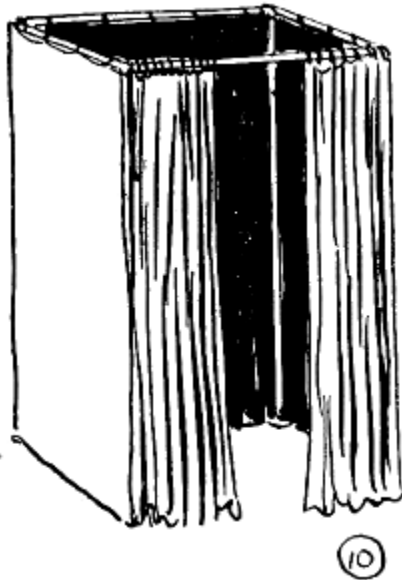


Across front of frame are two curtains attached by rings to top bar. These curtains slide easily and they are extra wide and full so that when they come together they can overlap. One edge of each curtain is fastened to side bars to keep from pulling over from the sides.

Figure 10.

A piece of cloth, shaped as shown in Figure 11, is fastened over the top of the cabinet.

Figure 12 shows the cabinet when it is completed.



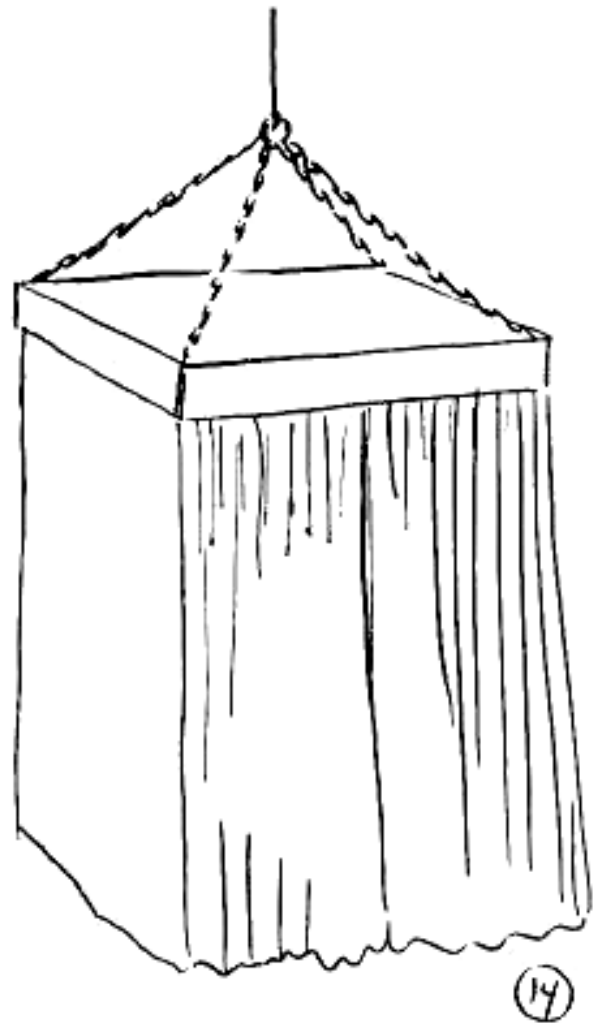
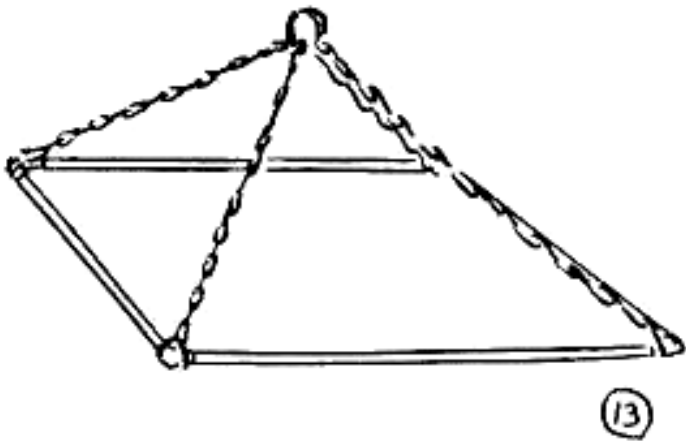
Swinging Curtained Cabinet - This style is popular in the theater or in a place where a cabinet can be suspended from a wire hanging down from above.

The frame used is the same as described above, made of pipe or rod. Chains are fastened to each corner of top of frame and brought together in a central ring.

Figure 13.

A wire is suspended from above and cabinet is hooked to the end of it by the central ring.

Figure 14.



Straps for Trunk:

These straps should be of leather and fairly wide. One should be long enough to go around trunk the long way and two to go around the narrow way. Each strap should have a strong buckle on it.

SECRET:

To Prepare:

Have curtained cabinet set up in center of stage. Front curtains are opened fully. Side and rear curtains may be thrown back so that spectators can see around and behind cabinet.

Trunk may be in center of cabinet. On a chair to one side should be the tapes, straps, and cloth bag.

Place chair on each side of stage for the committee of two from the audience.

Both you and girl assistant have small flashlights concealed in clothing.

To Perform:

Have two gentlemen come up on stage to assist. Shake hands with each and lead each one to a chair on stage.

Go to cabinet and pull trunk out a few feet. Ask the gentlemen to come forward. Turn trunk around, striking it and kicking it to show that it is solid. Have one of the men do likewise. Then open trunk and tilt it so that audience can see inside. Have one of the men strike inside of trunk. When gentlemen are convinced that all is fair, set the trunk about three or four feet in front of cabinet with the lid open and front of trunk to audience.

Say to one of the committee:

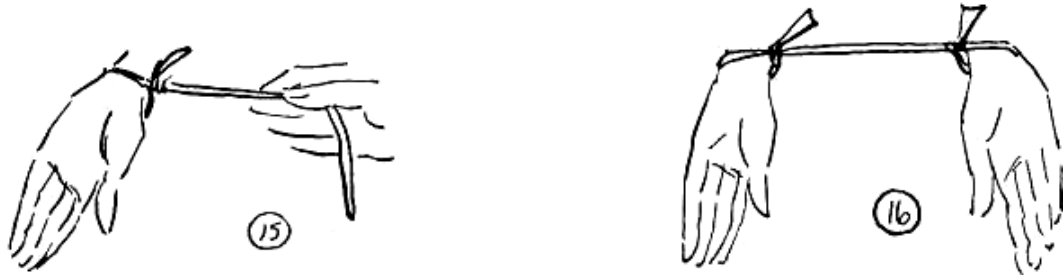
"Now, sir, I should like to borrow your coat. Remove the contents of your pockets, if you choose, or just leave everything intact."

You take coat from gentleman and slip it on.

"You would know your coat again if you saw it, wouldn't you?"

Girl assistant now picks up piece of tape and you hand it to gentleman with the request that he tie one end around your wrist -- then the other end around your right wrist. Hands are tied behind your back.

Figures 15 and 16.



When tapes are tied in this manner, the right knot automatically becomes a slipknot. It can be slid over and tape removed from right wrist very easily. Knot at left wrist can also be pulled into a slipknot. It is easy to do this if you hold one end of tape while gentleman is tying your wrist with the other end. However, in emergency, knot on left wrist can be untied and quickly tied into a slipknot when you are in the trunk.

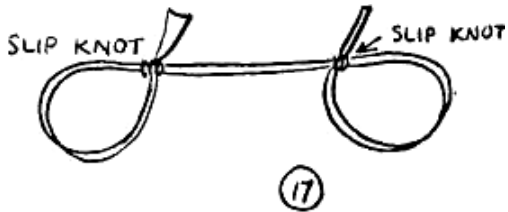


Figure 17.



Show audience that your hands are securely tied together. Assistant has bag ready. She shows it inside and out and then holds it down on the floor so that you can step into it. Assistant then pulls bag up over your head and hands one of the gentlemen a piece of tape with which to tie the top of the sack together.

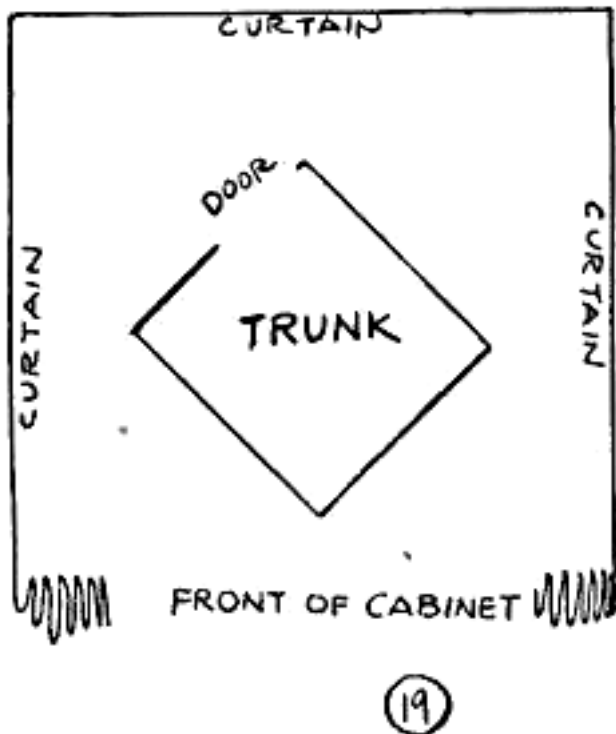
Figure 18.

When you are concealed in the sack, test the tapes to see that they can be moved easily. Remove them from your wrists but keep hands in same position behind you.

Have the two gentlemen lift you into the trunk. You crouch down and lie over on your left side with your knees pulled up as girl closes lid of trunk down. Assistant then has the two men lock the trunk and put the straps around it. The key is then given to one of them to hold.

The moment lid is closed, put tapes in right coat pocket, reach down to bottom of bag and pull out the basting thread to open it. If you need it, use the flashlight to help you. Pull

the bag from over your head and place it in one side of trunk with opening in position for girl to crawl into.



In the meantime, girl is directing gentlemen on how to strap the trunk. She then tells them to place the trunk in the center of the cabinet and stand it on end so that performer can stand upright. The trunk should be placed diagonally so that one corner of it faces directly front. The back of the trunk is to the rear. While most performers crawl out with trunk in horizontal position, it is easier to get out when it is in the vertical position, which I have suggested. The angle which I suggest in placing the trunk also helps to cover movements of girl in getting in should the curtains open accidentally.

Figure 19.

Curtains at sides and back of cabinet are pulled down. Girl asks gentlemen to take their seats at sides of stage. When she says this, it is a signal for you to open secret door. Insert buttonhook in screw eye in special panel and lift it, then do the same with the door. You are now ready to crawl out at the proper signal. Another signal which you may use is to have girl knock on trunk and ask whether you are still there. You answer her knock.

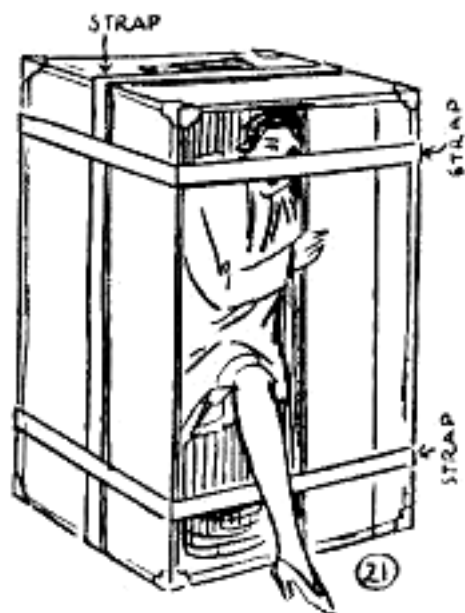


Girl steps into cabinet and draws the two front curtains together so that she is concealed entirely except that her head is still in view.

Figure 20.

As soon as she is concealed by curtain she kicks trunk twice with her foot. This is your cue to come out of trunk. Once outside, quickly remove your coat and come up to girl. She holds curtain with alternate hands as you slip coat first on one arm and then the other. While doing this, she says:

"You are about to see one of the greatest miracles of modern magic. It is an effect that you will never forget. All done in the twinkling of an eye. When I say three - Watch! One - two -three!"



She closes the curtains quickly and hurries around to back of trunk. She gets in through secret door under the strap, quickly pushes door closed and special panel securely into place. She pulls opening of sack over her head and down to her feet so that she can stand on it and conceal opening.

Figure 21.

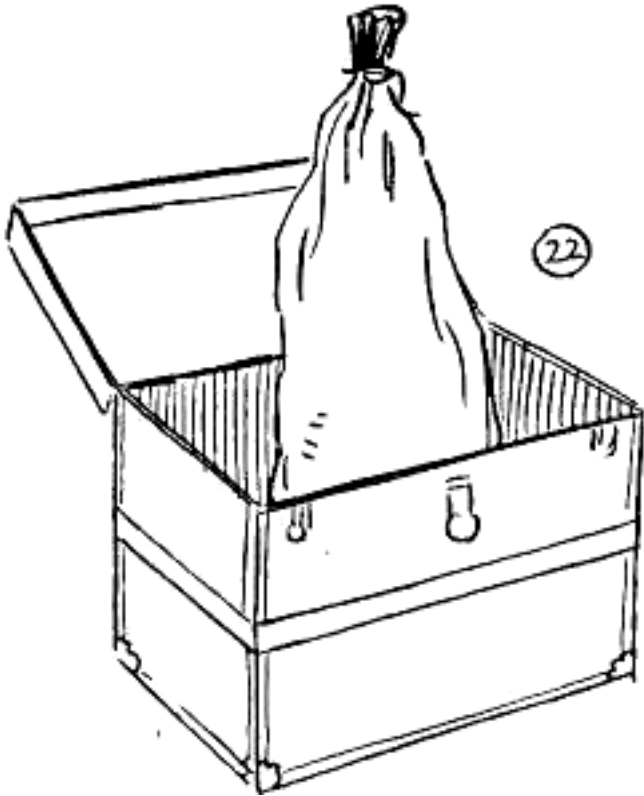
Once inside the sack, girl slips tape on to left and right wrists, binding her hands behind her back.

NOTE: Some performers use two tapes. One is prepared with slipknots for the girl to use. This one is kept in performer's trousers' pocket and then transferred to the gentleman's coat when performer is in the sack. He also has a pair of blunt end scissors in his trousers' pocket. With these he cuts the tape around his

wrists and replaces scissors and puts cut tapes
in his trousers' pocket out of the way.

(53-8)

Now that we have the girl all ready, we can go back to the routine as the audience sees it. The moment girl says "Three!" and disappears, performer sticks his head out of the curtains in the same place that girl's head was. The moment girl is in trunk she gives you a signal, and you throw curtains open suddenly and show trunk. Girl can then continue with her work of closing door and getting into sack, for audience cannot see rear of trunk even with front curtains open.



When all is in readiness, you request that the two gentlemen come forward. Trunk is then pulled out in front of cabinet again and placed in horizontal position. Side and back curtains of cabinet may be thrown up now to show that there is nothing concealed. Straps of trunk are then unbuckled and dropped down. The trunk is unlocked, lid is opened, and girl springs up to standing position. She must be careful to stand on bottom of sack so that opening will not be revealed.

Figure 22.

You quickly untie sack, allowing it to drop down. You assist girl as she hops out of trunk. She shows her hands tied behind her back and you cut the tapes quickly. Remove coat from girl and return it to gentleman, then dismiss both men, and bow to applause of audience.

NOTE: Richard Davis, a well known magician, performs the trunk mystery without an assistant substitution. He has an assistant close the front curtains and he gets out of the trunk quickly and jerks the curtain open to make his appearance. He then tells the audience to watch again. He quickly closes the curtains and gets back into the trunk and sack again. The assistant is used merely to guide the committee and to open and close the curtains. Davis makes of this a sensational illusion.

Some performers have the girl placed in the trunk first and then change places with her. This illusion offers other possibilities also for substitution.

It will be necessary for you to practice getting in and out of the trunk to speed your work. - You are working to create an INSTANTANEOUS EFFECT in the minds of the audience and any hesitation or delayed action will prove ruinous. Every movement must be timed - and remember that speed is essential.

* * * * *

THE CANVAS BOX MYSTERY

This is another effective substitution mystery, similar to the preceding one but less expensive in construction. It may be used as a substitution or an escape.

EFFECT:

Performer shows six wooden frames with canvas tacked on one side of each. These are given for examination. The frames are then fastened together and strapped around the performer

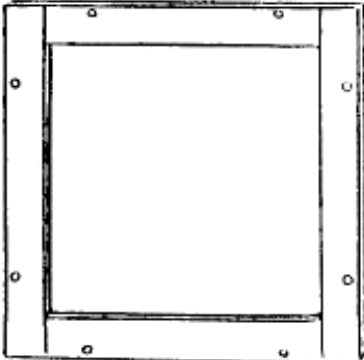
to form a trunk-like box. A curtained cabinet is placed over and around the box and front curtains are closed. Girl assistant steps inside of cabinet. Curtains suddenly open and performer appears. Box is then opened and girl is found inside.

PARAPHERNALIA:

- 1 -- Special Canvas Box, consisting of six covered frames.
- 2 -- Curtained cabinet.
- 3 -- Flashlight, if desired, for use inside of box.

The Canvas Box:

Of the six frames which make this box, two are 26 inches square (these form the top and bottom) - two are 4 feet high and 24 inches wide - and two are 4 feet high and 26 inches wide. The lumber used in the frames is 3 to 3 1/2 inches wide and one inch thick. Sizes may be varied if desired.

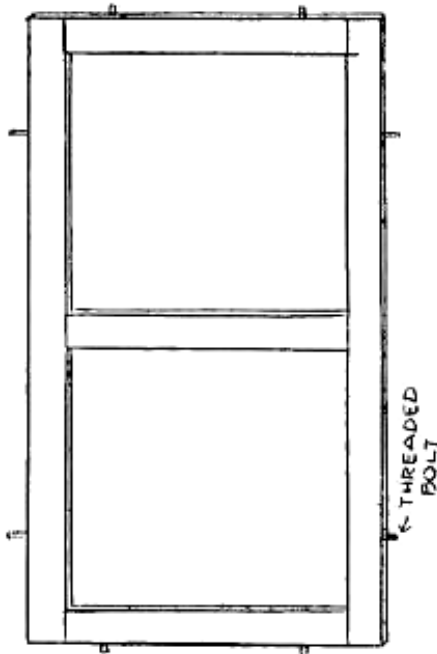


(23)

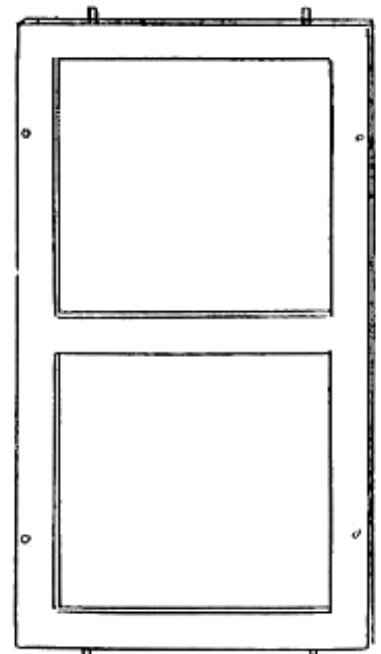
Figure 23 shows construction of top and bottom frames. In each side there are two holes bored for insertion of wooden pegs on side frames.

Figure 24 shows construction of the two frames 4 feet high and 24 inches wide. Top and bottom edges each have two round wooden pegs. The side edges each have two threaded bolts for thumb screws.

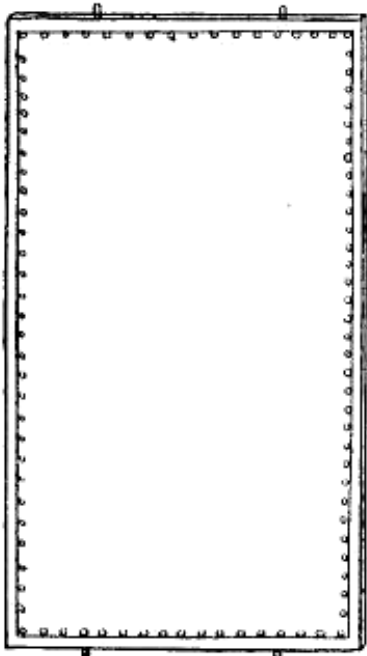
Figure 25 shows construction of the two frames 4 feet high and 26 inches wide. These frames also have wooden pegs at top and holes in the sides through which threaded bolts from other side frames can be placed.



(24)

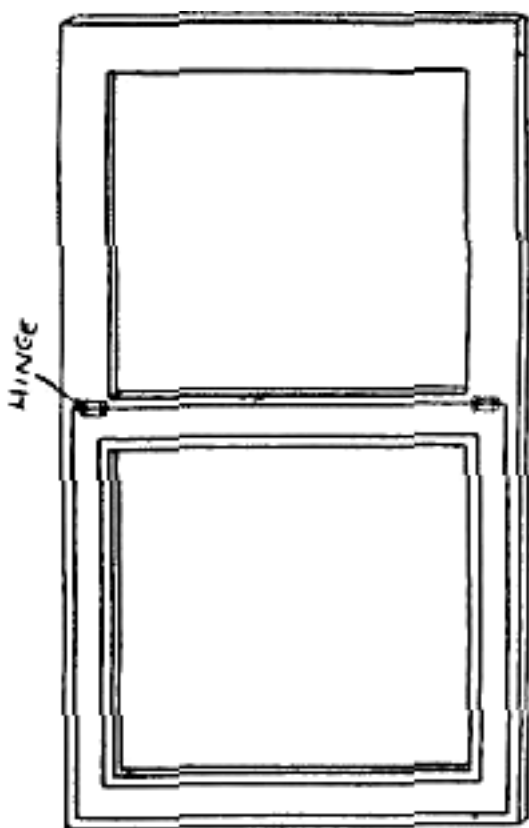


(25)



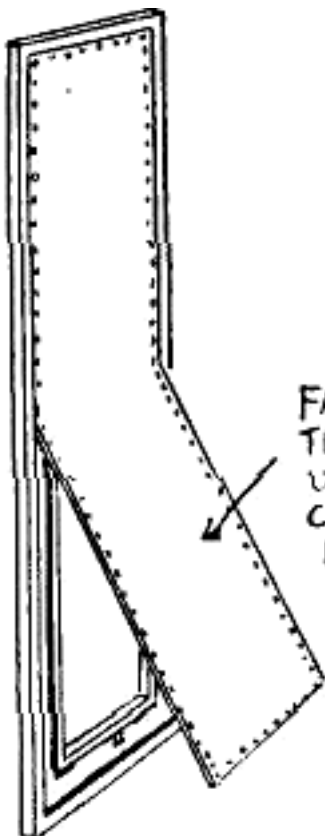
(26)

Figure 26 shows the method in which the frames are covered with canvas. There is a distance of about one inch between the outer edge of canvas and outer edge of the frame. The canvas is securely tacked on with brass headed tacks placed about an inch apart. All the frames are prepared this way except for one of the side frames, 4 feet high and 26 inches wide.



(27)

Figure 27 shows construction of the tricked side frame. A groove about half an inch deep is chiseled out around the bottom and sides of lower half of this frame. Into this groove is fitted another frame. This is about half an inch thick and an inch and a half wide around the edges so that it fits flush with rest of frame. This frame is hinged at the top so that it can act as a door.

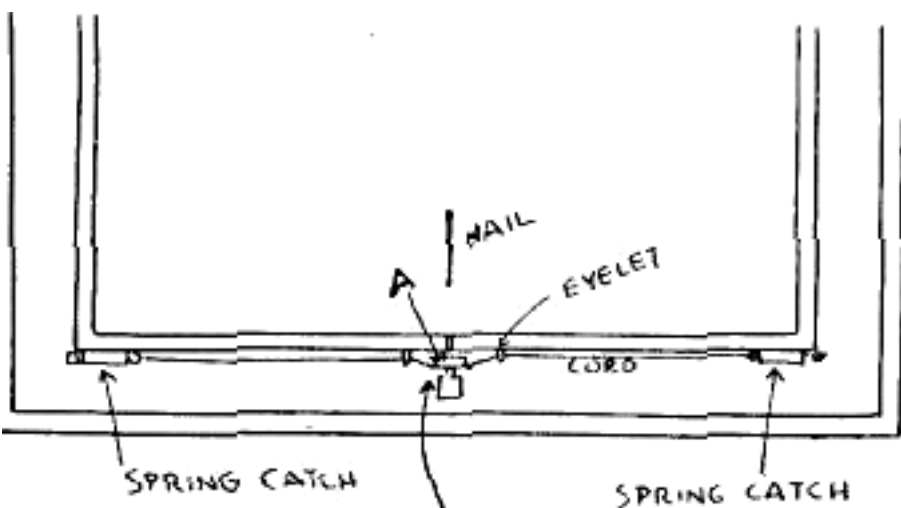


FAKE DOOR
THAT IS RAISED
UP SO PERFORMER
CAN QUICKLY
MAKE HIS ESCAPE

(28)

When canvas is placed over this frame, it is tacked around top half of frame and then brought down over fake lower half and tacked around it. Thus when fake part is in position, frame looks just like the other unprepared frames, but in reality the lower half is free and can swing out.

Figure 28.



METAL PART
TO BE PUSHED
DOWN WITH NAIL
THUS PULLING CORDS AND
RELEASING CATCHES
AT SIDES

(29)

Figure 29 shows method of fastening door frame. To hold the door frame in place, special catches are fixed in the lower groove. By pushing down on A with a nail through a hole in the frame, the spring catches at the sides are forced in and plungers released so that door opens. When door frame is firmly in place and plungers set, frame can be examined closely without danger of detection.

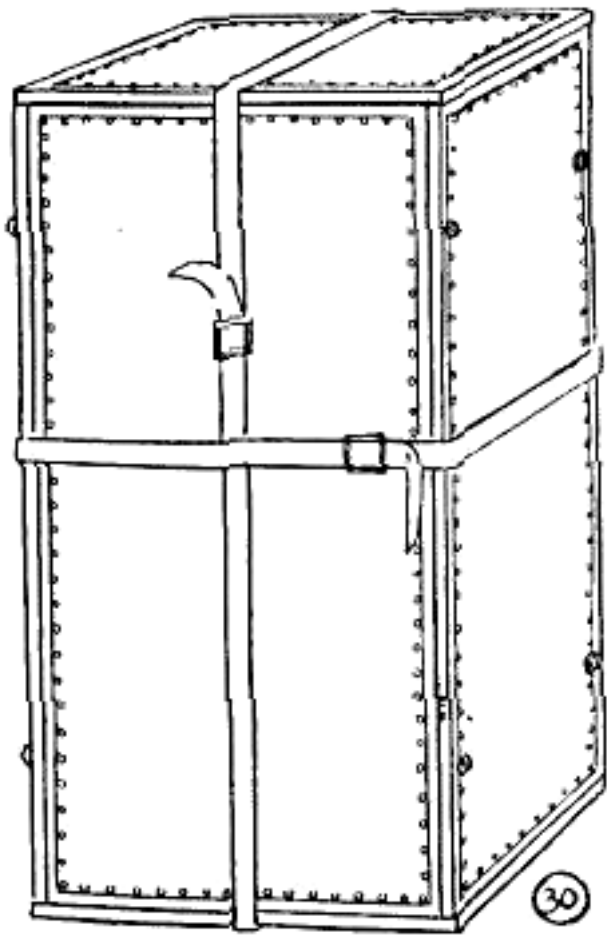


Figure 30 shows the canvas box formed from the six frames. The top and bottom are held to the side frames by the wooden pegs and the side frames are held together by the bolts and thumb screws. Straps are placed around the box but they do not interfere with the door. To make your escape when you are inside of the box, all you have to do is push the nail down through small opening in middle of lower edge of fake frame. This releases the catches and door can be pushed out. If performing only an escape, door should then be pushed back firmly into place and catches will lock it automatically. If a substitution is going to be made, be sure that door is not pushed back and locked until substitution is accomplished.

(53-11)

To Prepare for Performance:

Have the frames stacked together on the stage. Place straps nearby. The curtained cabinet is in center of stage. The cabinet for this illusion must be light enough to lift over box.

SECRET:

To Perform:

Ask two spectators to come up from audience to assist you. Have a chair ready on each side of stage for them to sit on.

"In preparing for the next mystery, it is necessary to have a box built, and for that purpose we will use these six canvas frames. Gentlemen, I want you to examine each of these frames and see that each is merely a wooden frame with canvas tacked over it."

Have the two men step forward. Hand frames to them one at a time, showing both sides and calling attention to their strong construction.

"The pegs, screw parts, and holes are for the purpose of construction. Each frame fits into the other to form a box or trunk. To begin with, we shall place this strap on the floor."

Place strap down about three feet in front of curtained cabinet, laying it parallel with front of stage.

"On this we place the small square frame. Then around me I want you to build a wall with the frames. Place the canvas part outside. On the bottom of each there are pegs to insert in the holes in this frame which I am standing on."

As you say this, place the small frame down over the middle of the strap on floor. Then stand on this frame. Have the two men place the side frames around you. Your assistant shows them how to put the frames in place and gives them thumb screws to place on threaded bolts. She sees to it that fake frame is placed at the rear. When everything is secured to the satisfaction of the two gentlemen, you say:

"Now, when I stoop down into the box, place the top down by pushing the holes in it over the wooden pegs in the side frames. Then for extra security, place the straps around the box. My assistant will direct you in the way to do this."

Stoop down into box so that top frame can be put into place. The strap from bottom is brought up and fastened tight around box. The other strap is then placed around middle of box the opposite way and strapped into place.

Girl assistant then asks gentlemen to help in placing curtained cabinet over canvas box. This accomplished, the side and back curtains of cabinet are lowered into place. The two men are then asked to take seats at each side of the stage.

As the girl assistant says the following she stands in cabinet in front of box and then draws the curtains together in front of her, allowing only her head to remain in view.

"In a few moments you will see a strange feat of magic, performed in the twinkling of an eye. Mr. (your name) has been securely placed inside the box. Each side is firmly fastened to the other with thumb screws and straps. All fastenings are on the outside. A person in that box is held as securely as in a steel-bound box or trunk."

The moment she begins to talk, you push nail into opening of faked frame, open door and make your escape. Allow door to fall quietly into place, but be sure it does not close tight enough to lock. You come up to girl's right side while she is saying:

"When I say -- three -- watch! In a second's time will come a peculiar transformation. Are you ready? One - two - three!"

She disappears, and the moment she does so, you step into her place and put your head out between the curtains.

Girl darts around left side and quickly crawls into box, pulling the door tight so that it locks. She gives you some signal immediately, and you open the curtains wide, showing the canvas box.

Have the two gentlemen come up to help you remove curtained cabinet. Then unstrap the box and remove the thumb screws to release the front frame. Lift off the top and take out the front panel to show the girl inside. Assist her from the box and dismiss the two gentlemen.

NOTE: The Canvas Box Mystery may also be performed with the sack and the hands tied behind the back as in the preceding illusion.

This mystery may be used for just an escape, too. In this case, after you are in the box and concealed by the curtained cabinet, you merely make your escape and then push the door tight so that it will lock. Open the curtain and move the box out of the cabinet. After having the two gentlemen examine it, take the box apart to show that there is nothing concealed inside.

* * * * *

THE PACKING BOX ESCAPE

A packing box escape can be worked into something sensational which will bring you a great deal of publicity.

These escapes vary. Some are legitimate escapes, using a box built by some firm in the city and nailed together by employees of that concern. The more common are magical escapes, using tricked boxes.

Some performers make arrangements with a prominent hardware store, department store, or lumber company in town to use the store's or company's name and have two of their employees nail or lock the performer into the box. Performer tells them that while he ordinarily has the company build the box, he can save them the trouble as he has a box built by some other company for whom he did the escape. Stores are eager to get publicity and are very good about making such arrangements with a performer.

Sometimes a performer will have a legitimate box built by the company according to specifications and then have another duplicate box built himself with the tricked panel, about which the company knows nothing. The store-built box is exhibited in front of the theater or in the store window and is delivered to your place of performance early in the evening. You merely substitute your tricked box for your performance. Or you can even have your tricked box exhibited in store window, in front of your theater, or in the window of the newspaper office without fear of being detected.

It is a good idea to try to get the store to mention in their advertising the fact that they had challenged you to escape from one of their packing boxes. The packing box escape is also a good ballyhoo stunt out in front of the newspaper office or some prominent place where a crowd will gather. Perhaps the store that has challenged you will permit you to ballyhoo in front of it.

The big idea of a packing box escape is to get a great deal of publicity -- to set the town talking about you. The crowd will come out to see you with the expectancy that you might not get out. Though they hope you do, they want to be on hand in case anything happens. Try to reach everybody in that town with your publicity.

EFFECT:

A packing case built of wood is shown and examined freely by a committee from the audience. Performer steps into the box and the lid is nailed down over him. If the lid is hinged on, it may be padlocked instead of nailed. Ropes are then bound around and around the box. Box is placed in a curtained cabinet and the curtains are drawn. Within a short time, the curtains are suddenly opened and there stands the performer. The box is brought out and given for examination. It is then opened and gives no clue as to method of performer's escape.

PARAPHERNALIA:

- 1 -- Special Packing Case.
- 2 -- Curtained Cabinet.
- 3 -- Pocket flashlight, screw driver, and two short screws in pocket.
- 4 -- Hammer and fairly large nails and an axe.

The Packing Case:

Figure 31 shows the packing case without the lid. The cleats on the inside and outside of the ends of the box seem

to be there to reinforce the box, but in reality they are there to cover magical preparation of the panels of one of the ends. These two boards are apparently nailed securely, but the nails are short and do not go beyond the cleats themselves. The dimensions of the box are 38 inches long, 23 1/2 inches wide, and 25 inches deep.

Figure 32 shows the lid of the case. It is made of straight boards with two reinforcing cross bars.

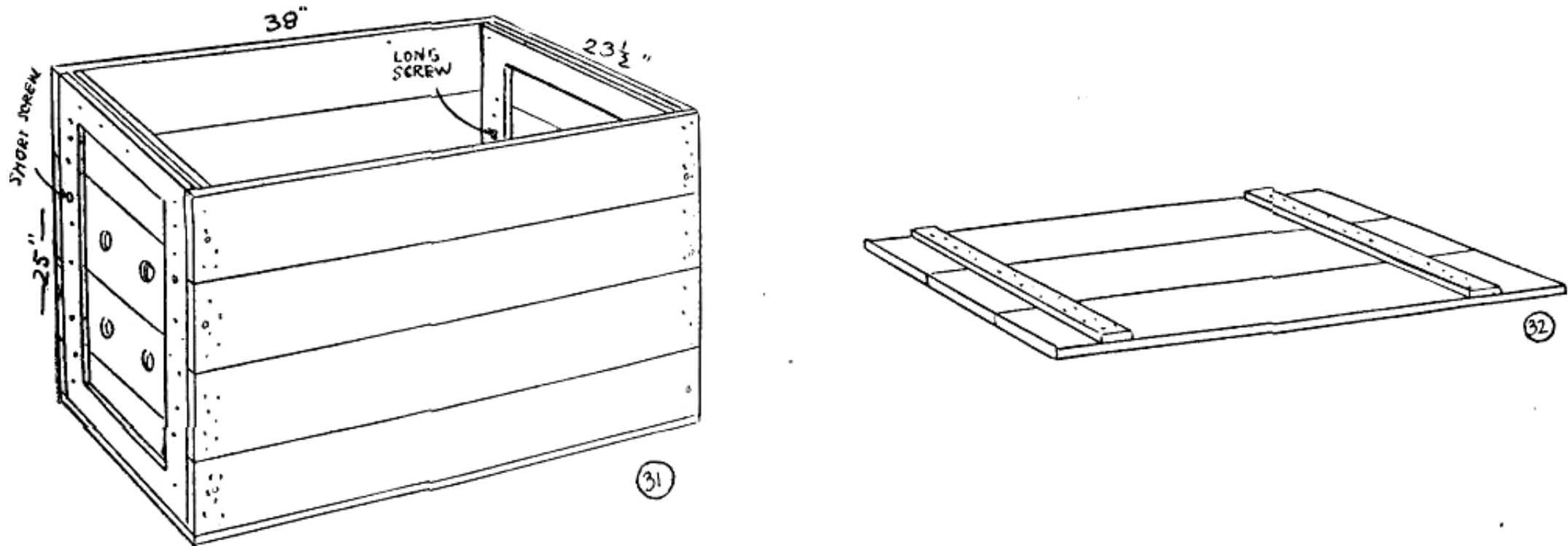
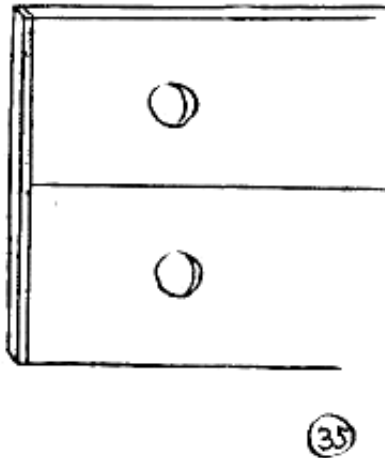
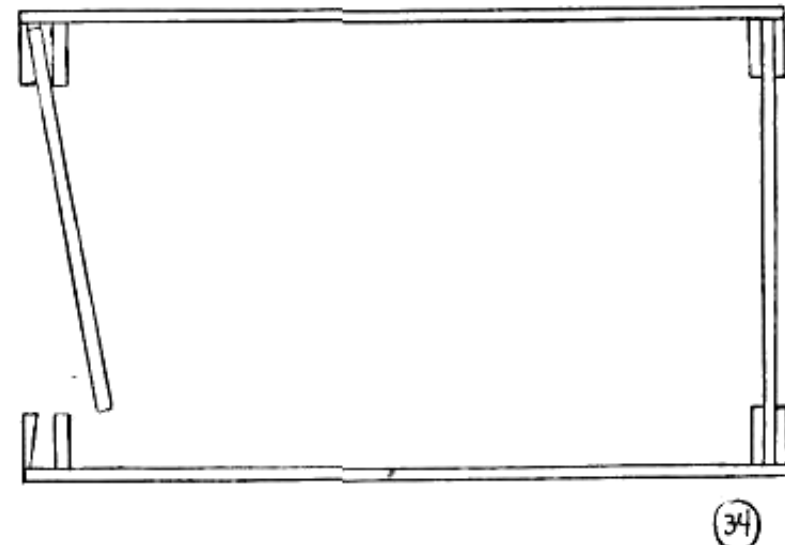
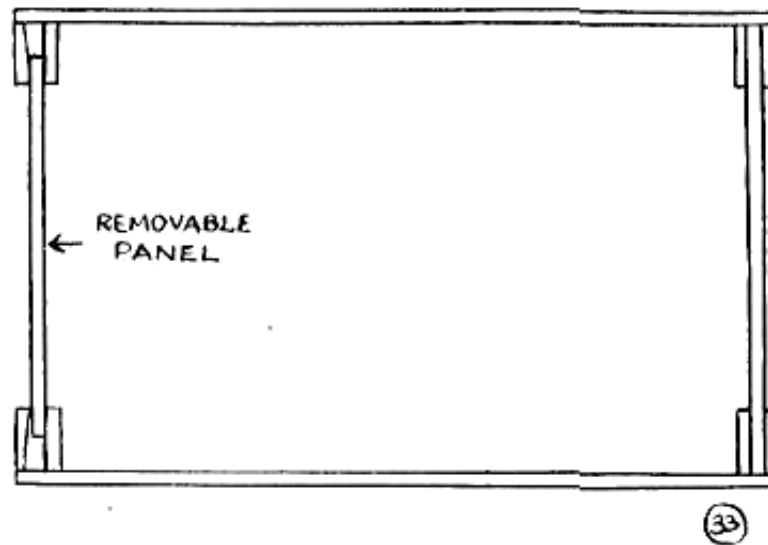


Figure 33 is a diagram of the bottom of the box. One end of box is secured by cleats inside and outside. Cleats at the other end are narrowed down toward front and back of box. This end of box is made of a short, removable panel which just fits between cleats on one side and those on the other.

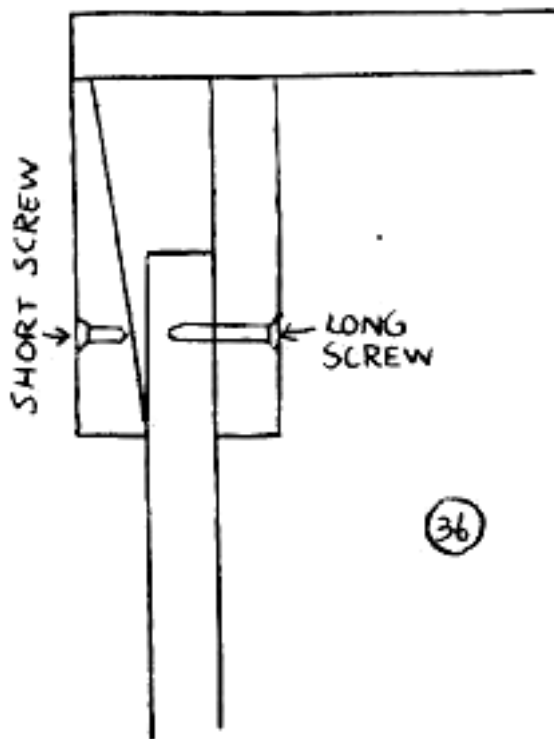
Figure 34 shows the way the panel is removed. It is slid back further between the cleats on one side, thus releasing the other end, and then it is withdrawn entirely from the box.



The two boards which make the removable panel are usually fastened together with nails or cleats at the sides so that they can be handled as one piece. Air holes are made in the panels at both ends, not only for air, but also for a means of gripping the removable panel to take it out.

Figure 35.

Figure 36 is a diagram, showing the way in which the removable panel is held in place between the cleats. On the



inside of the box there is a long screw at each end which goes through the cleat into the fake panel. On the outside of the box there is a short screw at each end. This is merely for effect as it does not enter the fake panel at all.

Other screws are placed here and there on the box to give impression that screws as well as nails are used in the construction of the box.

The box with this arrangement can be handled roughly, kicked, and pounded, and examined freely without danger of detection.

SECRET:

To Make Escape:

You have a screw driver concealed on your person. When you are in the box, unscrew the two long screws holding the fake panel and remove them. Get your fingers in the air holes of panel and push it to one side. This frees the opposite end of the panel and you can now remove the whole panel easily. Screw the two short screws which you have in your pocket into the cleats where the long screws were.

Get out of box. Remove the two short screws on outside of box. Replace the panel between the cleats, with inside of panel now facing out, and screw in the long screws to replace the short ones just removed from outside. The panel is once again held securely in place, but this time the screws holding it are outside. To the observer, however, the reversing of the screws is not noticeable and the box looks the same after the escape as it did before.

To Perform:

Have a committee of about four people come up from audience to examine the packing box. If this illusion is performed as a publicity stunt, have two men from the store come up to nail you in.

Show the box on all sides -- kick, thump, and hammer it, and have the committee do likewise. More nails may be driven into it, providing they do not affect the trick panel. This is not necessary, however.

"Ladies and gentlemen, this packing case was especially built by (name of company), and they have issued the challenge to me to escape from it. Their own men are to nail it up, and for extra precaution they will tie it with ropes. They can spike it, or do whatever they please. I shall prepare myself to go inside."

Remove your coat and vest and roll up your shirt sleeves. When Houdini performed this illusion, he wore a white shirt with a soft collar open at the neck.

Look over case a little, then step inside.

"The escape I am about to attempt is extremely difficult. Because I have been successful in making similar escapes is no reason why I will be successful with this one. There is always a chance to slip. However, I trust that there will be no slip and that I will come out as I always have. I have had air holes made in the box to give me some air, but even then air conditions are not of the best. My assistant here keeps watch over me and should I not appear within a given time, he is to smash in the box with an axe -- or if I signal him, he will smash the box. I do this as an extra precaution, for escapes of this nature are more or less dangerous."

An audience likes to watch dangerous things so that you can work on that side of it.

"All right, gentlemen, put on the lid and nail me in. Then rope the box -- and here's hoping."



You crouch down in box, and the lid is nailed on as the assistant directs. If regular shipping clerks nail the box, it will prove interesting to see how quickly and expertly they nail the box. When box is nailed, ropes are tied around it both ways.

Figure 37.

Box is then pulled into curtained cabinet or cabinet is placed over box. Curtains on both sides and rear are dropped down and front curtains pulled across to screen case. Your assistant holds curtain closed and holds his watch in his hand, apparently for emergency. He says, "All right, go!"

In the meantime, while the lid is being nailed on the box, you gain time by unscrewing the long screws and substituting the short screws for them. Air holes may give you enough light, but if they don't, a quick flash from your flashlight will locate the screws for you.

When assistant says "Go!" you remove the fake panel and crawl out of the box. Replace the panel, remove the outer short screws and substitute the long ones for them, thus securing the panel in place again. Put screw driver and two extra short screws in your pocket.

Pull open the curtain suddenly and puff as though you had gone through considerable effort. Take a bow.

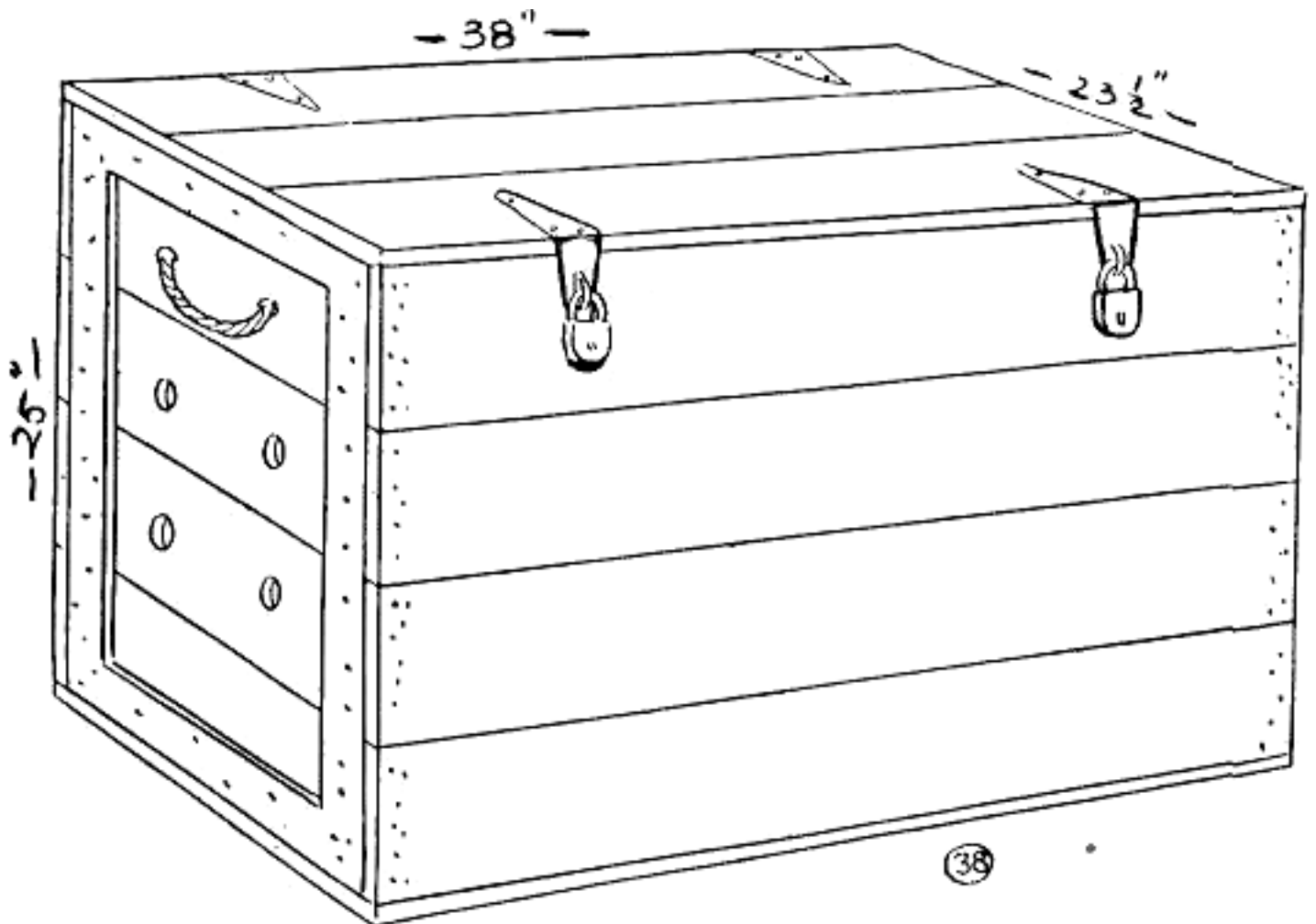
Have committee come forward and examine the box on the outside. Then have them smash in the lid with the axe and see that the box is empty. Dismiss the committee.

NOTE: A popular type of packing case which can be used over and over again is one in which the lid is hinged on and

has clasps in front which can be padlocked. This case may be used as a trunk to carry paraphernalia, and yet it is ready at a moment's notice for the packing case escape. If you use this case, the lid, of course, is not smashed in at the end. The case is unlocked and opened to show it empty. Our illusion builder supplies this case with hinged lid unless otherwise specified.

(53-17)

Figure 38.



THE PACKING BOX ESCAPE PERMITS OF A GREAT DEAL OF SHOWMANSHIP, AND YOU CAN WORK IT UP INTO A SENSATION. IF IT IS STAGED RIGHT, YOUR AUDIENCE WILL BE AT A HIGH PITCH.

* * * * *

THE PAPER BAG ESCAPE

This is an odd escape and effective because of the fragile material used.

EFFECT:

A large paper bag is shown - large enough to hold performer. It is turned over on the floor and performer crawls into it, feet foremost. Bag is placed upright again with performer standing in it. Spectators tie the top with tape. A curtained cabinet is then placed around the bag and the curtains are closed. In a short time, performer steps out of the curtains. The bag is shown still to be tied up and examination of the bag reveals no clue as to the method of escape.

PARAPHERNALIA:

- 1 -- Paper Bag, large enough to hold performer.
- 2 -- Two pieces of quarter-inch tape to tie top of bag.
- 3 -- Curtained cabinet.
- 4 -- A razor or small pair of sharp scissors.
- 5 -- Pocket flashlight.

SECRET:

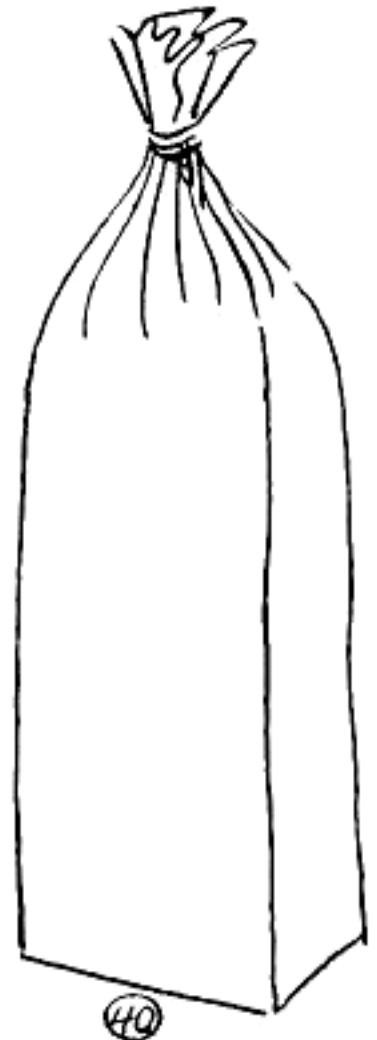
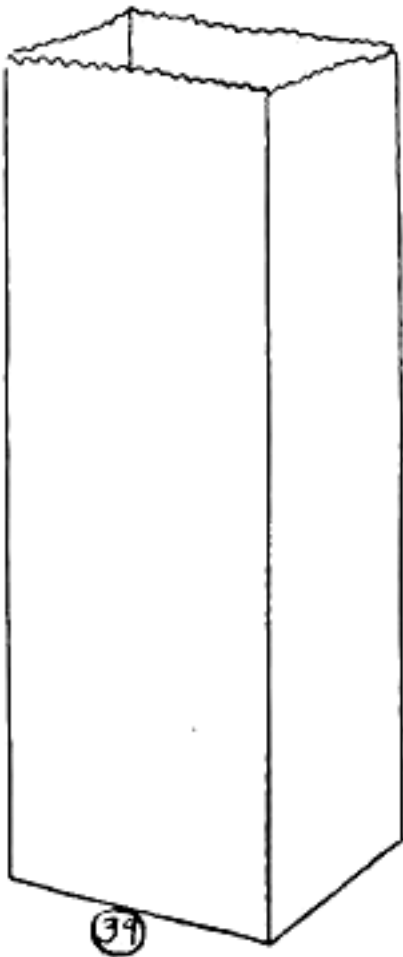
To Prepare:

The Paper Bag:

Make this bag of strong Manila wrapping paper. Make the bottom square and have the bag large enough so that you

can stand up in it and still have enough paper to tie above your head. Just glue the paper together to make the bag.

Figures 39 and 40.



Conceal the razor or scissors on your person, also one of the pieces of tape. Curtained cabinet is set up and second piece of tape is nearby.

To Perform:

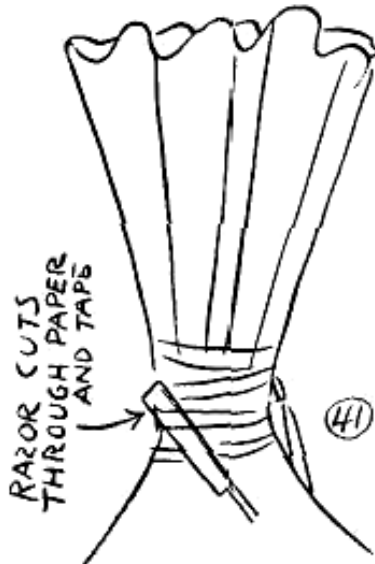
Have committee come up on the stage - two men are enough.

"I am going to attempt a most peculiar and difficult escape -- that is an escape from a paper bag. Some of you might imagine that by using paper it would be easy to escape. All you have to do is tear a hole in it and crawl through, but, of course, that would destroy the bag, and I must escape without harming the bag in any way. I am going to be tied up in the bag. I must work quickly for, as you know, paper excludes air and breathing would be difficult for any length of time. First of all, gentlemen, since you are acting as chief investigators, I want you to examine this paper bag carefully. Look at the sides and bottom. You will see that it is just made of paper firmly glued together. Also examine this piece of tape with which you are soon to bind the top of the bag."

After bag has been thoroughly examined, tip it down on the floor. Step into opening and then push bottom of bag down on floor so that bag will be upright and you can stand inside of it.

Have assistant help you get into bag. Then assistant requests that one of the gentlemen tie the tape securely around the top of the bag, enclosing you in it. This done, the curtained cabinet is placed over and around the paper bag and the curtains are closed all around.

When assistant gives you the signal, you take razor or scissors and reach up into neck of the bag. Cut a small slit through the bag, and then through the tape around neck of bag.



Reach up with hands and spread top of bag open. The tape comes off. Now manipulate the bag down on to the floor so that you can crawl out of it. Pocket the cut tape, put the bag upright again, and with piece of tape from your pocket tie it up again. From the piece of cut tape you can see how the tape was knotted originally and you can duplicate the knot.

Open curtain suddenly and bring the bag out for hurried examination. Quickly remove tape and open up the bag to show it empty.

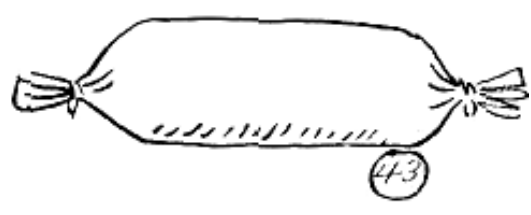
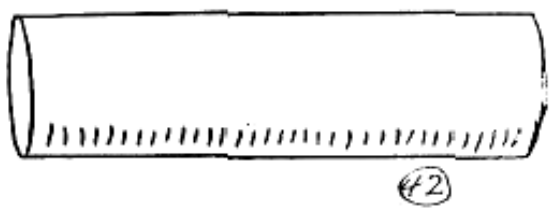
NOTE: This escape may be accomplished with the use of a bag about 4 feet high. In this case, you crouch down in the bag.

* * * * *

THE BONBON PAPER BAG ESCAPE

This is similar to the regular paper bag escape except that in this effect, a large tube of paper is used to enclose the performer and both ends of tube are tied with tape. It has the appearance of a large candy kiss or bonbon.

Figures 42 and 43.



The escape is made by cutting through the paper and tape at one end of the tube and crawling out of it. This end is then retaped as it was originally. In this illusion, you crawl into tube, feet foremost, and remain in horizontal position.

Harlan Tarbell

TARBELL SYSTEM, INCORPORATED, Chicago.

* * * * *

LESSON 54

This lesson brings you more fascinating illusion work.

* * * * *

THE BLACK ART TABLE

And now we come to one of the most interesting and most important developments in Magic – the development of "The Black Art Table". This is a splendid revelation of how a new thought will usher in a new era in Magic.

In the early days the magician came to the conclusion that a table could be used to make articles vanish or appear, or for substituting one thing for another. To aid his work, that is, to help conceal his apparatus and assistant, he draped his table to the floor. In the top of the table he placed trap doors. Under the table he had his concealed assistant operate the traps and appear, disappear or change articles on the table at will. If the performer wished to make an orange disappear, he had but to cover the orange with say a metal cone, signal his assistant and cause the orange to disappear under the table.

Then as time went by another magician said to himself why not do away with the long draped tables and concealed assistants. Traps could be used successfully with shorter drops and by having a cloth bag beneath each trap to catch the object dropped through the trap. So magic took a new turn and the stage settings took on a new appearance. The work of the assistant under the table was substituted by mechanical contrivances under the table top. Clever mechanical contrivances were brought into being to make an object appear, disappear or change. And it does not seem so long ago, either, that wrist traps, changing traps, etc., held their due place in the magical dealer's catalogue.

Robert Houdin in his theatre in Paris used to make good use of traps in his center and side tables. I have been in his theatre long after he was dead and gone, but have seen the same tables that he used. A modern magician was performing while I was there. He used side tables fastened to the side walls and it was an easy matter to drop an article through a trap and have it slide back to the assistant behind the scenes waiting to receive it.

Then along came a bright genius who said: "Why have traps in a table?" Why not just have holes with cloth bags inserted and disguise the holes. And it was by this reasoning that this genius developed the famous "Black Art Table Top". The top has holes of various sizes here and there with a cloth bag under each to catch any object dropped therein. The hole plus the pocket is called a "well". The

top is covered with black cloth such as black velvet, and the pockets are black and of similar material. Around the edge of wells bright colored braid such as gold or white is fastened. The braid in turn is evolved into some design on the table. The contrast between the black top and bright trimming confuses the eye and the hole in the table at a slight distance away has the same appearance as the top. Magicians have concealed black art wells ingeniously with clever designs. The wells may be round or square, rectangular, octagonal or triangular. The round well used to be preferred. Then came a rage for the square ones, perhaps with the illusionary idea that holes were usually thought of as round and the square was not commonly associated with them. But regardless of shape the black art well was well received in magic and the black art table became a prominent and essential part of the professional magician's equipment. The black art well is a good magic adjunct, as tables are not associated in the popular mind with having holes in them. Tables are in common use and have a flat, level surface.

MY "SOCIETY SPECIAL" TABLE

The style of table I use came about somewhat from necessity because in playing to society my object was to crowd as much into small space as possible, having it as light as possible, yet rigid and strong, have it attractive in appearance, yet contain three noiseless black art wells, a special slot in the rear of table top for concealing extra cards, also a special servante if needed. My "Society Special" weighs only about four pounds, and is easily slipped into a suitcase. It can be set up or taken down quickly. A pair of tables adds to the stage settings.

I have had many kinds of tables, heavy and light ones. Some were like lugging around anvils. Others were light but they wiggled and wobbled, necessitating keeping one eye on a trick and the other on the table to see that it wouldn't tip over.

I shall never forget my first black art table. I was so proud of it. During my performance I was to make a glass vanish. So under cover of a piece of paper I dropped it into a well. When it reached the bottom of the pocket in the well, it jarred the table, which came down with a thud very perceptible even to the audience. The table top was an excellent sounding board. It was truly a noisy table, and seemed to be anxious to notify the audience that something had happened.

But with the "Society Special" I can go about my work without any worry of jarring sounds or wobbles. It is as easy to vanish a glass as a paper wad. I have a good flange that attaches tightly to the upright part of stand and the bottom has a wide spread and touches the floor in three places only, which adapts it to uneven floors.

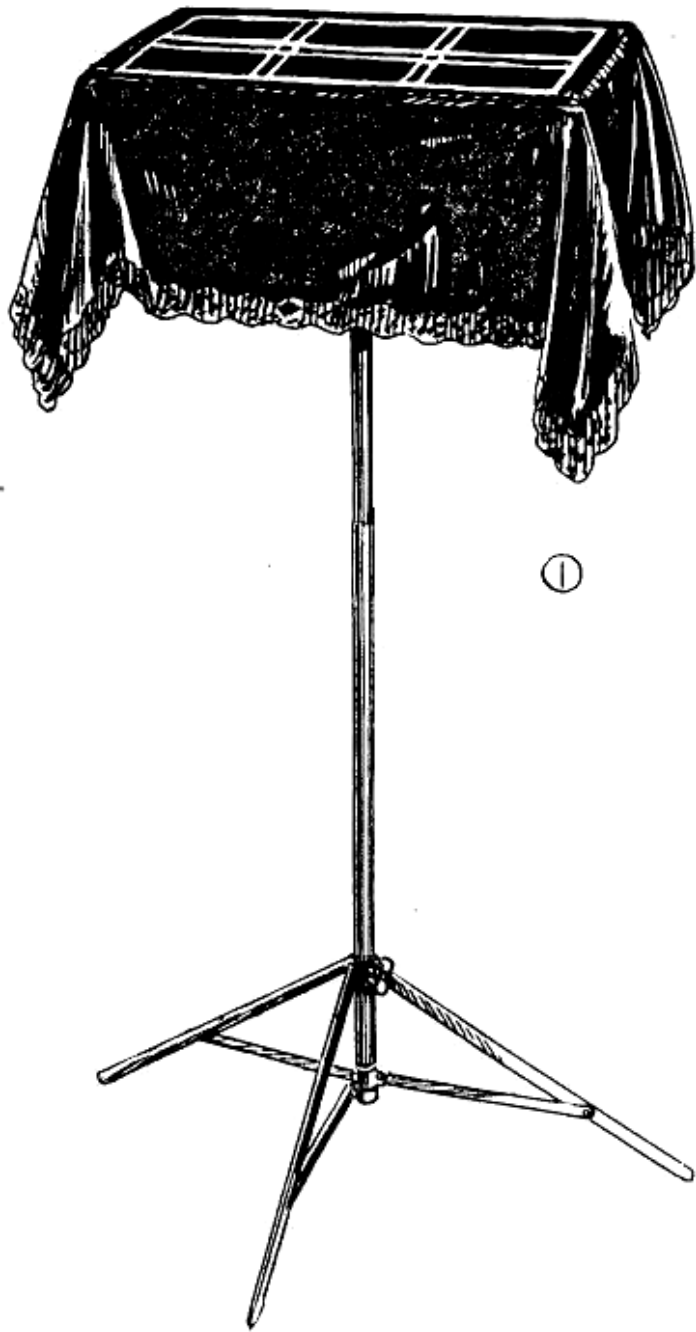
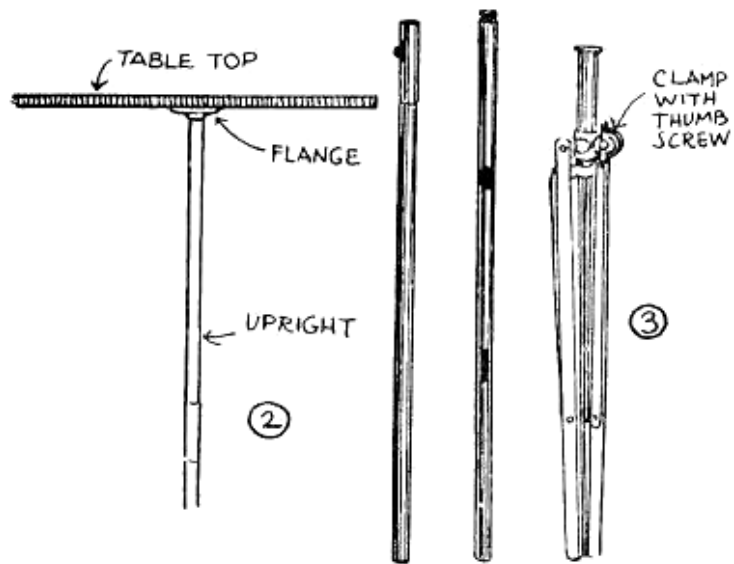
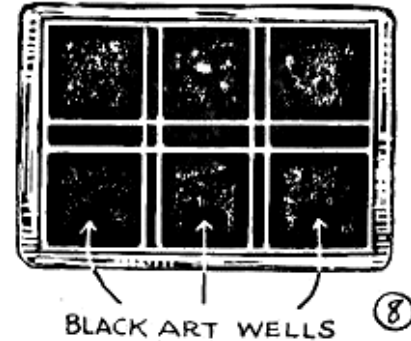
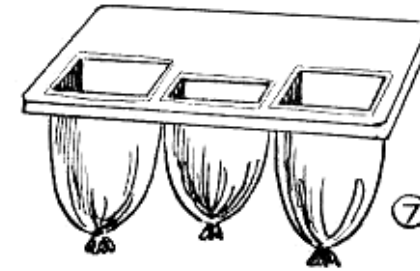
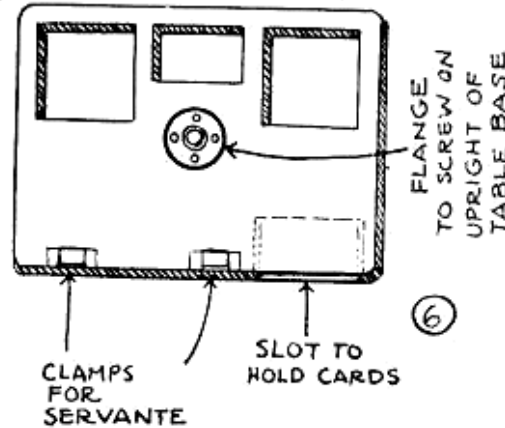
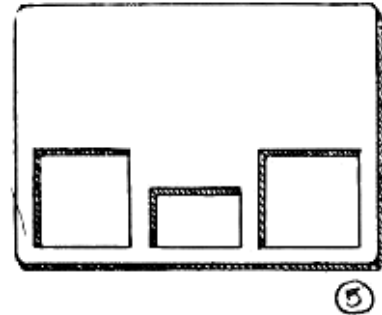


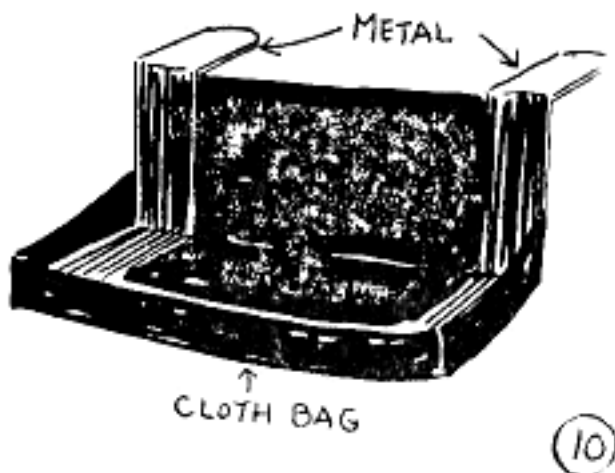
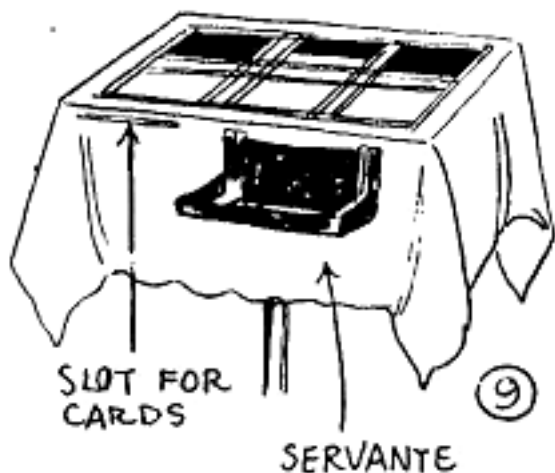
Fig. 1 gives you an idea of the appearance of the table. It is impossible to do justice to it with a pen and ink drawing to show the attractiveness of the nickeled stand, the velour trimmed with braid, and the black velvet top trimmed with gold braid. The drape in shape is just the same that table would have if a square piece of cloth were laid over it.



The table top is 10 x 14 inches. Attached to its center is a brass flange which screws onto the nicked upright of the base, Fig. 2. The table base itself comes apart into three pieces for packing Fig. 3. The upright rod is made up of two pieces. The three legs fold together. The upright is held secure by a screw clamp.



The top also folds into small spaces by folding drape down over the top, Fig. 4. The top itself is of three-ply lumber. In the front half three wells are cut, Fig. 5. The flange is screwed to center of table and on rear of table two metal clamps are fastened to hold detachable servante. Also a slot cut in edge of table large enough to hold a few playing cards so that cards stick out about three-eighths of an inch, Fig. 6. The wells are then lined with black cloth. Sort of square pockets with no bottoms. The bottom is formed by tying the cloth shut with a piece of string. In this way the depth of the pocket can be regulated, Fig. 7. Sometimes rubber pockets are used for certain places where liquids are used. The table is then draped with the velour cover, say a green shade and spaces cut out for wells. The velour is then securely fastened, and a piece of black velvet is placed on top with space also cut out for wells. Then gold braid is tacked down in a pattern as shown in Fig. 8. The braid comes around the edge of the wells. The center well lacks a braid on the rear side but this is camouflaged by braid further back.

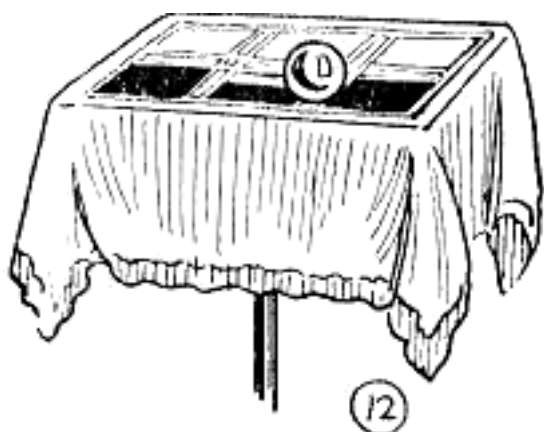


When a servante is needed, a folding one is attached as in Fig. 9. It consists of two pieces of metal to which is sewed a black cloth, Fig. 10. It folds up similar to Fig. 11 for packing.



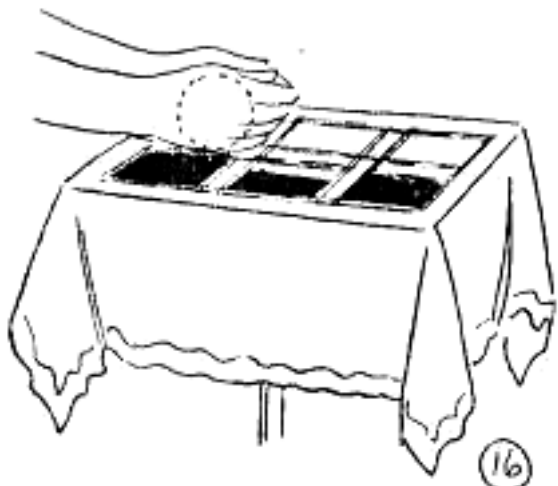
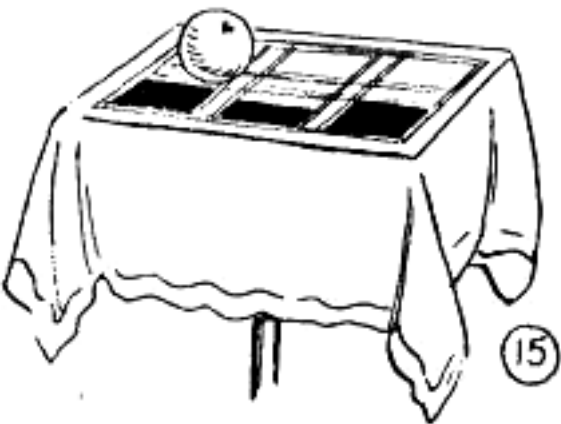
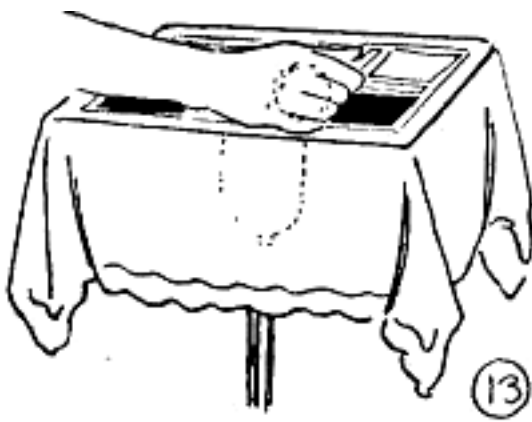
HOW TO OPERATE
BLACK ART WELLS

In my "Society Special" table the black art wells are near the front instead of being at the rear as was the general position before. This makes it much more convenient for performances requiring the picking up of articles from wells. Donald Holmes in his excellent book, "The Magic Art", has shown some excellent moves through the use of front wells. However, if desired, table top can be turned around, changing the wells to rear.



TO "VANISH" A
BILLIARD BALL OR
SIMILAR SMALL
OBJECT:

Place ball on table similar to Fig. 12 near well. The braid helps to hold it in position. Pretend to pick up ball. Close hand over it, Fig. 13, which screens ball from view of spectators. Move hand with ball slightly backwards

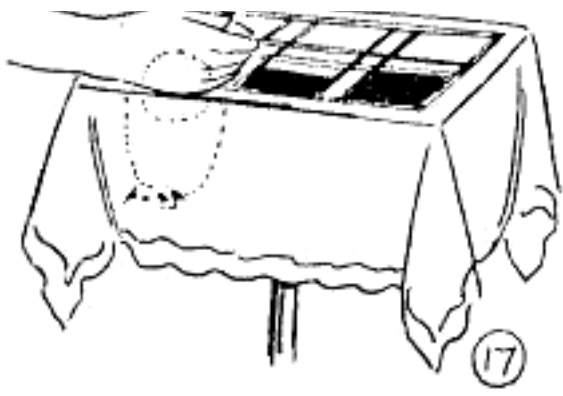


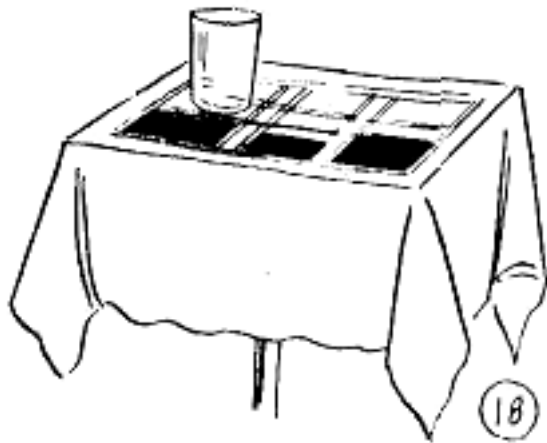
so that ball falls into middle well. The hand is held close to table of course. Close hand as though containing the ball lifting hand from table, Fig. 14. Then bring this hand forward, at the same time opening hand slowly. Show to the audience. The impression naturally follows that you have vanished the ball.

Sometimes I have worked a puzzling effect by apparently placing ball in a small paper bag, then screwing top of bag together, I crush bag between my hands and with a bang toss it to audience. Spectators would swear they saw me place ball in bag as they took it for granted I lifted it up from table.

TO "VANISH" AN ORANGE OR LARGER ARTICLE:

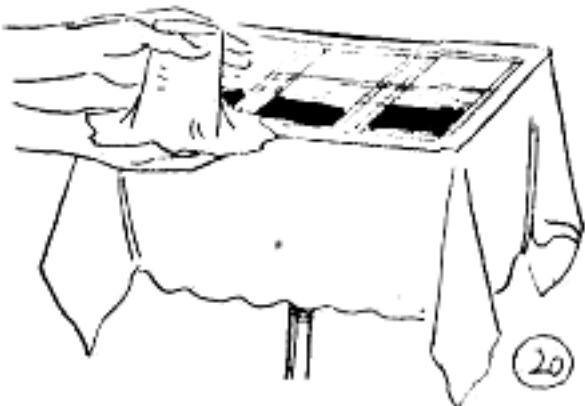
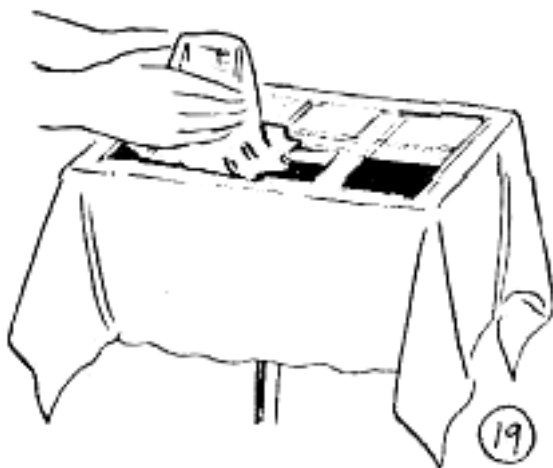
Some objects are too large to screen with one hand, so two hands are used. Place orange on table similar to Fig. 15. Bring hands down so both hands clasp orange, Fig. 16, one in front and the other behind. Bring hands over black art well, allowing orange to drop into well, Fig. 17. Move hands forward as though containing the orange. Move away from table and "vanish" orange from hands in a graceful manner.





TO "VANISH" A GLASS TUMBLER:

A glass tumbler can be "vanished" in a similar manner to an orange by screening well with hands. You can "vanish" a glass nicely with even one hand. A pretty "vanish" of a glass is performed by aid of a square of tissue. Glass is placed near well as in Fig. 18. The square of opaque tissue is brought over and around the glass, Fig. 19. The paper is formed around the glass. The glass is brought over well and allowed to drop therein. The paper still retains the form however as though having a glass beneath it. The left hand holds paper form while right hand goes to front edge of table and form is slid off table, Fig. 20. The right hand apparently holds glass up within paper to keep it from falling. Now step from table and face audience suddenly bringing the left hand down on the right, apparently "vanishing" glass in hands. A nice finish here is to roll up paper into a ball and toss to audience. A glass of water (say, half-full) can be "vanished" in similar manner. For safety have rubber lining in pocket or around pocket. Rubber lining need not extend to top but instead be out of range of spectator's vision.



Many magicians "vanish" glass by covering with handkerchief and then tossing the handkerchief into the air, spreading it out to show that glass has vanished. The handkerchief is doubled with a round cardboard or celluloid disc sewed in center the same size as top of glass. In covering glass with handkerchief the disc in center of handkerchief is placed on top of glass. The disc is held with fingers. The glass is dropped into well and hand carries disc upwards with handkerchief draped down therefrom. The illusion is that glass is seen under handkerchief. Handkerchief is thrown into air and "vanish" is easy.

The black art well can be readily used to vanish a small object in the art of picking up your wand which has been lying on the table near the black art well.

TO INDETECTABLY CHANGE ONE GLASS FOR ANOTHER:

This same principle can also be used for changing other objects. It is effective for placing certain borrowed objects in a glass then covering with a handkerchief and upon removing handkerchief the objects have vanished from glass.

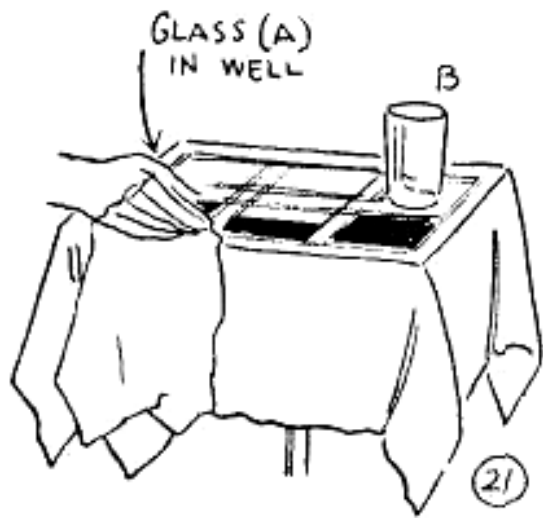
Place one glass on table in back of the left hand well. In the right hand well place a duplicate glass, Fig. 21. The left hand pocket should be just deep enough so that glass does not sink too far down and can be easily grasped at the right psychological moment.

The object is to apparently wrap the visible glass standing on table in a handkerchief, yet in reality you have another glass in the

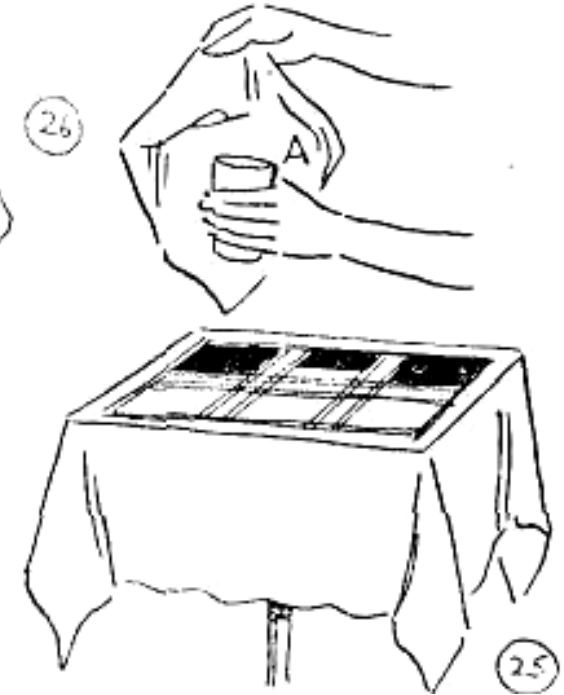
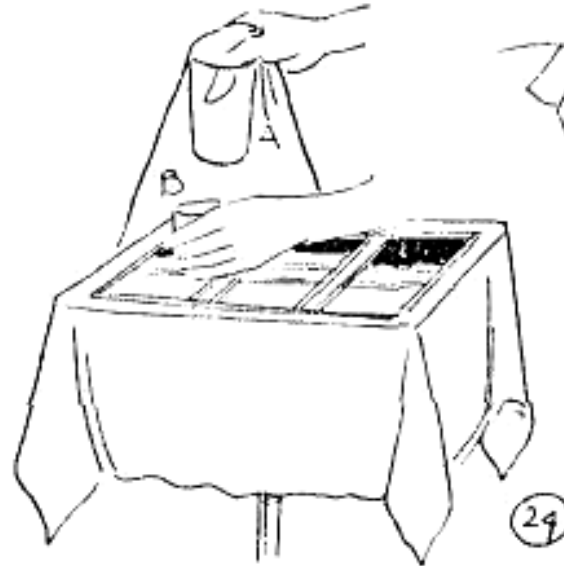
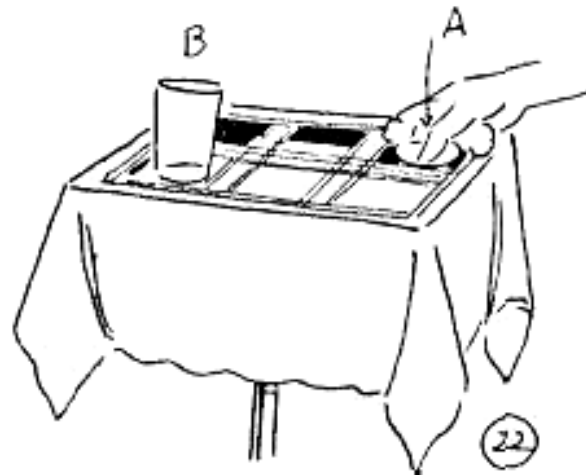
handkerchief instead.

Let A represent glass in well and B the glass on table.

(54-5)



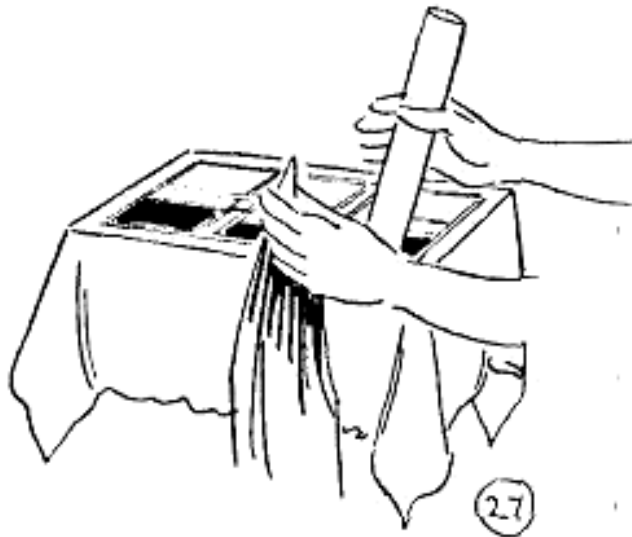
Call attention to Glass B on the table with left hand. In your right hand you hold a handkerchief with enough of one corner tucked into right palm to allow handkerchief enough spread to cover enough space to screen a glass from audience. Bring right hand with handkerchief to front edge of table, Fig. 21, and grasp Glass A in well with thumb and first finger. Fig. 22 shows rear view. Pick up Glass A, Fig. 23, while the left hand picks up Glass B from the table. The attention of the audience is centered on the left hand and Glass B. Pretend to place B under handkerchief. What you really do is to screen B with the handkerchief long enough to drop it gently into the black art well, Fig. 24. Then raise empty left hand and grasp Glass A, Fig. 25. Cover A with handkerchief, Fig. 26.



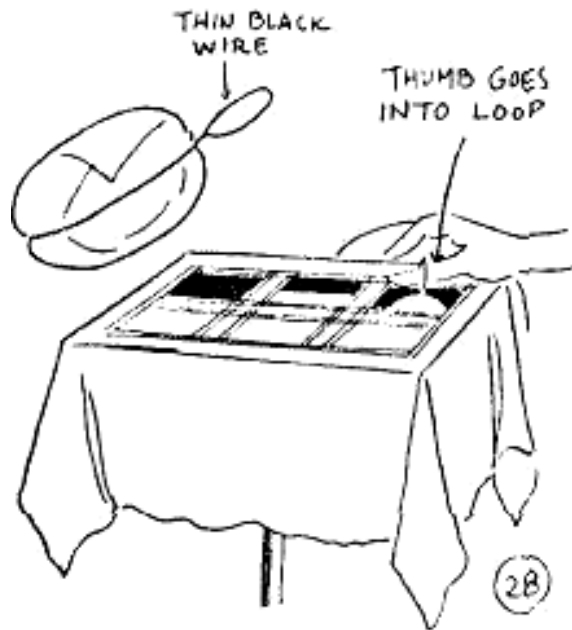
If you have performed these moves without hesitation and screened well with handkerchief the illusion of picking up glass from table and placing in handkerchief is excellent.

This form of exchange is a handy "exchange" for using any number of ways; for example, substituting a glass containing a silk or full of rice for a glass of water, milk or what not. From the audience's standpoint the glass does not change, but only the contents.

THE COLOR CHANGING SILKS:



In getting rid of the tube in the color change of silks in a paper tube the black art well is useful. Fig. 27 shows how paper tube is brought over black art well and metal tube allowed to slide out of paper and into well as left hand places handkerchief on table.



HAT PRODUCTIONS:

The black art well is useful to hold the load of a hat production. For example, a bunch of silks are carefully wrapped into a secure bundle and tied around with thin black millinery or jeweler's wire, Fig. 28, leaving a loop with wire large enough to easily slip thumb through. The load of silks is placed in one of the wells out of audience's sight. The loop of fine wire extends upwards so that thumb can be easily slipped into same, Fig. 28. To load a hat all that is necessary is to hold hat in right hand with opening away from audience. As left hand places something on table, the right hand comes to front of table, Fig. 28, the thumb is slipped into the wire loop and hand raised. The hat screens the movement and silks are easily brought up into the hat, Fig. 29.

(54-6)



Remove wire from silks and produce them from hat.

I could write a whole series of magic lessons on effects employing the use of the black art wells for the possibilities are almost unlimited.

THE CARD SLOT

This is the special slot cut in the back of the table. It is useful in adding extra cards in the rising card trick, four ace tricks, etc. The extra cards are slipped into the slot as in Fig. 30. To get extra cards onto deck merely place deck down on table over extra cards, Fig. 31. Deck can rest there a moment while you show something else. Pick up deck together with the extra cards, Fig. 31. Fingers rest on one end of deck and the thumb on the other end. In this manner cards are easily picked up.

THE TREASURE CHEST

And now I am going to tell you about the "Treasure Chest" illusion. In this case I have developed a new adaptation of an old time principle and utilization of the famous old tip over box.

EFFECT:

A wooden chest painted like a treasure chest is freely shown all sides and placed on the table. The chest is tipped over so that lid faces audience. The lid is raised and box shown empty. The lid is closed and box placed in upright position again. Lid is raised and various articles are removed such as silks, lanterns, etc., or it may be utilized for a dove or rabbit production.

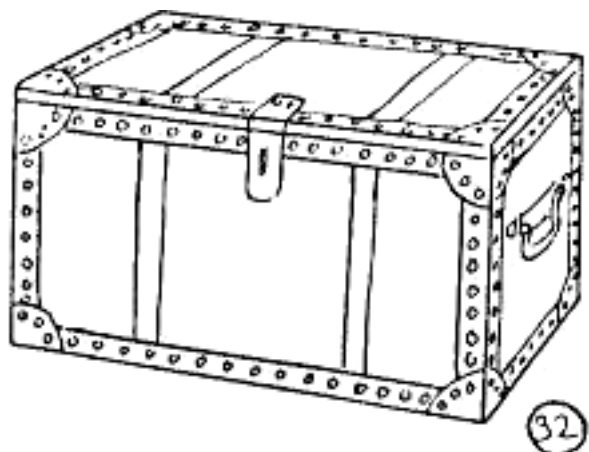
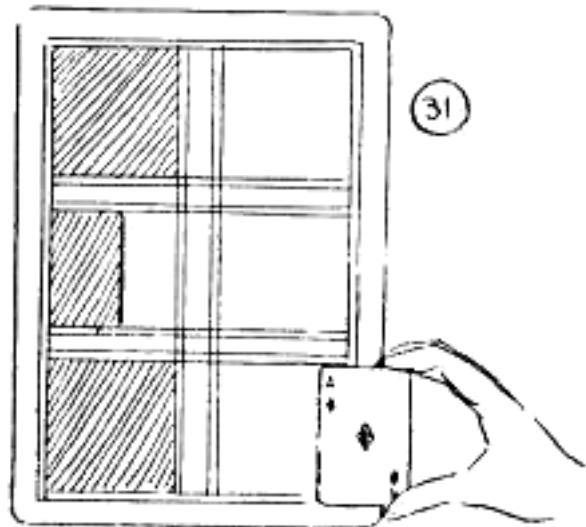
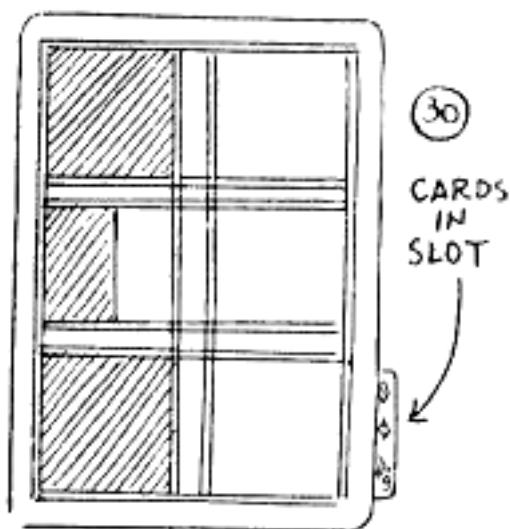
PARAPHERNALIA:

- 1 -- The Treasure Chest.
- 2 -- A table to place chest on.
- 3 -- Articles to be produced.

PREPARATION:

The Treasure Chest:

Fig. 32 shows general effect of the box from the outside. The metal band effect and rivets can be made with paint, as well as the lock.



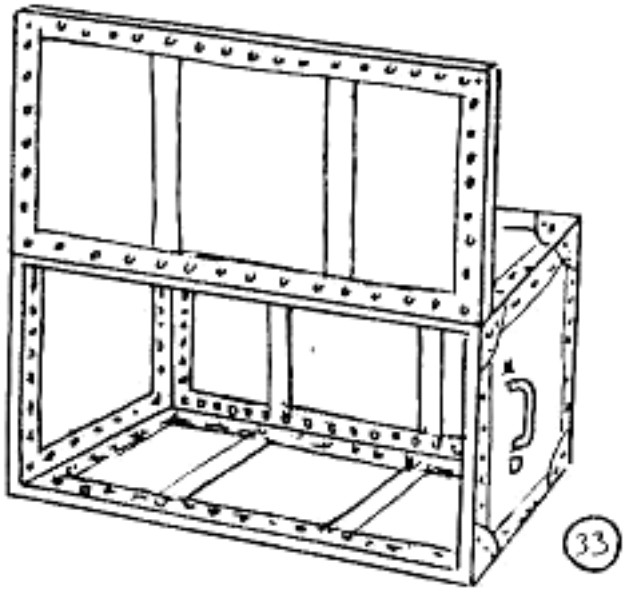
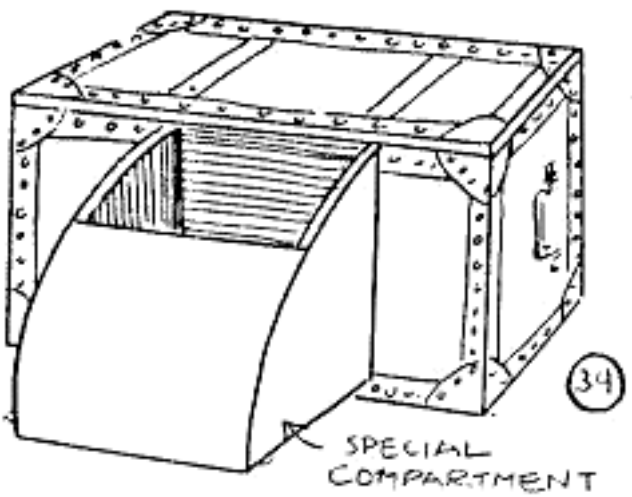


Fig. 33 shows inside of box when box is tipped over and the lid raised.

The box is not difficult to build.

(54-7)



A special compartment must be constructed for the load and fitted into the box. Fig. 34 shows the rear of the box when box is tipped over with lid towards the audience. The compartment is at rear.

The compartment is so made that when box is tipped upright again the compartment will swing into the box.

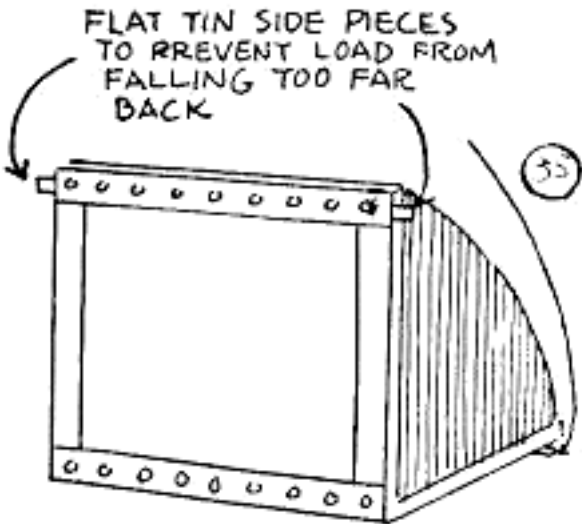


Fig. 35 is a picture of compartment. Note the thin tin side pieces to keep compartment from swinging back too far.

Figs. 36, 37 and 38 show the principle of hiding the compartment.

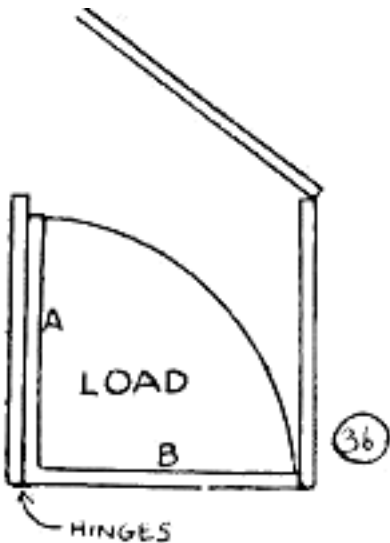
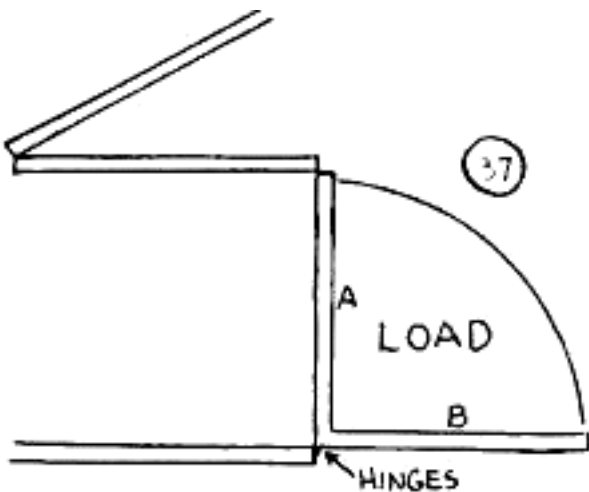
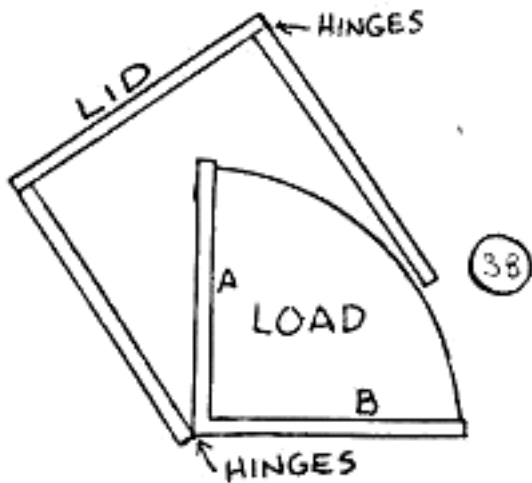


Fig. 36 shows the box with the compartment inside. You will note that the bottom of box is formed by one side of compartment and that the other side leans up against the front side of box. The bottom side of compartment is hinged to bottom of front side of box.



Now if box is tipped forward so that opening is in front you will find that the compartment with load automatically comes into position, Figs. 37 and 34. What appears to be the inside bottom of the box is really a side of the compartment.



Now close lid again and push box back, Fig. 38, to upright position, Fig. 36, and the compartment comes back into the box.

Before the show, the compartment is filled with the necessary production articles. If live stock is used, you can have a slide cover on compartment. Holes should also be cut in the unseen sides for ventilation.

TO PERFORM:

Bring box forward and show all sides. Place in upright position on a plain undraped table.

Tip box over with lid to front. Open up lid showing inside of the box, Fig. 33.

Close lid again and tip box back to normal position.

Raise lid, reach into compartment and make production.

If desired, you can add patter to the trick and tell a fanciful pirate story. When the pirate's chest was dug up, it was found empty. However, a magician discovered its secrets and brought forth the missing treasures.

You could produce jewels, strings of imitation pearls, jeweled crowns, bags of money or handfuls of imitation gold.

You will find the "Treasure Chest" illusion very effective. Professionals value it highly.

THE CHINESE PIGEON PRODUCTION

A good flash and easy to perform.

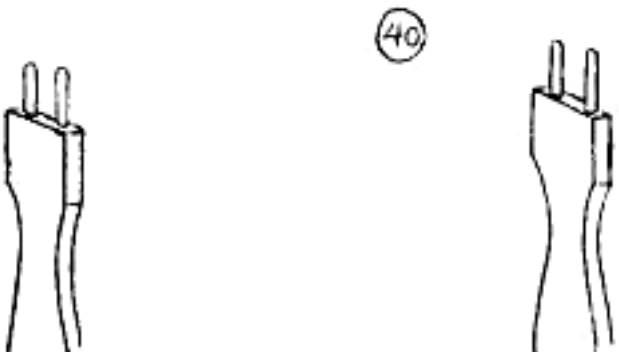
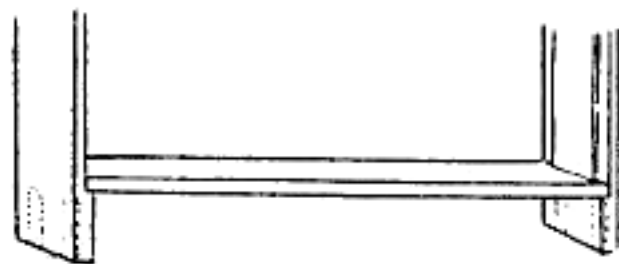
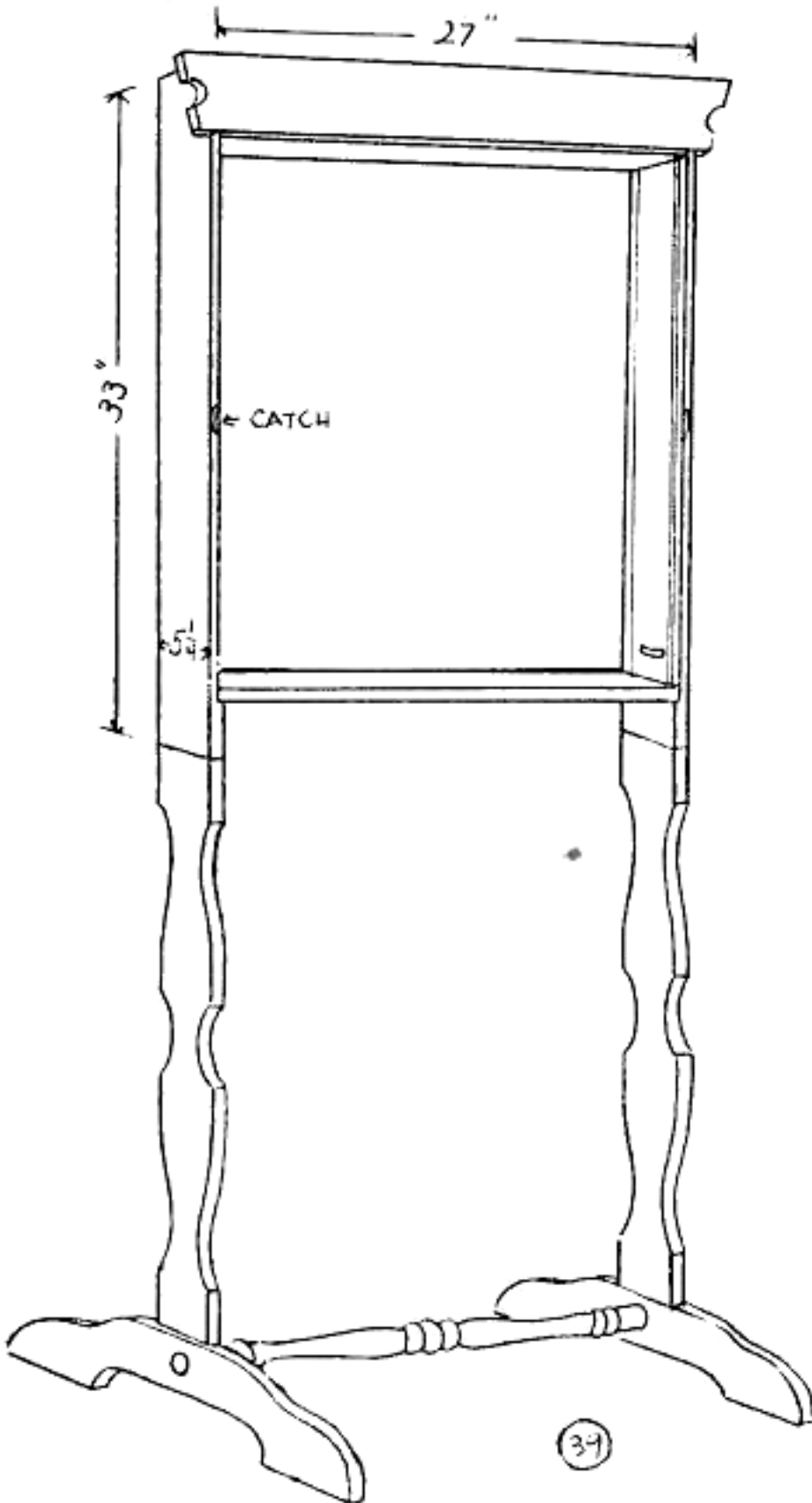
EFFECT:

Performer calls attention to a large easel-like structure with a frame at upper part. Two light frames with paper stretched across each frame, are then shown. One of these is placed at the back of the easel and the other in front. Magician thrusts his hands through the paper and produces a white pigeon. He then breaks paper still further and allows other pigeons to fly out. Paper in frames is then torn away and easel shown to be unprepared as at first.

PARAPHERNALIA:

- 1 -- Chinese easel, which is specially constructed for concealing a few pigeons.
- 2 -- Two frames with paper stretched across.
- 3 -- A few pigeons.

NOTE: This production could also be used for the appearance of other articles. A big silk flash could be worked from it.



PREPARATION:

The Chinese Pigeon Easel:

A study of the illustrations will give the method of construction. Fig. 39 shows the easel before it is decorated. The easel is made into two parts for packing. The upper part with frame fits onto lower base by means of wooden pins, Fig. 40. The center rod in base can be removed for further compactness in packing if desired.

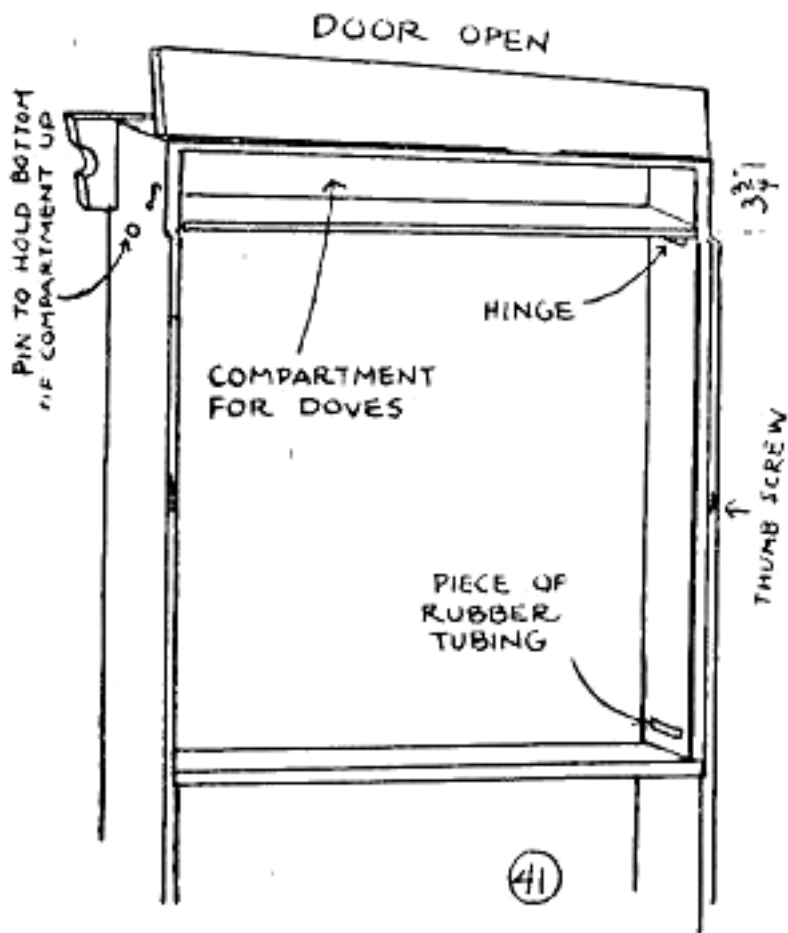


Fig. 41 shows a rear view of upper part. You will note that the apparent decorative panel at the top is really a screen for a compartment to hold the pigeons.

Also that the bottom of the compartment is really hinged at one end and supported at the other end by a metal pin or bolt, Figs. 42-43. When pin is pulled out a bit, door drops to side of frame. To make this practically noiseless, a piece of rubber tubing is fastened to side of frame near bottom for bottom of compartment to strike against, Fig. 41.

(54-9)

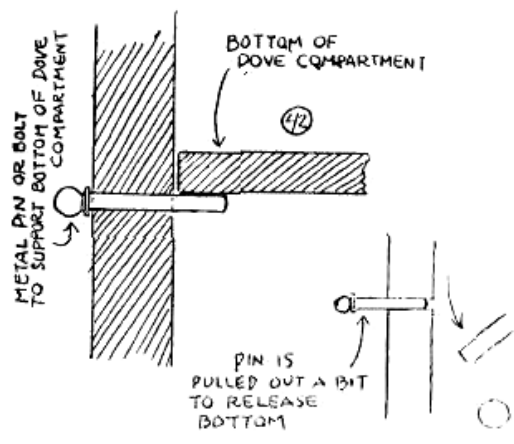
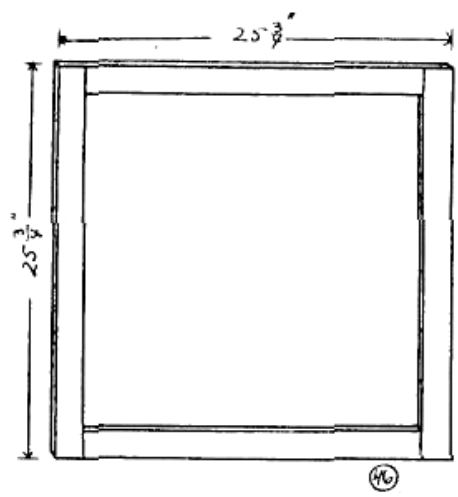
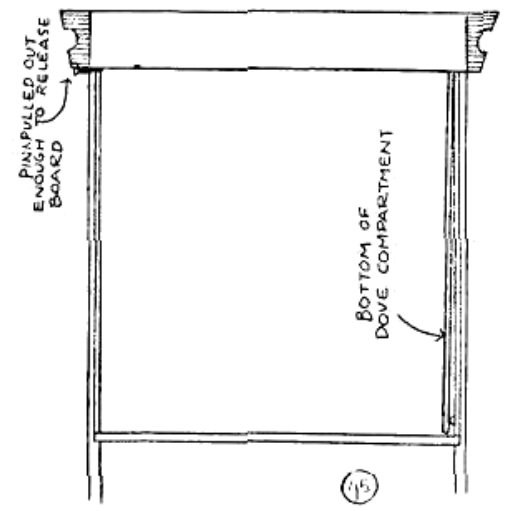
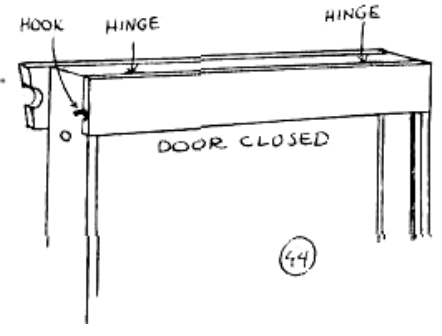


Fig. 44 shows appearance of upper part of easel with pigeons inside compartment and door closed.

Fig. 45 gives a view showing bottom of compartment released and fallen down against side of frame.



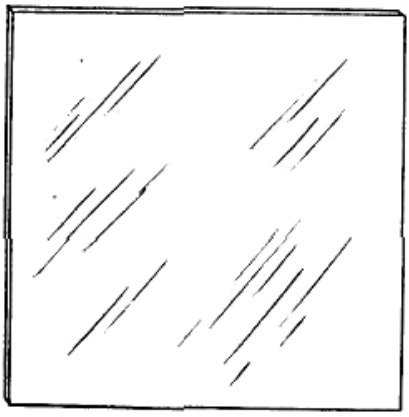
Frames must be built to fit into the frame of easel. Two frames are constructed as shown in Fig. 46 and covered with paper (opaque) as shown in Fig. 47.

NOTE: Easel looks well decorated in Chinese style, Fig. 48.

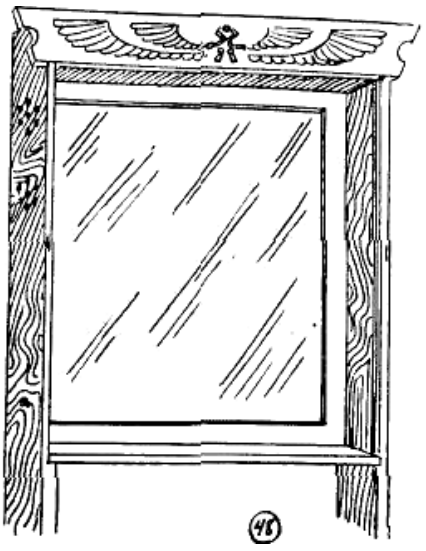
TO PERFORM:

Easel is brought forward with front towards audience. The pigeons are concealed in compartment.

Walk behind easel and show it without preparation.



FRAME COVERED WITH PAPER



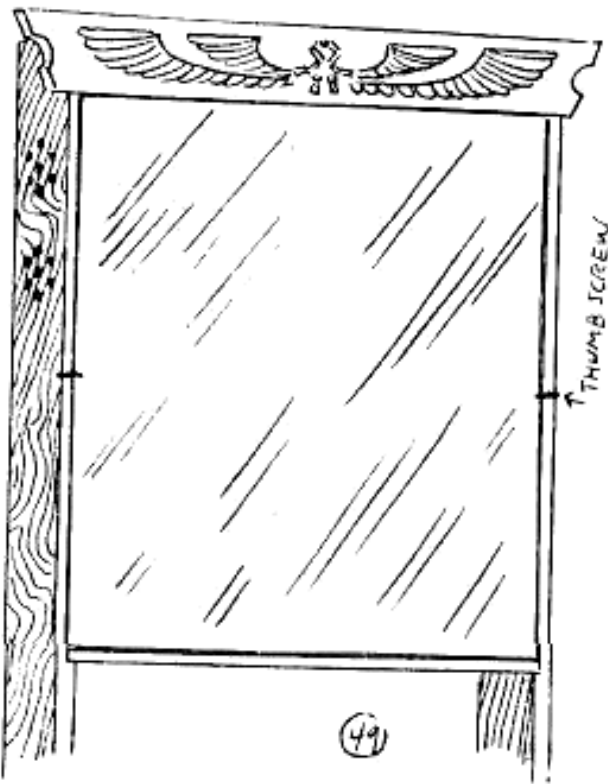
Show one of the frames with paper thereon on both sides and place it on the rear. A thumb screw on each side of easel is used to hold frame in place. Fig. 48.

Show the other frame both sides and place in front of easel, Fig. 49. Hold with thumb screws.

Release pin at side allowing bottom of pigeon compartment to drop down. This drops the pigeons down between the two paper frames.

Break paper about center. Reach in and take out a pigeon and toss it into the air. Tear paper still further and allow the rest of the pigeons to escape. Fig. 50.

Tear off paper as much as possible from both front and back frames so that audience can see through frame of easel again.



THAYER'S SUPER-VANISH OF DOVES

This type of illustration has been very illusive to audiences and is as much of a mystery today as when first introduced. Theodore Bamberg, Servais LeRoy and Dr. Nixon have made feature numbers of "vanishing" doves or ducks in a box, then dissecting the box and table, piece by piece, and showing that the live stock has actually disappeared.

Various methods have been brought out to accomplish the effect. The method I am about to describe was worked out by Floyd Thayer of Los Angeles and has the advantage of causing an instantaneous visible "vanish" of the doves or ducks. They can be seen by the audience up to the last moment then suddenly disappear.

EFFECT:

On the stage is a neatly decorated oriental looking table upon which sets a handsomely decorated box, the lid of which opens at the top. On the front of the box is a door to open down, thus permitting a view into the interior of the box.

Nearby is a cage which contains a number of pigeons or ducks.

Performer shows a rectangular box with bars and opening in front and places same in the large box.

Performer opens front door of box so spectators can see interior.

The bar effect gives a sort of a cage appearance.

Assistant hands performer the doves or ducks one at a time and they are placed in the barred compartment. Audience can plainly see each dove or duck in full view behind the bars.

Performer closes the lid of box when all the live stock has been placed in the compartment.

The performer then fires a pistol and all the birds automatically suddenly vanish while the eyes of the audience are concentrated on them. The disappearance is startling and instantaneous.

Performer now closes up the front door of the box and turns the table completely around showing all sides. The box is then entirely dissected and the parts stacked flat one on top of the other. Finally the table top is removed, shown both sides and lastly the table frame itself.

The birds are gone.

PARAPHERNALIA:

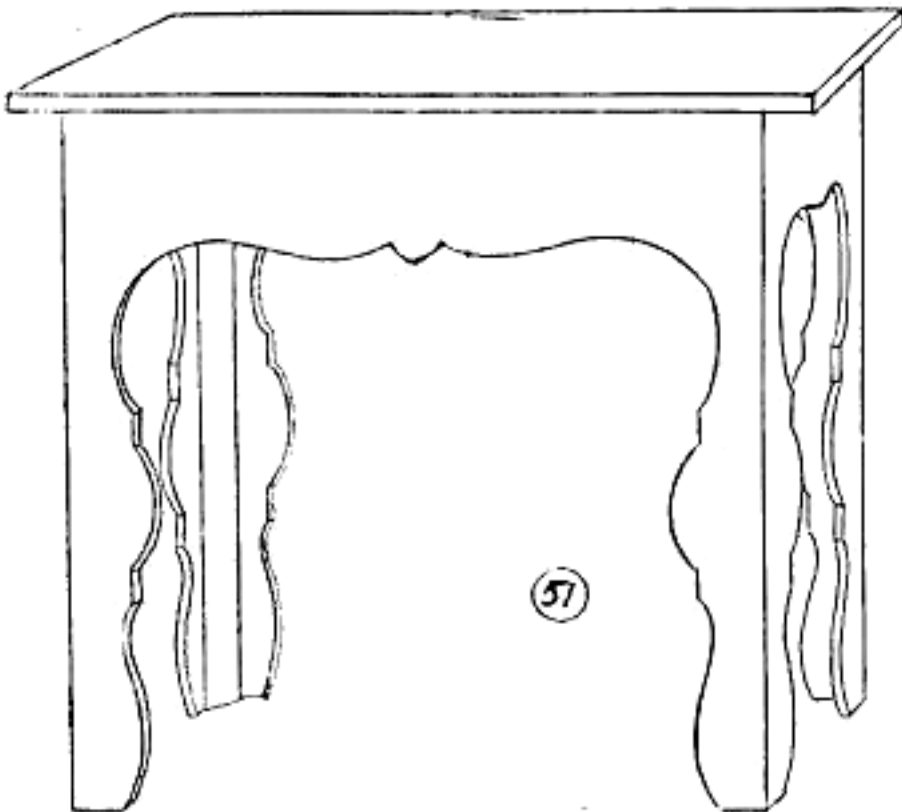
1 - Thayer Super-Vanish Outfit which consists of Decorated Table Specially Constructed Box Barred Compartment for Doves or Ducks Cage for the Doves or Ducks.

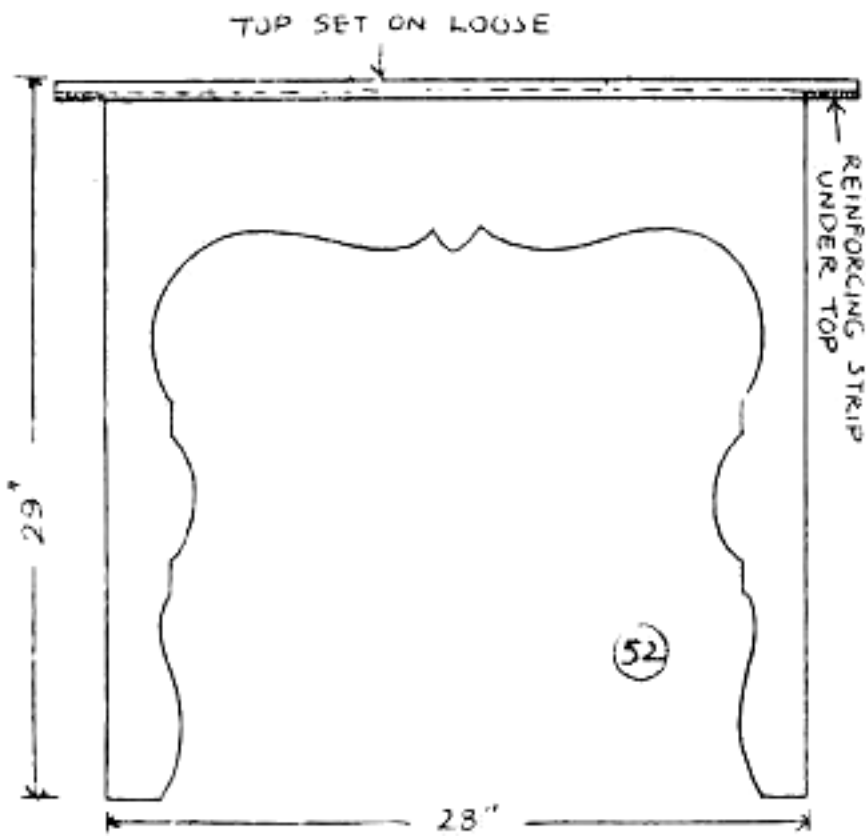
2 - Animals that are to be "vanished" such as doves, ducks or rabbits.

PREPARATION:

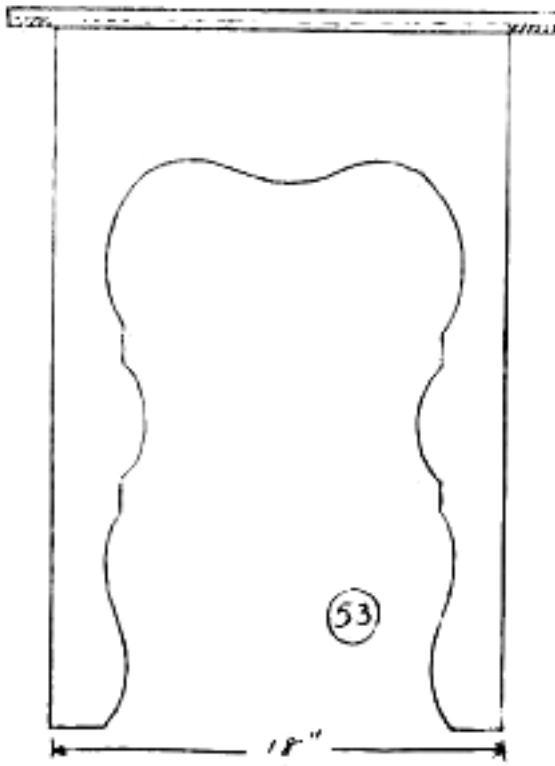
The Table:

Fig. 51 gives an illustration of the table. The sides are cut out with a scroll saw. The top sets on loose so it can be easily lifted off. The table base is 29 inches high, 28 inches long and 18 inches wide.



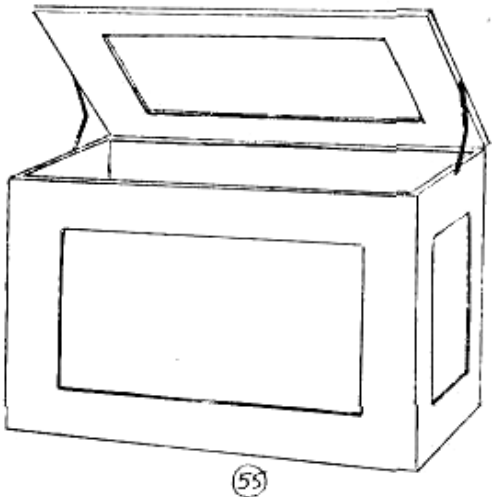
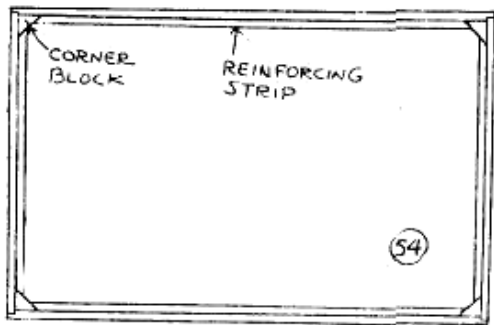


Figs. 52 and 53 give cross section views of table. Fig. 54 shows how sides are held together with corner blocks and reinforcing strips. The table base packs in one piece.



The table should be decorated.

(54-12)



The Box:

From the standpoint of the audience the box looks just like a nicely decorated box with a lid and a door in front which can be opened so that they can look into the box, Figs. 55-56.

However, it is magically arranged in a very clever way.

The sides, top and bottom are arranged so they can be easily dissected. The various sides are held together with hinge joints. Fig. 57 shows this arrangement. The pin is soldered in one part of the hinge and attached to one side of box while the other part of hinge is attached to adjoining side. When both parts of hinge are fitted together the sides are held together but they can be easily separated by moving one side to the side and pulling pin out of other part of hinge. Fig. 57 shows hinge separated while Fig. 58 shows how the sides of box are held together. It requires two hinges on each edge of side to be attached to another.

Fig. 59 shows a cross section of box and arrangement of hinges.

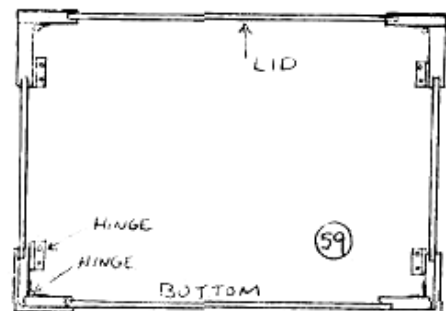
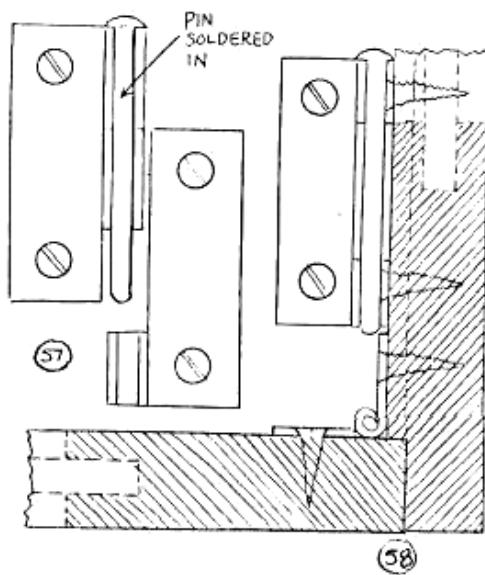
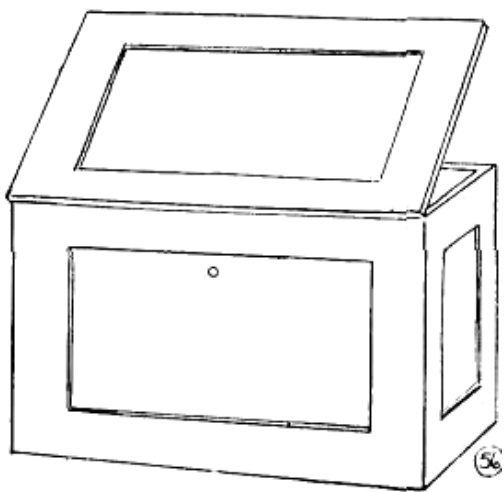


Fig. 60 shows another cross section of the box, looking from top down. On one side you will note a special metal and wooden container that revolves on a pivot and arranged so it can be swung to the inside or the outside.

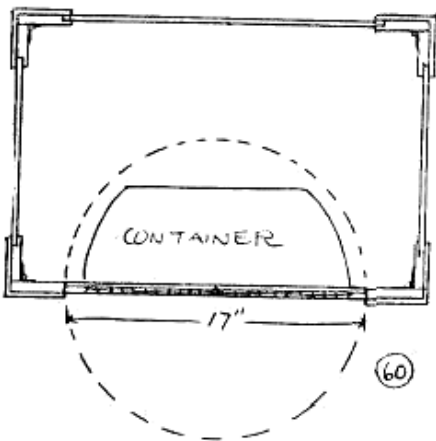
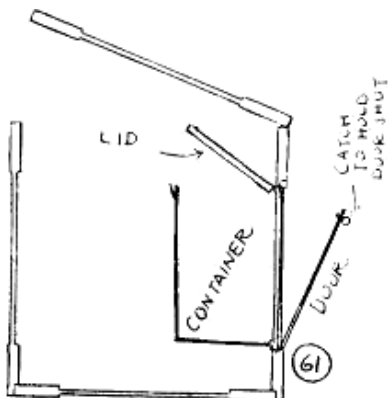


Fig. 61 gives another cross section of the box showing container with its raised wooden lid and door on its front. The container is concealed from audience because it is into this that the doves are placed to be vanished.



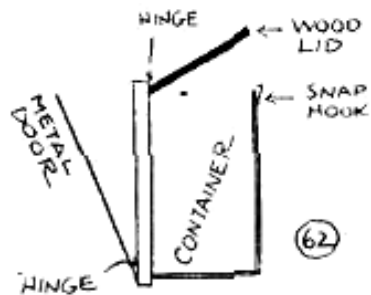
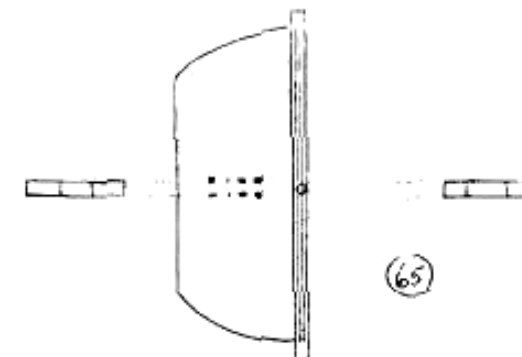
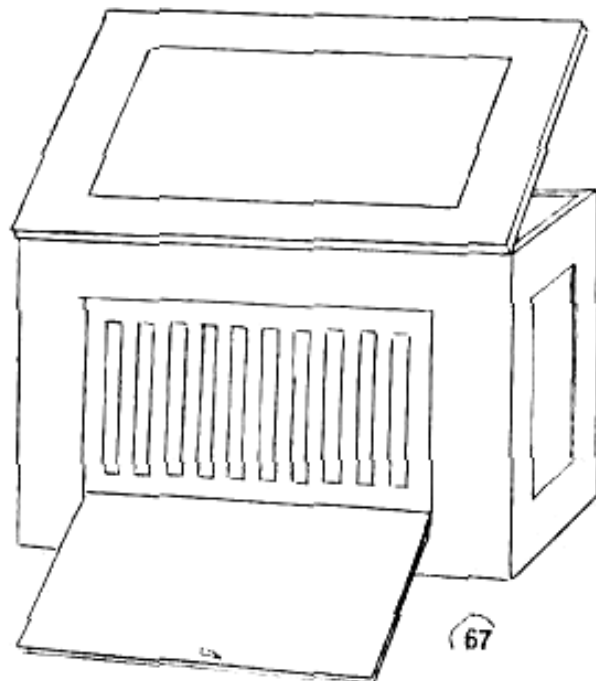


Fig. 62 gives another cross section of the container. Also Figs. 63, 64 and 65. The latter figures show how container is pivoted to swing in the side of box.



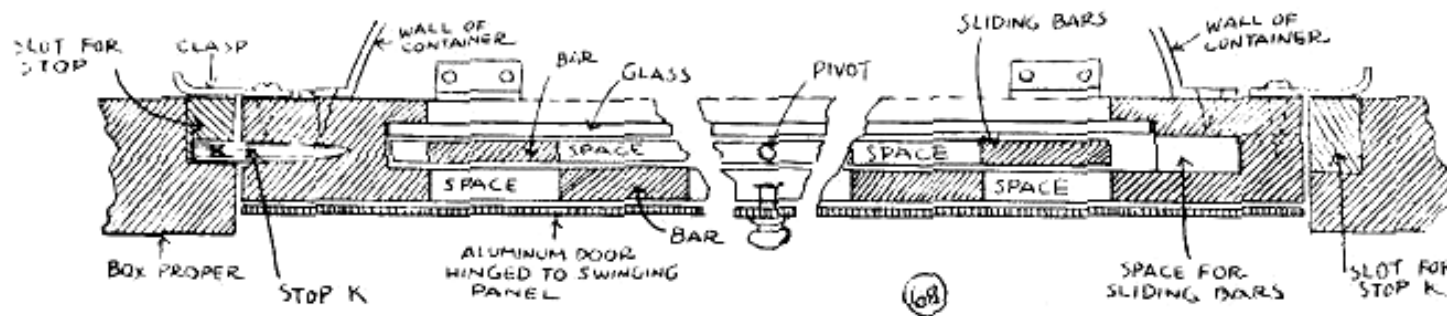
The front part of the container is fitted with special bars - Figs. 62 and 63 show this.

The bar arrangement is for the special purpose of causing the birds to "vanish" suddenly from the eyes of audience and are similarly constructed as the visible "vanish" screen in Lesson 52.



There are really two sets of bars one behind the other. The rear set is covered with black cloth and slides in a groove. When rear bars are parallel with front ones audience can see into box. When rear bars are moved to cover openings in front set, the vision is cut off. Box is dark inside with lid closed and it is difficult to tell whether the openings between bars are closed or open. A piece of glass is behind the rear bars far enough back so as not to interfere with bars sliding.

Fig 68 is a cross section working view of how front of dove container is built. Note the metal door, the permanent front bars, the sliding rear bars and the glass at back. Note also the catch in metal door, the pivot and the small slots cut in sides of box proper to receive Stop K so it can only go so far and hold swinging container in proper position.



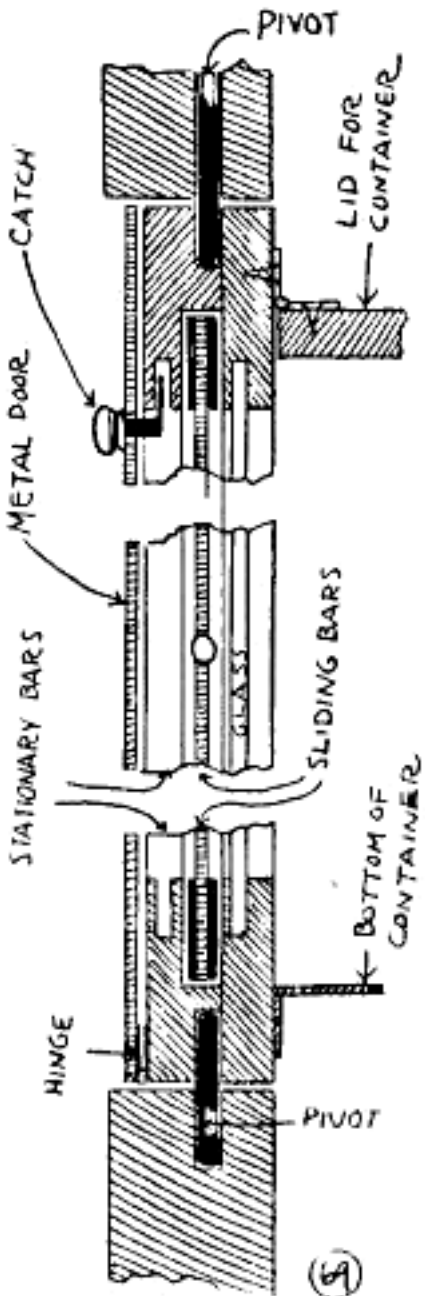
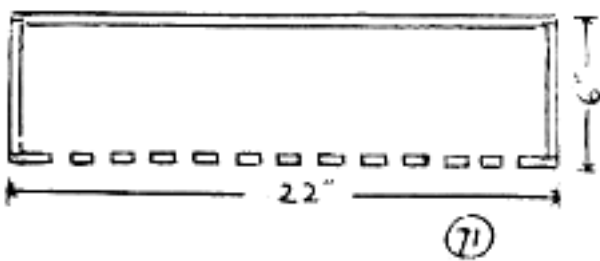
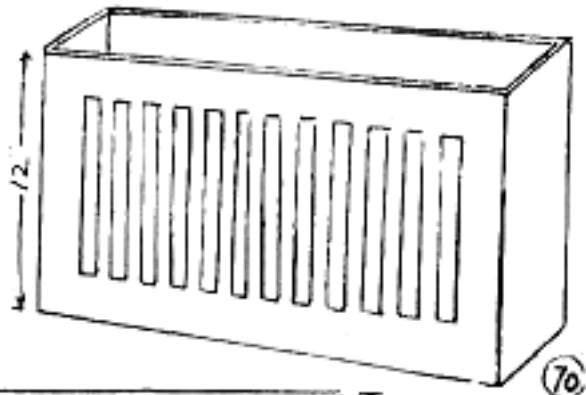


Fig. 69 gives another cross section working view showing position of pivots, etc.

The rear bars are pulled back and forth by means of a string attached to ends of rear bar set. The string runs through ends of front side of container and then out into box proper and through side of box where it can be easily controlled from outside. This is the one that closes the bars and shuts off inside of box view from audience. The other cord to open bars again is merely a short one running out opposite end of front side of container. The container is painted black inside. The front bars are painted the same color as the bars in barred compartment.



Barred Compartment for Doves or Ducks:

This is a special section that is shown to audience and placed into the box for the purpose of holding the animals placed therein. Fig. 70-71 shows the container which is 22 x 12 x 6 inches. It is made of wood. The bars are same size and same distance apart as those in the special container. It is painted black inside. The outside color may vary.

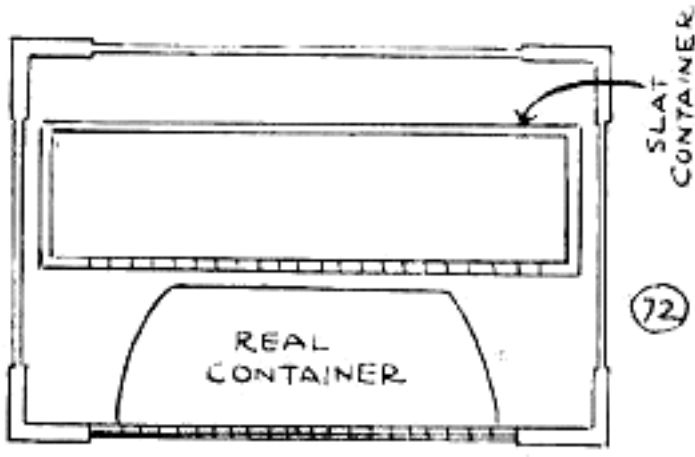


Fig. 72 shows how compartment fits into box behind the dove container.

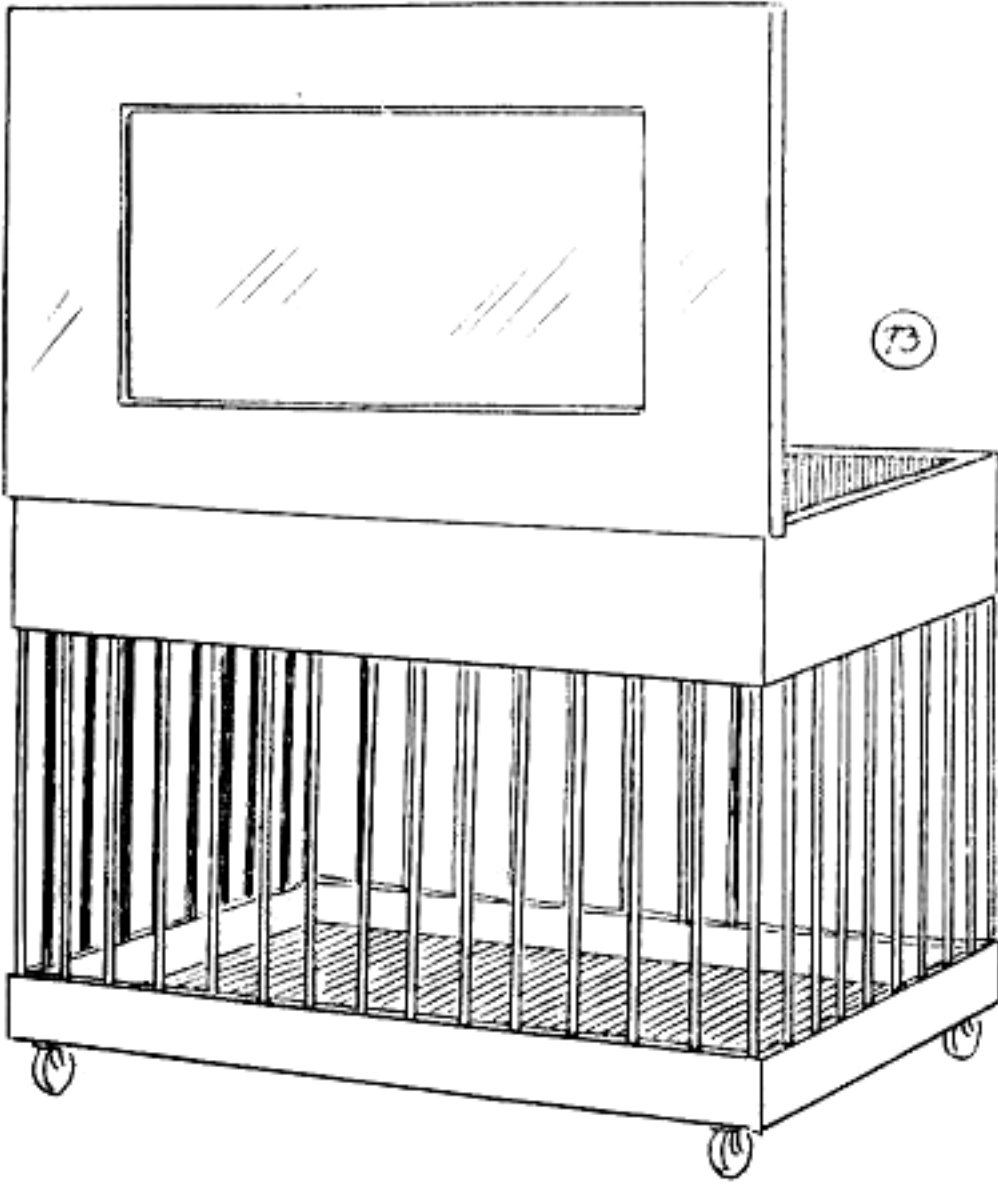
When compartment is put into box audience thinks you slide it up to front of box next to door. When you open front door audience sees the bars of the real container and thinks it is looking at the bars of the compartment you just placed into the box. The audience never knows of the revolving container into which the

doves or ducks really go. They are led astray by the other barred compartment.

The Cage:

To the audience this is just a nicely decorated cage with a hinged top and front door, Fig. 73, for the purpose of holding the live stock to be used in the illusion. The cage, however, has a DOUBLE purpose in that it not only holds the doves or ducks, but has a specially prepared top for the purpose of eventually concealing the live stock to be "vanished".

(54-15)



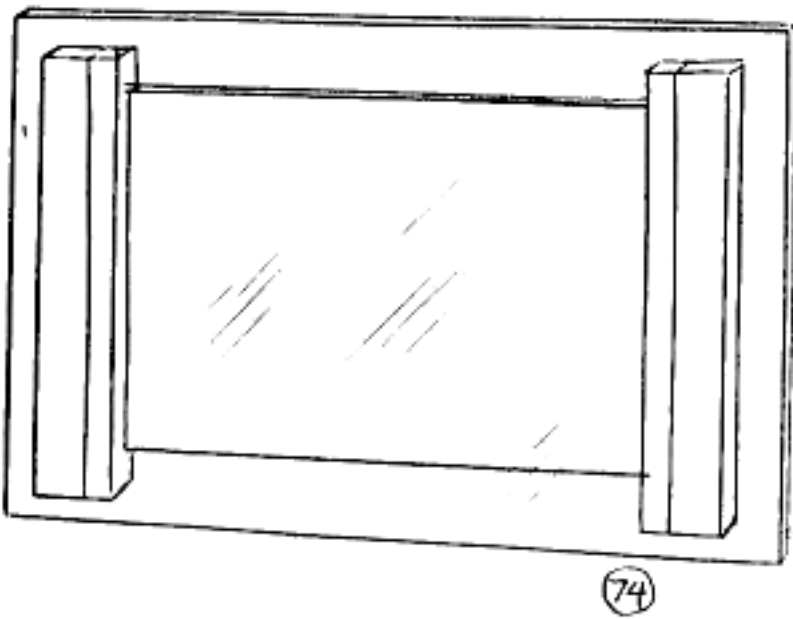
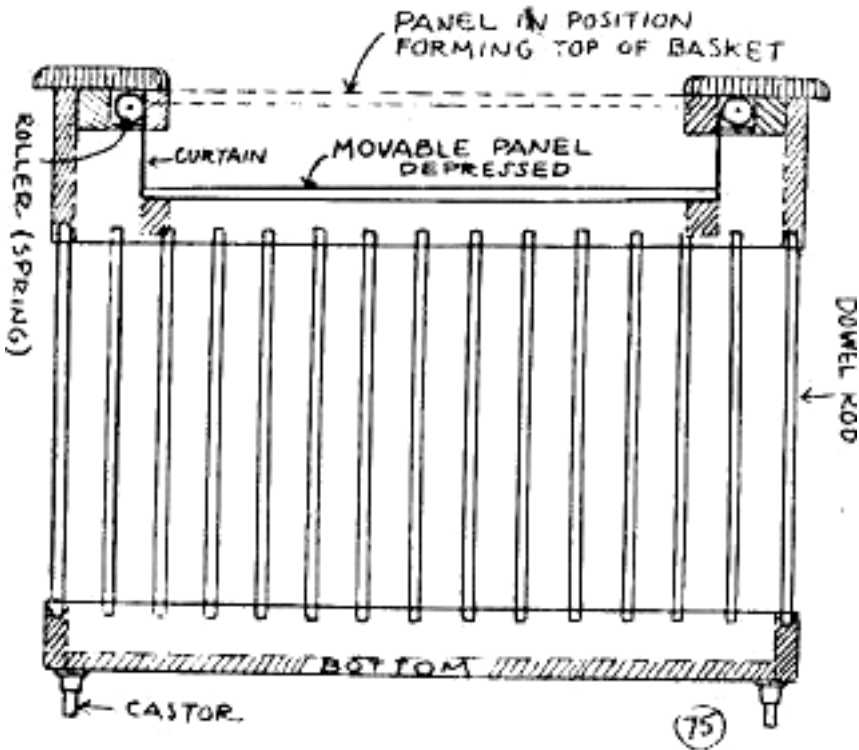
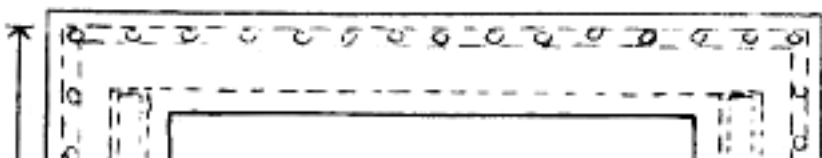
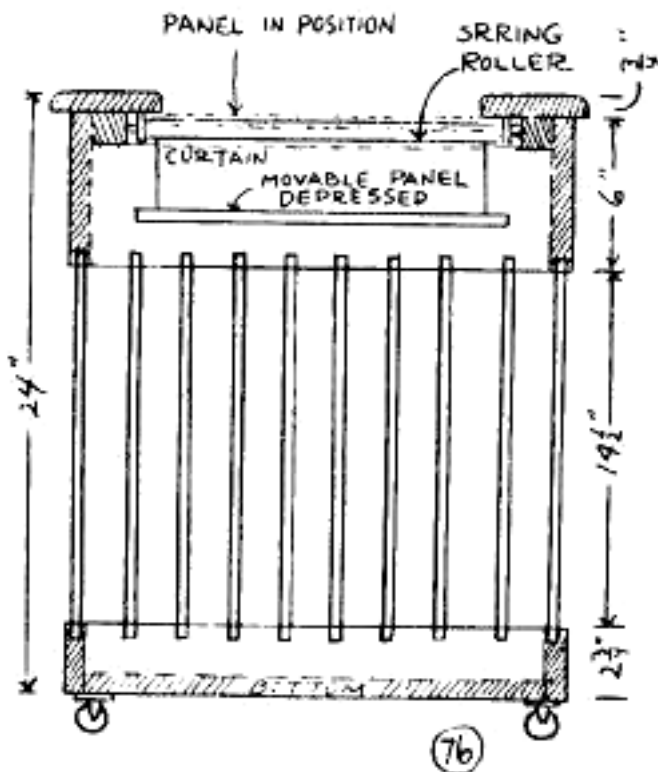


Fig. 74 shows the under side of top which merely appears to be reinforced by two-by-fours.

The cage is 20 inches wide, 30 inches long and 24 inches high.



Figs. 75, 76, 77 and 78 will give you a good idea of the construction of the top of cage with its movable panel which can be depressed at will. This is accomplished by curtains on spring rollers. The spring rollers have enough tension to keep panel in normal position until undue pressure is brought to bear on panel when panel sinks down supported on each end by a curtain.



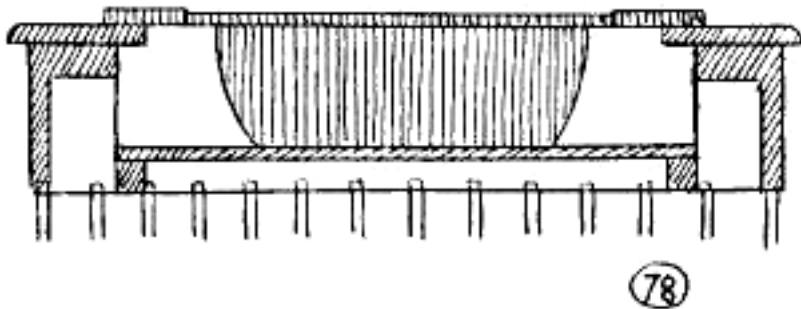
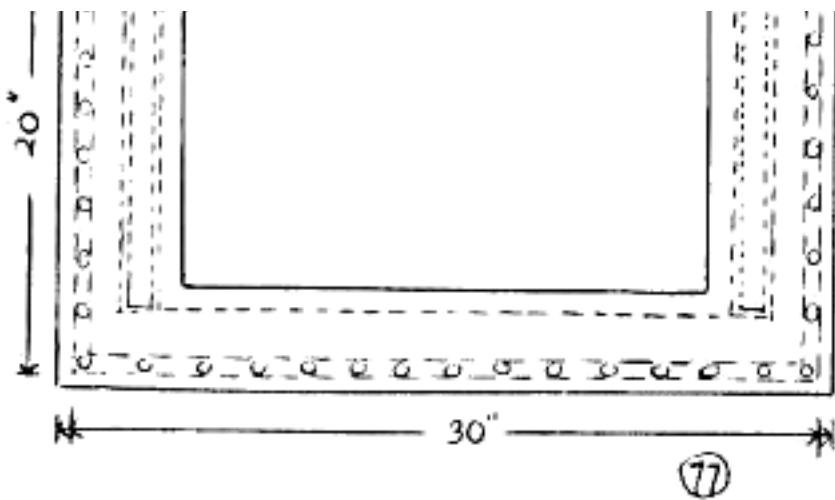
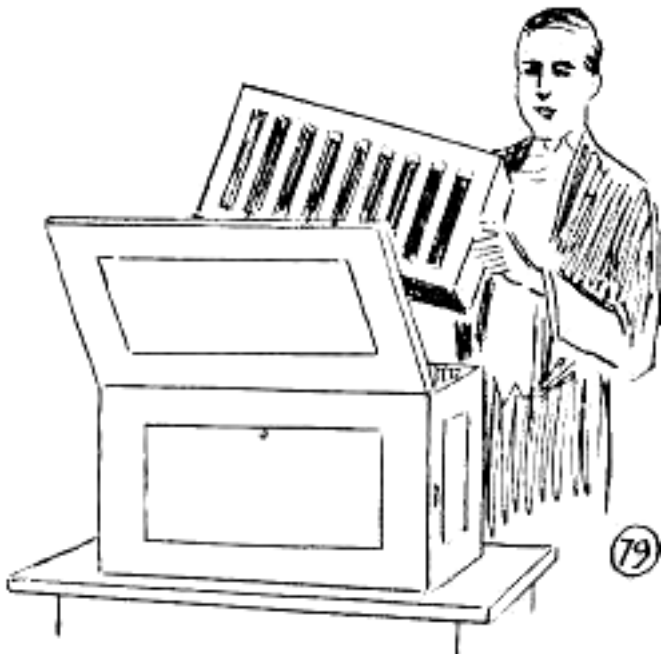


Fig. 78 shows cross section of panel depressed when the side of box with container full of doves or ducks is placed on top of cage.

This gives appearance to audience of side of box being flat. They cannot see one side of the side but when it is laid down flat on top of cage they naturally take it for granted that there is nothing on other side, never figuring that there is a load which pushed down the top panel of cage to make room for it.

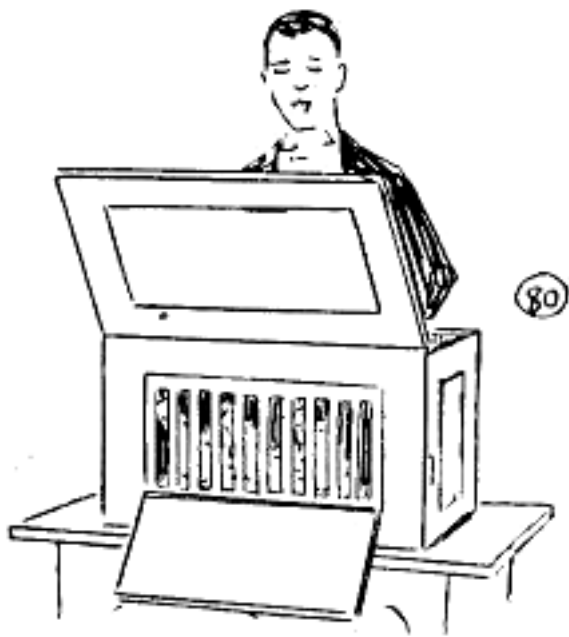
TO PERFORM:

Have box on table with the door side of box towards audience as in Fig. 56. The cage with birds should be at your right side - say about three or four feet away.



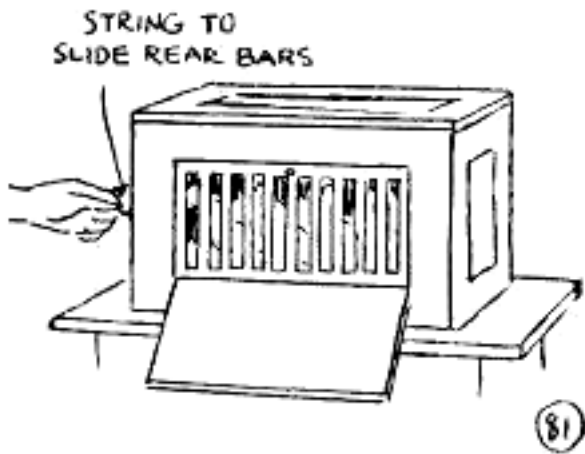
You open top lid of box. This should be kept in place by metal holder. Pick up the barred compartment and show it all around and place in the box - Fig. 79. Fig. 72.

(54-16)



Open the front door of box as in Fig. 67 showing the audience the barred compartment you have just placed in (?). What they really see is bars of the revolving container.

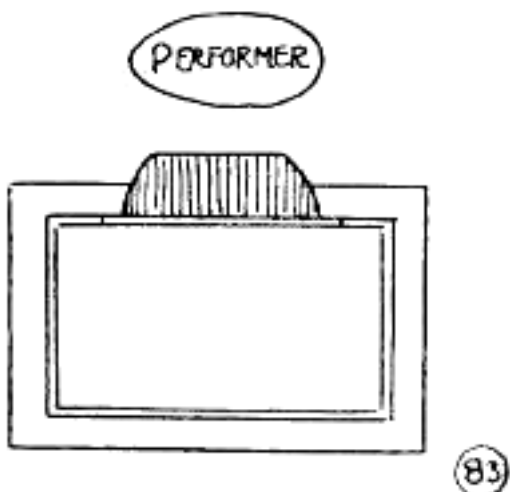
Assistant opens cage and hands you the doves or ducks one at a time. You hold each one up a moment, then place into the real container. Audience can see each bird as it is placed in, through the bars - Fig. 80.



When all the birds are placed in container, fasten the wooden lid on container and shut down the lid of box.



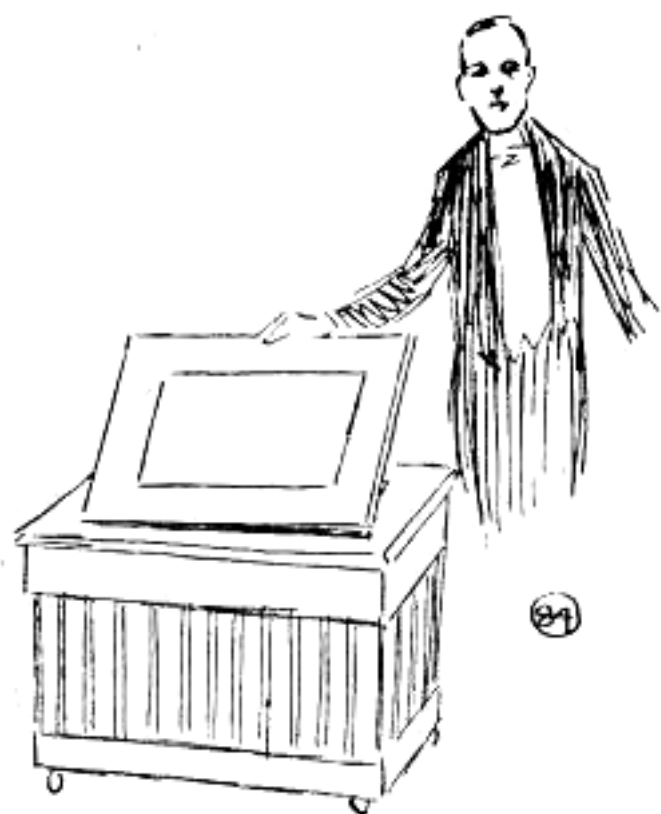
Step to side of box where string is to cause the "vanish", grasp string with nearest hand while the other hand you point to doves or ducks inside. Pull string which closes openings between bars and birds have seemingly "vanished".



If you care to, you can shoot a small pistol, loaded with a blank cartridge at the moment you pull the string. This adds a little action to the "vanish".

Close the door and fasten with catch. Go to rear of table and box and raise the lid. Remove the barred compartment, Fig. 79, and show it inside and out to be empty. Place aside on the floor.

Close lid again and revolve the table with box so that door on front of box comes to the rear. Undo catch, push side of revolving panel and cause container to come to the rear outside of box - Fig. 83. Adjust catch to hold panel firmly in place.





Remove top of box sliding to side and separating hinges. Place on top of barred compartment after having shown top freely. Remove front of box and give to assistant, standing to the right, who displays both sides while you remove back side and quickly place it on the top of cage - Fig. 85. Let it drop onto drop which pushed down the panel and adjust itself into position - Fig. 78.

Assistant places side of box he is holding on top of this.

Then the other two sides are removed and placed on top of cage with other sides and finally the bottom is raised up, showing both sides, and placed on other sides.

Here you give time for applause and bow slightly. You should step slightly forward for this.

Following this, you should pretend to hear someone say that birds are in the table. Then shake your head, appear to hesitate, as in doubt, but finally go over, stand behind table and lift up the top. You should lift it up with a pretended exertion to give the impression that the top is very heavy. Do not let audience see the under or rear side of it. Pretend that the doves or ducks are really on the back of it, but that you are trying to conceal same.

Another good effect is made by tucking your hand under top while you are lifting it as though tucking birds in some place; do this, even though you have assistant reach under and tuck and finally help you in lifting it off. Set top down on left side of table base very carefully on one corner. Then shake your head and say, "Not there". But audience is not satisfied if you have properly worked it up and believe they are on the back of board.

Finally pretend to hear someone say, "Turn it around". It is very likely someone will make that request. Then turn board around as in Fig. 85 from one corner to another without showing back of the board. Then inject this patter, "Oh, you mean turn it around the other way". Reverse the turning process in the opposite direction, but do not expose rear of board.

"Now everyone is satisfied. The doves are gone".

Following this, there is generally a commotion amongst the audience until the board is reversed to show the back as well as the front.

Now have your assistant grasp board as you walk to rear of table base. Pick it up and hold it up so that audience can look through the opening seeing you on the other side. Place base on floor and bow slightly to the applause.

NOTE: IN THE PRESENTATION OF THIS "SUPER-VANISH" YOU WILL JUST HAVE TO STUDY OUT THINGS WITH THE MATERIALS AT HAND. STUDY CLOSELY THE VARIOUS MOVEMENTS AND SPEED IT UP AFTER THE "VANISH". THIS IS AN EXCELLENT EXPERIMENT FOR MISDIRECTION.

Handle the side with container on as though it were just as light as the other sides. You will get so you can just apparently throw it on cage as far as audience is concerned even though you really use extreme care. Lower edge of side must touch top of cage before side is allowed to drop down. Your speed on dropping down will depend greatly on the working condition of your top panel in top of cage.

FOR PACKING:

In packing the illusion the box fits into the cage, and the cage in turn into the table base. It is well to place all into a specially made crate for protection.

In performing it is well also to place sawdust in bottom of cage as protection when doves or ducks are inside.

A large, elegant handwritten signature in cursive script that reads "Hurlan Tarbell". The signature is centered on the page and is the most prominent feature.

TARBELL SYSTEM, INCORPORATED,

Chicago.

* * *

LESSON 55

In your next lesson I will explain three excellent illusions.

- 1 - The Rebirth of a Princess.
- 2 - The Mystery of the Dancing Girls.
- 3 - The Doll House.

NOTE: When we have illusions built for magicians we go according to latest improvements. If we find a superior method of working we give the magician the advantage of same. We want the profession to have the best. For this reason, we do not guarantee that an illusion will be exactly constructed as described in the course. We want you to have the same advanced service that we want ourselves. However, in most cases the illusion will be exactly as described in these lessons.

(54-19)

THE EGYPTIAN MUMMY

The Re-Birth of a Princess:

In this lesson I shall take you back - back - to some 5000 years before Christ when the historically famous Egyptian race ruled the Nile Valley. They were a slender, fair-skinned, wavy brown haired people FAMED for their accomplishments in the higher arts. Their accomplishments stand almost without equal. The study of Egyptian magic is most fascinating.

Even to this day the mystery of the Egyptian Mummy and their art of embalming stands unequaled, unsolved. Down, down, through the ages this has been a mystery of mysteries.

For that reason my Illusion, "The Egyptian Mummy" holds fascination. It will be my endeavor now to so explain and describe it as to make it easy for you to master. I urge you to give this illusion your most careful study because you will later find it to be a very valuable asset - properly mastered you will find it possesses good entertainment value.

EFFECT:

Performer calls attention to the Egyptian burial case, showing all sides. The front door is opened revealing two inner doors on which are painted the picture of a mummy case. These two doors are in turn opened revealing the figure of a mummy inside the cabinet. The mummy is removed. The back door is opened wide and spectators allowed to look through the cabinet or mummy case. The rear door is closed, the mummy placed back in position inside and the doors closed. Upon opening the front doors again, a girl dressed as Egyptian Princess is seen, the mummy having vanished. Apparently the mummy has changed to a living Princess.

PARAPHERNALIA:

- 1 -- The illusion cabinet.
- 2 -- An imitation mummy.
- 3 -- Girl assistant dressed as Egyptian Princess.

PREPARATION:

The construction of the illusion cabinet itself is best seen by studying the illustrations.

Fig. 1 shows the outward appearance of the mummy case standing upright on a platform. The platform should be large enough so that a person can easily stand on either side of it, and the legs should be out far enough so that cabinet will not tip over with a person standing on the ledge of platform. The platform of course extends around all sides of the cabinet. Fig. 2. It can extend out nine inches to a foot at sides.

The outer part of cabinet is decorated so as to represent an Egyptian burial case. There are handles on two of the sides, which not only serve as decorations but to aid girl assistant in standing on platform at side of the cabinet.

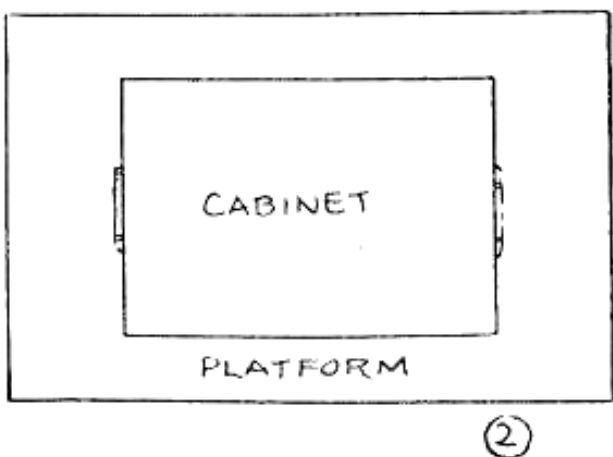
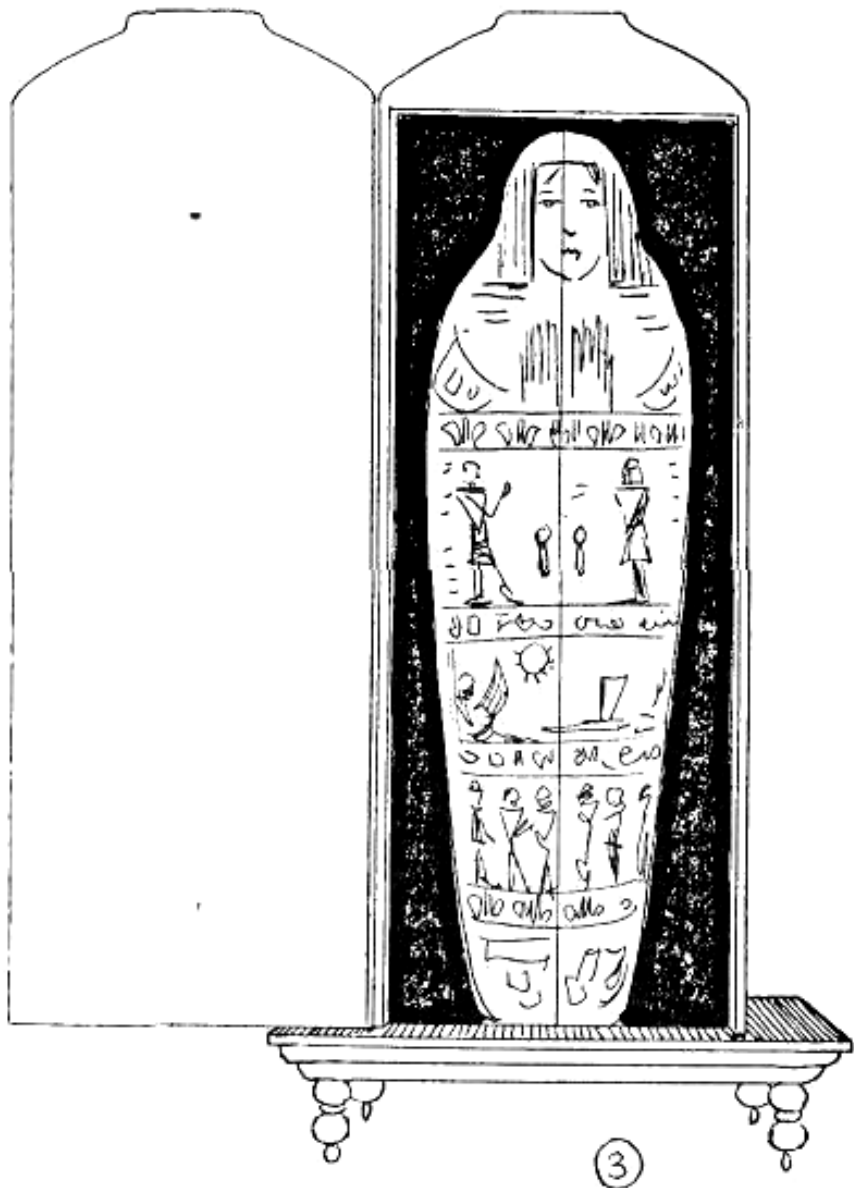
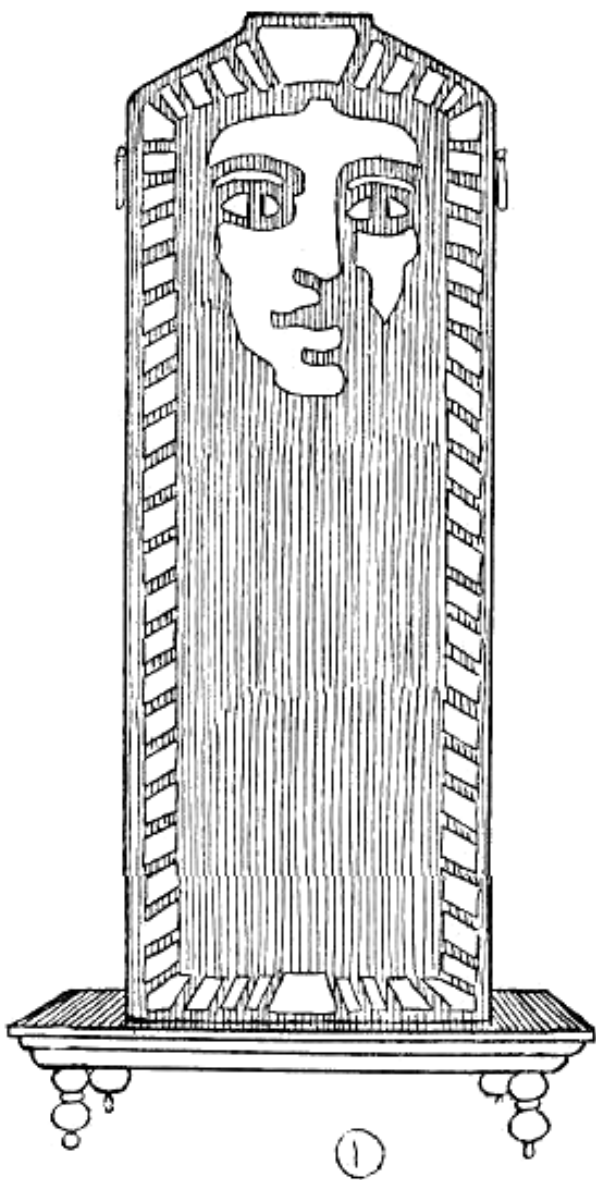


Fig. 3 shows cabinet with front door open revealing a picture of a mummy case painted on a black background. The more gorgeous this case can be painted, the better, even using gold leaf. The background need not necessarily be black -blue or green will do almost as well. You will note that the case is painted on two inner doors and that there is a handle on each door so that each can be easily opened. The two inner doors are set back far enough so that the handles do not interfere with the front door when it is closed.

THE MUMMY:

The two inner doors are opened, revealing a mummy inside. It is suspended by a hook on rear door. Fig. 4.

The mummy is made by cutting out a wooden figure and covering it with cloth or covering a wire frame with cloth. The nearer the mummy looks like a real one, the better. The mummy need not be over 4 3/4 or 5 ft. tall. There is an eyelet at the top and rear to enable you to fasten it on a hook on rear door.

The rear door really contains a revolving panel and the mummy is fastened to the revolving panel. By pushing panel the mummy is easily revolved to the rear of the cabinet.

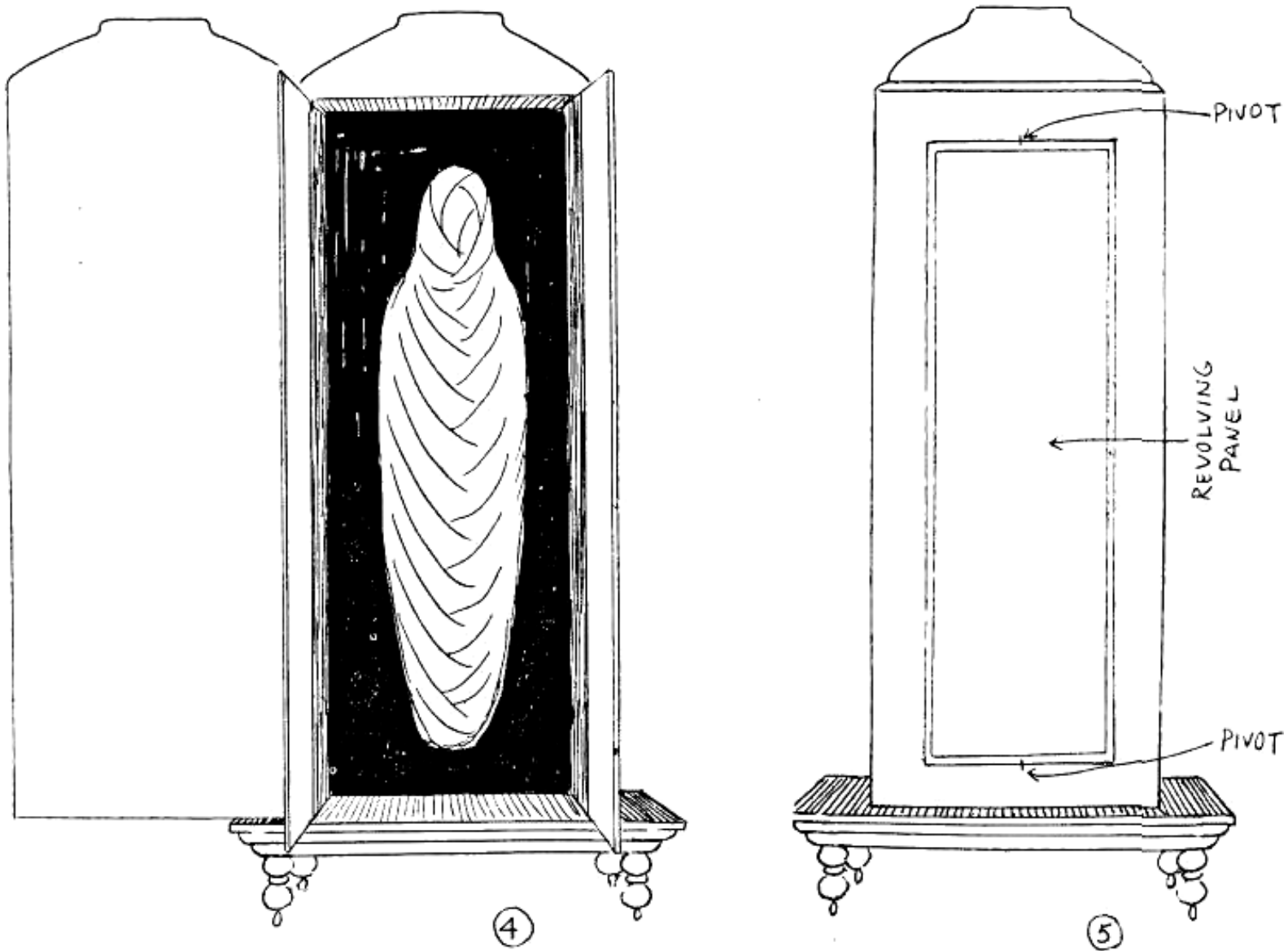
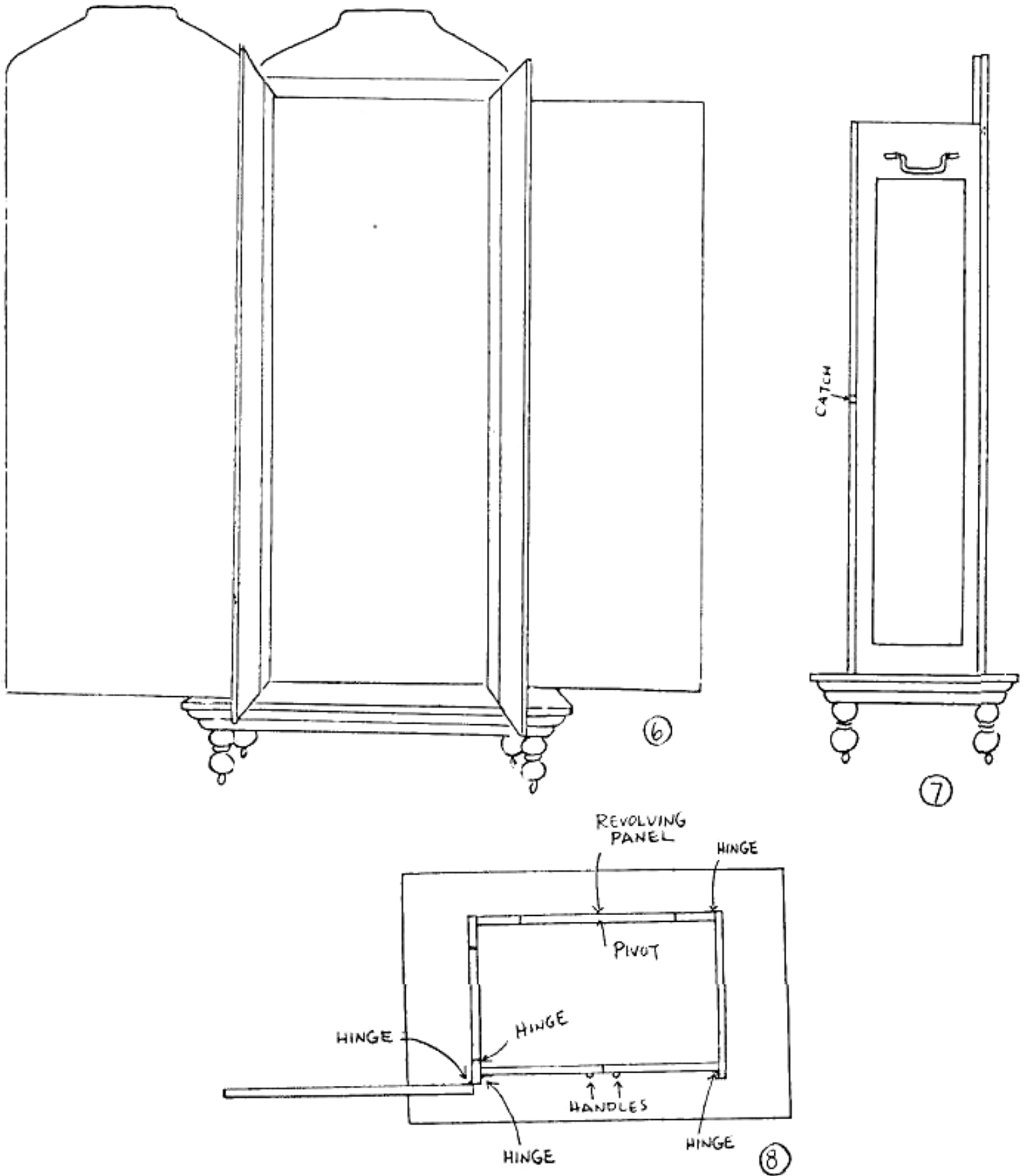


Fig. 5 shows the cabinet from the rear and the position of the panel. A line of decoration hides the fact that there is a magic panel. The panel is held in place by two catches so that it will revolve only so far and can be kept in place. It must be controlled by assistant inside cabinet.

Fig. 6 shows the cabinet with back door open, which enables spectators to look through the cabinet and see that nothing is concealed.

Fig. 7 shows the side view of cabinet. Note position of handle and the panel beneath. This panel is a trick one - it is really a door that opens inward.

Fig. 8 gives a cross section drawing of the position of the doors and hinges.



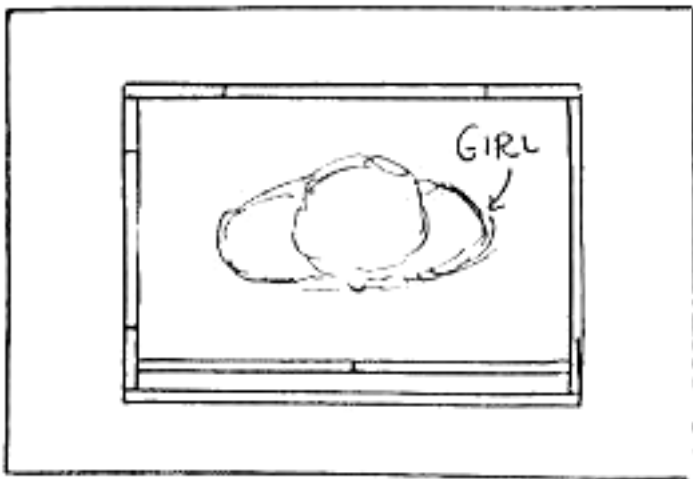
For temporary use the cabinet could be built quite solid, but for traveling use the cabinet must be made so it can be dissected. This will necessitate the sides being held together by hinges with removable pins, or by the use of wing nuts, screws and bolts. The upper cabinet must fasten securely to the platform. There are castors on bottom of legs of platform so that platform can be easily revolved.

To simplify construction, the revolving panel in rear door could be omitted by using the picture of a mummy painted on a flat piece of wallboard. This wallboard is hung on rear door - to make it easy to get rid of, it is fastened to side of cabinet. The inside of cabinet is black and the rear of mummy is also black.

The idea of illusion is that the picture of the mummy changes to a live Princess.

For size you should allow about 6 feet for inner height of cabinet and width should be about 26 inches and depth about 22 to 24 inches.

The sizes I give you of illusions are only approximate in many cases. These may be varied in actual illusion building if they can be improved upon. I am to take into consideration the new operators who have not the experience of a Servais LeRoy in concealing an assistant in a seemingly impossible space. It is always best to give the new illusionist in the field a margin of safety.



9

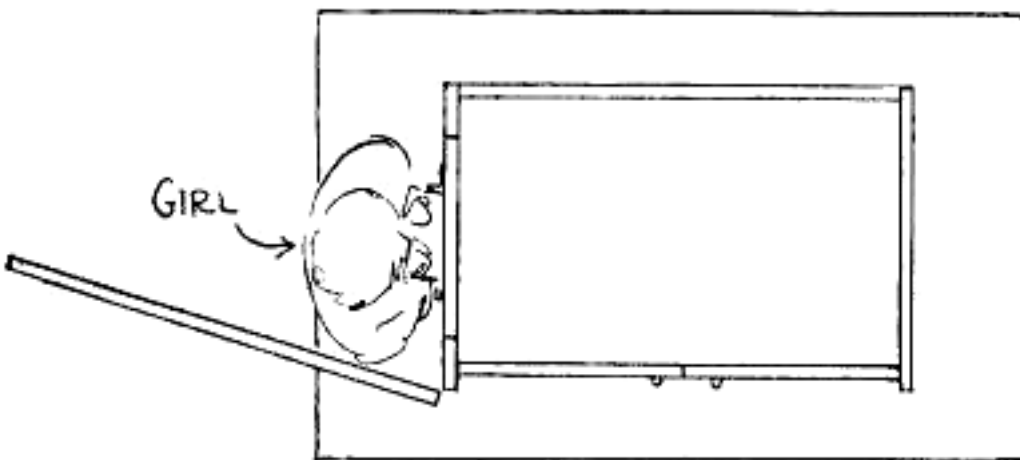
TO PERFORM:

The mummy is hanging on the rear door. The girl is inside the cabinet and the doors are closed. Fig. 9.

The cabinet is brought to the front of stage and revolved bringing the front door to the front.

PATTER:

"As you know, the mystery of the great Egyptian Mummy has long been the mystery of mysteries. This is a mystery nearly 7000 years old, brought from far-away Egypt, the land of the Pharaohs. This now represents the burial case of a famous Egyptian Princess."

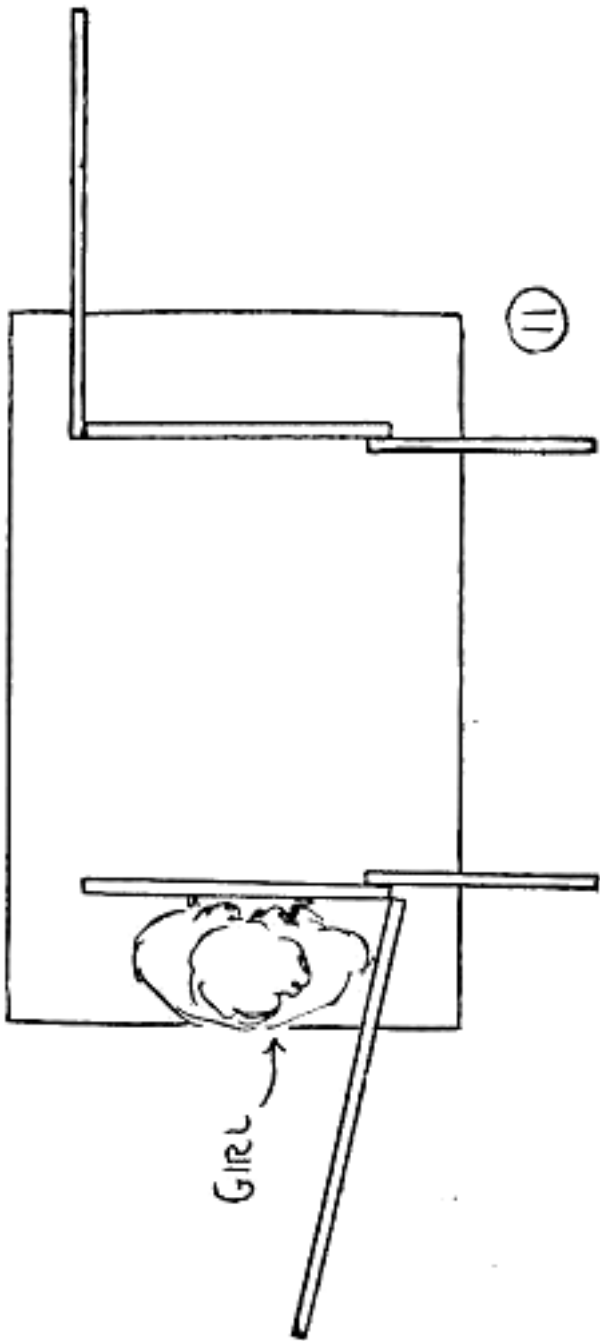


10

Open the front door, Fig. 3.

As you start to talk again, girl inside quickly opens up panel door in side of cabinet, goes through the opening and stands on the platform aiding in keeping balance by holding onto handle above. She immediately closes panel door after her. Fig. 10.

The performer stalls for enough time by saying:



"The Egyptians spared neither time nor expense to protect the dead that their bodies would last down through the ages. In the outer case was an inner case and here on the mummy case one could read the history of a life. The finest artists of Egypt were brought into play. We open the inner doors and behold - "

Open the two inner doors, Fig. 4.

" - the mummy of a great princess. Thousands upon thousands of years have passed since the princess lived."

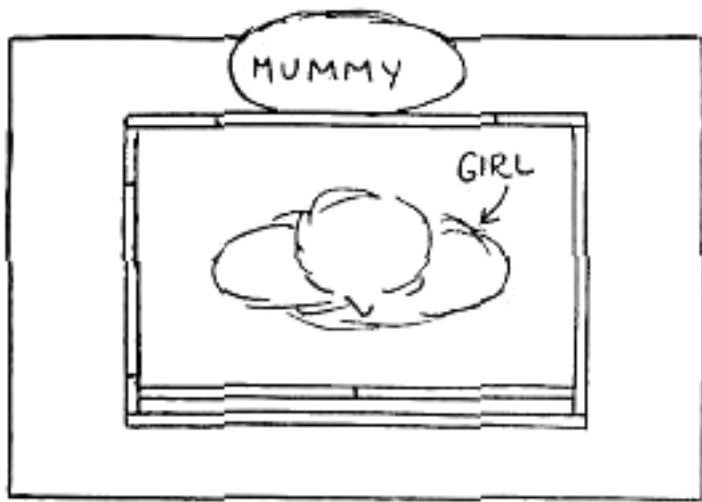
Remove the mummy and give to an assistant to hold. Open the rear door and show the cabinet empty, Figs. 10 and 11.

"So the mummy rests alone through the years."

Close rear door again and fasten.

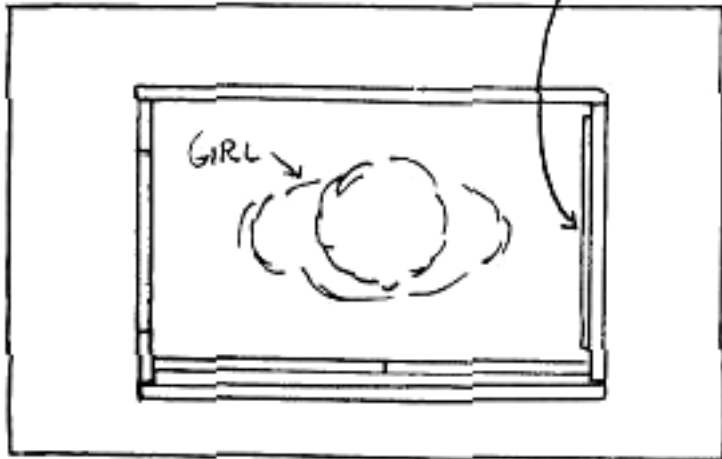
Place the mummy back in cabinet and fasten to the panel in rear door.

Close the two inner doors.



12

PICTURE OF MUMMY



13

The moment doors are closed, girl assistant pushes panel door in and goes into cabinet quickly closing it again.

Close the front door.

Girl revolves panel in rear door so that mummy comes to the rear of the cabinet. She then stands facing front of cabinet. Fig. 12. If using a picture of mummy, simply hang it at side of cabinet, Fig. 13.



"And now. - I shall soon prove to you the truth of an old legend that sometime a magician would come and by his great magic art restore the Princess back to life again. Watch now, watch closely - "

If at this moment you could have an assistant off stage clash two cymbals together or strike a gong several times, the effect would be heightened.

A few odd magic words injected here will help.

Open the outer door.

Open the inner doors, revealing girl assistant. Fig. 14.

Effect a momentary surprised look - smile - bow and say:

"And - Behold the Princess!"

Assist her from the cabinet.

Special Note: Time and time again, throughout my

course I give to my Tarbell Students - new and exclusive Magic Feats and Illusions that no one else has or can secure except through the Tarbell System, Inc. Thus you KNOW, when you give your performances, that you are giving your audience new magic. I hardly believe that it is at all necessary for me to tell you what this means to you - it only again proves what a VALUABLE course the Tarbell Course is! This course not alone gives you effects of the days gone by that have stood the acid test of time - but, in addition to all this - it arms you with an array of new material that will make you stand head and shoulders above the ordinary performer of magic.

(55-6)

THE MYSTERY OF THE DANCING GIRLS

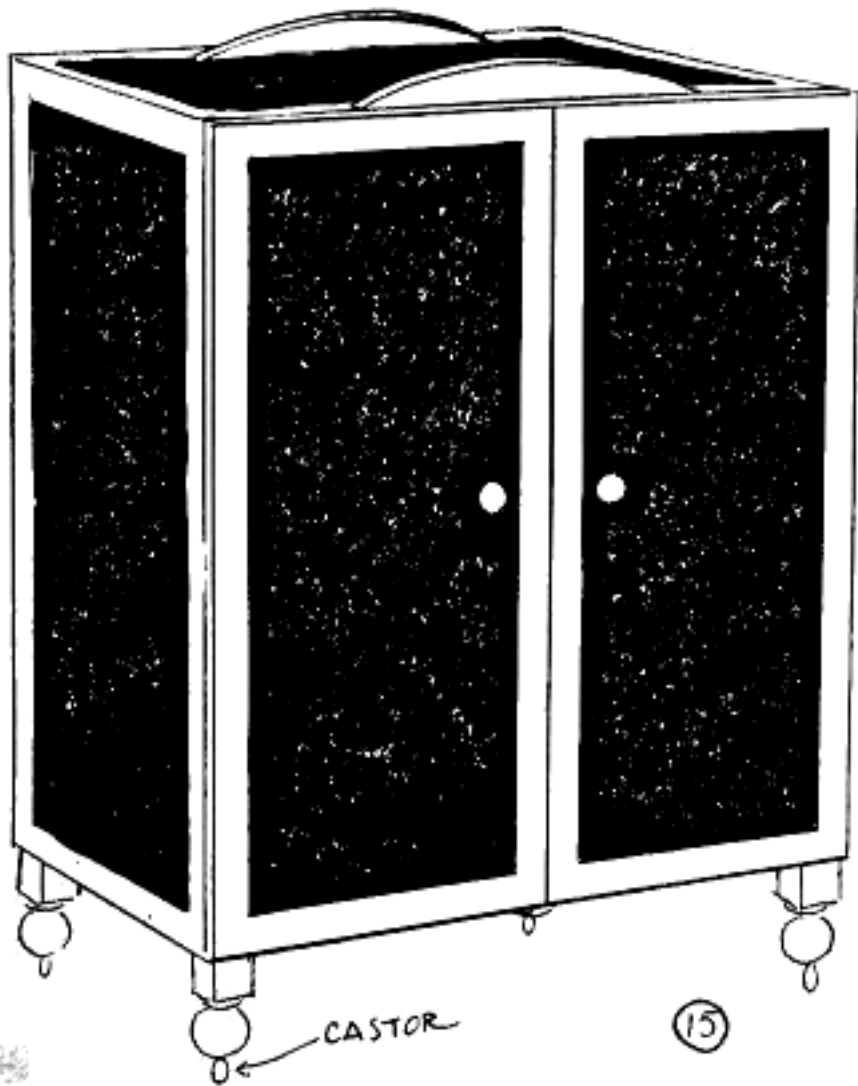
The "Mystery of the Dancing Girls" is especially valuable for the able magician because it is so easily adaptable where you are working with a number of people. It can be easily enlarged to handle up to a dozen people if necessary, though six is the customary number.

The "Mystery of the Dancing Girls" works out especially nicely for Christmas Entertainments, where various characters are to be magically produced - or in a Fashion Show for the production of various models - or - in a musical production for producing dancing girls. While the cabinet may seem bulky you will find many places where this type cabinet will be very welcome.

Some time ago when I was producing at one of the prominent moving picture houses in Chicago where Al Short and his orchestra were giving a series of presentations of various countries around the world, I had the stage carpenter build me a cabinet so that I could produce six dancing girls. The presentation was "India". Ollie Thomas, eminent saxophonist, was cast for the part of the magician. He was to play the part of the Hindu magician and produce the girls from the cabinet.

It was my first production for Short and when he saw the cabinet under construction and the method I was using for the production of the girls he was rather dubious as to whether anyone would be mystified or not and as to whether he had made a mistake in getting me to produce a feature number for him. However, he let the work go on. After the first performance, the manager of the theatre came back of the stage and complimented Short on the novel production of the girls. "But of course," he said, "I knew where the girls came from, as they came up through a trap door in the stage."

Short came and told me later about the incident and said, "That's enough, Tarbell, from now on you can do as you please and no questions asked. When you can fool the manager and make him think we can cut trap doors in a stage six feet thick in concrete, that's enough to convince me the illusion is good." And Al Short never questioned me again on any illusion I ever produced for him.



EFFECT:

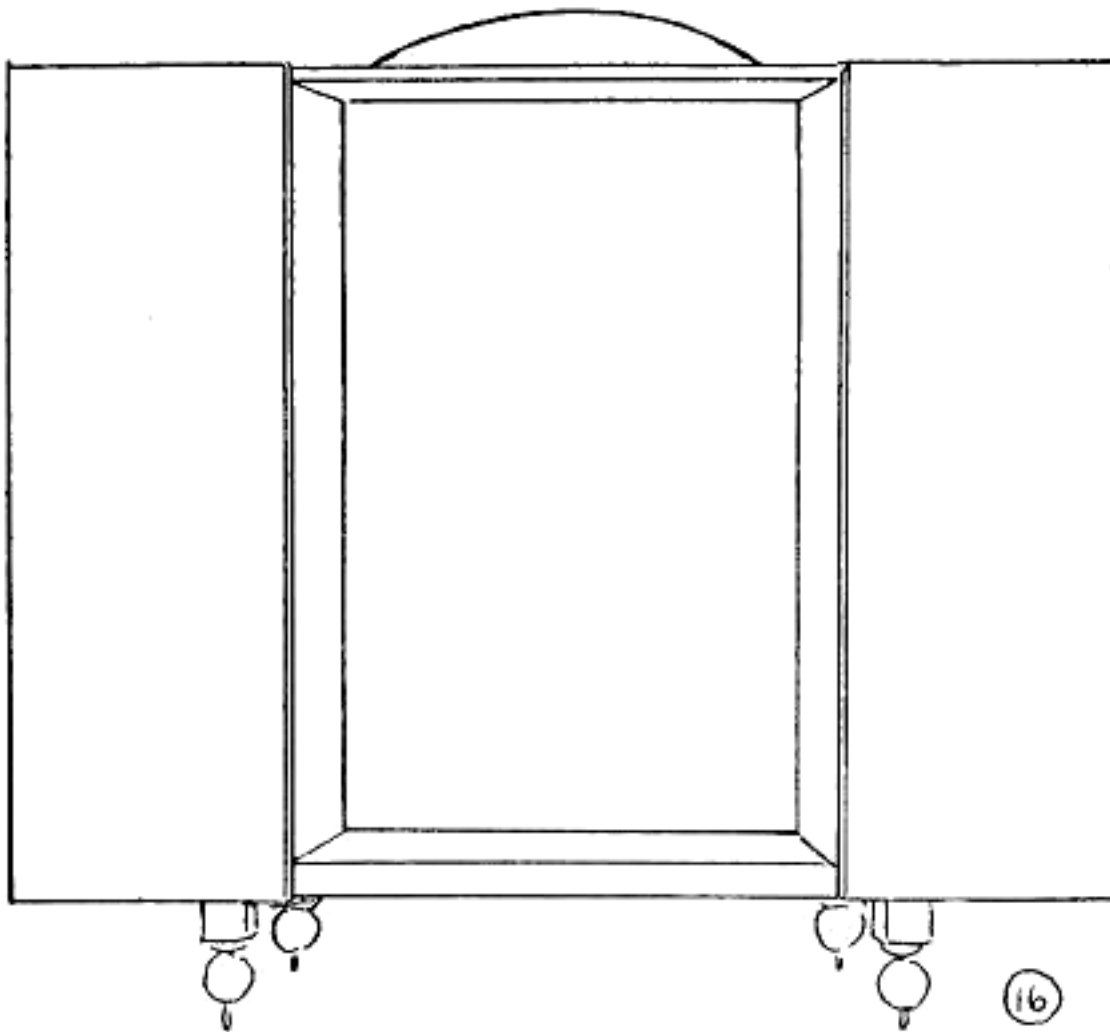
A black cabinet trimmed with gold or decorated in modernistic style, is freely shown by turning it around and opening the front and back doors to show it empty. The doors are closed and then the front doors are opened again. Six dancing girls fill the cabinet and step out of the cabinet two by two and into their dance. Or if desired the girls can be produced two at a time until the six have been produced.

PARAPHERNALIA:

1 -- A special cabinet to conceal six girls.

2 -- Six dancing girls.

(55-7)



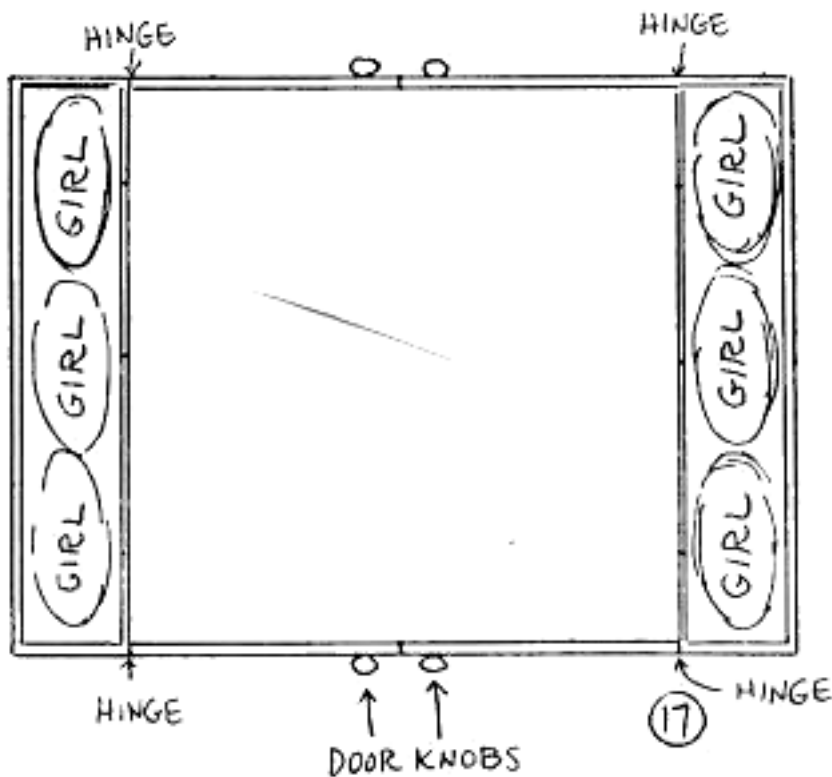
PREPARATION:

THE CABINET:

Fig. 15 shows the general appearance of the cabinet. It is about 5 1/2 feet long, 3 1/2 feet wide and 6 feet tall. There are two doors in front and two doors in the rear. They open out as shown in Fig. 16.

An ingenious principle is used to make the cabinet hold six girls and yet seem empty and without trickery.

(16)



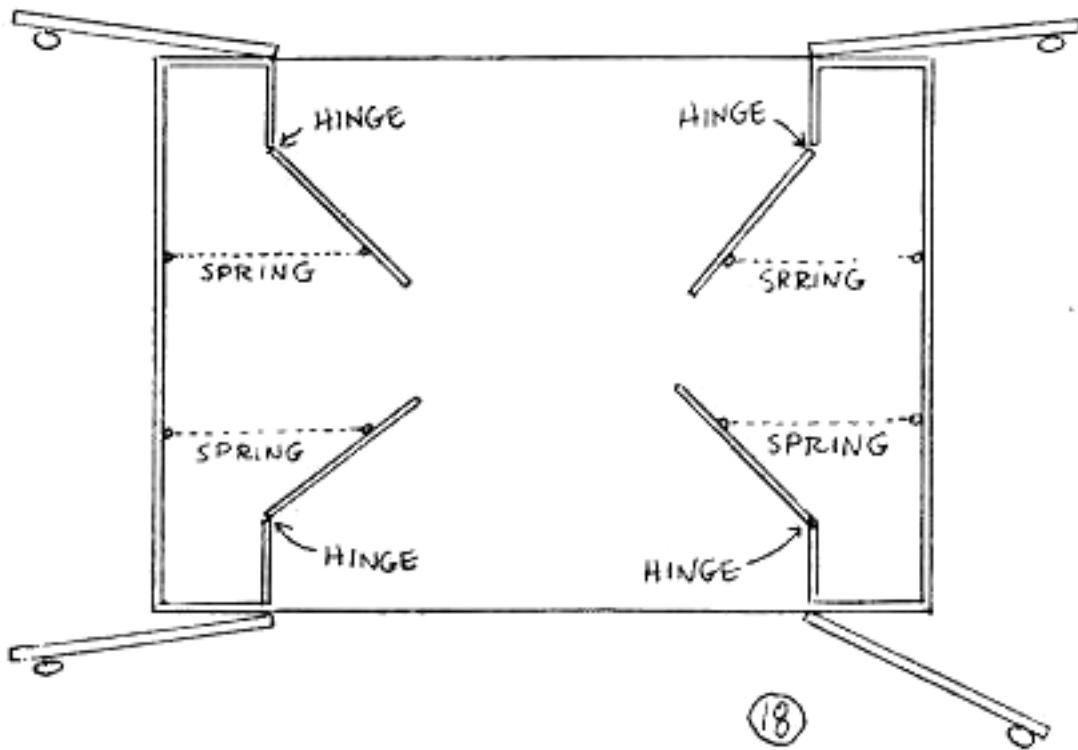
The girls are concealed in two small compartments, one on each end of cabinet. Each compartment holds three girls. Fig. 17. The compartments are about 9 inches wide. Each compartment has two doors, each held shut by a spring attached from door to side of cabinet.

(17)

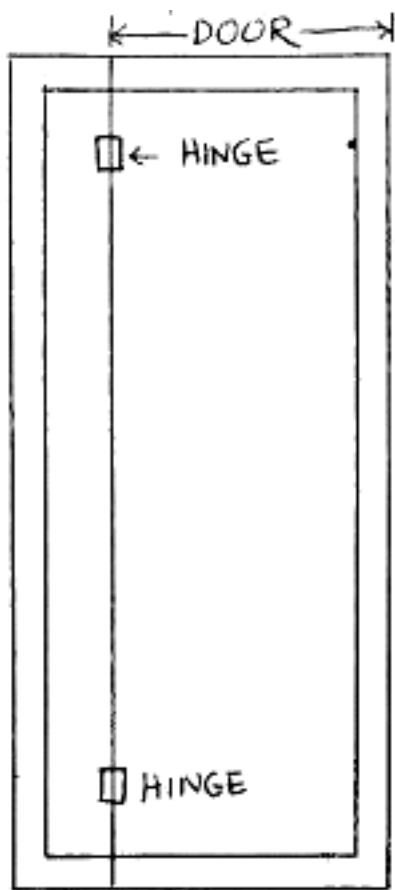
Fig. 18.

The doors open out into the cabinet and the springs pull them closed again.

The doors to the cabinet are tricked in an illusionary way. Apparently each opens all the way to the end of the cabinet, but in reality they open only within about eleven inches of the end of the cabinet.



18



19

Fig. 19 shows a door and where the hinges are placed. The gold two inch trimming around the door does not stop with the side of door hinged to cabinet, but continues over to the edge of cabinet. The hinges are hidden beneath the cloth covering on door. To audience door hinges to edge of cabinet.

When doors are open, apparently to sides of cabinet, the audience can look through the inside of cabinet and see that it is empty. The inside of cabinet is painted black. The cabinet seems empty but yet it has contained already within it six girls.

TO PERFORM:

Three girls are in one compartment and three in the other. The cabinet is wheeled forward and revolved entirely around. Cabinet is placed in position and front doors opened. Performer then enters cabinet and pushes open the back doors, showing cabinet empty. He closes rear doors and, coming to front, closes the front ones.

The moment front doors are closed, he gives signal and girls come from compartments into the cabinet proper, the inner doors swing back into place.



They stand two abreast and face the front. They stand so as to apparently fill the cabinet.

The front doors are thrown open, Fig. 20, showing the cabinet filled with girls.

Then they step out two by two and into their dance.

NOTE:

Such a cabinet holds remarkable possibilities for many occasions. Imagine the production possible with many folding articles within the secret compartments. These folded articles could be brought from their concealment and opened into the cabinet proper. This nicely affords three or four big successful productions - one after the other.

To add variety for some church Christmas entertainment, Santa Claus could show cabinet empty and produce two brownies with boxes of candy and then two more

brownies with
presents and such.

Cabinet could be used
to produce from four
to six tableaux with
a new person posing
in each.

Special curtains
could be concealed in
compartments and hung
on back doors and
unrolled to form
background. Each
person produced in
tableau could be
dressed to fit it.
Then after tableau
person posing could
step out while doors
are closed and
another scene and
person is produced.

Scores of magicians
will welcome this
production for
special occasions,
adapting the
production to fit the
occasion.

(55-9)

THE DOLL HOUSE ILLUSION

I am now about to reveal to you an illusion that has been very popular with many of our leading magicians. It was originated and first introduced, I believe, by Fred Culpitt, a clever English magician.

It has a particular advantage in being a self-contained novelty and enables the performer to present it in story form.

EFFECT:

The performer shows a miniature house on a table. The front is opened and inside of the house shown with its various furnishings. The furnishings are removed, house shown empty and doors forming front of house closed again. Performer states that this is a doll's house and that a doll lives in it. Then suddenly the roof spreads open and lo! - up jumps a live doll! Performer aids girl assistant to floor. The sudden appearance of a grown person in such a small house is indeed a surprise.

PARAPHERNALIA:

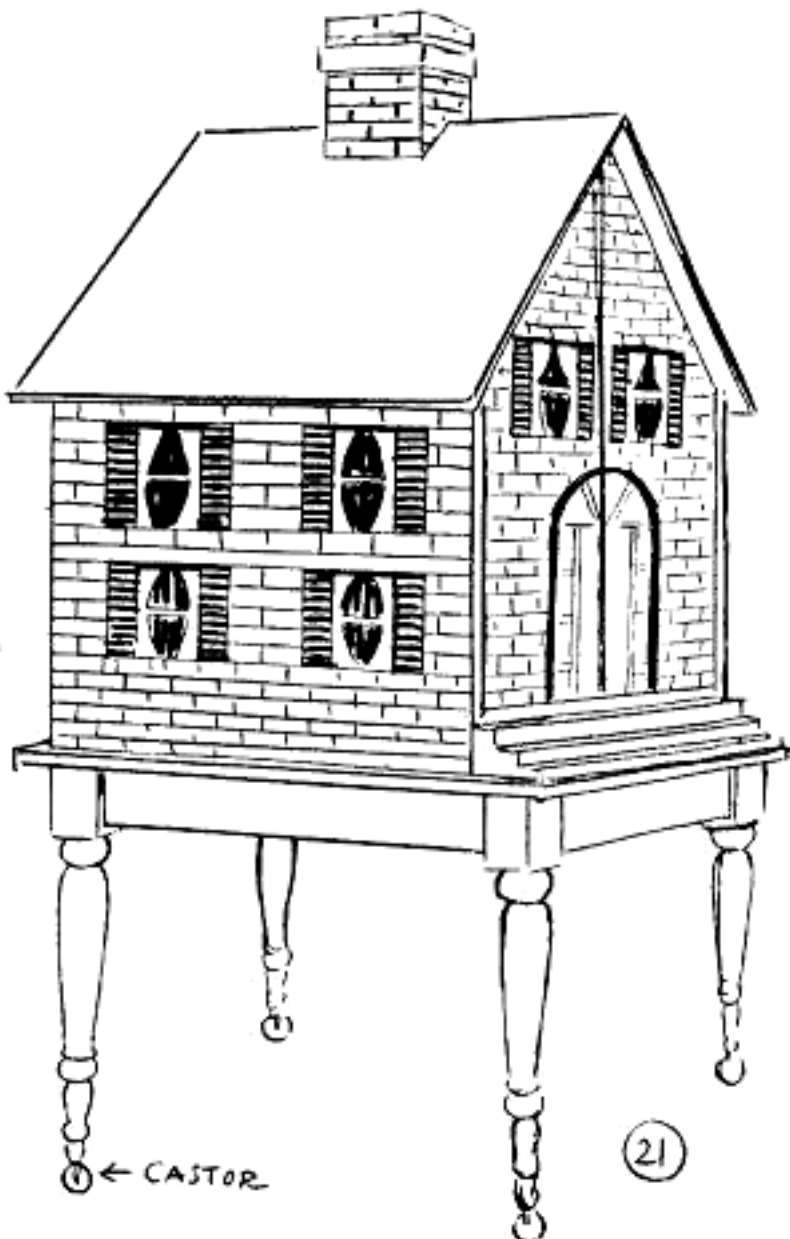
- 1 -- The doll house on table.
- 2 -- Furnishings for the doll house.
- 3 -- Girl assistant dressed as doll.

PREPARATION:

THE DOLL HOUSE:

Fig. 21 shows the general appearance of the doll house on the table. The table has a double purpose. One is that it supports the doll house up off the floor and the next is that it helps to conceal the girl. To conceal a girl in such a small house would be difficult, but to conceal part of her in the doll house and part in the table solves the difficulty of concealment.

(55-10)



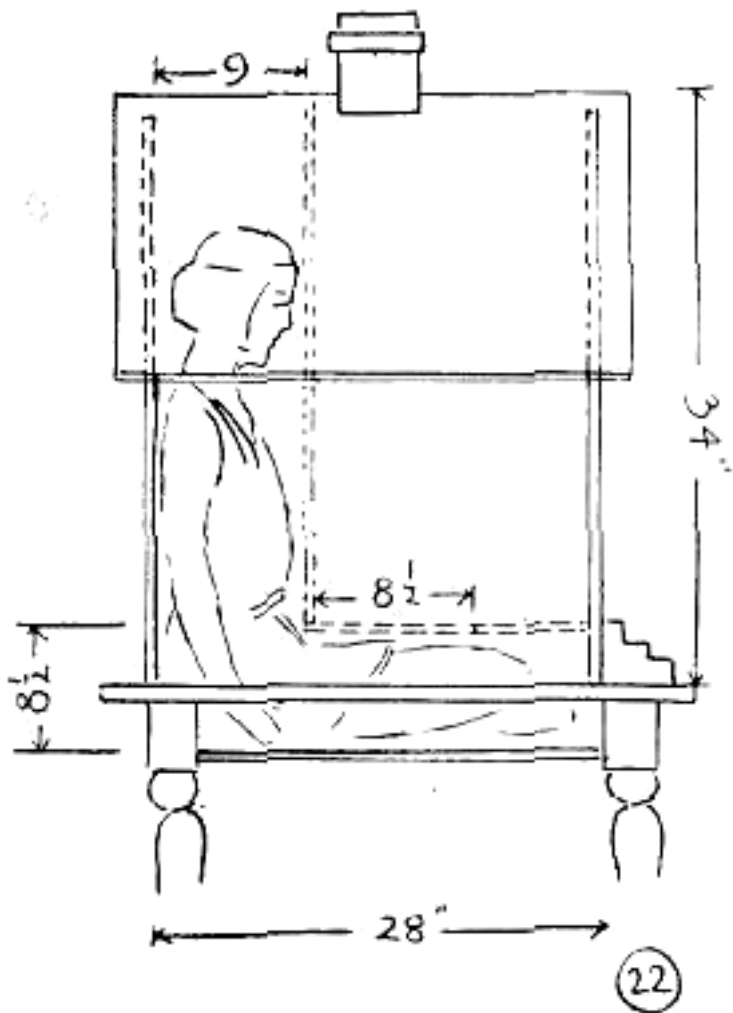
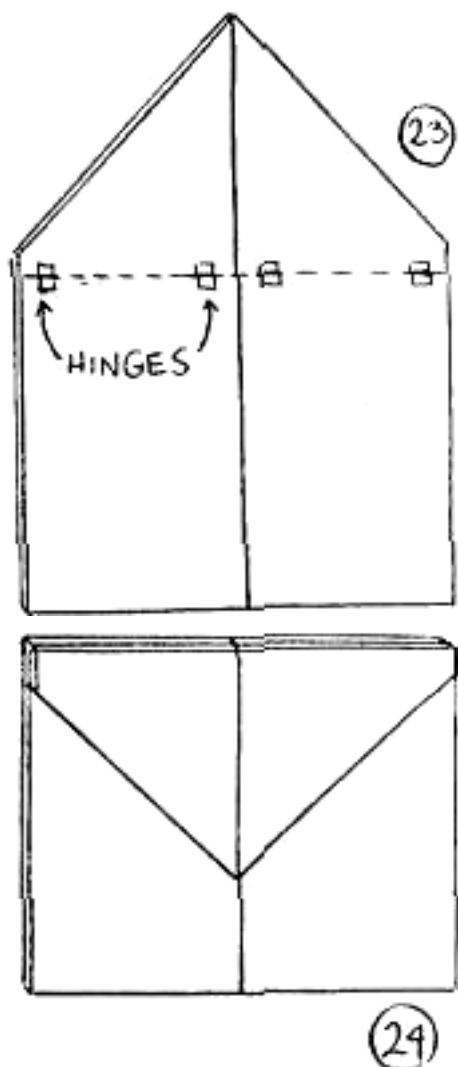


Fig. 22 shows how girl is concealed. The steps also help to carry on the illusion. The lower floor of the house is on the level with top of upper step. The upstairs floor is held in place with four pegs. When the doors making up the front of house are opened, Fig. 24, the audience thinks they see clear to the back of the house. In reality they do not. They see a false partition which hides the girl, Fig. 22.



The inside of the house is lined with fancy varicolored cretonne which fools the eye on depth. There are nine inches of space between the back of house and the partition. There is a space of 8 1/2 inches between floor of house and bottom floor of table top. This holds an assistant nicely as in Fig. 22.

The partition in front of the girl is in reality two doors which hinge to sides of house. These doors also hinge so as to occupy less space when opened. Figs. 23 and 24.

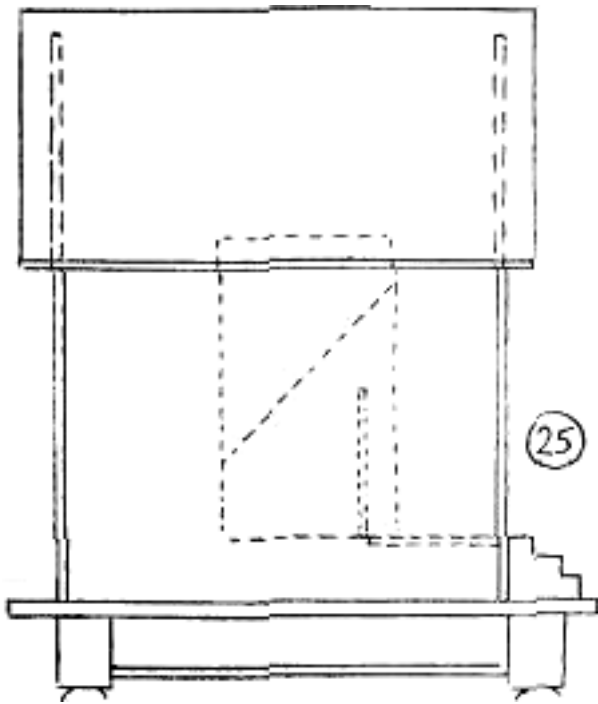


Fig. 25 shows how doors fold up against side of box.

The floor of house also has a panel in rear which folds up. This panel enables girl to get in and out of compartment easier. This opens up after partition doors are swung open against sides of doll house.

(55-11)

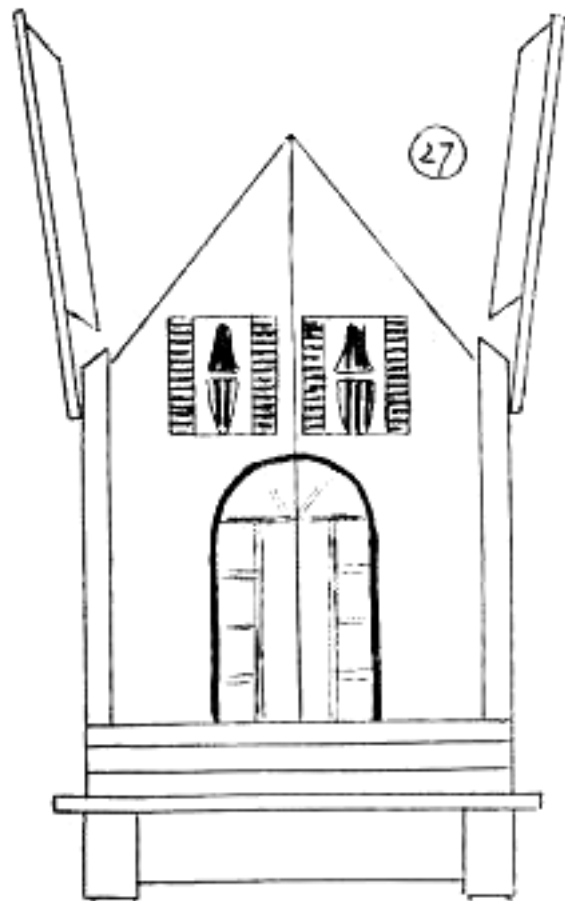
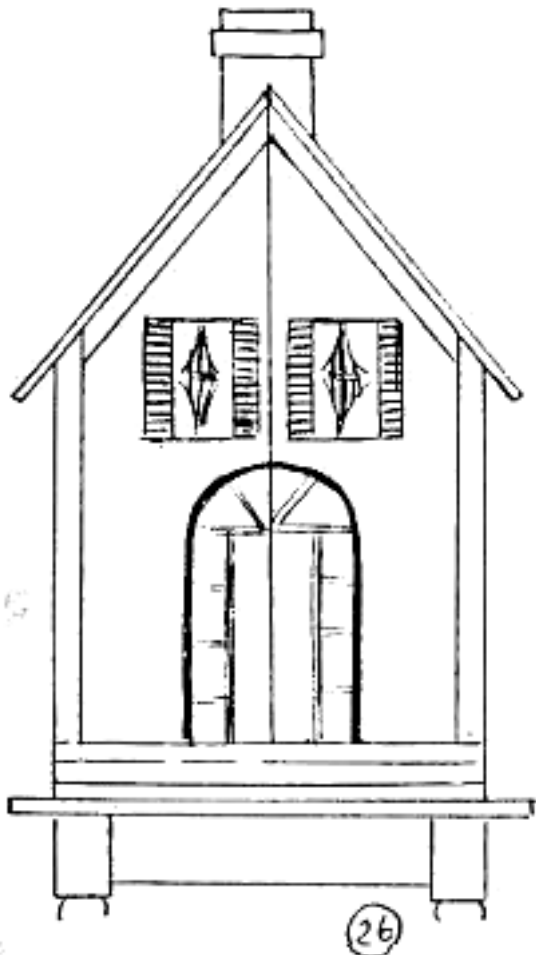
The roof consists of two parts, each hinging to a side of house. There are special cleats or boards on inner side of roof to fit into front and rear sides of house. Figs. 26 and 27.

A wooden chimney with groove at bottom rests on the house. It can be slid back and forth.

The side of roof has a special cleat on inside to push partition in place against when concealing girl.

The furniture for the house consists of a miniature bedroom set for the upstairs and a living room set for the downstairs. These can be made to order or purchased in the doll department of a department store.

The legs of table are on castors.



TO PERFORM:

Girl assistant is dressed as a doll and concealed in the special compartment, Fig. 22. The rear panel of floor is folded down on her lap and the two doors of partition pushed into place to represent back of the doll house.

The upper floor is put into place and furniture arranged properly. The roof is closed and chimney adjusted into place. The front doors are closed.

The doll house on table is rolled forward, revolved and placed with front of house to audience. Fig. 21.

"This is a doll's house. A house where a doll lives. It has windows and doors and a chimney that slides back and forth."

Slide chimney back and forth on the roof. This adds a comedy touch.

"Would you like to see where Dolly lives? We'll open the front of the house."

Open up the front doors wide showing inside of house. Fig. 28.

"There is an upstairs and downstairs. A bed. a bureau and a rocking chair."

Remove articles one at a time, show and place on tray held by assistant to receive them.

"Here is a sofa and a piano."

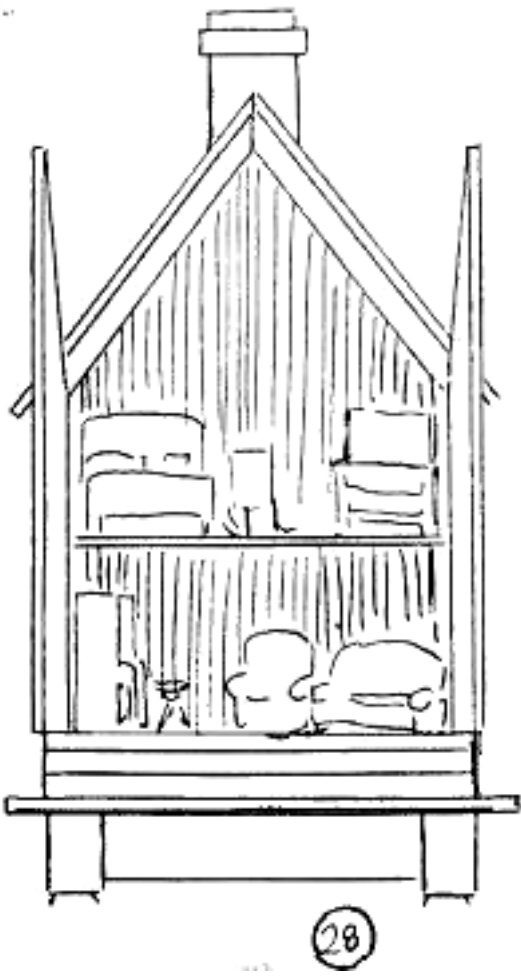
Continue removing articles and naming each as you do so.

Remove the upper floor of house and the pegs supporting same. Give to assistant.

"So there's the house emptied from cellar to garret."

Close the front door.

(55-12)



"And yet a dolly lives in the house. Some say she goes in and out the chimney."

Remove chimney and show opening in same. Give to assistant.

"Let's see if Dolly is at home."

Knock on the side of the house.

NOTE:

Immediately after house is emptied and front doors are closed, the girl assistant pushes down the upper part of two partition doors, then pushes doors against the sides of the house. She raises the panel of floor. She pulls herself up a bit so at signal of knock on house she can suddenly appear.

Suddenly the roof opens up and up jumps Miss Dolly. Fig. 29.

If desired she can have an open brightly colored parasol which she opens as she rises up.

Performer opens front doors and assists girl to the floor.

Assistant then pushes doll house back and revolves it so audience does not get too careful a view inside house.

Doll house can be performed without extra assistant, in which case performer places things on a nearby stand or chair. At close of illusion as girl is produced and steps down, performer pushes front doors shut.

A chair placed in front of house at proper moment helps in allowing assistant to step down onto floor, although in most cases the jump to floor assisted by performer is easy to make gracefully.

In this lesson you have been shown three self-contained methods of concealing from one to six girls. As you continue in illusions you find other methods of concealment.

Given these various principles, I want you to vary them into original presentations and illusions of your own. Later on, in "The Chinaman, The Ghost and The Cat", I will show you how I take an illusion principle and build a pantomime act around it.



Hurlan Tarbell

TARBELL SYSTEM, INCORPORATED. Chicago.

LESSON 56

In this lesson we will discuss illusions dealing with placing a girl assistant in a small compartment and yet being able to run many swords or bars through the box at various angles apparently piercing the girl, yet at the end she is shown unharmed. Also the illusion of "Sawing a Woman in Half" in a simplified version. Watch for this -you'll find it very interesting.

(55-13)

Have YOU ever witnessed that ever fascinating, gripping Magic Illusion, commonly known as "The Human Sworn Stabbing Illusion"?

Have YOU ever seen a magician have a beautiful young lady step into a basket or box—then proceed to jab a long sword or knife into the basket—and then just when the audience is in the imaginary tragedy of this act—see the magician smile, lift the lid of the basket or the door of the box—lo, to your astonishment—THERE STOOD THE YOUNG LADY ALL WHOLE, UNMARKED, UNSCARRED AND SMILING?

This Magic Illusion has long been a fascinating illusion to the magic profession and to the general public.

This is one of the great feats of the Hindu Fakir. People who have sojourned in foreign lands have been held spellbound watching the Hindu Fakir perform this weird feat.

Scores of magicians have tried to duplicate the illusion in some form. While some have been successful yet many have tried and have been unsuccessful because their showmanship was not properly perfected.

I am now going to reveal to YOU the secret of this illusion. BUT—before I do this, there are certain things that I deem it very important to enlighten you upon—certain important facts and dangers that I want to WARN you about.

Popular in magic are effects in which a human being is apparently run through with swords, iron bars, etc., or sawed in half, cut in half or burned. Yet at the finish said human comes forth unharmed and smiling. An illusion of this kind will stand considerable publicity.

There is always a line between something gruesome and the spectacular and the psychology of an audience always has to be taken into consideration in the presentation of anything that would harm a human on the stage. The magician can do many spectacular things providing the assistant is not visible and no blood shows.

Some performers in their effort to do something spectacular go beyond the part of good showmanship and create discomfort in the audience instead of attractive interest. An illusion that makes an audience shudder and turn away is not good and should be avoided, but one that holds pleasant interest even though thrilling to the end is good.

You must never forget the psychological effect of an illusion on your audience for you are there to PLEASE and gain favor.

A girl can be placed inside a box and swords pierced through her apparently, with good effect, but let a performer jab needles, pins, nails, daggers, etc., into his or someone else's flesh visibly and there is a different reaction. Some

performers think that piercing their arms with nails, etc., is good showmanship and gains them favor, when in reality it turns people and business away. Then they wonder why they are not box office attractions.

In sawing a woman in half if the saw was actually seen to penetrate a woman's body the effect would be horrifying. But if the imagination only is played on and the audience only think it is being done but cannot really see it, there is a different form of reaction.

It was my original intention to introduce a burning illusion in the course, but since there is so much danger with fire and difficulty to get bookings with fire acts, I have avoided same and substituted with better material. There have been so many disastrous theatrical fires that managers are more or less afraid of spectacular fire acts.

There are many things to consider in teaching. My big idea is for your success, and I give you material which I believe will make you the most successful. Sometimes students want to waste time with a lot of impossible stuff and they have to have several hard bumps before they wake up and learn from those with experience. It isn't always a case of what a student wants, but what he needs. There is a difference.

In describing the various illusions in the lesson, the sizes are approximate. There is a chance for plenty of useful experimenting in illusion cabinets of this type. Assistants vary in size and what might be a giant size for one may be a pigmy size for another. I figure the average.

There is no absolute reason why the holes for the penetration of swords, etc., cannot be varied or changed to get even better effect. In illusions I endeavor to leave plenty of room for INDIVIDUALITY. This gives you a chance to step up a few notches above your brother performers.

The secret of penetrative illusions resolves itself around being able to run swords, etc., through a box or whatever it may be without penetrating the subject. Every sword must miss the subject.

Because of the shape of the human body it can be twisted about and bent to various positions. The body is wide in some places and narrow in others. The body is narrower looking at it from the side than from front and back. Knowing these things, by using ingenuity, it is surprising the remarkable effects that can be created.

The assistant is placed in position originally farthest away perhaps than will be when covered from eyes of audience. The position that audience sees just before box, for instance, is closed is the one they keep in mind.

The old Indian Basket trick is one of the forerunners of the penetrative illusions, and even it is still popular in the programs of many modern day magicians. A magic trick is never too old when presented with the right showmanship. Always remember that.

THE SWORD BOX

EFFECT:

A box is shown mounted on four turned legs with castors. The top lid is raised and front door opened. Girl assistant steps into the box and then sits down in it.

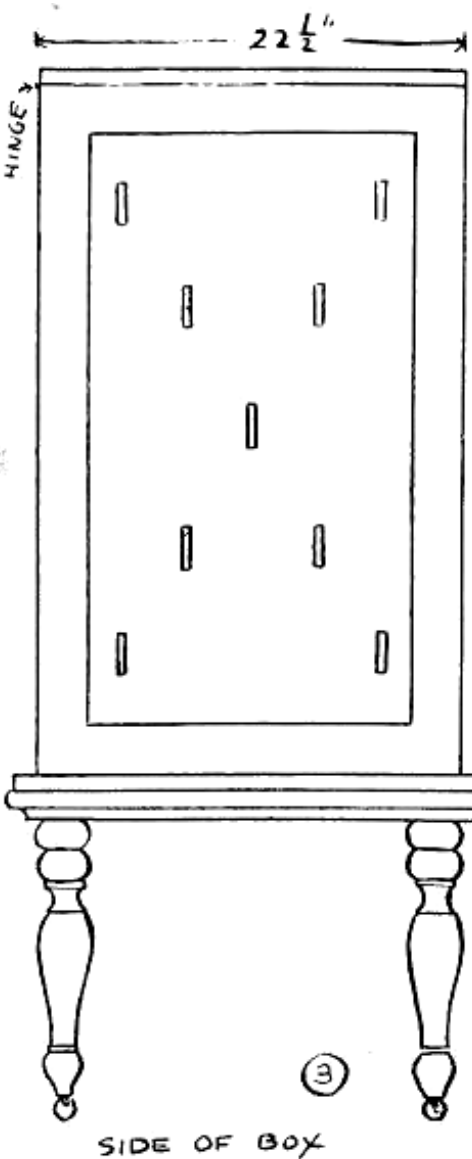
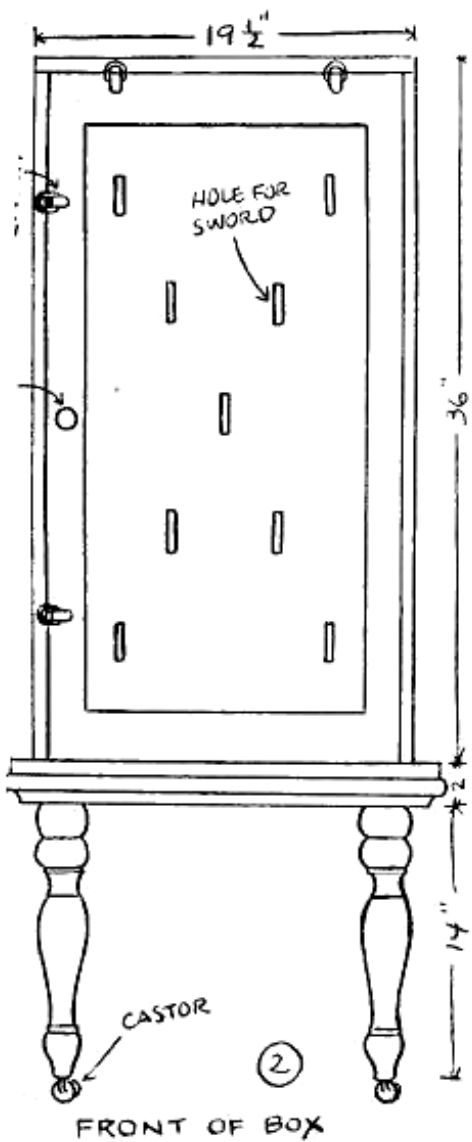
The lid is pulled down. The girl practically fills the box. The front door is closed and attention called to a number of holes on each side of the box. A bunch of swords are shown and run through the box apparently penetrating the girl. The swords are run through the box at every possible angle. Even a spear is run down through a hole in the center of the top and bottom of box.

Finally the swords and spear are removed. The door and lid are opened and the girl steps from box unharmed.

PARAPHERNALIA:

1 -- A Sword Box.

2 -- From Twelve to Thirty-six Swords, or even more. An imitation Japanese sword made of wood would answer the purpose. Fig. 1.



PREPARATION:

THE SWORD BOX:

The box measures about 19 1/2 x 22 1/2 x 36 inches (outside measurements). Fig. 2 shows a front view of the box and Fig. 3 a side view. Some boxes are 18 x 18 x 35 inches (inside measurements), but I allowed 3 inches extra from front to back.

The sides and top are paneled and are best if built of three-ply wood through which slots or holes are cut, through which the swords can be run. For temporary use wallboard can be used. The bottom of box should be made of 3/4 inch wood nailed to framework beneath. A moulding can be placed around framework for finish.

The box is fastened together with loose pin hinges as already described in a former lesson. The box is likewise fastened to bottom framework. The lid is hinged at the back so as to swing upwards and the front door is hinged so as to swing outwards.

Fig. 4 gives a cross section of box looking from above downward and showing front door slightly open.

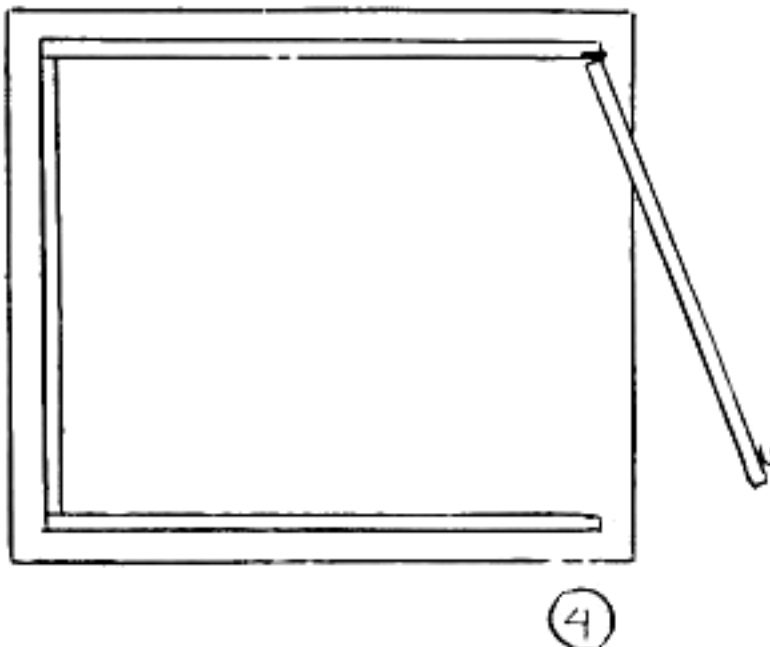
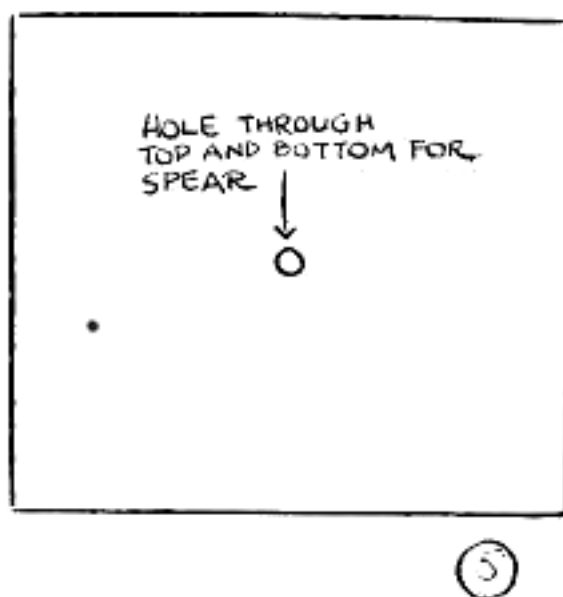


Fig. 5 shows the lid with a hole through center through which spear can be inserted. A similar hole is in bottom of box.



The legs are of turned wood and have pine nipples inserted in the top, which engage with floor flanges screwed to the bottom of the box. Or, if desired, legs could be made of plain pine stock.

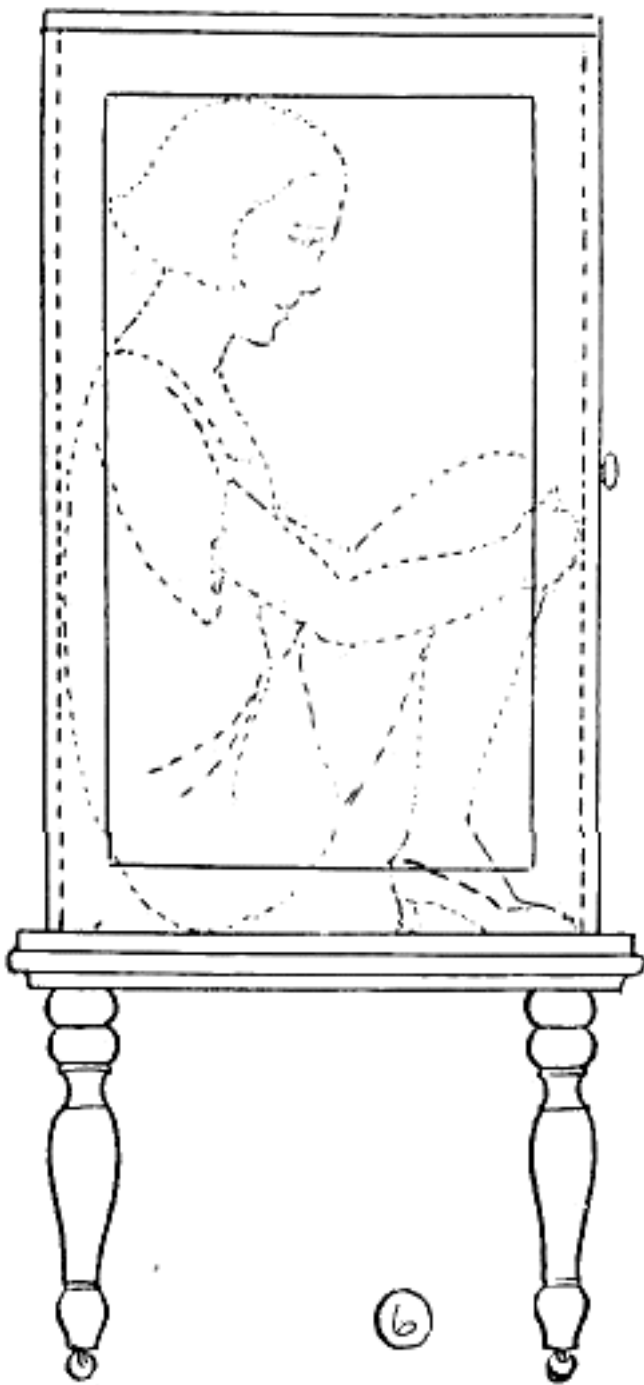
The holes for swords should be about two inches long. While one arrangement is given in illustrations, yet more holes can be added or arrangement changed.

The box and platform should be nicely decorated so as to make a pleasing appearance.

TO PERFORM:

The sword box is in readiness. Nearby on a table are the swords, or these may be held by an assistant.

The box is brought forward. The lid is opened and also the front door. The girl assistant, dressed so as not to have an excess amount of skirt or loose clothes to interfere with swords, comes forward and stands up in box facing the audience.



She then sits down in box as in Fig. 6 (side view). The main idea, too, is to apparently fill the box. You close the lid and then the front door. Secure in place with the catches so door will not accidentally open. Revolve cabinet showing all sides.

Stop cabinet so side of same is facing audience, Fig. 6.

Take a sword and run it suddenly through the center slot. Girl inside cabinet can have a small flashlight concealed in her clothing if necessary, and when sword enters can direct it through to the center hole in opposite side.

Swords are thrust through the box from all sides until swords stick out from practically all directions.

You should practice a routine and each of you know the routine that the swords will enter and go out of box and in the proper order. In this way assistant inside of box will know just what to expect and where to help direct sword for its exit.

Some of the swords will go through at angle and instead of going to the opposite side will exit through the right or left side. In this way you get effect and still miss body of girl assistant.

The spear finally is pushed down through the hole in lid down in front of girl's body, between her legs and through the hole in bottom of box.

The box is revolved to show swords piercing all sides. Fig. 7.

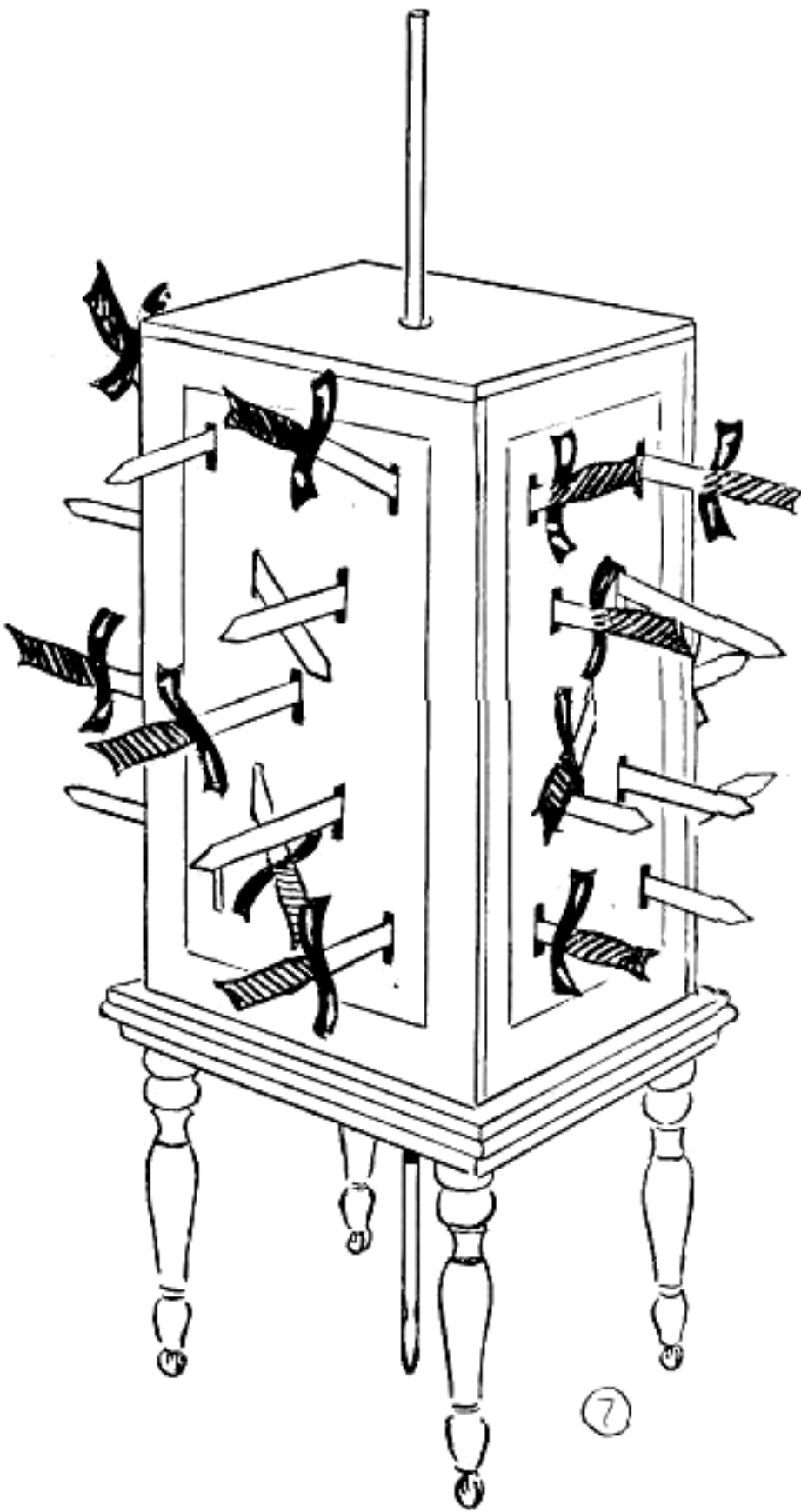
Finally spear is removed then the swords. Box is brought to position then with front door towards audience. The front door is opened, also the lid, and girl stands up in box. She is assisted from box.

The sword illusion is very easy to perform, yet effective. But you must routine it so as to speed up piercing of box with the swords. It is well to number each slot and each side so as to help build a mental picture for

the entrance and exit of each sword.

And do not forget showmanship.

(56-5)



THE PENETRATIVE STEEL BARS

EFFECT:

Assistant stands in box-like structure with holes or openings through the front and back. He apparently fills most of the box. The front door is closed. Twenty-seven iron bars are shown and are pushed through the various holes from front to back and back to front. It seems as though assistant is pierced many times. Box is revolved and steel bars withdrawn. Door is opened and assistant steps out unharmed.

PARAPHERNALIA:

- 1 -- The Penetrative Cabinet.
- 2 -- Twenty-seven steel or iron bars about a half inch in diameter and about three feet long. Or you can use wooden sticks.

THE CABINET:

The illustrations will show the construction very nicely. The cabinet would be well to be paneled and use three-ply lumber, or for temporary use wallboard. The sides should be held together with pin hinges or bolts and wing nuts and cabinet held to bottom in like manner. In this way cabinet can be easily taken apart for packing. The top consists of a lid which is hinged at rear and opens from the front. The front side of cabinet opens as a door. Twenty-seven holes are bored in the front side of cabinet and a like number in the rear, 3/8 to 3/4 inch in diameter. Fig. 8 gives a view of cabinet from the front and Fig. 9 a cross section from the side. Fig. 10 gives a cross section looking from above downward.

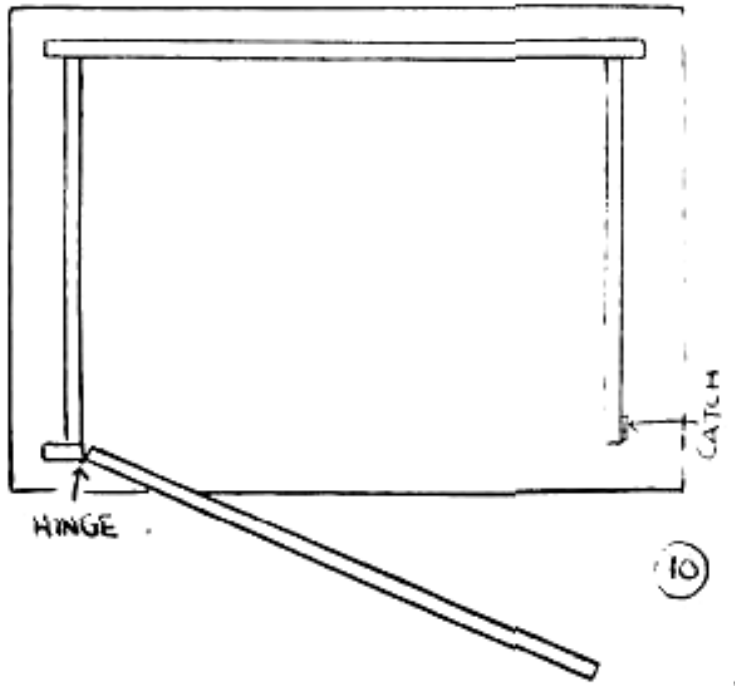
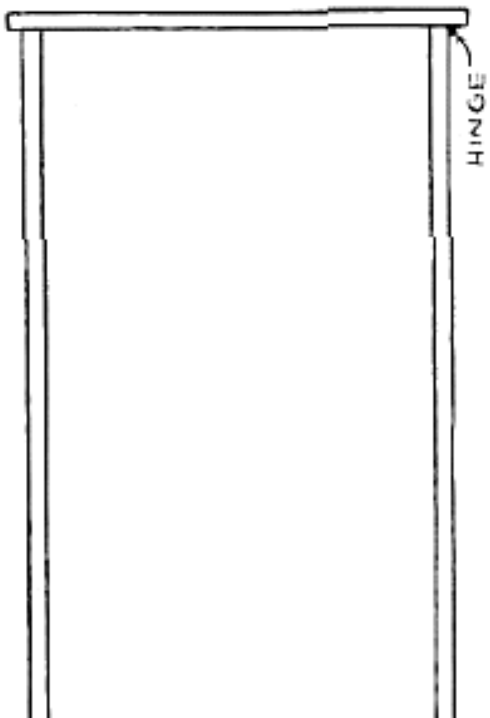
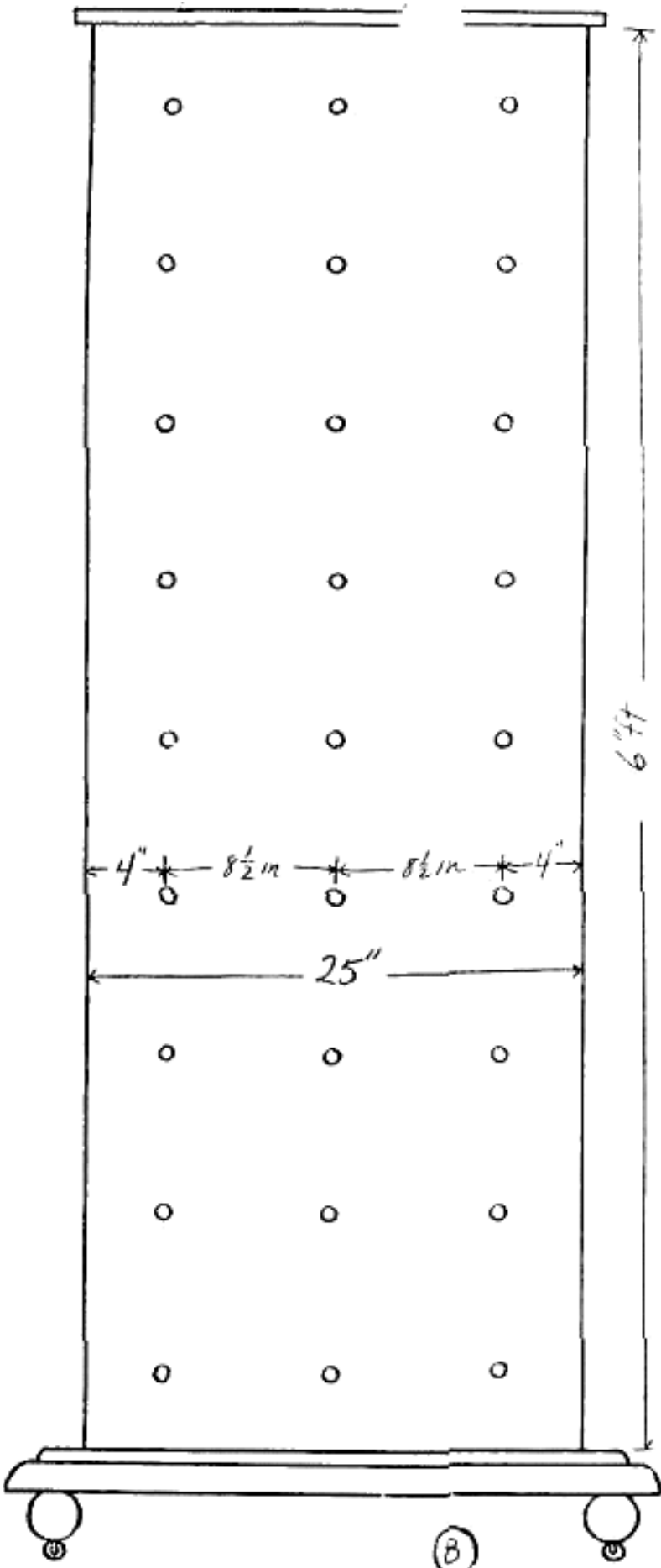
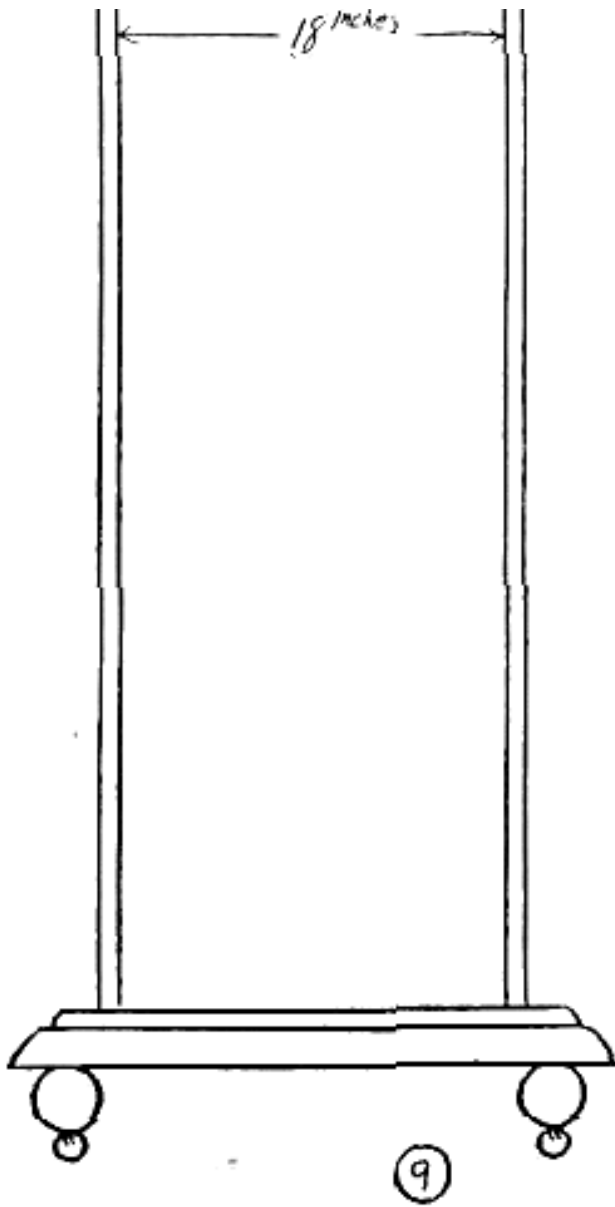


Fig. 8 gives dimensions. There should be about 8 1/2 inches between the center of each hole.

The front and back side are about 25 inches wide. The box proper to which they attach is only about 22 1/2 inches (outside measurements), being about 20 1/2 to 21 inches inside measurement. The reason of the extra width of door over box is so as to allow more room between



outside holes in door and the side edges of door thereby apparently bringing the two outer lines of holes near the center of box.

It is tricks like this that go into illusion building, so as to help perfect an illusion.

(56-6)

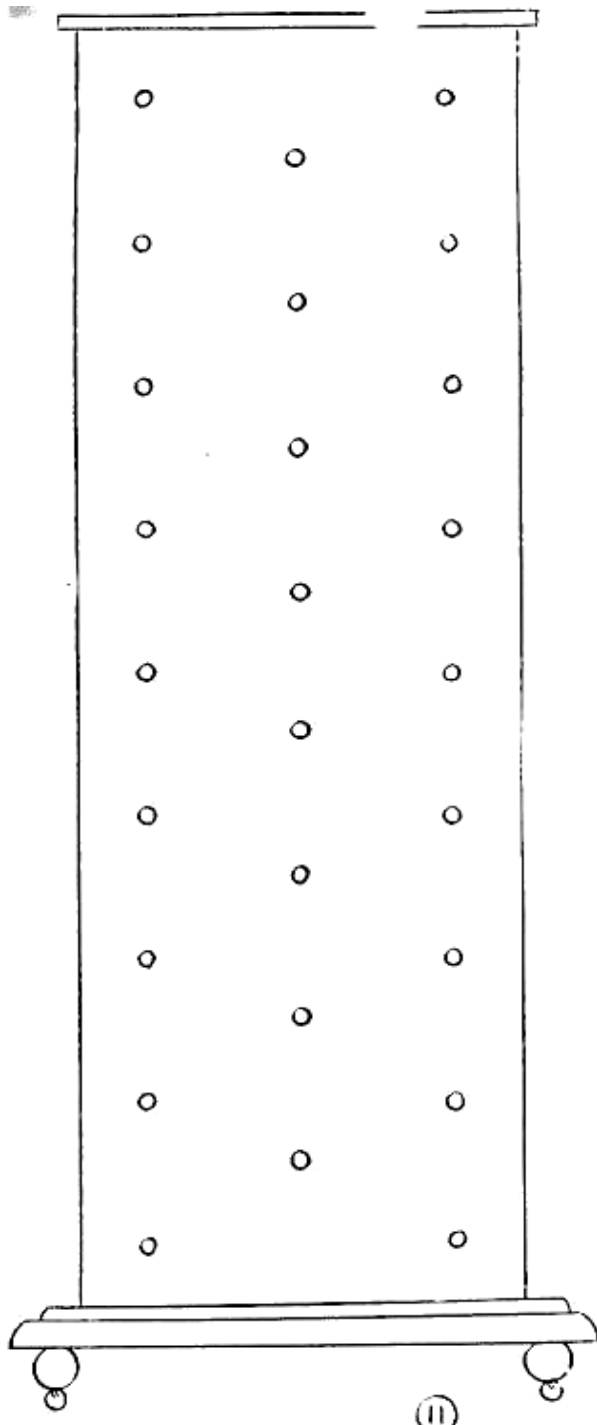
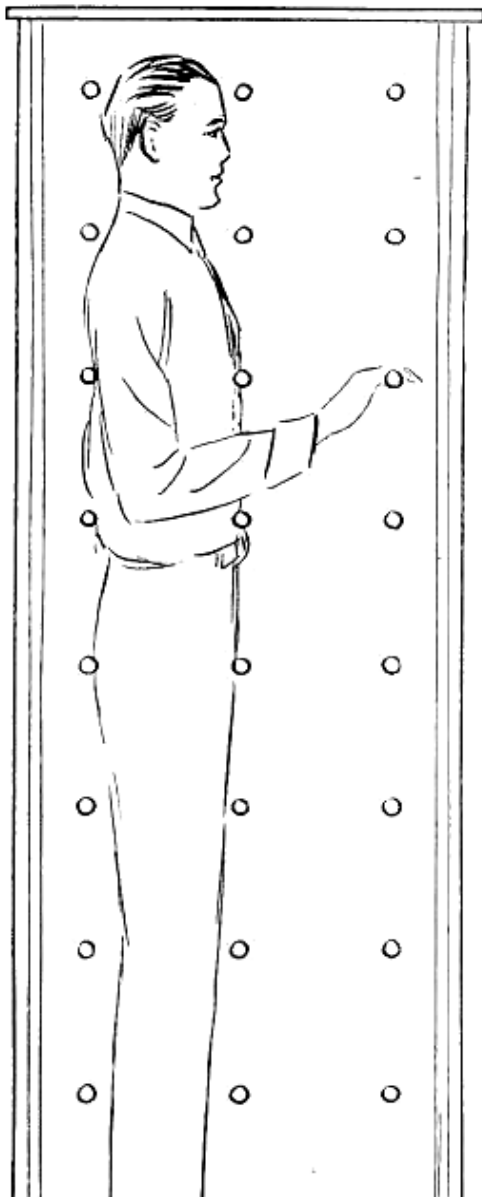
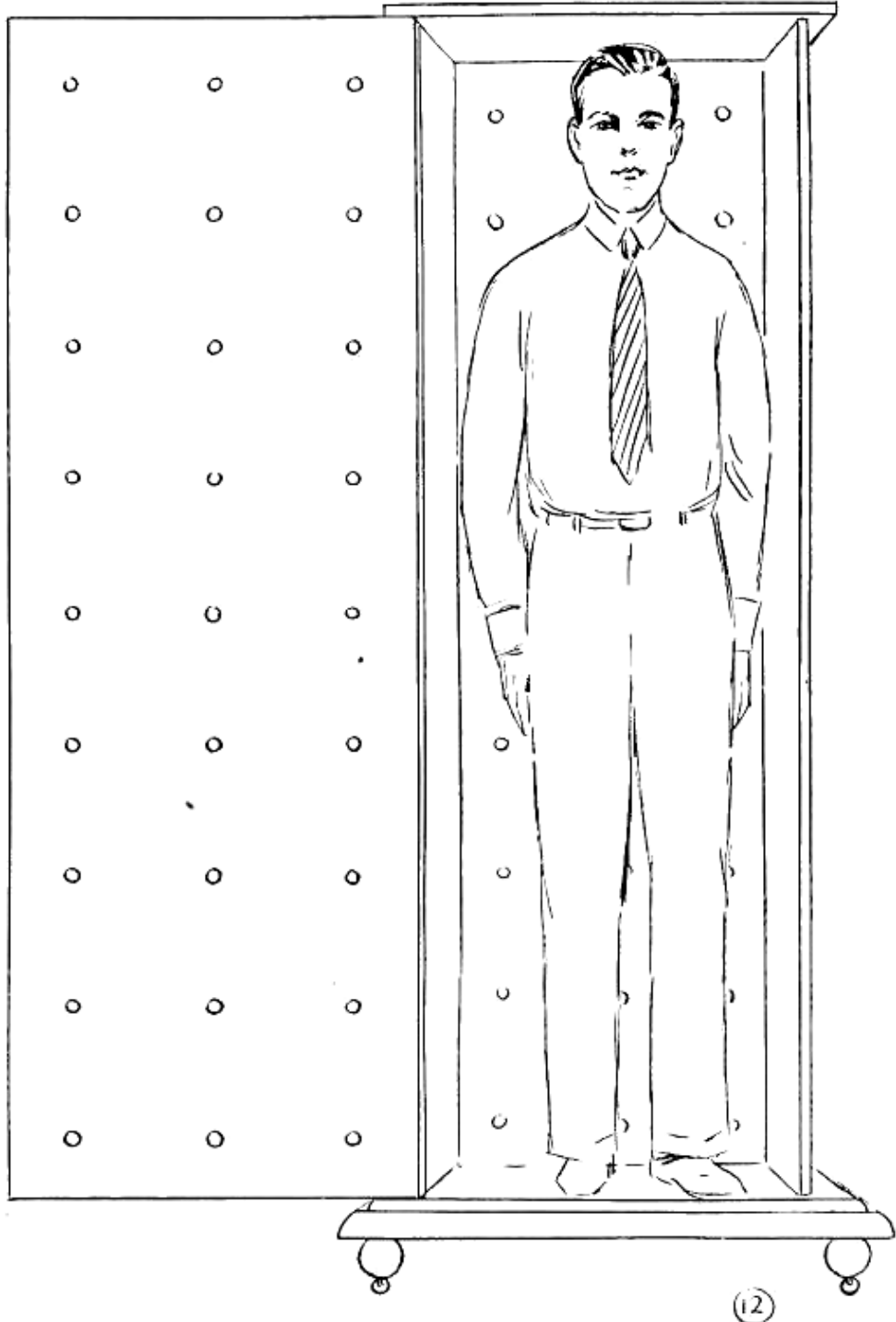


Fig. 11 shows a slightly different arrangement of the holes. In this arrangement there are 26 instead of 27. Either system is effective.

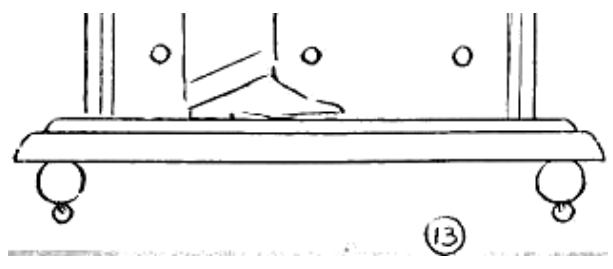
The cabinet should be nicely decorated so as to make it quite attractive.

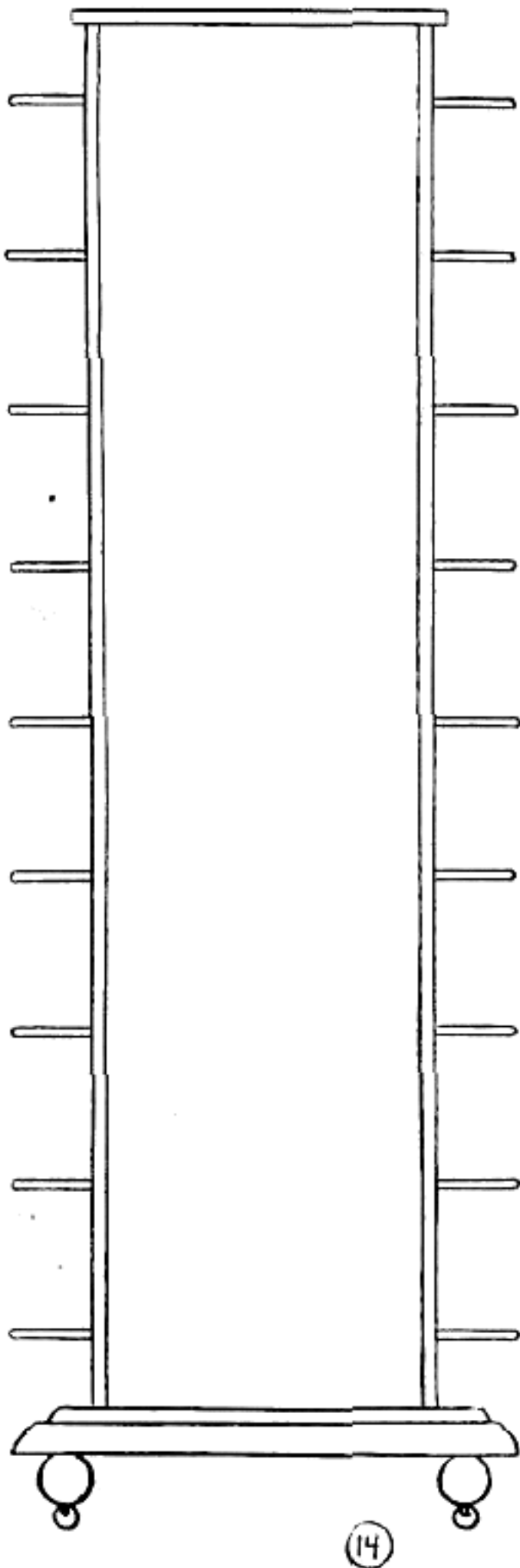


TO PERFORM:

When door is closed assistant turns with his side to front, Fig. 13. In this manner he can avoid the metal bars going through the cabinet. The body is much narrower from the side than the front. Bars are thrust in routine order through the holes from back to front and front to back. If you have another, so much the better, as one can stand on one side and the other on the other side. After a few bars have been pushed into cabinet up through central portion, apparently driving through upper body, the cabinet is turned with side to audience so audience can see bars entering one side and going out the other. Assistant inside box can help direct the bars.

The cabinet is brought forward. Door is opened. Assistant enters cabinet and stands facing audience. Fig. 12. In entering he should step in backwards and not allow himself to turn with his side to cabinet. He can have his side turned to audience away from cabinet but not in front of same. You must create the idea that performer practically fills the cabinet. There must be no side comparison. Performer himself must also be careful of this.





The door is closed and held tight by means of catch on side of box and on door. Door can be hooked. Just something so that door will not accidentally open.

Fig. 14 shows a side view of cabinet with bars showing front and back, and Fig. 15, another view of cabinet with bars showing.

After all bars are in cabinet, revolve the cabinet.

Then remove the bars as speedily as possible. When bars are removed, assistant inside turns with body facing front door as in Fig. 12. The door is opened, Fig. 12, and assistant steps from box unharmed. Close door, move cabinet back out of way.

Practice will enable you to pierce the box with bars very rapidly, which is essential so as not to slow down the illusion.

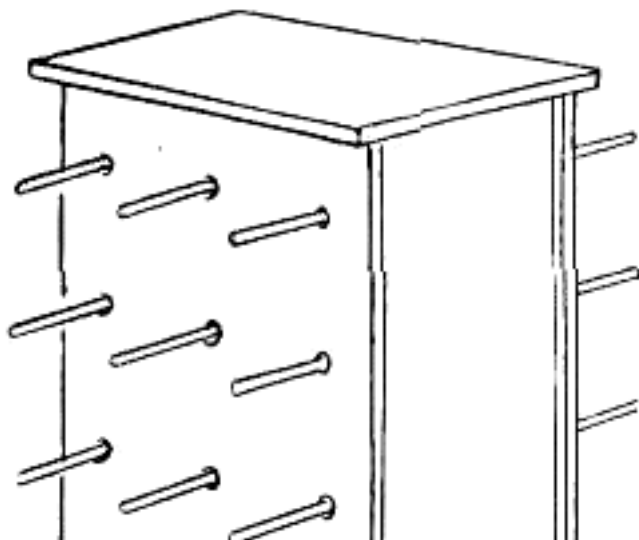
A girl assistant with tights and trunk with fancy upper garment can be used instead of male assistant if desired, in which case, cabinet can be built even smaller, depending on the size of the girl.

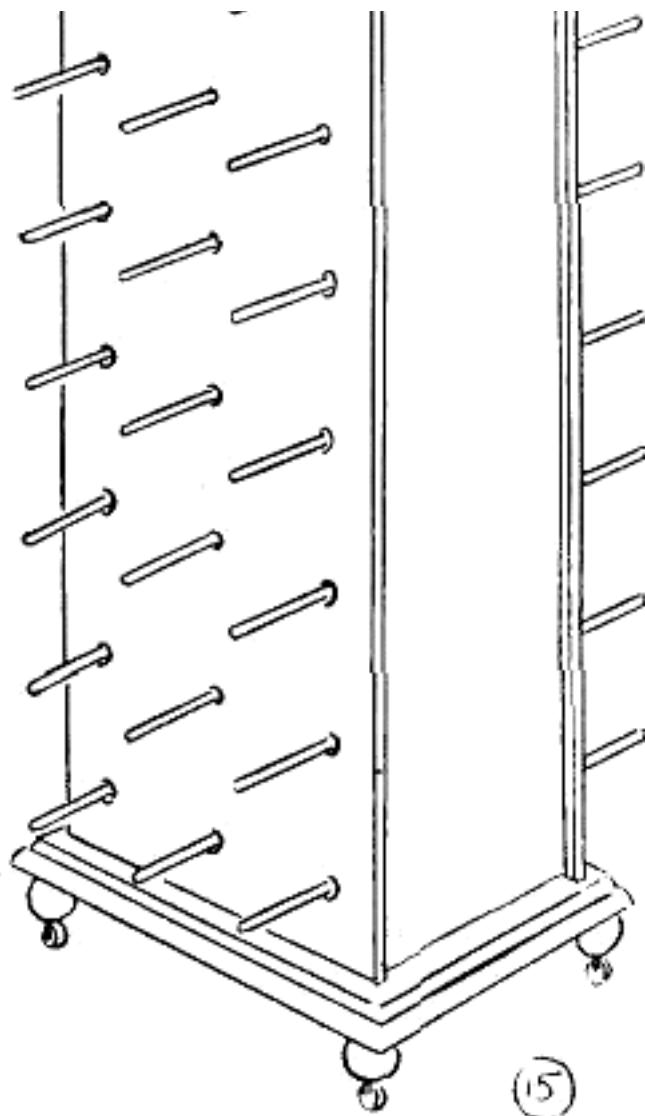
THE INDESTRUCTIBLE GIRL

EFFECT:

This is a somewhat similar illusion to the one just described. A girl assistant is placed in cabinet, apparently occupying the greater part of same. The door is closed and metal or wooden bars run through the cabinet from front to back and back to front, apparently piercing the girl. When the bars have been placed in cabinet, a small door near top of cabinet is opened showing the girl assistant still standing there. The door is closed again and bars removed. The door is opened and girl steps forth uninjured. Or bars can be left in

(56-8)





(15)

cabinet and lid opened, a trapeze let down from above to which girl hangs by hands and is pulled out of the cabinet. This is the desirable finish if playing where a pull-up can be worked with above stage arrangement.

PARAPHERNALIA:

1 -- The cabinet.

2 -- The metal or wooden bars which should be long enough to extend about six inches on each side of cabinet.

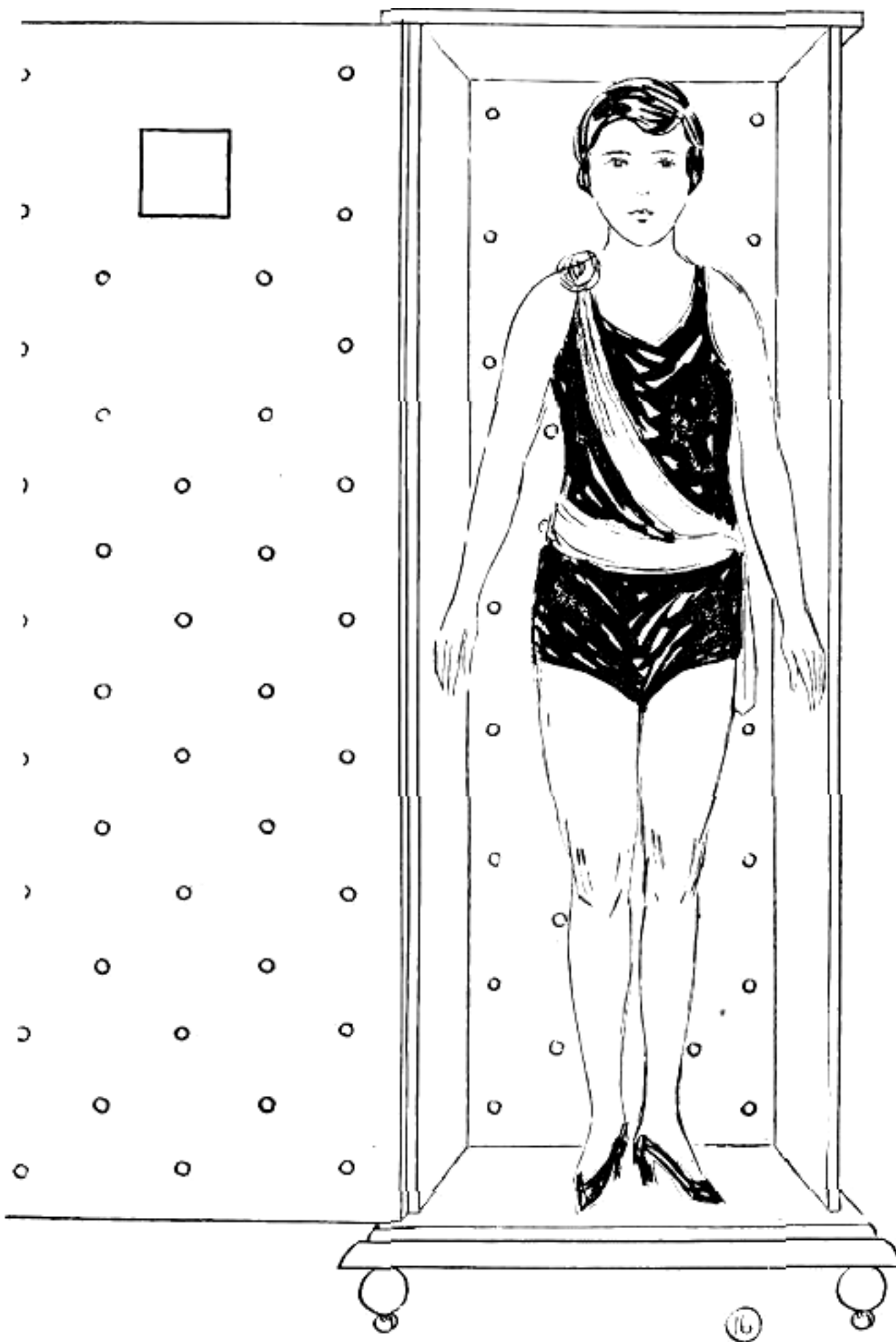
3 -- A trapeze.

PREPARATION:

THE CABINET:

This is built similarly to one in the penetrative bar illusion described before except that it is not necessary for front and back to overlap box proper, the holes can be varied and made more numerous and closer together. It is however necessary to make the box deeper, as more room is required so as to double up the body from another angle. Inside measurements are about 24 inches by 24 inches by 5 feet 9 inches. A cabinet for small girl can be smaller in height. The holes are about 8 inches apart up and down. A small door must also be placed in front door near top to be opened so as to show

assistant's face inside at any moment. The door need only be about five or six inches wide and six inches long. Just so face can be seen.



The small door also has another purpose. It takes the place of holes for bars and allows considerable space in upper region of cabinet in which no bars are thrust and it is in this space that the girl assistant can secrete herself to a large extent and thereby avoid the thrusts of the bars. Fig. 16 gives a good idea of box.

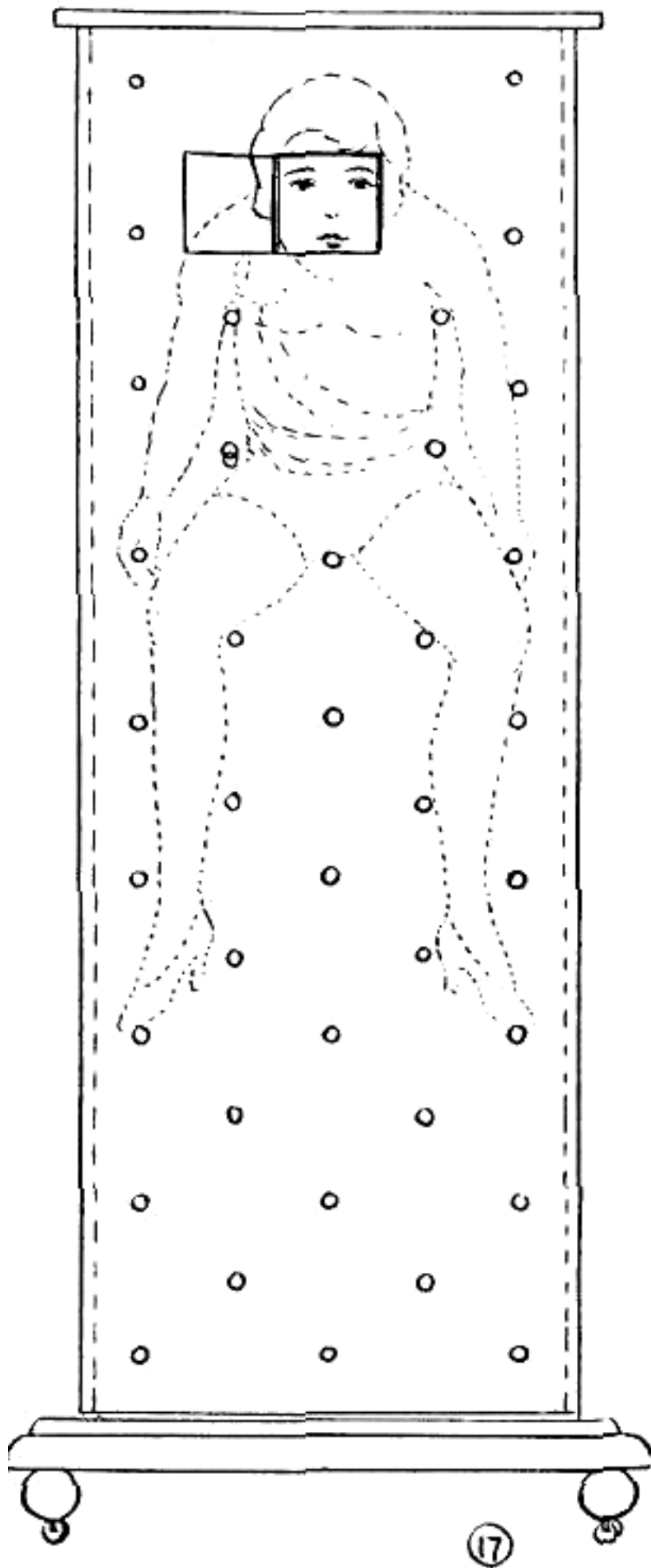
THE TRAPEZE:

If the pull out finish is desired, this will require a trapeze arrangement which must be suspended by pulleys from above and leverages so that she can be easily pulled up from floor below. In the theatre facilities are especially arranged for these lifts.

TO PERFORM:

Cabinet is
brought
forward and
girl
assistant
steps in it
backwards
and faces
audience.
Fig. 16.

(56-10)



The door is closed and fastened. The little door is opened and girl shown looking through it. The door is closed again. The bars are placed through the holes in cabinet in a routined order that must be learned by all performing the penetrative part of illusion. Bars must be placed in from above and below so that girl will have something to step up on like a ladder and can hold on to something in making her upward ascent. When she once gets up out of danger, balance of bars can be thrust through the cabinet. It will be necessary for her to help direct bars to exit holes many times.

When bars are all in cabinet, the small upper door is opened, a signal first being given so girl can adjust her face in front of it. To audience she seems to be in the same position that she was when first placed in the cabinet. Fig. 17.

The door is closed and fastened and the trapeze is lowered from above while you raise lid of box. Trapeze comes low enough so that girl can raise up hands and grasp same. Trapeze is pulled up, Fig. 18, and girl comes up out of box and is let down onto the floor.

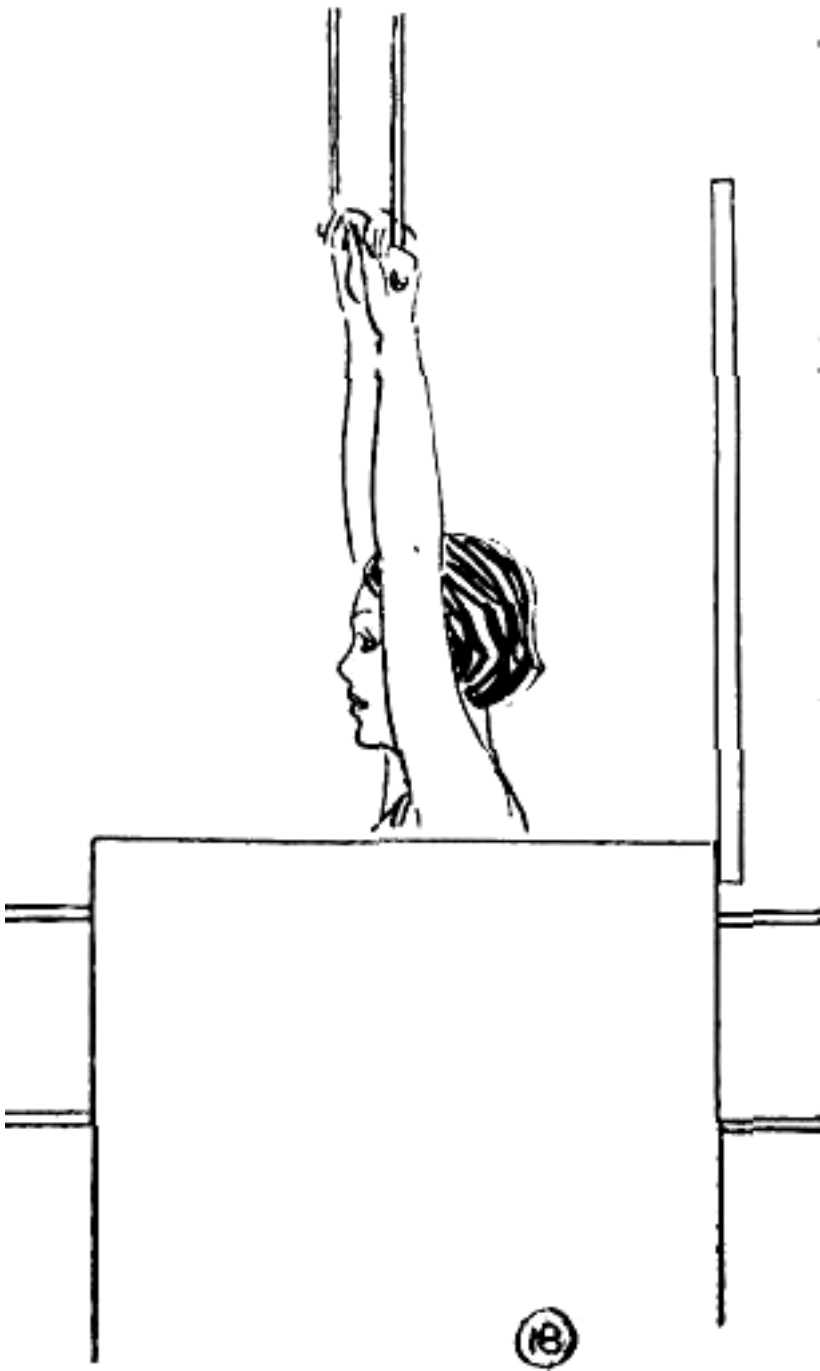
Or you can finish by removing the bars quickly and opening door again, showing the girl who steps out, bows and takes the applause.

NOTE:

In this method of working bars could also be thrust through box through the other two sides. It is really remarkable what you can do with an illusion of this type by using ingenuity. Try it—you'll be surprised!

At one time this was one of the most
'sensational illusions

(56-11)



on the stage. The effect of sawing a woman in half was a good box office attraction. It gave ample opportunity for good publicity. Even to having an ambulance standing out in front of the theatre with sign attached that it was ready for emergency in case of any accident that may occur in sawing the lady in half. A big steel saw such as used to fell big trees was hung in the lobby.

Selbit of England had a method of performing as did Horace Goldin. Much discussion came about as to whether Selbit or Goldin was entitled to credit for the illusion. Then the movies took it up and started an expose which reached a certain number of people.

I cannot give accurate information as to who invented the illusion. Both Selbit and Goldin performed it admirably. The effect of each varied though as in Selbit's method the girl was tied inside a package case while in Goldin's version the girl's head and feet were visible, being held by assistants from the audience.

Charles DeVere, well known magical dealer of Paris, France, showed me a catalog advertising sawing a woman in half before sawing a woman became popular. If I remember rightly, it was presented by some magician in the year 1843. But what his version was I do not know. The old wood cut showed a box supported on sawbucks. Anyway, it never received much popularity and publicity until Selbit and Goldin got hold of it.

Horace Goldin made a vaudeville tour throughout America with the illusion some time ago, and his presentation and showmanship were those of a master.

Servais LeRoy some time later made a vaudeville tour with the "Sawing a Woman in Half" illusion and presented it as a hospital scene in which audience were watching a surgical operation.

Harry Jansen (Dante) and Thurston added some good wrinkles to the Goldin version and it became a good attraction with their shows. Even as I write this they are both having fine success with it.

Millions of people have not seen the illusion and new audiences are arising so it will be popular for many years.

In this lesson I am giving you a version based on the Selbit version. It is not as elaborate, but it is very effective and can be built very reasonably.

In giving you illusions I am trying to keep down the expense as much as possible. I could explain some illusions that would cost hundreds of dollars to build, but they would not be practical to the majority of my students. They might interest curiosity seekers, but, as I have said before, "This course is not built for curiosity seekers, but for those who want to learn to present practical magic and get some place with it."

The effects in this course are selected because of their power to be tied up with SHOWMANSHIP and for their production with as small an expense as possible. Yet the effects can be elaborated upon and permit of thousands of dollars being spent on and around them as the conditions satisfactorily warrant.

IT REQUIRES YEARS OF EXPERIENCE TO KNOW VALUE.

And what may seem like a strange statement, only a minority have learned it in the magical profession. And their success has been measured accordingly.

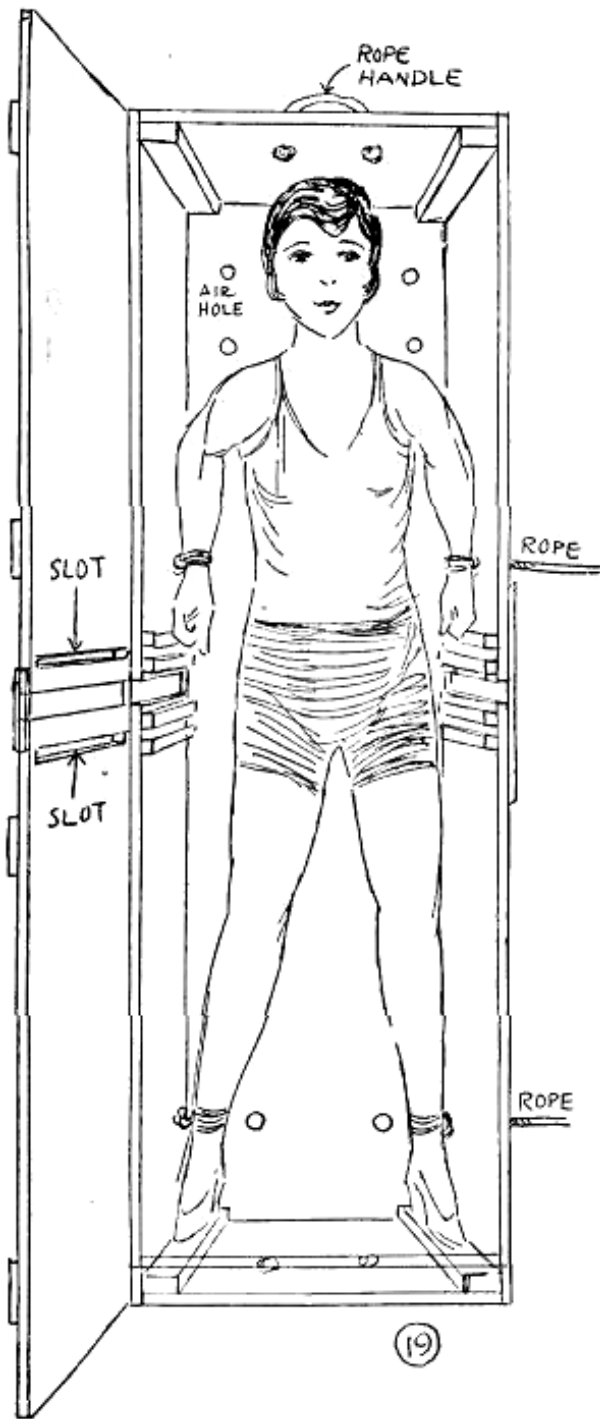
But let us take up these things later on and now talk about sawing a woman in half without hurting the lady.

EFFECT:

A box similar to a packing case is shown, into which a girl is placed after having tied pieces of clothesline firmly around her wrists and ankles. The clothesline in turn is threaded through holes in the box, and to be sure that girl does not pull in the rope a piece of wood is tied in rope close to each opening. Four members from audience are each given an end of the clothesline to hold. Thus the girl is shown securely bound in the box. Her ankles are securely bound near the bottom of the box and her hands towards the upper part. The door is now closed and fastened with padlocks. The box is now picked up and placed on sawbucks or on two frames similar to table, having a castor under each leg so as to move about easily. Performer brings forward a large saw such as is used by two people to saw lumber and trees. Performer takes hold of one end and gives a spectator the other. Together they slowly saw the packing case in half, all the way until the saw comes out at the bottom. Apparently the girl who has been tied up inside and held in place by gentlemen holding the ropes has been sawed in half. To still prove what has been done, the performer places two slides, one on each side of center cut where slots in top of case have already been made for the occasion. The two halves of the box are then separated for three or more feet and the performer walks in between them. The two halves are brought together again and the slides removed. Performer commands girl to restore herself. He then pulls the boxes apart a couple of inches and shows her body lying across the opening. He then cut the ropes loose from the outside of box, thus freeing the girl's wrists and ankles. The locks are unlocked, the lid opened and girl stands up. The halves of boxes are separated and girl steps down unharmed by the sawing process.

PARAPHERNALIA:

- 1 -- The box and two slides.
- 2 -- Two table-like frames upon which to place box.
- 3 -- Clothesline. A fifty-foot hank of soft white clothes-line.
- 4 -- Four wooden pegs about six inches long and a half-inch



in diameter.

5 -- A cross cut saw with handle on each end such as is used for two people in cutting large timberwood.

PREPARATION:

THE BOX:

Here again illustrations are of much value in letting you quickly size up the situation in the construction of the box. The inside length of box should be about three to six inches taller than the girl. The other measurements should be about 21 x 21 inches (inside).

Fig. 19 shows the box with girl inside.

Ropes are fixed in ends of box for handles. Where necessary, cleats can be put on box to strengthen. The box has a lid which hinges on one side. On the other side it is fastened with two hasps and padlocks.

The box is then sawed in half and then held together with soft pine boards about a quarter inch thick through which the saw will easily penetrate. You will note an opening of an inch or two between the two halves of box proper but covered with the strips, sides, top and bottom.

A slot is cut on each side of the center through which a metal or wooden slide can be inserted at proper time.

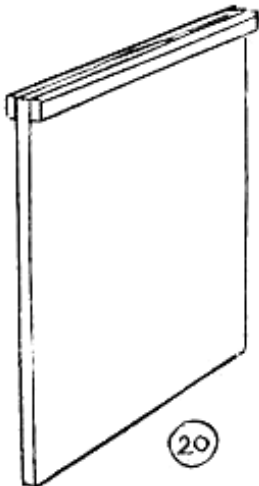


Fig. 20 shows a picture of the slide. To cover slots, wooden doors are hinged. Directly below the slots are grooves to slide the slides into and be held firmly. Thus the halves of boxes when sawed could be pulled apart without anyone seeing on the inside of boxes.

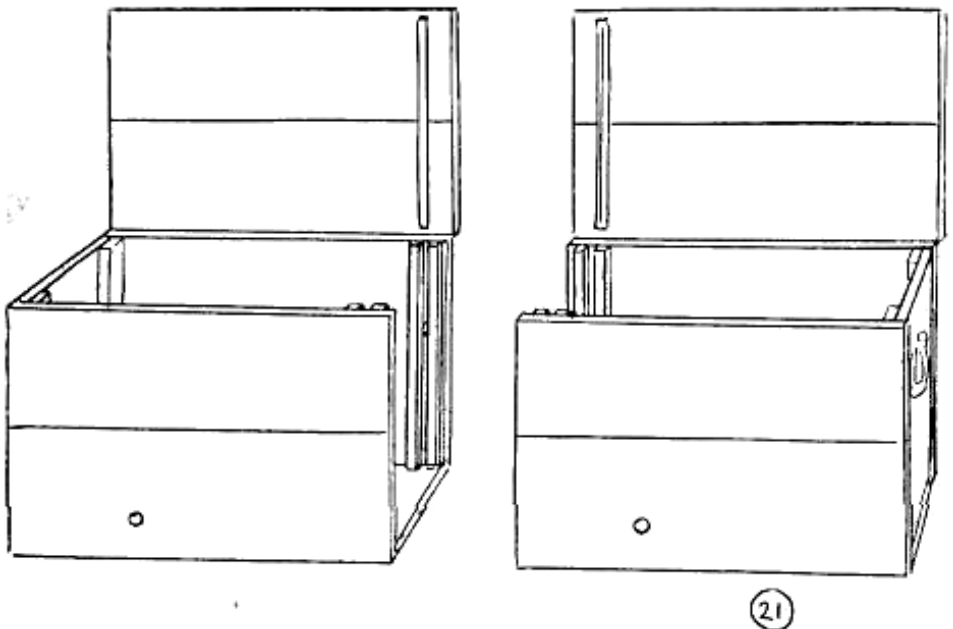
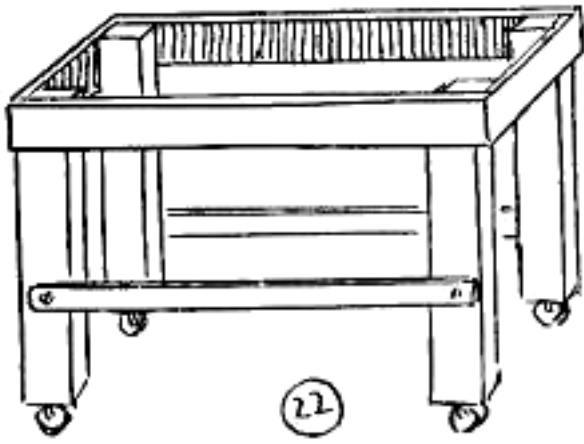


Fig. 21 gives another view of the halves of boxes before they are joined together with the strips of pine wood.

In the bottom of box are a number of air holes. On the sides of box are holes through which ropes can be carried outside to spectators after girl is bound in box. Figs. 19 to 21 show the location of these holes.



THE TABLE FRAMES:

You will need two of these to support the box so at proper moment when box is sawed you can pull frames apart, each bearing a half of the box.

Fig. 22 shows the frame. Each leg has a castor on bottom. In emergency four saw horses can be used.

PUBLICITY

If you do not care to carry a saw with you, it might be possible to have a local hardware store cooperate with you to use one of their saws and then credit them accordingly. You can say in your publicity that saw is furnished by so-and-so.

You could even submit blueprints or sketches to a department or hardware store and have them build box and frames, supply the rope and saw for the publicity that you would give them. Perhaps you could have them exhibit the box and saw in their window with a card announcing that on such and such a date, at such and such a place, you were going to saw a lady in half and this store would furnish the material to do it with.

This plan of publicity is suitable for any city or town, large or small, that is large enough to support your show. But always try to pick out the most prominent dealer.

TO PERFORM:

Have the box in the center of stage.

The table frames are at side of stage in readiness. On a chair or in care of assistant are four twelve-foot lengths of clothesline and the four wooden pegs.

The assistant has a sharp safety razor blade of the Gem or Ever-Ready type in his vest, upper trousers or coat pocket that he can get at handily and yet not cut himself doing so.

The girl assistant has a similar blade concealed in the upper part of her trunks. A special picket can be made for this blade so as to carry it and get at it safely. The pocket might be leather-lined, or at least of very substantial material.

It might also be well for girl to carry a very small flashlight concealed on her person.

By having air holes in bottom of box and properly lighted

stage, she might get enough light to see what she is doing inside box, or even by feeling. But a flashlight might be handy for some assistants if properly used. But care must be taken that light does not show through holes through which ropes go. Just a flash here and there may help in freeing herself from the ropes.

You come forward.

"Ladies and gentlemen, I take pleasure in presenting to you one of the really ingenious mysteries of magic somewhat in the nature of a surgical operation and one which has baffled doctors, scientists and students of biology, physiology and anatomy time and time again. The experiment is so unusual that you will remember it for many years to come.

"In order that you might see the experiment properly presented, I am going to ask a number of serious-minded people to come upon the stage, such as doctors, lawyers, teachers, business men.

"This is a serious experiment and I must have serious-minded people. I would rather at this time have no children, but rather older people who will stand ready to help me, particularly should any emergency occur. I would appreciate it if a physician and surgeon would aid me. Will eight or nine good people come up to assist me?"

Have spectators who volunteer to assist you come up on stage and have plenty of chairs so each can be seated, say four or five on each side of the stage. Do not have children come up. Should any come forward, you can have them sit down again, with a bit of diplomacy.

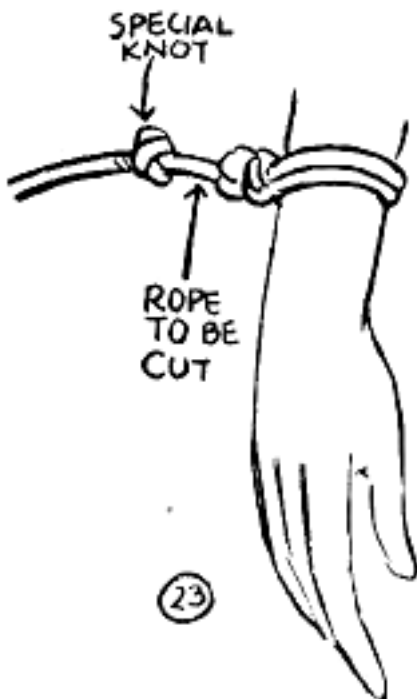
PATTER:

"As I have already said, you are about to witness a most unusual experiment. No matter what happens, keep your seats, keep as calm as possible and do not become hysterical. Should an emergency occur, just let me handle the emergency and direct those who are on the platform here to help me overcome it. I say this, because one may never know what a hysterical person may do nor his or her effect on an audience. So, no matter what happens, keep calm and leave the outcome to me. Magic is prepared with emergencies unknown to most people.

"I am pleased to introduce the young lady who will assist me."

Girl assistant comes forward from off stage and stands beside you.

"Miss" Call her by name.



"First I want to bind her wrists and ankles, and will ask two of you gentlemen to assist me."

Have two gentlemen help you, first binding the wrists and then the ankles. You can bind one wrist and show gentlemen how to do other wrist and ankles. You bind with one end of rope, leaving other end free.

When the tying is done, man assistant stands at girl's left and you at her right. You pick up rope attached to wrist and tie a single knot with other end so that single knot will pull up and tighten within about a half inch or so of the knots on wrist. Fig. 23. The reason for this is to allow a bit of rope to be cut with razor blade later on. Assistant does the same at same time with other wrist. Then you each fix ankle the same way. Audience thinks you are just making things extra secure.

PATTER:

"There, I think she is securely bound."

Turn to the box.

PATTER:

"Gentlemen, this box was built by for this experiment. (If you are having local dealer build it.) Would you be kind enough to examine it, if you choose."

Have girl step into box, back foremost and stand as in Fig. 19.

PATTER:

"The ends of the rope will be run through a corresponding hole to accommodate it."

Assistant steps in box and runs ropes through proper holes while you pull them through from outside until girl's wrists and ankles are pulled tight against the box.

The right wrist is fastened last and, under cover of his back, assistant cuts the rope between extra knot and other with razor blade, and conceals blade again. This is but the work of a moment. You can vary this by changing places with man assistant and cutting rope yourself. Girl holds her wrist against extra knot and box in such a way that she is still apparently tied securely. Have a gentleman or two examine the ropes going through the box to see that everything is fair and square. This examination is superficial. You merely touch right wrist and rope, then show left wrist a little, and finally ankles.

"I am going to ask gentlemen to each hold an end of one of the ropes, but before doing so, to keep her from pulling in any rope and make her doubly secure, I will just tie a wooden peg to the outside."

Have gentleman watch you closely, and even he can tie one or two. Tie knot as near an inch or so from box as possible.

"I think you will agree with me that my assistant is firmly held secure in the box, her ankles at the bottom and her hands much farther up. To further convince you, I want you, sir, to hold an end of this rope tightly."

Give end of rope to a gentleman to hold. In like manner give each rope to three other gentlemen to hold. Assistant brings the two table frames to rear of box and puts them in place.

You close the door of box and lock it with the two hasps and padlocks. Assistant takes rope handle at one end of box and you the other, and you lift the box with girl in it over onto the frames. If necessary, you can have one or two of the gentlemen help you.

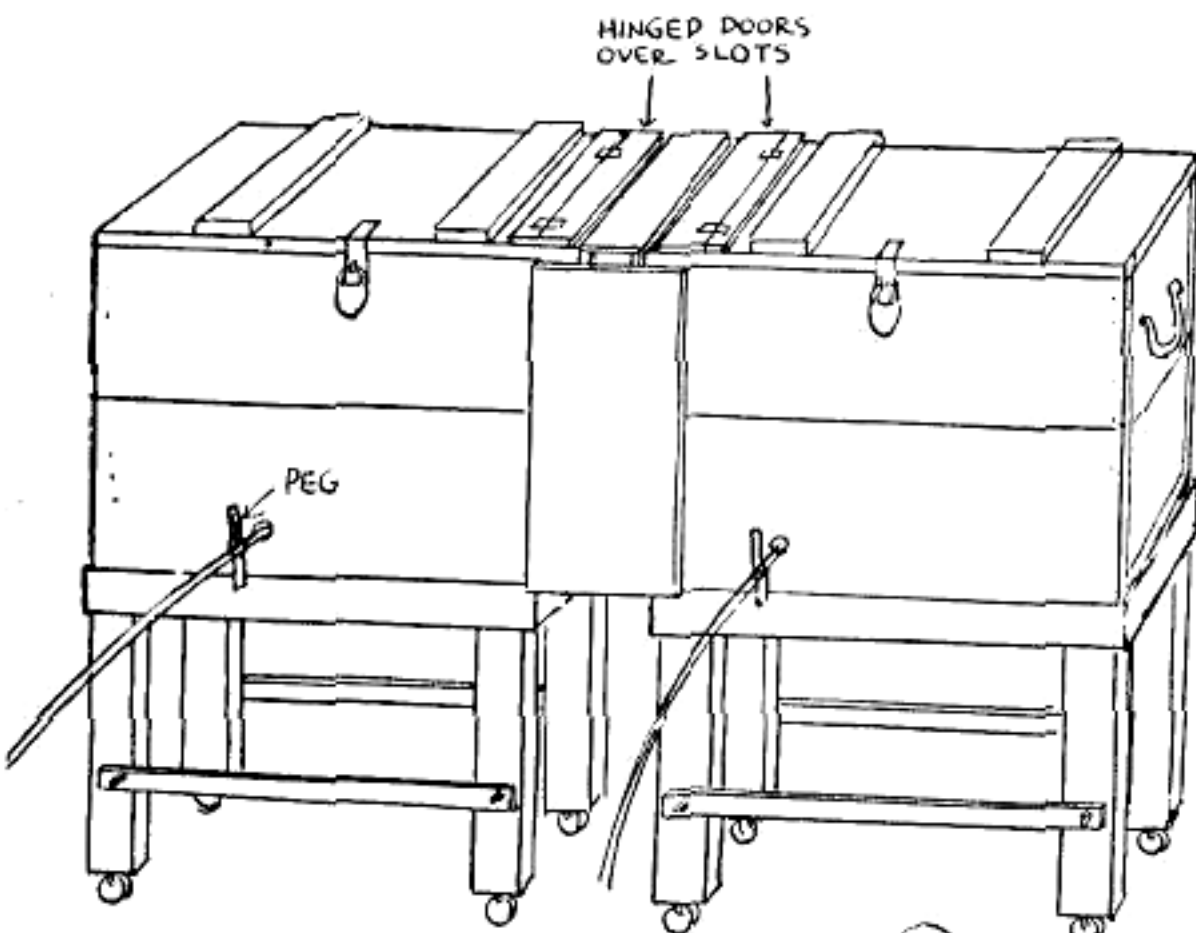


Fig. 24 shows the box on the table frames. Padlocks face audience.

The gentlemen holding the ends of rope are each seated in a comfortable position so they can hold ropes tense and yet not screen box or operations from audience.

"Now you gentlemen holding the ropes, I am going to depend on each of you to hold tight and keep her wrists and ankles firm against the sides of the box. I had safety pegs put

in for extra
care, but I want
you yourself to
pull tight. If
she moves ever so
slightly, you can
feel it."

NOTE:

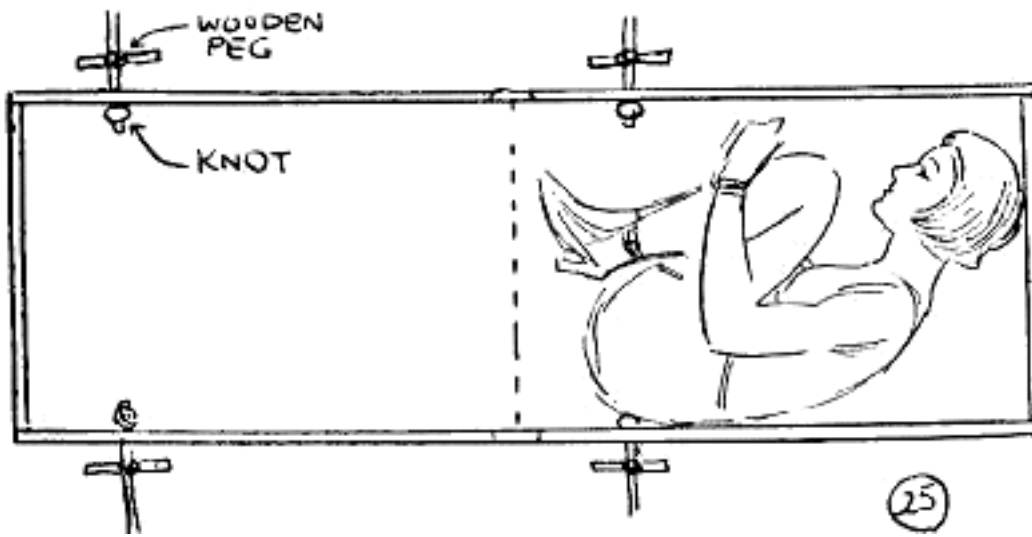
The moment box is adjusted on frames, the girl inside takes the razor blade she had concealed and cuts the rope between extra knot and other knots of left wrist with her free right hand.

THE IDEA OF THE EXTRA KNOTS IS TO PREVENT ROPES FROM BEING PULLED FROM BOX. This illusion depends on making spectators holding ropes think they still have girl tight against box when in reality they only have the extra knots against the box.

The holes in the box are only large enough to freely let the rope pass through, and will not admit a knot.

The girl reaches down and cuts the ropes at ankles in similar fashion, thus freeing herself. She places blade back in secret pocket.

(56-18)



When sawing commences, she has now but to pull herself up into upper part of box as in Fig. 25. This illustration shows a cross section of the box looking from above downward.

Note position of ropes and knots.

With the girl curled up in this position, the saw misses her entirely when it saws box in two at the center. There should be no loose skirts to catch or be in the way. Should skirts ever be used, be sure they are pulled up around body at this stage.

GIRL SHOULD USE EXTREME CARE TO SEE THAT SHE IS WELL OUT OF THE WAY OF THE SAW. There is no danger of being hurt if care is used.

Assistant brings in the saw and gives it to you. He should also give you a hammer. You hold saw up by one end with other one on the floor. Strike the metal at center with the hammer so as to give loud ring. By manipulating saw you can change tone into a moaning one.

Throw hammer on floor and allow saw to fall on floor with with a bang.

This is a bit of showmanship to show strength and metallic nature of a real saw. There is no doubt but what it IS a saw.

"Now, is one of you gentlemen a surgeon?"

If there is one, have him stand up.

"I am mighty glad you are here. I trust you dp not mind helping me perform a slight operation on the young lady."

Pick up the saw.

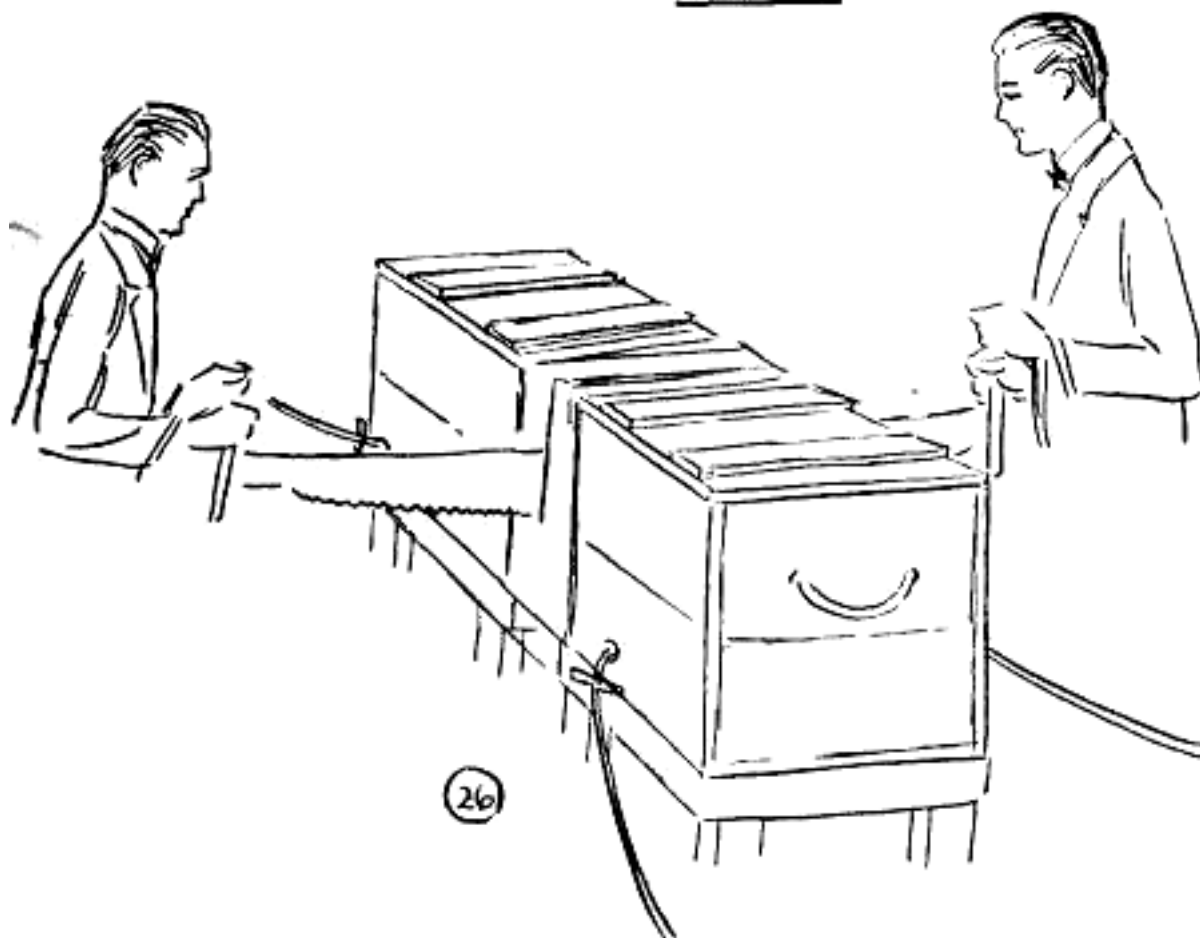
"I do not know, Doctor, whether you use a saw this large in your practice or not, but I use one this large as it is necessary to operate on the box as well as the

patient."

Go to rear of box with
saw, and place saw across
the center.

(56-19)

"Doctor, I will ask you to take hold of the other end of the saw and help me saw down through the box. Now when we get down to the girl. I do not have to warn you to be just a bit careful."



You start the sawing. Each stroke should be slow and steady. Occasionally stop a moment and look over box to see that all is well apparently. Fig. 26.

Every time you pull the saw across the box and cut deeper, the TENSION INCREASES in the audience. This is a high spot in the illusion and you want to give the audience an emotional thrill.

When you come down to about where the girl would be, you stop sawing again and, pulling handkerchief out of your pocket and wipe your forehead. Place handkerchief back in pocket.

"Now, gentlemen holding the ropes, hold tight and do not let anything slip. And, Doctor, just be careful of your end of the saw."

You now come down rather forcefully with saw.

As saw is drawn across the girl inside gives a shriek. You quickly let loose of saw a moment, but say to Doctor:

"Hold tight, Doctor, hold tight! Gentlemen, hold your ropes tight."

You look about the box and place your ear against the top

of box right over
where girl's heart
would be if she
were lying normally
in the box.

NOTE:

This is showmanship
and done to work
the audience up to
high pitch. They do
not know whether
you are going to
get through with it
successfully or
not.

If you want to
inject a bit of
comedy here to
temporarily break
the tension, have
one of the
spectators sitting
on side of stage,
but not actually
assisting, suddenly
get up when you saw
again and run down
off stage and back
to his seat, or
even to the rear of
the theatre. This
could easily be
planned by posting
a spectator what to
do at the moment
you give him
signal.

You bring the saw
down again.

"That's right,
Doctor, be
careful!"

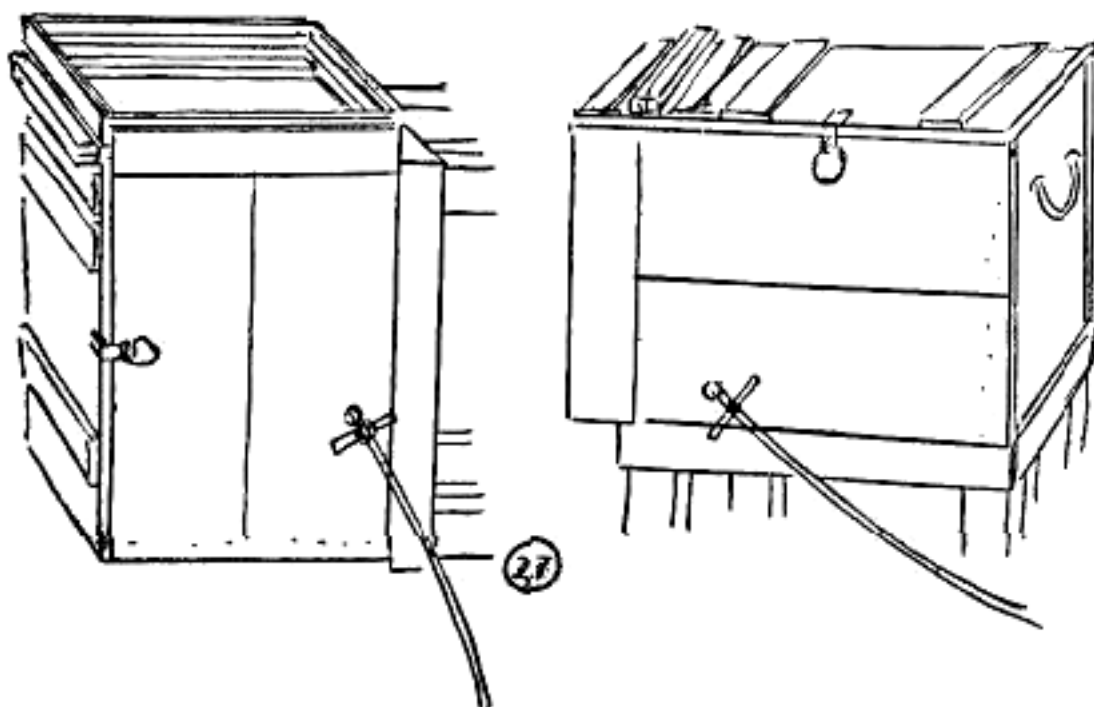
Finally by degrees
you saw the box in
two and saw comes
out below. You take
saw and lay it on
floor behind the
box.

(56-20)

Assistant hands you one of the wooden or metal slides. You lift up one of the boards covering slot in top of box and insert the slide down into same. When it comes down to place about where girl's body would be, apparently have difficulty in getting slide to go down. So turn to gentlemen holding ropes governing that half of box, saying:

PATTER:

"Give a little jerk on your rope."



They do so, and you push the slide down into place. This is effective as apparently the body was in the road of slide and the jerking of rope pulled the body back a bit out of the way.

Place the other side in place with similar performance.

Push the two halves of the boxes apart. Fig. 27.

Walk between them.

The effect of the two boxes being apart creates a peculiar effect on the audience.

Doctor, of course, has been told to sit down, and you and assistant are only ones standing. Assistant is behind and you control situation from the front.

Quietly say to audience.

PATTER:

"There she is peacefully resting in two pieces. She could stay this way for some time without injury, perhaps ten minutes, perhaps fifteen. However, the minutes go by quickly so let us bring her back to herself again."

You walk between boxes again. Then assistant helps you bring the two boxes together again. You pull out the slides and bring hinged doors over slots.

You stand in back of
boxes, a hand on each.

Say quietly, yet
distinctly:

"By the powers of magic
that be, by the laws of
the ancient mystic and
wise, I command you to
become one again. It is
done."

As you say this, girl
adjusts herself in
position again. Pull
boxes apart, say about
two inches, showing
girl's body. Bring boxes
together again.

With large scissors or
sharp knife cut the
ropes on outside of box
close to box, allowing
outside rope and wooden
pegs in knots to fall to
the floor.

(56-21)

In this way, you apparently free the girl. She in turn gets hold of the extra rope and knots inside and hides them on her person.

You then unlock the padlocks freeing the lid. You raise the lids up, and girl stands up. The ropes are still tied around her wrists and ankles just as if she had been cut loose.

You push boxes apart, showing inside to audience.

Then help girl to floor. Take bow and applause.

Dismiss the committee, shaking hands and thanking them as they leave stage.

NOTE:

To prepare for next show, it is easy to remove strips of wood at center of box and add new ones to hold the two halves together again.

A handwritten signature in cursive script that reads "Harlan Tarbell". The signature is written in black ink on a white background.

TARBELL SYSTEM, INCORPORATED, Chicago.

LESSON 57

"The Chinaman, the Ghost, and the Cat," a Chinese Fantasy. "The Mystery of the Three Ghosts." Watch for this unusually fascinating lesson.

* * * * *

The paraphernalia described in this lesson can be obtained from the Tarbell System, Incorporated.

(56-22)

THE CHINAMAN, THE GHOST AND THE CAT

A Chinese Fantasy

In this lesson we will take up the art of pantomime in illusions. There is an excellent opportunity for the modern day magician to clothe his illusions with a pantomime story. In this way what might be used for an illusion lasting for a few moments can be lengthened to an illusion story, an act or almost an act in itself. Cabinets as commonly used in illusion work are employed to vanish, to make appear or exchange one or more people. A great deal more interest and showmanship could be evolved if the vanishing or "appearing" act could be the part of a story and worked into the dramatic. There are times when a speedy production or "vanish" is essential, but there is also occasion for a story worked out in illusion form.

Who will ever forget the interesting illusion of "The Watchman, the Sailor and Monkey" as performed by Kellar? Around one illusion cabinet a whole act was built, and a mysterious one. I was yet a boy when I first saw it, but I can never forget the lasting impression that it made upon me.

With a bit of thought and ingenuity a commonplace piece of apparatus can often be turned into an unusually interesting piece of entertainment. This is where YOUR individuality comes into play - there is no limit to what you can do - no limit to the big name and success you can make for yourself.

I have often looked over stage settings back of the scenes between shows and thought, - is it possible that by putting these things into story form and combining them with living people such an interesting show can be brought forth. What a difference just a lighting effect may mean, a bit of music, and the art of the players!

There is nothing particularly interesting in an illusion cabinet itself, but the interest arises in what you are able to do with it. The same cabinet might form the basis for a hundred different stories.

"The Chinaman, the Ghost and the Cat" was originally produced by me for a Chinese stage presentation in one of the larger moving picture theatres of Chicago. The stage was set with an orchestra or band, and I had to get some sort of a Chinese fantasy blended in in front of the orchestra strong enough to become a feature number. Of course, in the up-to-date moving picture houses there is a great chance to make use of the beautiful lighting effects.

One of the most successful effects I ever worked out was to have the orchestra start a Chinese number, and while they were playing have lights gradually dimmed into the blues and the pinks, and at the same time have two cabinets eased onto the stage, revolved around and placed about twelve feet apart on the stage. Gradually the orchestra was toned down with the lights, and cabinets brought out a bit. The larger cabinet was gradually illuminated with a spot light and the illusion started. As each figure appeared, it was followed by a different colored spot light. There were bands of light thrown across the stage to illuminate the figures as they appeared on certain parts of the stage. The result was a very colorful, fantastic illusion that was an act in itself and one of the prettiest pieces of color in the stage presentation. The fantasy seemed to evolve from nowhere and disappeared accordingly. Not a word was spoken. It could have been a dream.

For another stage presentation, I would redecorate the cabinets on outside and with a different story present an entirely different stage atmosphere. Naturally the position of the cabinets would vary and an extra piece of illusion material added as needed.

With the romantic picturesqueness of the many countries, beautiful pantomime illusions could be worked up. The principle can be utilized in so many effects. Perhaps in some instances the cabinets could be built to resemble small houses, tents, etc.

Audiences are hungry for novelty and it is a wise magician who will dress up his act with novel picturesqueness. This tends to put you in the PRODUCTION class where real money lies in the show business.

Here is a chance to use your IMAGINATION and build up a pantomimic novelty on picturesque lines.

In the meantime, let us go into the details of "The Chinaman, the Ghost and the Cat" and see how the illusion is built and how the various appearances, disappearances and changes are accomplished. You will also note that only three characters are used. I will first describe the effect as seen by the audience.

EFFECT:

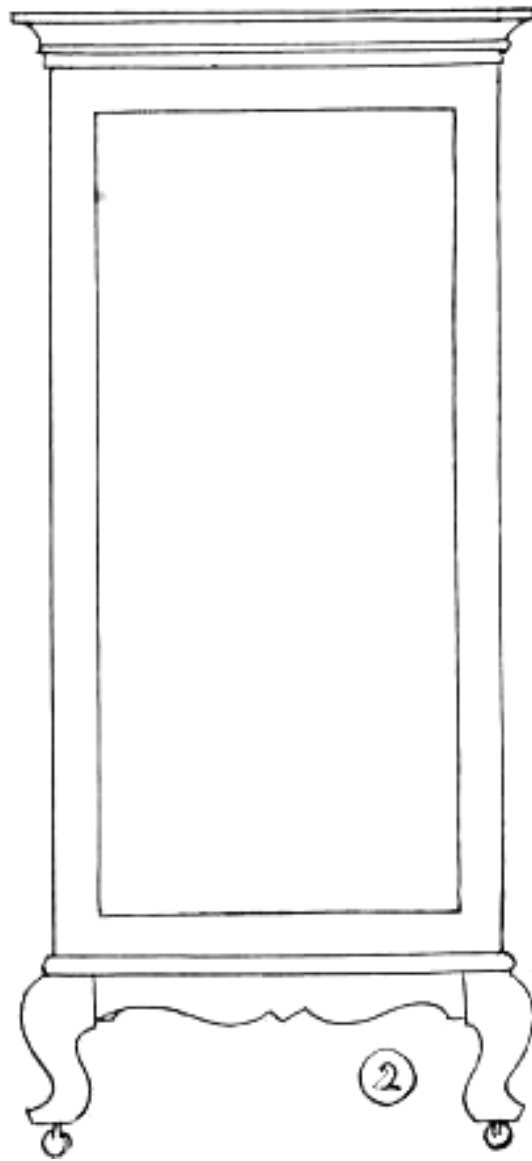
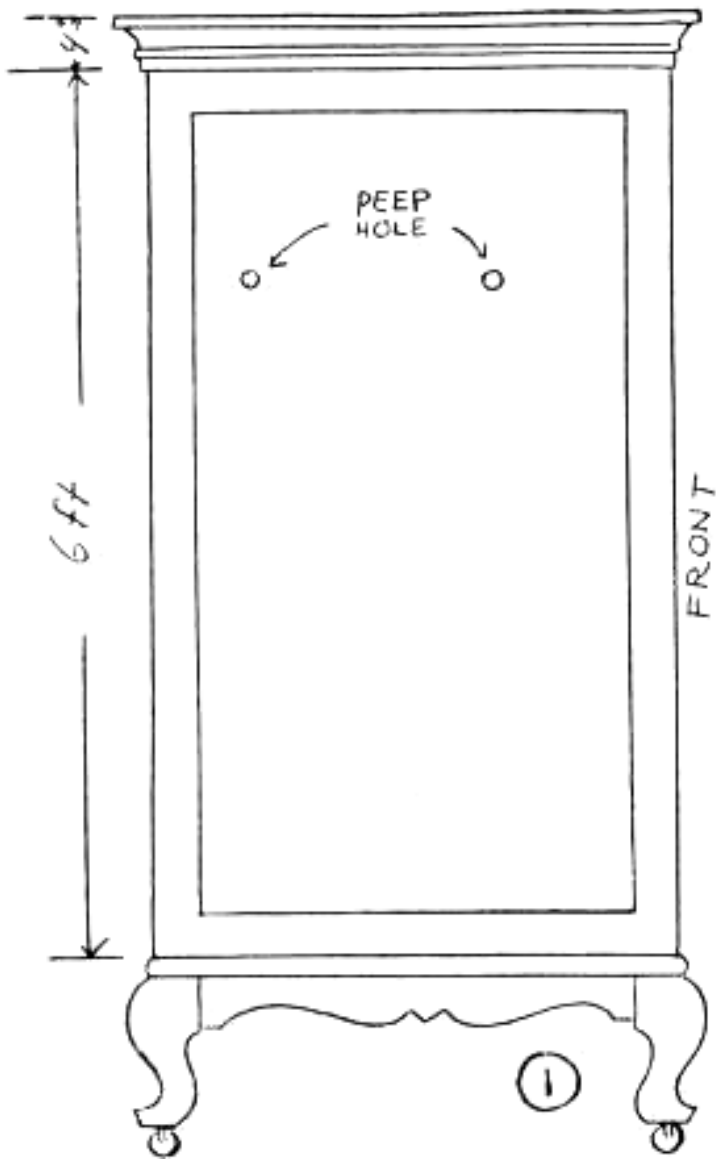
Two cabinets about ten to twelve feet apart are seen facing the audience. The smaller one at the left has a front door which is closed, while the cabinet at the right has no door, but audience can look inside. However, there is a curtain which can be closed or opened at will. The larger cabinet is empty. The performer enters, dressed in long cloak and hat with feather in it. He carries rather small treasure chest. He places this on floor. He removes from pocket of cloak a professional looking beard such as a doctor might wear, and slips it on. Then readjusts hat. Then revolves cabinet enough for audience to see rear and that nothing is concealed. He brings cabinet back to original position. He picks up chest and steps into cabinet. Suddenly the curtain starts to slowly close, screening the inside of cabinet. This is a weird effect, as no one is near to close it.

The curtain opens again and there stands a Chinaman holding a treasure chest. He gazes about, then quietly steps out of cabinet onto floor. Still looking about, he spies the smaller cabinet. He goes over and opens its front door. It is empty. He steps up into the cabinet and opens the back doors. He steps out at rear and examines cabinet carefully. He closes the rear door, then coming to front, places the treasure chest in the cabinet and closes the door.

He starts back to the larger cabinet, but notices the curtain slowly closing. He hesitates. Curtain opens again revealing a ghost-like figure in the cabinet. Chinaman slinks back to side of cabinet out of the way while ghost steps down on floor and sort of glides over to the smaller cabinet. It opens the door and sees the treasure chest. It picks it up, steps into the small cabinet and closes the door after it. Chinaman rushes over to the cabinet and opens door suddenly, only to find that ghost and chest have both disappeared. Amazed at the loss of his chest, he closes the door and starts for the larger cabinet. But again the curtain slowly closes and opens again revealing a large catlike figure in the cabinet. The cat looks around, but does not see the Chinaman. He gets down from cabinet and goes to his left and around cabinet to rear. Chinaman follows him. Cat comes on back of smaller cabinet and looks at it, then down front and turning and seeing Chinaman behind him, he rushes into the cabinet and closes curtain after him. Chinaman also rushes in after him into the cabinet.

The curtain slowly opens and neither cat nor Chinaman are within the cabinet. Curtain closes again.

Just then the door of the smaller cabinet opens, and out comes the cat with the treasure chest. He looks around, then dances around in center of stage and cuts up antics over his luck. During these antics the curtain of larger cabinet opens again and the ghost appears. It comes down to center of stage behind the cat. The cat does not see him. Suddenly ghost touches cat's shoulder with his ghostly hand. The cat gives a move of amazement and surprise. Upon seeing the ghost he makes a run for the small cabinet. He gets inside and closes the door quickly after him. Ghost goes over and opens door showing that the cat has disappeared. Over in the other cabinet the curtain is thrust aside enough to have the cat stick his head out and wave at the ghost. As ghost starts for cat, the cat disappears. Curtain opens showing cabinet empty. Ghost looks in and about cabinet. As it does this, the door of other cabinet opens and cat sneaks out and grabs chest and slips back into cabinet. Ghost finds chest has vanished, so it then comes over to smaller cabinet and, in looking for treasure chest, opens cabinet showing it empty. Ghost, shaking head, glides off the stage. The door of smaller cabinet opens and cat appears with chest and after looking about, starts for other cabinet. He places chest on floor and waves his hand at the cabinet. The curtain closes. Just then a shot is heard as performer enters from side of stage, dressed in cloak and feathered hat and beard as at the beginning. Cat sees performer and rushes into cabinet behind curtain. Curtain opens showing cabinet empty. Performer removes beard and hat and shows he is really the performer. He picks up chest and exits. Or curtain goes down as he bows.



- PARAPHERNALIA:
- 1 -- Cabinet A.
 - 2 -- Cabinet B.
 - 3 -- Costumes.
 - 4 -- Treasure Chest.
 - 5 -- Revolver with blank cartridges.

PREPARATION:

Cabinet A:

This is in reality the Protean cabinet of Servais LeRoy, and a valuable illusion cabinet, as it will hold three people self-contained, allowing cabinet to be revolved freely with front of cabinet opened.

Fig. 1 shows a side view of cabinet.

Fig. 2 shows a rear view.

Fig. 3 shows a front view with curtain pulled across the opening.

The cabinet is mounted on four legs, each having a castor.

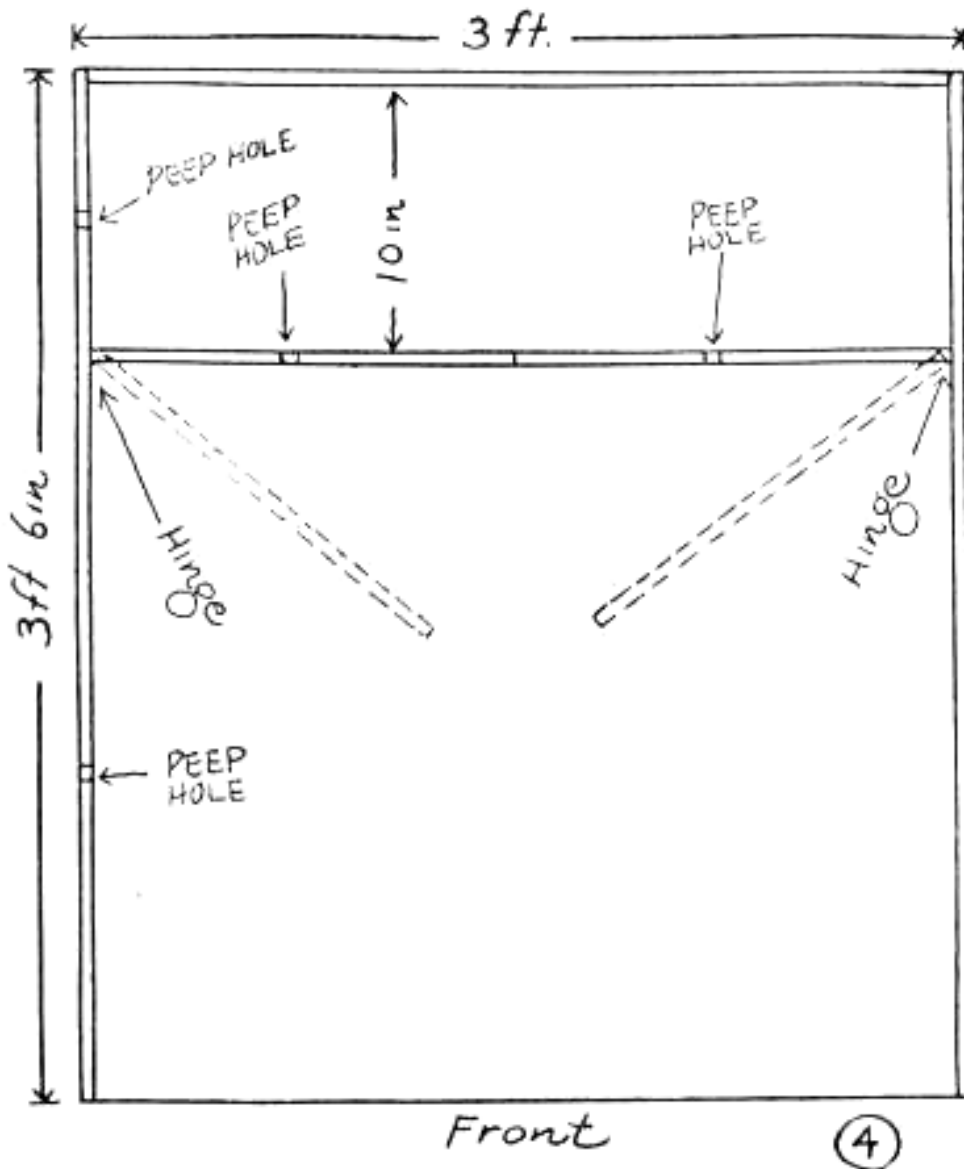
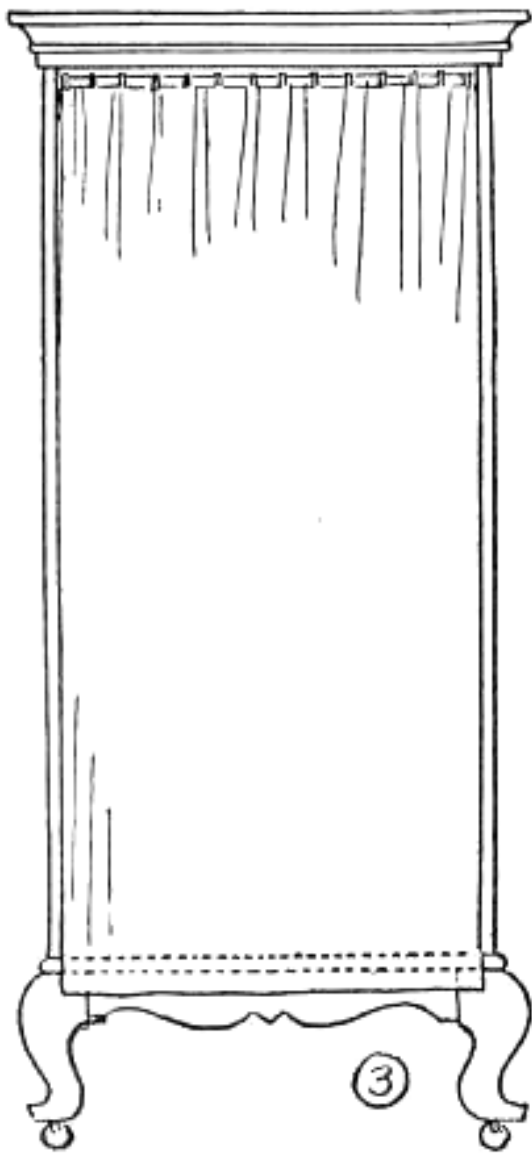


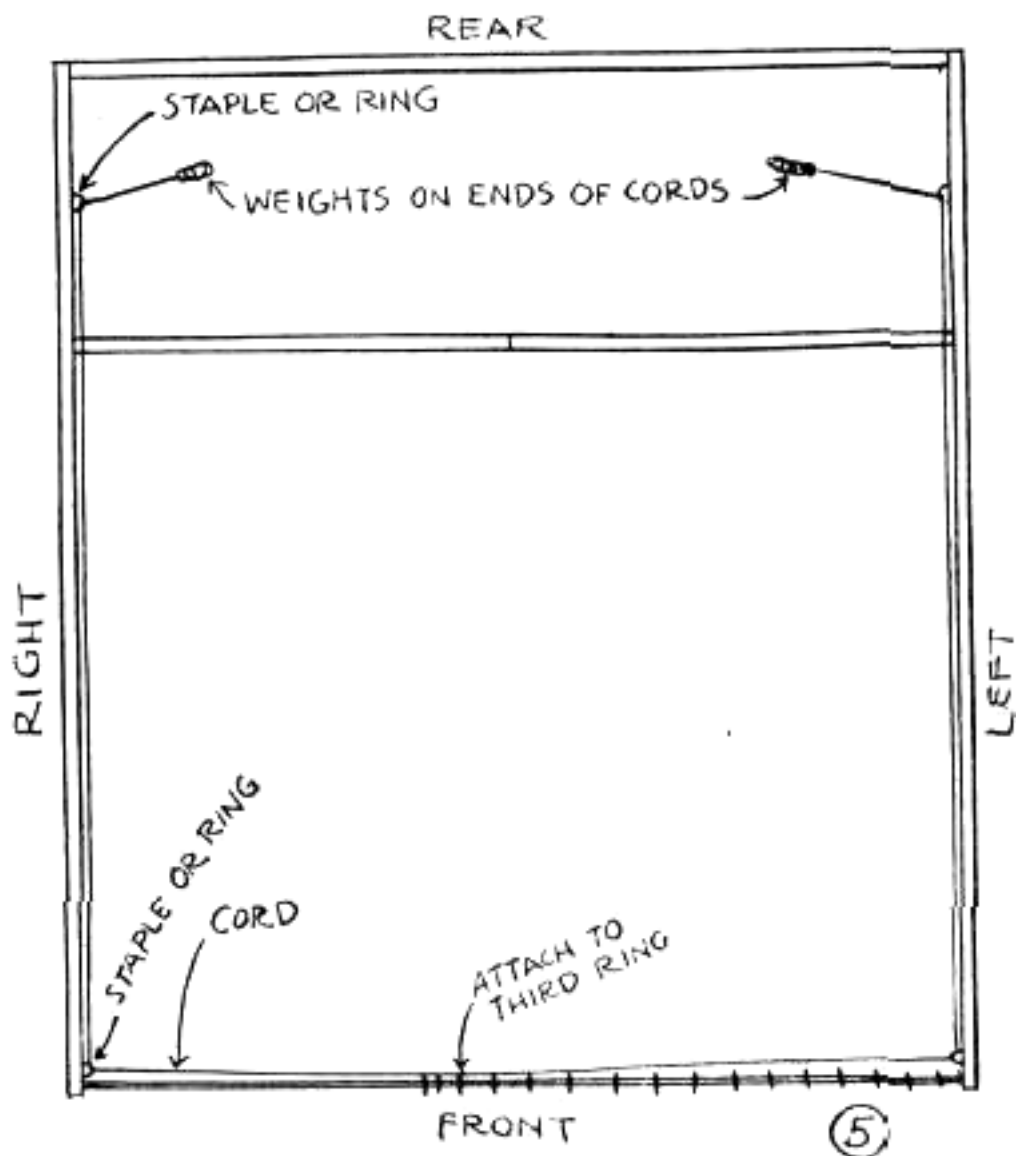
Fig. 4 shows a cross section looking from above downwards. It also gives dimensions of the cabinet. There are in reality two compartments in the cabinet, though audience sees only one. The rear compartment is about ten inches deep. The partition between the two compartments is really composed of two swinging doors. These are mounted on spring hinges or a long door spring is attached from each door to back of cabinet so that doors automatically swing back into place when opened. At top cabinet a ledge is arranged so that door will only swing back

to a specified distance. A small knob (must be invisible to audience) is attached to outside of each door so doors can be readily opened. This is a matter of convenience.

For convenience also I suggest peep holes in the cabinet, one in each door and two in wall on cabinet. This is so that parties concealed in cabinet will have a chance to look out at times to catch the action of a pantomime. The peep holes do not have to be very large, yet plenty large to get proper vision.

(57-4)

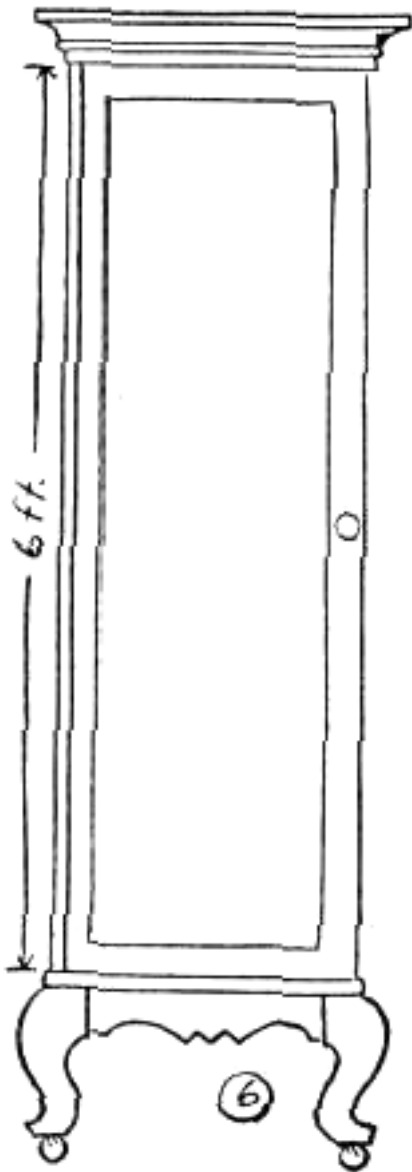
The front curtain is supported on rings and the rings in turn threaded on a metal bar which runs across front of cabinet near top. As the curtain silently opens and closes, apparently by itself, a special system must be employed. Fig. 5 shows the details. A fish cord is run from the compartment in rear from the right side (directions figured as assistant stands in cabinet facing front of stage) up through a staple near top of cabinet through a hole in door to and through a staple up in front corner of front compartment and then over to the third ring of curtain where it is securely attached. It is attached to third ring instead of first so as to allow slack in curtain so it will fully close. Then cord goes to and through staple on other side of cabinet in front corner, then through a



hole in left door and through a staple on left side of inner compartment. Each end of cord in inner compartment hangs down a bit and to each end a few washers, to form a weight, are used. Washers should be padded with cloth to prevent a noise when accidentally striking against wall of cabinet. Experimenting will show length of cord to be used. The end on right side when pulled closes curtain, while the end on left side, when pulled, opens the curtain. As curtain is controlled from inner compartment, the control is not observed by audience and therefore from the front curtain seems to mysteriously open and close of its own accord as though controlled by peculiar forces.

The inside of the cabinet is lined with a figured cretonne. Preferably one that also has a stripe in it which runs up and down. Figured cretonne, while keeping cabinet light inside, also helps to confuse the eye in depth. A person looking into cabinet sees the two doors separating the compartments, but he thinks he sees the rear of the cabinet. The outside can be decorated in good taste.

Three people can be hidden in the concealed compartment. Cabinet is made to break down for packing by using bolts and wing nuts or pin hinges.



Cabinet B:

This is a similar cabinet to Cabinet A, but smaller and with the addition that it has a back door which can be opened and the audience can look through the cabinet. Yet in a moment cabinet can be changed to a type of cabinet as Cabinet A for concealing a person in a rear compartment. I have puzzled some pretty good magical minds with this cabinet. The small size of cabinet and the opening of the rear door and looking through cabinet threw them off the track and when I would revolve cabinet with front door open they wondered just where assistant was.

Fig. 6 shows a front view of cabinet. Rear view is the same.

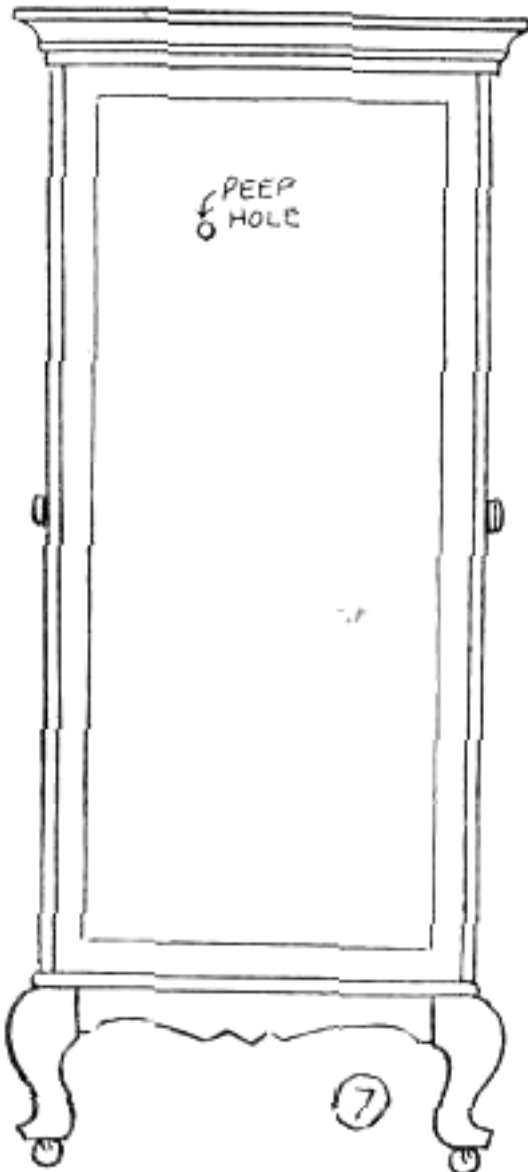
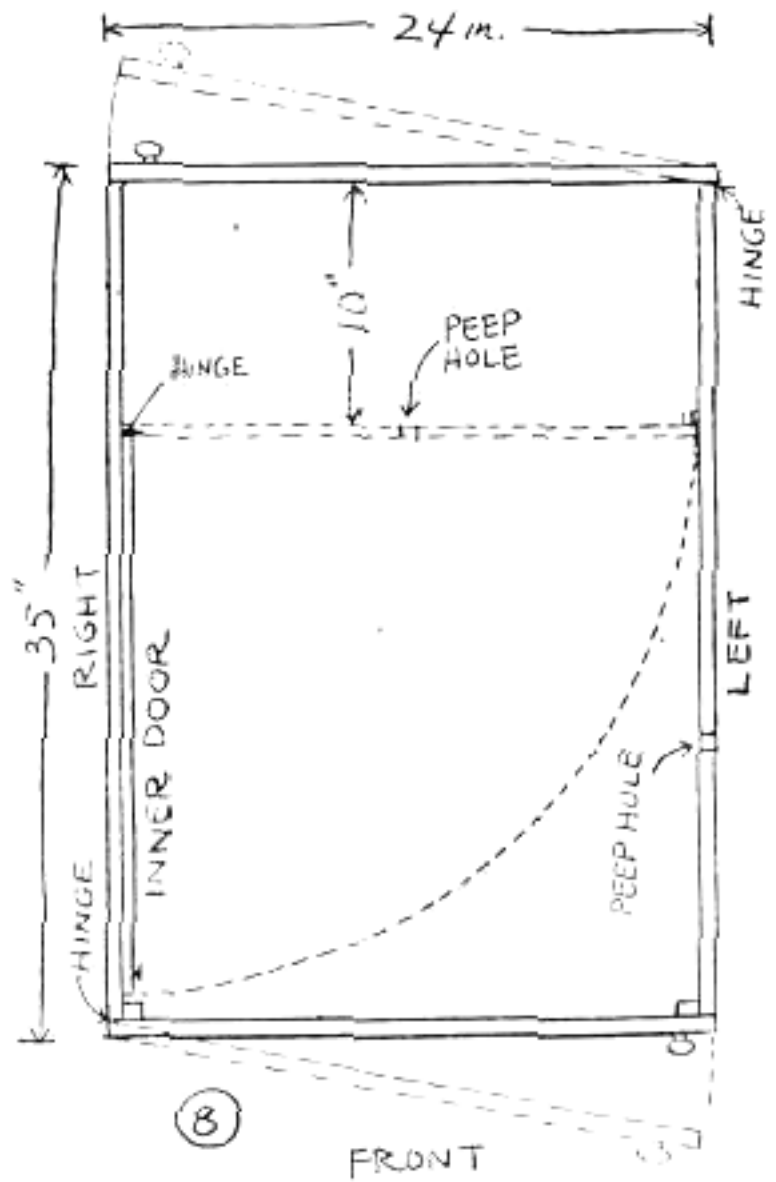


Fig. 7 shows a side view.

Fig. 8 gives a cross section.

The cabinet is 24 inches wide and about 35 inches deep. On the right side of cabinet (directions figured by assistant being in cabinet and facing front) is a door which is hinged at its rear edge and which swings across cabinet, thus making two compartments in the cabinet. The whole inside of cabinet, as well as both sides of inner door, is lined with figured cretonne, preferably with stripes running up and down and plenty of flowered figures. The idea is to confuse the eye so that when front door is opened and audience looks



into cabinet it cannot tell whether it sees the rear door or the inner door about ten inches in front of it. In this way a person can step into cabinet after having shown cabinet empty first by opening front and rear door and closing them again, and then pulling inner door in front of him. When magician opens cabinet, audience thinks they see rear of cabinet when in reality it is the inner door and thinks assistant has vanished from cabinet.

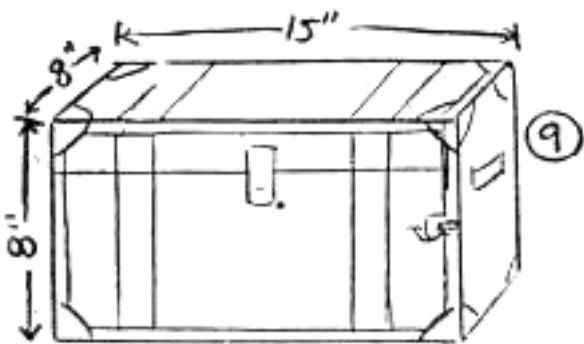
(57-6)

There is a small ledge of wood on side of cabinet to prevent inner door from swinging back too far. On inner door is a small latch, hook or piece of cord to enable assistant to easily pull door from side of cabinet and in front of him.

There should also be a catch on rear door to hold it tightly closed. A hook of some sort on outside will answer the purpose.

Front door should also have a catch so that it will not open prematurely. A spring wedge would answer the purpose, something to bind door a bit.

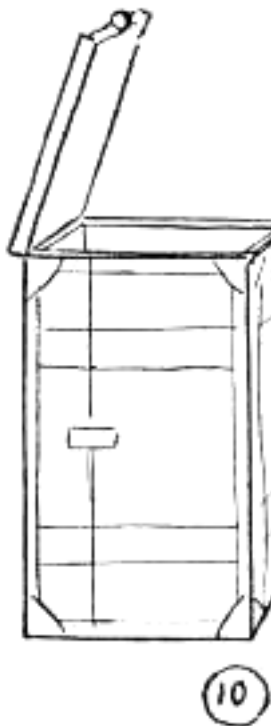
The outside of the cabinet is decorated similar to Cabinet A. Cabinet is made to break down for packing by using bolts and wing nuts or pin hinges.



THE TREASURE CHEST:

This is merely a wooden box about 8 x 8 x 15 inches. Figs. 9 and 10. On one end of box is hinged lid held in place with a hook and eye or catch of some kind to hold lid shut.

The box is painted up like a treasure chest. The opening is at one end for convenience. The idea of the box is to conceal a ghost uniform in at the proper time and must be of such size that a ghost helmet, coat and boots can be slipped into same. There can be a handle on each end for convenience in handling. Handles can be of leather or just metal rings stapled on.



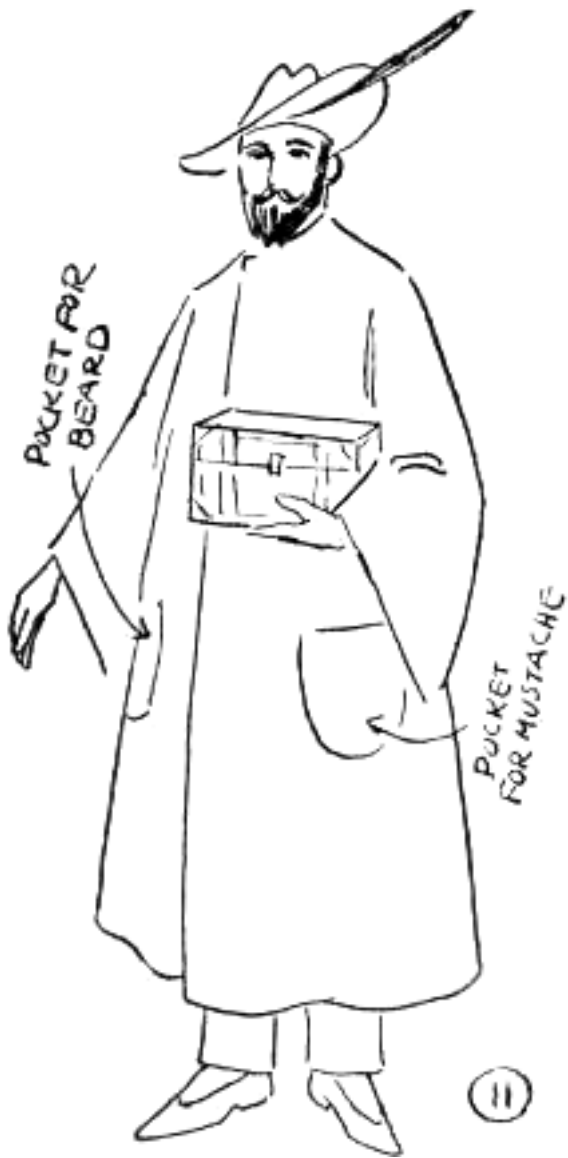
COSTUMES:

FOR PERFORMER:

1 - A dark cloak. Fig. 11 (also duplicate cloak).

2 - Black hat with red feather. Fig. 11 (also duplicate hat).

3 - Pair of pumps or oxfords that can be easily slipped off.

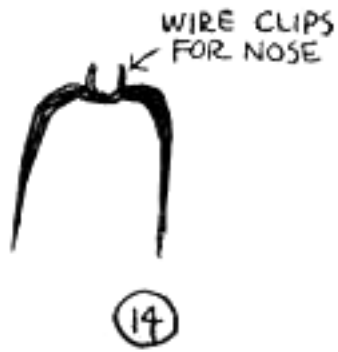


CHINESE
EYEBROWS
PAINTED ON
WIG

4 - False beard with mustache attached. Figs. 11 and 12. Should be a professional type of beard such as a doctor might wear. Mounted on wire for quick attachment over ears (also duplicate beard).

5 - Chinese wig with hat attached. Fig. 13. The front of wig comes down over eyebrows; Chinese eyebrows are painted on wig.

(57-7)



6 - Chinese mustache, with wire to be clipped in nose to keep mustache in place. Fig. 14.

7 - Dark trousers. Fig. 15.

8 - Chinese coat of sateen. Fig. 15.

9 - Pair of Chinese slippers.

10 - A white ghost uniform of white muslin consisting of helmet with two eye holes, a cloak, Fig. 16, and a pair of bootees, Fig. 17. There is a band of elastic in top of each bootee to hold them in place on legs.

FOR ASSISTANT ONE:

1 - Cat uniform made of black plush. Fig. 18. The paws have cloth on inside where palms of hands and bottom of feet come. There is a slit cut in palm of each paw so hands can be slipped through easily when necessary. Fig. 20. The helmet or head may vary as in Fig. 19, and he can wear a cat facial mask. The tail should be shortened or sewn against leg or fastened to back so it will be out of the way.

2 - A ghost outfit with bootees the same as performer has, Figs. 16 and 17.

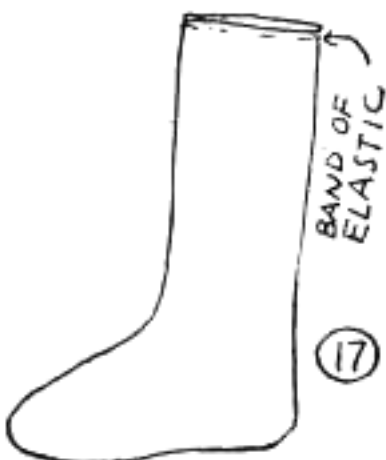
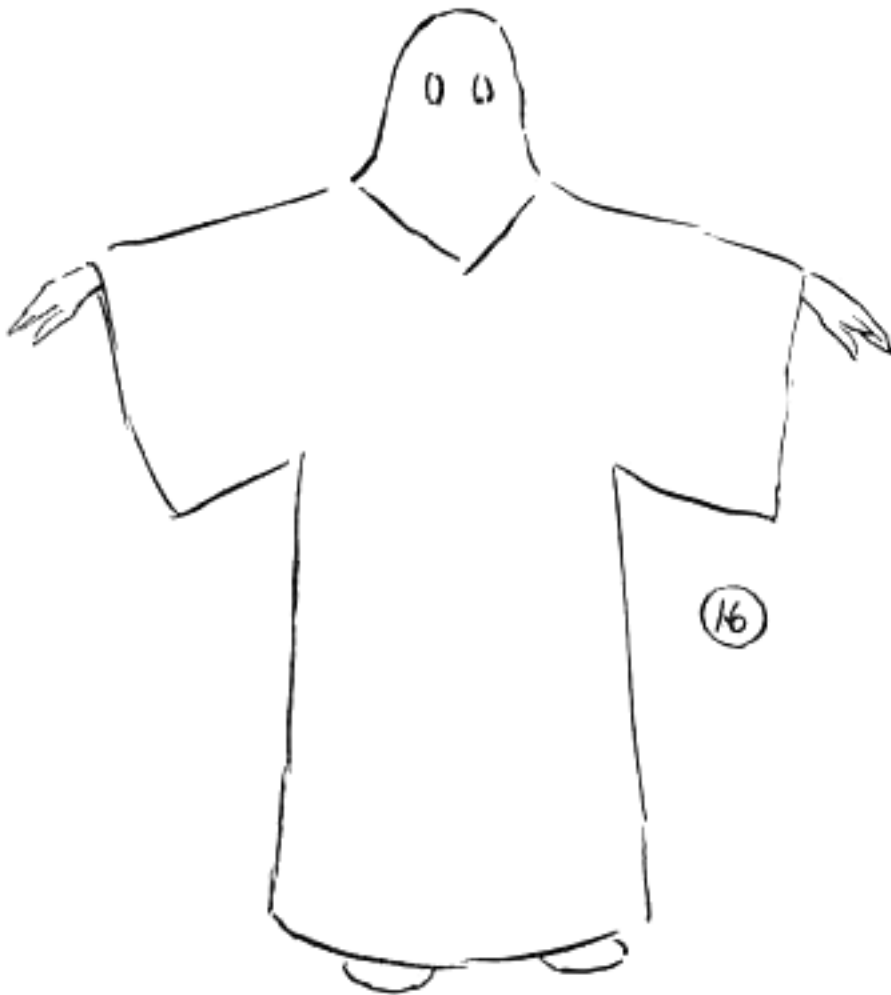
FOR ASSISTANT TWO:

1 - A cat outfit in duplicate of Assistant One's. The two assistants must look just as much alike as possible with the cat uniforms on.

NOTE: If you find cat uniforms too hard to get, you can use some other character instead of a cat, perhaps a monkey. You might buy or rent costumes from a professional costumer. Even a Chinese Pirate type would be good with eye piece over one eye, a bandage or handkerchief around his head. He must be an entirely different type than the other Chinaman.

Whatever type of character is chosen, the two assistants must be made up exactly alike.

(57-8)





19

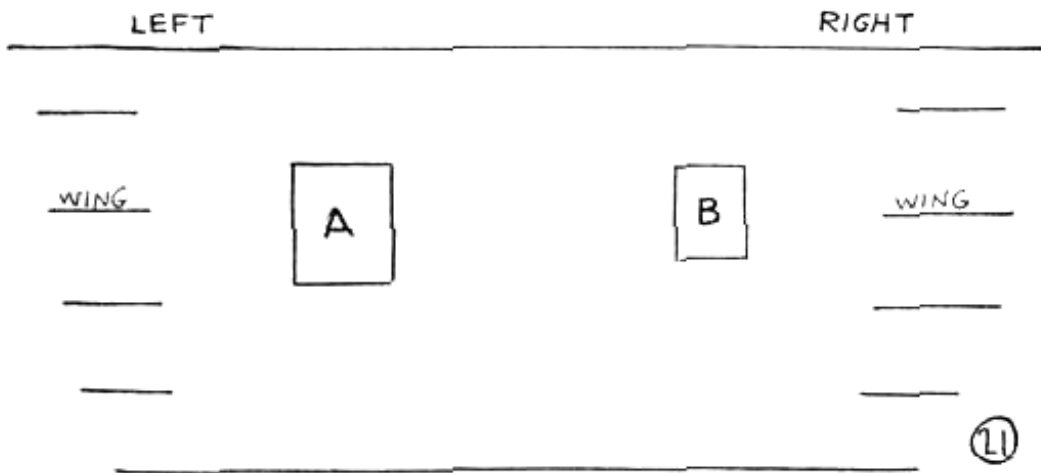


18



20

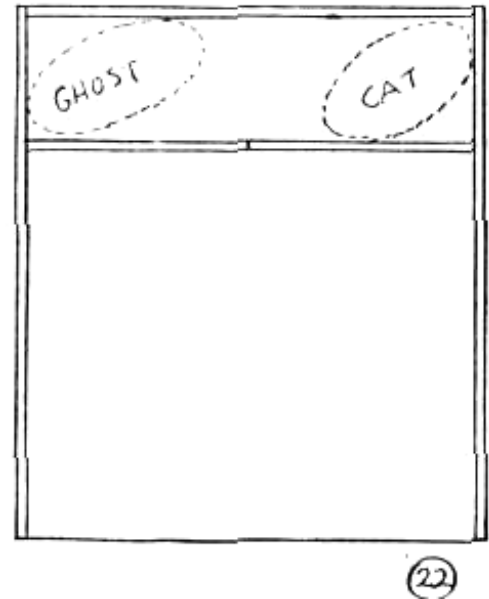
SLIT
CUT IN
INSIDE OF
PAW TO
SLIP HAND
THROUGH



GETTING READY TO PERFORM:

Fig. 21 shows stage arrangement and position of the cabinets. Cabinet A, the larger, is at the left, and Cabinet B, the smaller, is at the right.

To begin with, Cabinet B at right is empty. Inner door is pushed up against side of cabinet out of the way.



Inside of Cabinet A on the rear of inner compartment are small nails or hooks on which to hang clothes.

In Cabinet A the performer's ghost outfit is hung so it can be easily gotten at. Also the Chinese wig with cap attached. On floor are the Chinese slippers, at center, easy to get at.

Both the assistants are in the inner compartment of Cabinet A. Fig. 22.

Assistant No. 1 has his cat outfit on and over it the ghost uniform.

Assistant No. 2 has on the cat uniform.

The curtain of Cabinet A is open and audience can look in cabinet from the beginning. The doors of Cabinet B are closed.

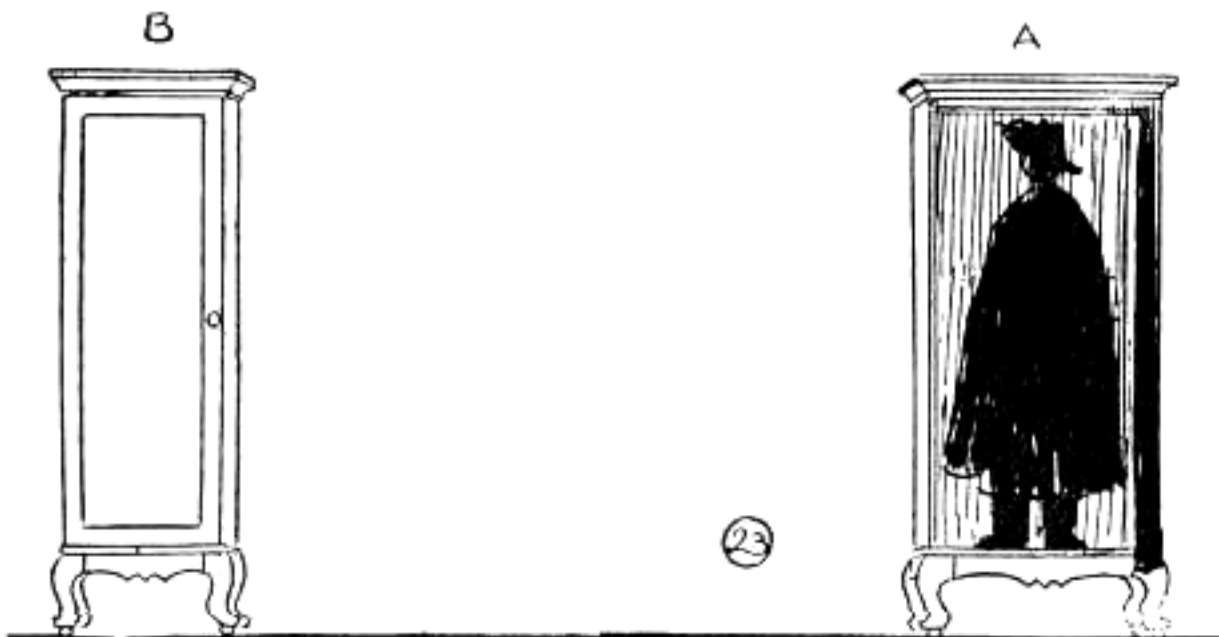
Performer is offstage, at left. He has on the Chinaman's coat. His regular dark trousers answer for Chinaman's later on. He wears pumps and carries feathered hat in hand. In his right pocket is the false beard and in his left one the Chinese mustache. He wears a cloak over the Chinese coat. He carries the empty treasure chest. A cloak, feathered hat and beard are on chair off stage at right near front wings. Also a regular coat he wears, and a revolver (22-caliber) loaded with blanks.

TO PERFORM:

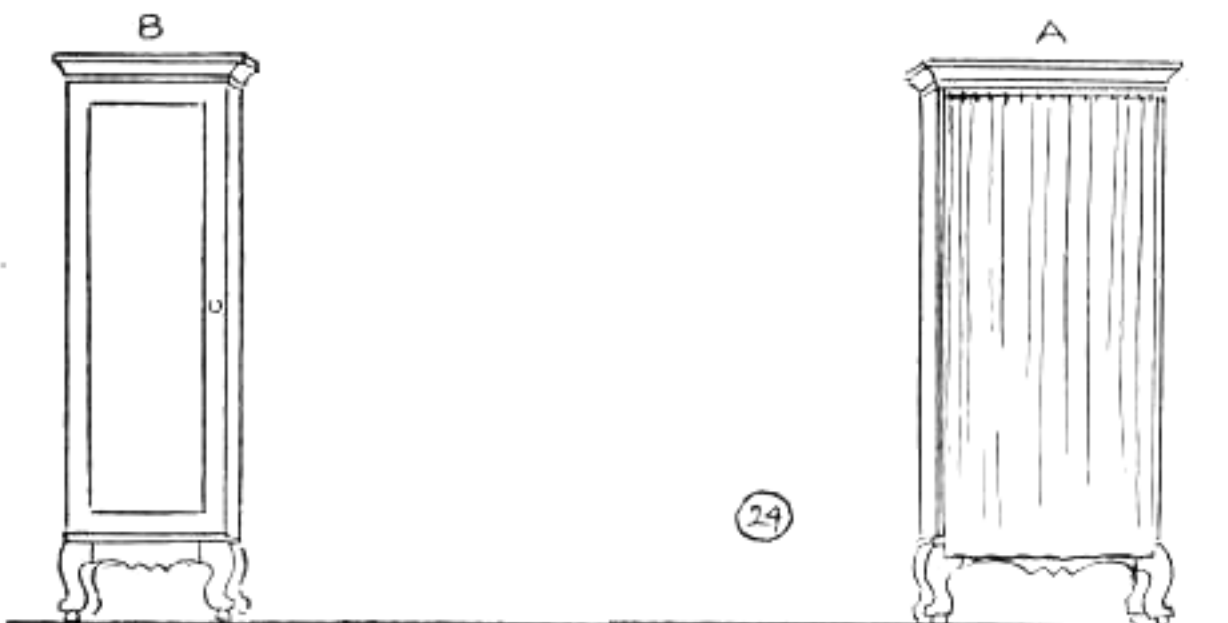
Curtain goes up.

You come out with cloak carrying treasure chest in left hand and feathered hat in your right.

You come in front of Cabinet B, and after slight bow of acknowledgment to audience to be sure everyone recognizes you, you place treasure chest on floor. From your right hand pocket remove the beard and adjust the wires over ears. Place hat on head.



Look at cabinet. Revolve it slightly so that audience can see there is nothing at rear. Place cabinet back into position. Pick up the treasure chest and, looking at it a moment, step into Cabinet B, Fig. 23. Your back is toward the audience.



When you enter cabinet, assistant No. 1 pulls cords at right and pulls curtain slowly shut. Fig. 24.

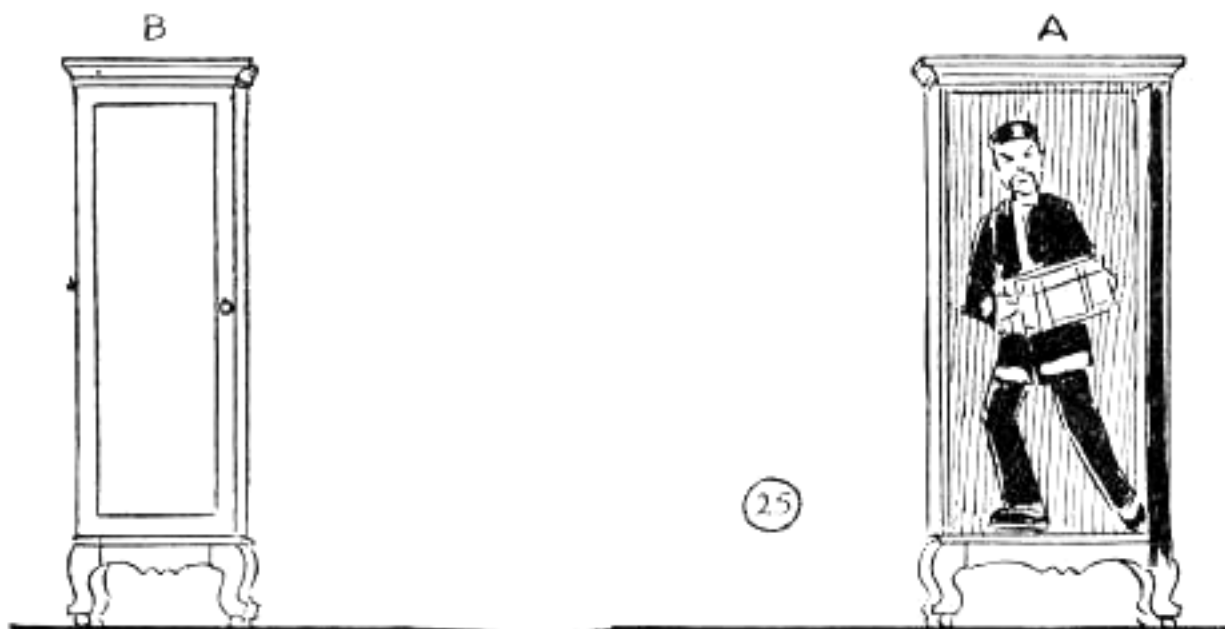
The moment curtain is closed, assistant No. 2 (the cat) opens door and hands you the Chinese wig and pushes Chinese slippers out.

You quickly place chest on the floor. Then remove hat and beard. Beard goes into right cloak pocket. Give hat to assistant. Remove Chinese mustache from cloak and place wire clips in nose. Remove cloak and hand it to assistant to hang on ready hook. Remove pumps or oxfords and quickly slip into Chinese slippers. Put on the Chinese wig by pushing front against forehead and then over back of head. Assistants get everything out of way as quickly as possible and close inner doors. You pick up chest and face front of cabinet.

Assistant No. 2 pulls cord at left and opens curtain.

Instead of the performer a moment ago in cabinet, audience now sees a Chinaman with the chest. Fig. 25.

(57-10)



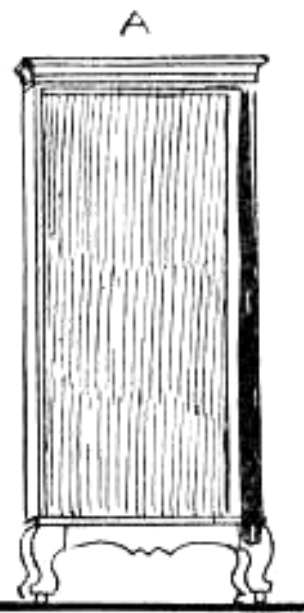
NOTE: This change should be well rehearsed so as to make the quickest change possible. If the assistants are trained to help you, you can speed matters. If you care to, when curtain is closed, a shot can be fired by one assistant through front peep hole in side of cabinet with small calibered revolver. And possibly a second shot. Needless to say, No. 22 blanks are used.

As a Chinaman, you can crouch a bit. Your disguise should lead audience to think you are a different character. You must lead them to think you have disappeared and Chinaman has taken your place and obtained possession of the treasure box.

You come down out of cabinet slowly, then look and go to left, then to right. Sort of slink and crouch along. You go over to Cabinet B and place



(26)



box on floor. Open front door of cabinet. Look inside. Step into cabinet and then push open back door and get down on floor at rear of cabinet. Look at inside of cabinet. Fig. 26.

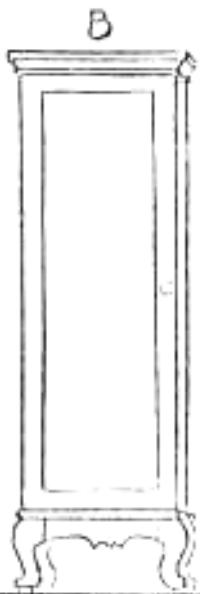


(27)



Close the back door and see that it is held tight with catch. You have hook on door to hold it secure.

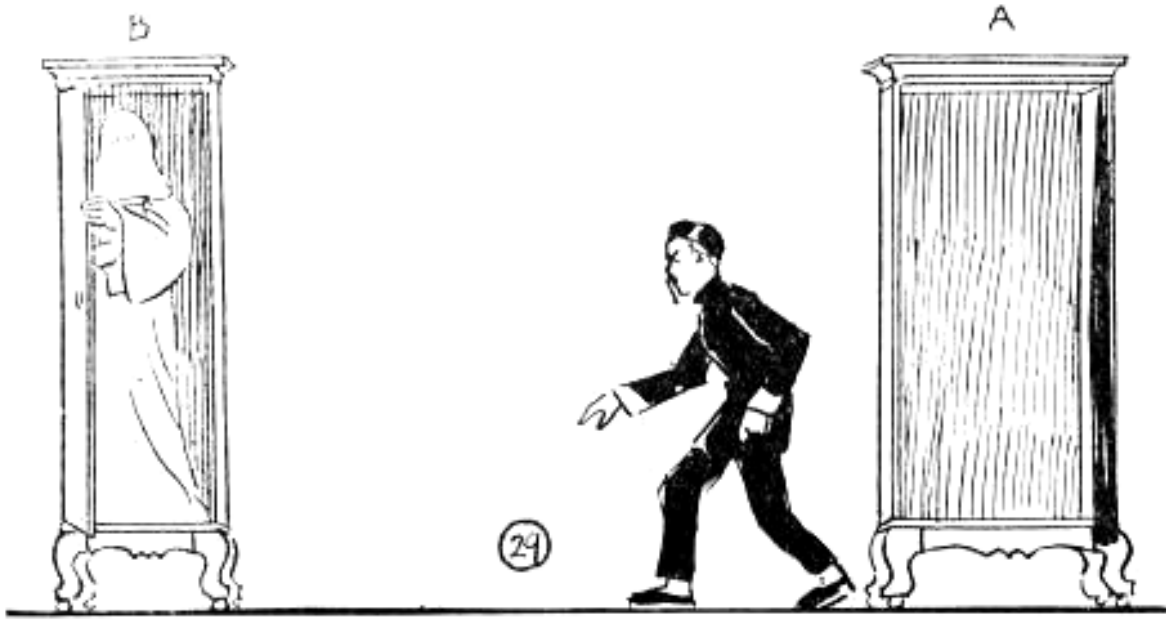
Come around right side of cabinet and, picking up treasure chest, place it in cabinet. Fig. 27. As you do this, the curtain in Cabinet A mysteriously closes and ghost gets into position in front compartment.



(28)

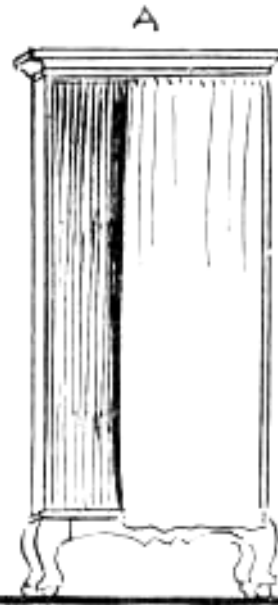


You close front door of Cabinet B and go over toward Cabinet A. You note closed curtain, then see it opening. You slink over to right side of Cabinet A while curtain opens revealing the ghost in the cabinet. Fig. 28.

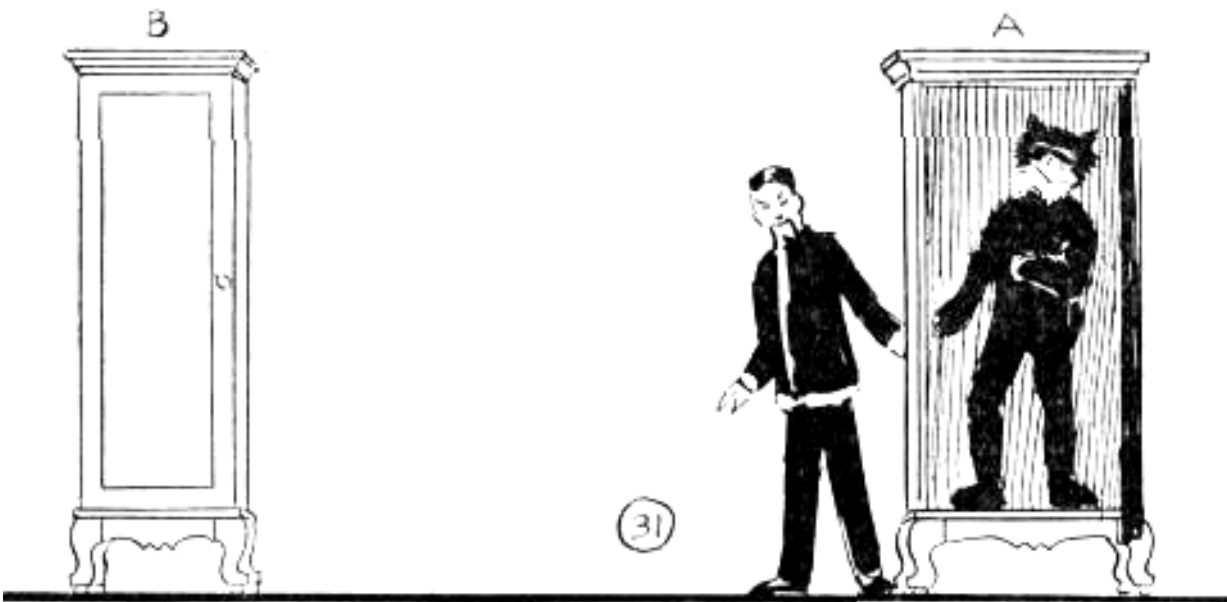


The ghost steps out of cabinet and, looking about, glides over to Cabinet B and opens the door and sees the treasure chest. He picks it up and looks at it, then gets into the cabinet with it, Fig. 29, and pulls front door shut. When front door is securely shut, he steps to rear of cabinet and places chest on floor at right while he pulls inner door across cabinet and in front of him.

(57-11)



You go over to Cabinet B (use a Chinese step with crouched position of body) and open door suddenly. Fig. 30. The ghost has vanished. You close door again. As you do so, the curtain in Cabinet A closes. Cat comes out of rear compartment and in readiness. You go again toward Cabinet A and see curtain closed. You go back to right side of cabinet as curtain opens and the cat is revealed. Fig. 31.



In this case cat will have to open curtain himself, as there is no one in rear compartment to control it.

Cat is somewhat crouched over. He looks about, gets down out of cabinet. He goes around the left side. The performer comes around the front side of cabinet cautiously. The cat goes to rear of cabinet and stage with you a few feet behind. Cat goes around rear of Cabinet B, looks it over and then around right of cabinet in

front and
then to
center of
stage.

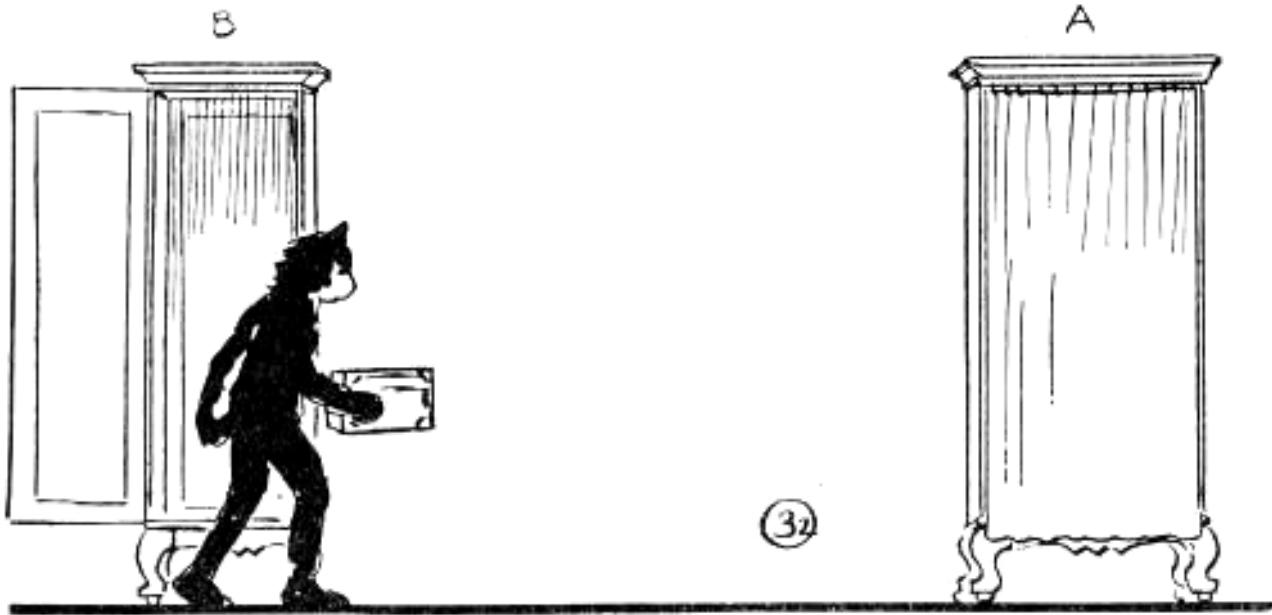
While all
this is going
on, the ghost
assistant in
Cabinet B
pushes inner
door back
into place
and then
removes his
ghost outfit
and places it
in the
treasure
chest,
hooking lid
securely. If
necessary,
have a
flashlight so
as to aid him
in his work.
This can be
permanently
fastened in
rear of
cabinet on
right hand
side and
covered with
cretonne.
Flash points
downward.
When through,
turn off
light again.

The ghost is
now a cat, a
duplicate of
the other on
stage.

When cat is
at center of
stage, he
hesitates and
listens, then
turns and
sees
Chinaman. Cat
runs into
Cabinet A and
pulls curtain
closed. He
then goes
into secret
compartment.
You look
about a
moment, then
rush into
cabinet by
lifting
curtain a
bit. Go into
inner
compartment.
Cat pulls
cord at right
side and
opens curtain
mysteriously.

You can give
a sharp
whistle as
you enter
Cabinet B to
give signal
to cat in
Cabinet B
that all is
well in a
moment, for
him to come
out.

(57-12)



Door of Cabinet B slowly opens and cat sticks his head out cautiously. The effect is that cat which disappeared just a moment before in Cabinet A has suddenly appeared in Cabinet B. Cat opens door and steps out. He is holding the chest of "money." Fig. 32.

The moment front door of Cabinet B opens, the curtain in Cabinet A is pulled shut. You come into front compartment. Remove the Chinese slippers and put on your pumps or oxfords. Over these slip the bootees. Remove Chinese mustache and wig and slip them into pocket of cloak hanging up. Put on the ghost cloak and finally the helmet. Assistant can help you.

While you are doing this and getting ready to appear as the ghost which vanished in Cabinet B, the cat from Cabinet B is having a good time with the treasure chest. He comes to center of stage between stage and

cuts up antics. He can kick up his legs and go round on all fours and cross his forelegs, then his hind legs. He can get a lot of comedy out of the right kind of antics, especially if he is well gotten up as a cat.

NOTE: In case another character is used instead of a cat, and not an animal, he can do investigation work then or some sort of a magic stunt to stall for time.



When you are set to appear as ghost, the assistant in rear compartment pulls cords and curtains open. You step down out of cabinet. Cat should have his back to you. You glide over to cat and stand beside him. He does not see you, but cuts up just the same. Fig. 33. The ghost standing beside the cat is a good chance for comedy because of the imaginative expectation of what cat's expression will be when he sees ghost.

Ghost touches cat on shoulder. Cat stops a

moment, but
still does
not see
ghost. Comedy
can be had by
having ghost
keep close to
cat and keep
at his back.
When cat
looks to
left, ghost
is over at
right. Ghost
touches cat
on other
side, then
shifts to
left side
again. Cat
turns and
sees nothing.
Ghost touches
cat on left
shoulder.
Finally cat
sees ghost
and makes a
bee line for
Cabinet B,
getting
inside and
closing door
quickly after
him. Cat
pulls inner
door in front
of him. You
go to Cabinet
B and quickly
open door
showing cat
has vanished.

(57-13)



39



In the meantime curtain has closed over in Cabinet A and other cat gets into front compartment. He looks through peep hole in cabinet and when ghost has opened door of Cabinet B, he sticks his head from out of Cabinet A pushing curtain only slightly aside without disturbing rings at top. He waves his left hand at ghost. Fig. 34.

Apparently cat which disappeared in Cabinet B has appeared over in Cabinet A.

Cat in Cabinet A drops curtain and goes to rear compartment. He pulls cord and curtain mysteriously opens revealing cabinet empty. Ghost comes over to Cabinet A in meantime and it is while he stands near it that curtain opens. He looks into cabinet and on each side. He gets into cabinet and looks around. While he is doing this in cabinet, the door of Cabinet B slowly opens and cat sticks his

head out and
looks
around. Not
seeing ghost
(for ghost
is looking
around in
Cabinet A at
the time)
cat comes
and gets the
treasure
chest and
rushes back
into Cabinet
B and closes
door. The
ghost comes
out of
Cabinet A,
still
looking
around, and
goes to get
the treasure
chest, but
finds it
gone. He
goes to
Cabinet B
and opens
the door,
but it too
is empty. He
closes door
again, goes
around the
right side
of cabinet
and off the
right side
of stage at
rear.

You are now
offstage. So
you come
around to
front and
quickly
remove the
ghost outfit
and
Chinaman's
coat,
slipping
into your
own coat, if
handy, then
don the
beard,
feathered
hat and
cloak
similar to
the one you
first
entered
cabinet
with.

While you
are
changing,
the door of
Cabinet B
opens and
cat comes
out with the
treasure
chest. He
looks around
and starts

toward
Cabinet B.
His exit
from cabinet
and movement
about stage
should be
somewhat
slow.

When cat is
over near
Cabinet A,
he places
treasure
chest on
floor, then
looks around
at Cabinet
A. He waves
his hand and
curtain
closes. He
waves his
hand and
curtain
opens. He
waves again
and it
closes. This
is to stall
for time
while you
are changing
costumes.
Finally you
rush in from
right side
of stage and
fire pistol
in air. The
cat turns,
sees
performer
and lifts
curtain and
darts into
Cabinet A.
He goes into
rear
compartment
and curtain
slowly opens
showing the
cat is gone.
You come
over, pick
up treasure
chest, bring
it forward,
then remove
your hat and
beard,
showing
audience
that it is
you. If you
care to, you
can also
slip off
cloak or let
it fall
open. You
bow as
curtain
descends.

At the
FINISH, you
stand alone
as in the
beginning,
and the

cabinets are
both
apparently
empty.

(57-14)

NOTE:

If it is just as easy for you to use four people in the illusion instead of three, you can vary the modus operandi a bit. You could have another assistant play the part of the Chinaman. He, together with ghost and cat, is hidden in secret compartment of Cabinet A. When you enter cabinet at first and curtain is closed, the Chinaman comes out and you take his place in rear compartment. This allows for quick change. When it comes time for you to appear as ghost, you can dress easily in front compartment with curtain closed. You hang hat and cloak in rear of cabinet. Or, if you care to, you can come out of cabinet as an entirely different sort of character and go off the stage. The Chinaman in that case goes through the routine of finally becoming the ghost.

There are so many possibilities in an illusion of this kind that an ingenious magician can work out a most mystifying routine of action to prevent slowing down of the illusion. There must be something going on throughout the illusion for audience to see. When no-one is on stage, the time should not be too long, as every second seems like many.

THE MYSTERY OF THE THREE GHOSTS

This is another effect based around CABINET A, as already described in the "Chinaman, the Ghost and the Cat." It is based on one of Servais LeRoy's pleasing illusions. In it you have a mystifying production and at the finish an excellent transformation.

EFFECT:

Performer places on a mask over eyes and gets into a cloak with headpiece made up to represent Mephistopheles. He calls attention to a cabinet which is open in front. There is, however, a curtain which has been pulled open. The cabinet is revolved and placed in position again so audience can freely see inside that cabinet is empty. Performer steps into the cabinet and takes a white sheet that girl assistant hands him. He holds it up in front of him a moment when suddenly a figure forms under the sheet and moves away from cabinet covered with sheet over to left side. Another sheet is given performer, who holds it up while another figure appears and likewise covered goes to right side. Still another sheet is taken and held in front of performer when another figure appears which under sheet comes down in front of cabinet and midway between the other two covered figures. Performer in cabinet closes the curtain in front of him. Mysteriously the curtain opens, but performer has vanished - the cabinet is empty. Finally figure under sheet at left rises up from crouched position, removes sheet and shows himself to be one of the assistants. The figure at right side rises up and shows herself to be one of the girl assistants. Then the center one rises up and removes the sheet. It is the PERFORMER HIMSELF. He removes the mask, cloak and head piece.



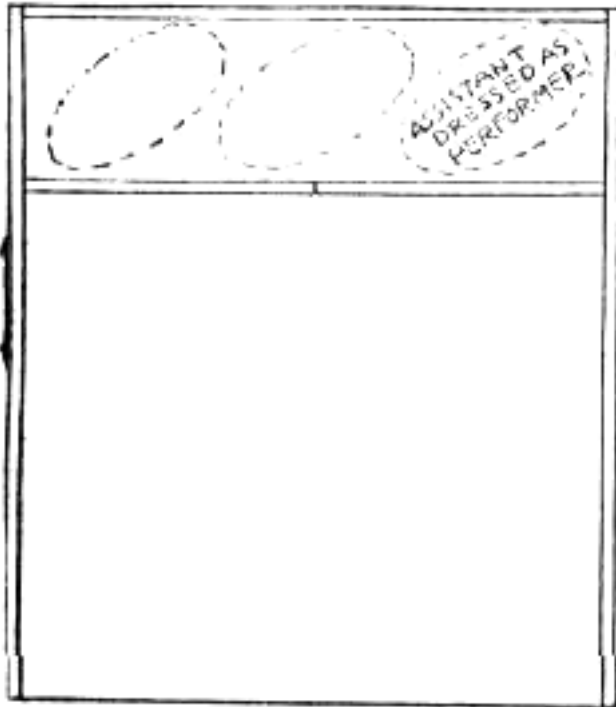
PARAPHERNALIA:

1 -- The Protean Cabinet of LeRoy, already described.

2 -- Three large sheets, big enough to cover a person when he crouches a bit without exposing the person beneath. They can be white or of varying colors, say pink, white and light blue or orange, respectively. It would add color.

3 -- Two red cloaks with head piece attached to give a Mephistopheles atmosphere. Also two red masks. Fig. 35 shows the costume.

PREPARATION:



You will require two male assistants and two female ones to work this version. However, there is no reason why it cannot be varied by using all men assistants. One can be eliminated by having sheets handy on table and then picking them up yourself each time instead of having them handed to you. One of the assistants must be as near your size as possible, as he must double with you.

In setting the illusion the assistant doubling for you puts on the Mephistopheles cloak and headpiece and the mask. He steps into secret compartment of cabinet, together with man and girl assistant. Fig. 35A.

Performer has his cloak and mask handy.

TO PERFORM:

Cabinet is in position with opening toward audience. The curtain is opened.

You enter and put on the Mephistopheles cloak, then mask, and adjust the headpiece over your head.

You revolve the cabinet around to show that nothing is concealed on the back, and bring cabinet to original position with opening toward audience.

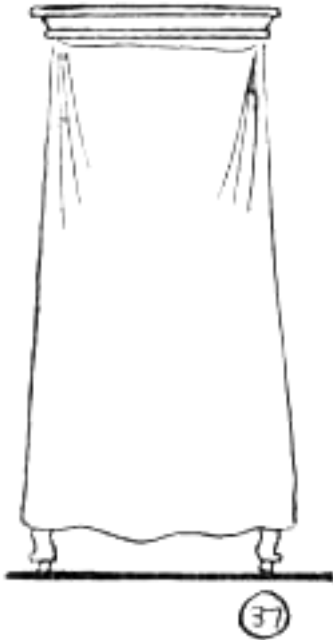
You step into cabinet and girl assistant hands you a sheet. Fig. 36.



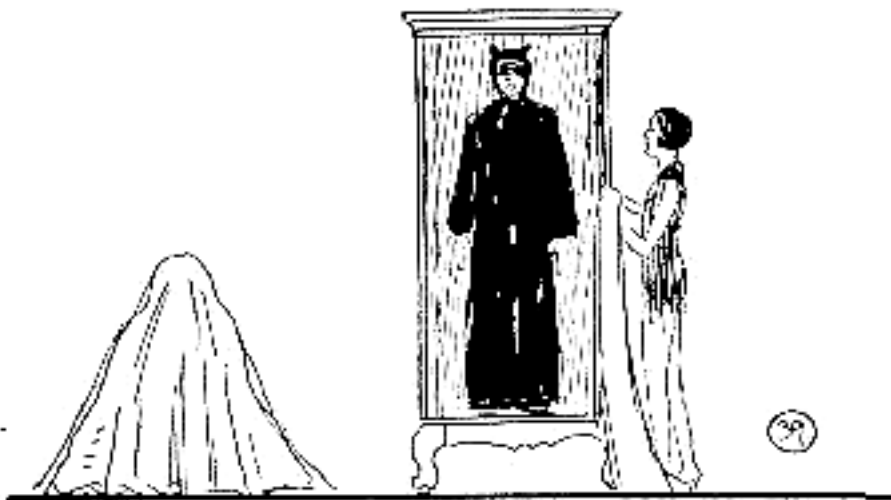
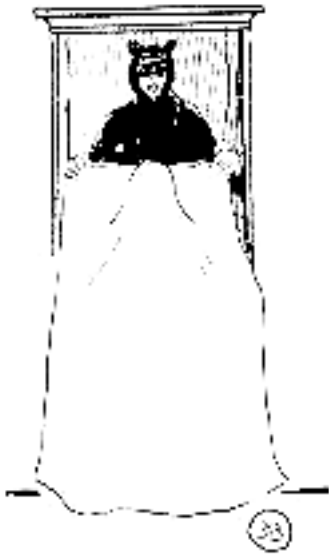
36

You show it freely, then open it up and hold it in front of you, at same time covering opening of cabinet, Fig. 37.

(57-16)



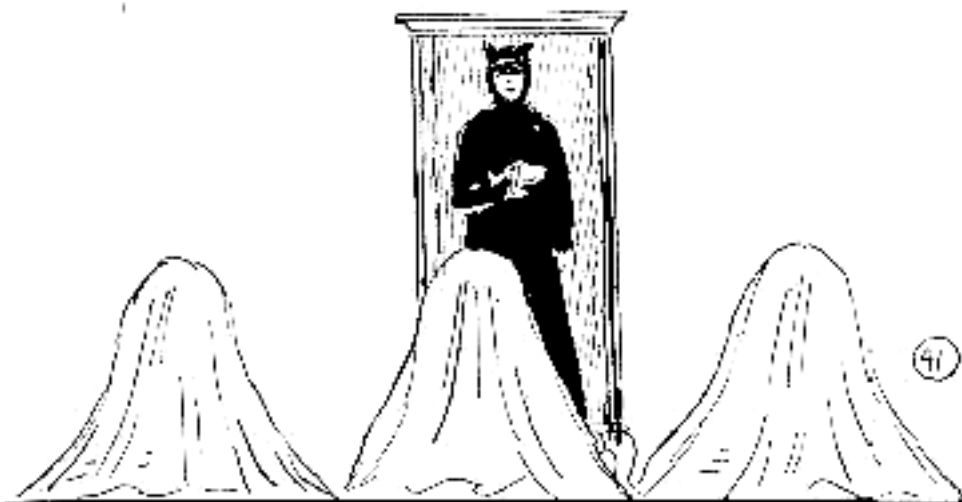
37



You give signal to male assistant to come out of rear compartment. He comes out and steps in front of you in crouched position. Then you let down sheet on him. Fig. 38. Let bottom of sheet dome down on the floor. Assistant steps down on floor behind sheet and crouches down. Sheet is dropped over him completely hiding him. The audience is to be mystified as to just what is under the sheet- Assistant moves to right side of cabinet and somewhat in front. Fig. 39.



You take another sheet and open it up in similar fashion to cover opening of cabinet. You signal the girl assistant in rear compartment, who comes forward and is placed under sheet. Be sure bottom of sheet comes down to floor- She crouches down and is covered by the sheet. She moves to the left and front of cabinet. Fig. 40.



You hold up another sheet over opening of cabinet and signal your double to come forward. He takes hold of the sheet. You release your hold. The sheet is lowered with bottom on floor. You step down onto floor, crouch down and your double covers you over. You come forward in crouched position to center. Fig. 41.

Your double in cabinet pulls curtain in front of

him. Then he exits into rear compartment and pulls the cords which open the curtain. Or curtain can be opened by girl assistant.

The assistant at right side raises up and removes the sheet covering him.

The assistant at left side raises up and removes the sheet covering her.



Then, with all eyes of audience on the central figure, you raise up and remove sheet showing the figure to be you, who just a moment ago apparently vanished in the cabinet. You quickly remove mask, headpiece and cloak, Fig. 42.

The transformation and appearance of performer at the finish is quite unexpected and startling.

LESSON 58

"THE PHANTOM OF THE CIRCUS"

An odd, mystifying illusion with appearances and disappearances ending with an unexpected finish.

Here is another illusion with a pantomimic story blended into it that makes it an excellent finish to a magical program.

(57-17)

LESSON 58

In your last lesson I initiated you into the possibilities of pantomime magic and the working out of a story or routine along with it.

In this lesson I will continue the work and present a novelty pantomimic routine under the heading of "The Phantom of the Circus."

It involves only one illusion cabinet, a parlor screen, a chair, costumes and a few small properties. It is not difficult to perform and has an unexpected finish so important in modern day presentations. There is more or less of the dramatic until the finish and then comedy makes an unexpected appearance. The audience is aroused throughout the action of the illusion as to just what the solution will be, and when the solution presents itself, it is so different from what an audience would expect.

As a magician I trust you will get the idea of romancing an illusion and building a breathing, living story into inanimate illusion paraphernalia. Not only illusions, but the smallest of pocket tricks permit of romancing. Many times the proper story will take a small insignificant piece of magic and place it in the feature class.

After all, you are selling your magic to the audience and your success depends on how well you sell it. The better the packages it is put up in, the greater the sales.

In connection with your study of romance in magic, I wish you would study the advertising pages of our high class magazines and see how advertising men take commonplace articles and build them into an environment of unusual sales interest. There is a dominating environment placed about the article that makes us believe that we would like to possess it.

Many a good article has gone begging until a good advertising man got a hold of it and breathed an interesting romance or story around it.

The stage offers great possibilities for illusion material of a different sort and material, daring and different, that sweeps an audience away in an avalanche of emotion. The problem of the producer is always, how to stimulate new interest and greater interest.

The professional wants interest at every moment. He knows the danger of lagging moments. The untrained amateur tires an audience because of the long waits between points of interest.

For example, go into your high class city theatre and note the careful routine and timing of a show, then go into a small town and notice an amateur show with its long waits between acts and the various bits.

I want you to be professional and sustain interest. I want people to talk about the excellence of your work and want to see you perform again. I want people going away "tickled pink" that they came to see you, and then go out and peddle mouth to mouth the wonders of your work. It may take time and care on your part, but isn't it worth it?

THE PHANTOM OF THE CIRCUS

EFFECT:

Near the center of the stage is a cabinet about three feet square and six and a quarter feet high. It is supported about a foot off the stage by a platform extending a bit around the cabinet. The cabinet has a door in front which opens outward and two doors in the back, the two doors together being the same size as the one larger door in front. The cabinet is covered with striped canvas such as is typical of the circus awnings and smaller tents.

The scene opens with a policeman who enters strolling along easily, swinging his club. He sits down on a chair a few feet at right of the cabinet and giving a yawn nods his head and appears to start taking a nap.

Suddenly a scream is heard in the cabinet. The policeman jumps up and looks about. He rushes over to the cabinet and opens the front door. On the bottom of cabinet is a circus girl, slumped up and motionless. Policeman examines her and finds her to be dead.

He closes the door a moment. By seeming luck a doctor happens to be passing by. Policeman motions to doctor and takes him to cabinet to see the dead girl. He opens the door but the cabinet is empty. The back doors are opened and both make a search for the girl's body. Not finding her, they again close the doors of cabinet and stand perplexed. To make sure, the policeman opens the front door again. There stands a clown peacefully smoking a cigarette. Policeman grabs his arms and leads him from the cabinet.

The doctor out of curiosity enters the cabinet and closes the door after him. There is a cry for help in the cabinet. Policeman opens door and cabinet is empty. The clown gives a derisive laugh. Policeman, perplexed, pushes door shut again. Suddenly a hand reaches through panel in door and removes policeman's hat and pulls it into cabinet. Policeman opens door and finds cabinet empty. His hat is hanging on wall of cabinet. He replaces hat on head again. When his back is turned, the clown quietly closes the door of cabinet, leaving policeman inside cabinet. Suddenly hands appear through small doors of various parts of cabinet. Clown laughs. There is a commotion inside cabinet. Door of cabinet suddenly swings open and policeman steps out, his hair mussed and his coat on wrong side out.

He draws a pistol from his trousers pocket and points it at the clown and forces him over to a parlor screen a few feet away from the right side of cabinet. The clown is forced to hide himself with the screen which is automatically shown to contain no one else.

Policeman backs over to cabinet and raises his hand with pistol. The pistol is flicked from his hands and disappears in cabinet. Policeman looks about the cabinet and readjusts his coat to normal condition.

Suddenly from behind the parlor screen comes an odd looking figure of a pirate. He folds up the screen; then suddenly draws a pistol and points it at the policeman. The door of cabinet opens quietly revealing the clown, who quietly steps out, closes the door and slips off the stage.

The pirate forces the policeman over to front of the cabinet, opens the door and makes him enter. He follows him inside and closes the door after them. Suddenly the door in front door of cabinet opens and a hand with a dagger is thrust through the opening. On the dagger is a card or paper with writing. The dagger is thrown on the floor and sticks in an upright position. The small door closes again.

The large door of cabinet opens and the doctor sticks his head out. After looking about he opens the door and steps out. There is no one to be seen in the cabinet. He closes the door again and noticing dagger with message, picks it up and reads it. He exits at the left of cabinet and goes offstage.

The cabinet door opens again, revealing the policeman. He is searching about cabinet for a clue of some kind. He opens the back doors again and shows the cabinet to be truly empty with exception of himself. He closes the back doors and then the front one.

Perplexed he sits down on the chair at the right of cabinet and meditates, his head down and eyes closed.

From the right side of stage the performer and girl assistant enter talking merrily. It is the same girl who was supposed to have been killed in the cabinet.

The policeman sits suddenly upright and looks at them. He gazes at them in amazement. He gets up and touches the girl on the arm to see if his eyes are deceiving him. He does not understand and wants an explanation. The performer and girl do not seem to understand what he is talking about. He tries to explain.

Performer tells policeman he is either intoxicated or has been dreaming because there is nothing wrong with the cabinet except that it contains his private bar. So he goes over to the cabinet and opens the door revealing a counter with bottles and glasses on it and a bartender standing behind ready to serve.

CAST OF CHARACTERS: (3 males, 1 female)

The Policeman ----- Man assistant

The Circus Girl ---- Lady assistant

The Doctor ----- The performer

The Clown ----- 2nd man assistant

The clown is duplicated by lady assistant who plays the part of the circus girl.

The Pirate) Played by the same man assistant

The Bartender) who takes the part of the clown.

PARAPHERNALIA:

1 -- The Circus Cabinet

2 -- A three-sided Parlor screen.

3 -- A kitchen chair or stool.

4 -- Costumes

5 -- Two pistols.

6 -- Dagger with piece of paper or card thrust on blade up close to handle.

7 -- Three or four beer and cordial bottles and the same number of glasses typical of a bar.

PREPARATION:

1 - The Circus Cabinet:

Here is another piece of cabinet apparatus capable of producing many plots of vanishing appearing or transforming people. It is quite simple in construction and painted up with the red and white, or blue and yellow striped awning to give it a true circus effect.

Fig. 1 gives a general idea of the cabinet mounted on a wooden platform and so raised above the floor that the spectators can see under it.

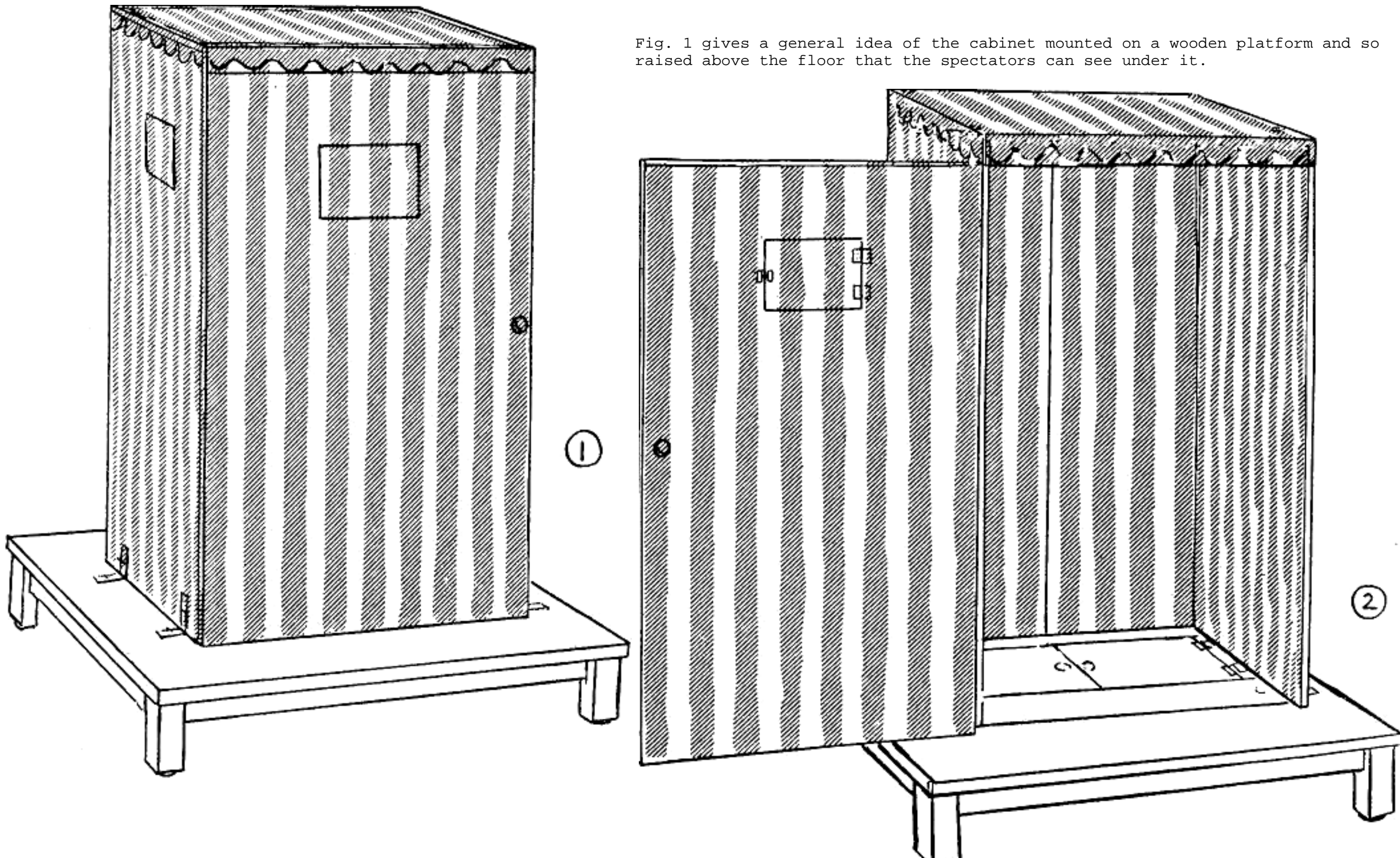
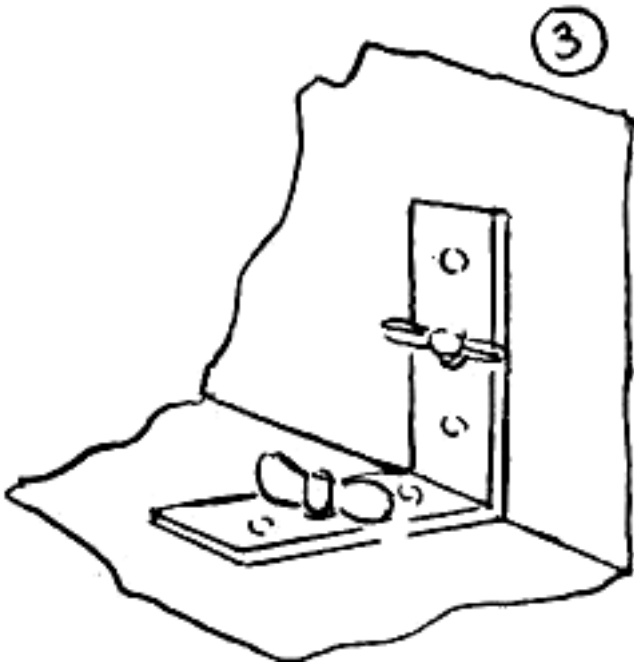


Fig. 2 gives another view of the cabinet with the front door open. You will observe that in the front door is a smaller door on hinges and with a catch. It opens and closes from the inside at will. There is also a similar door on right side of cabinet as can be seen in Fig. 1.

(58-5)

The walls, top and doors of the cabinet can be made of wallboard or of three-ply lumber or each wall, door and top could be a frame upon which is tacked awning on both sides.

Three-quarter-inch lumber about three inches wide of light material would be excellent for frame. It should, however, be well reinforced in center and in the corners.



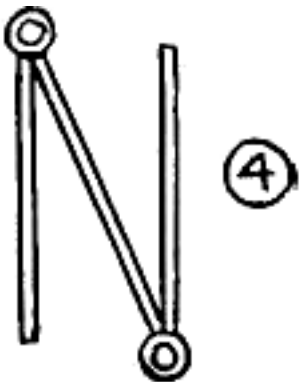
Each side wall is supported to platform by two or more iron clamps or angles and held in place with bolts and wing nuts. Fig 3. Also shown in Fig. 1. Wall could be supported inside as well as outside if necessary.

The top is fastened to the top of the two side walls by bolts extending from the top of walls through holes in top, and then top held in place securely by wing nuts.

The front door is hinged to front edge of right wall. The right side of stage, remember, is governed as you stand on stage and face audience. It is the actor's directions and not the audience's.

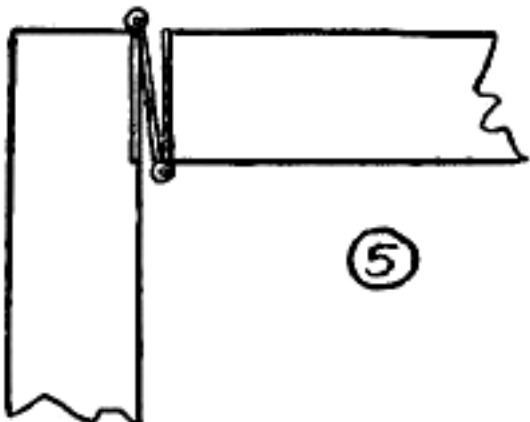
Pin hinges are used so that pins can be readily removed for packing. Have hinges well oiled so as to operate noiselessly.

There are two rear doors, each door being one half the size practically as the front door. Whereas the front door is hinged so as to swing outward, these two rear doors are hinged specially to swing both inside and out. Any good carpenter or cabinet maker can fix this for you if you have difficulty yourself.



To accomplish this, you can use a special type of hinge as is shown in Figs. 4, 5, 6, 7. Fig. 4 shows plan of hinge. Fig. 5 shows it hung at right angle to wall. It is pulled out a bit from wall to show position of hinge. Fig. 6 shows door opening inward and Fig. 7 the door opening outward. A hinge should be hung near top and bottom of each rear door.

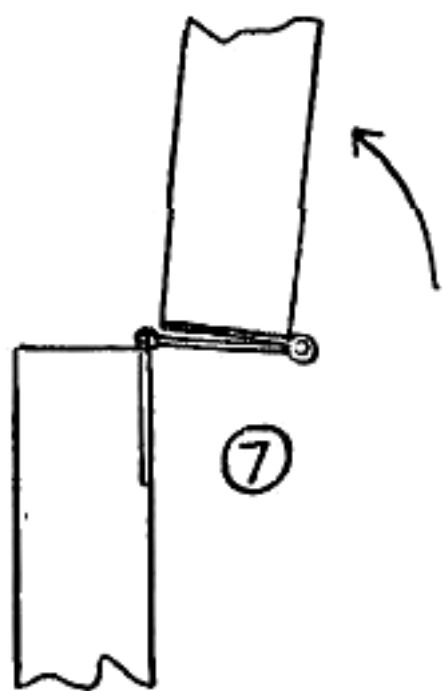
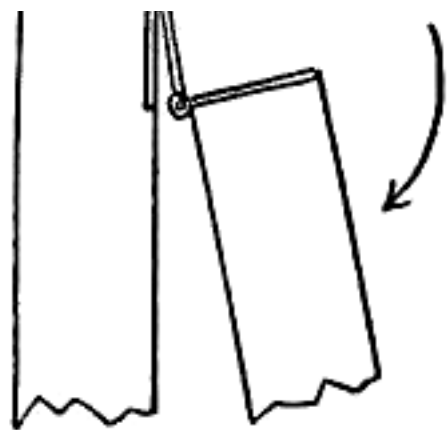
In hanging doors be sure that they are raised far enough off of platform to swing easily. Also be sure that proper knobs and catches are on doors to assist in opening and closing. In emergency the rear doors can be made to swing inward only.

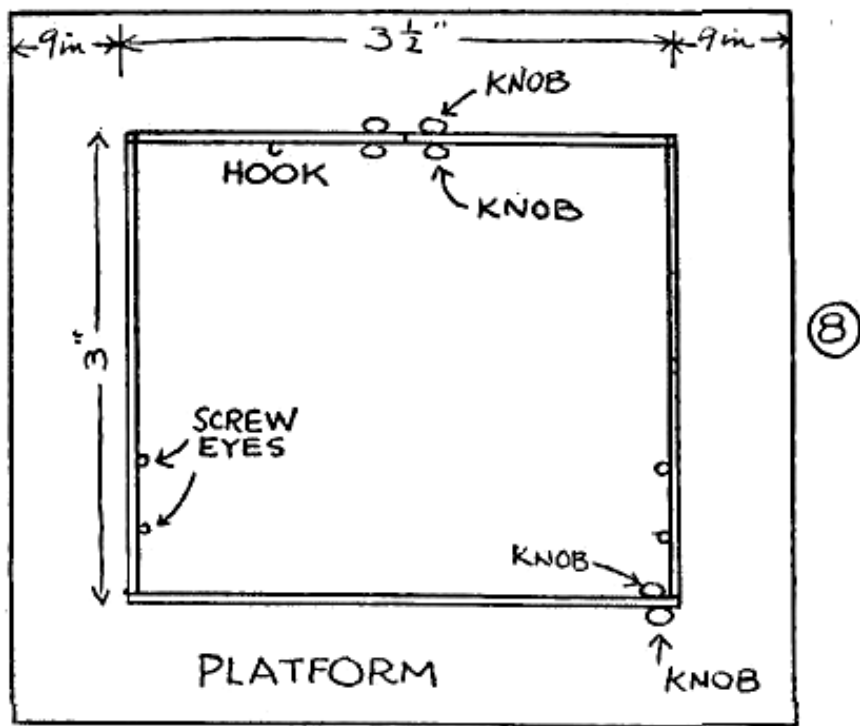


The cabinet proper is about six feet high, or a trifle more so if characters are very tall. It is 3 1/2 feet wide and 3 feet from front to back.

(58-6)







The platform extends 9 inches out from the cabinet on each side. Fig. 8 gives a cross section birdseye view.

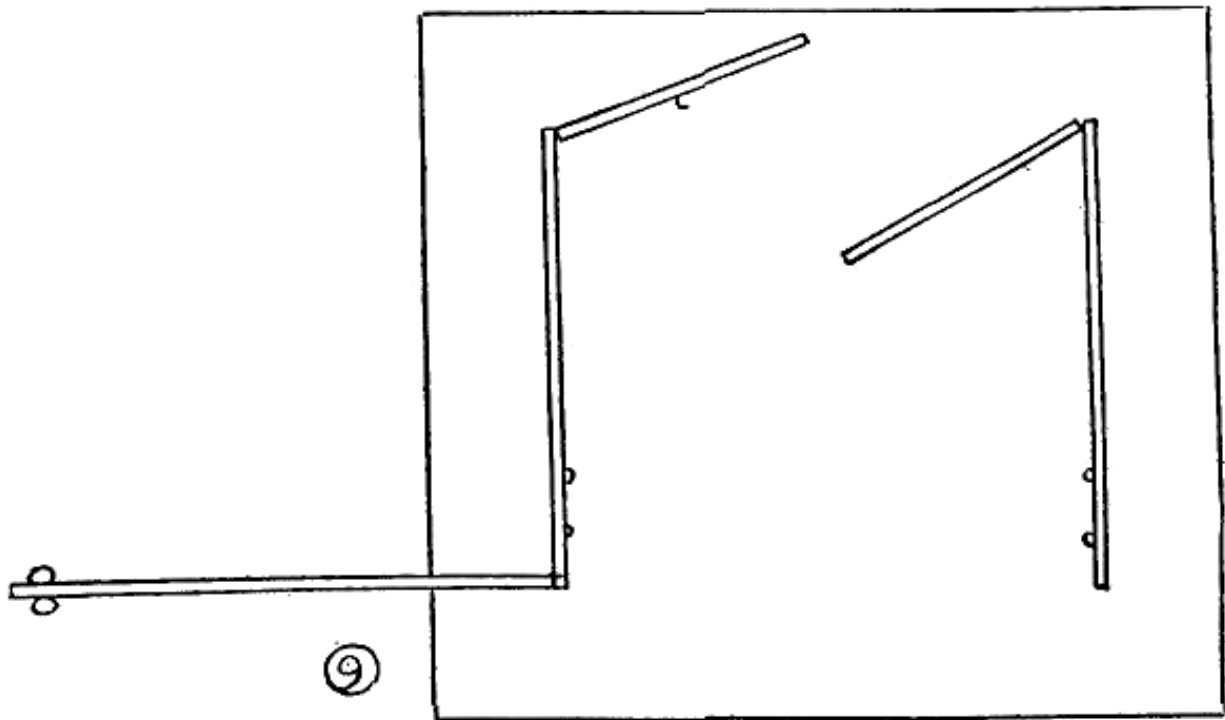


Fig. 9 is another similar view but with doors of cabinet open.

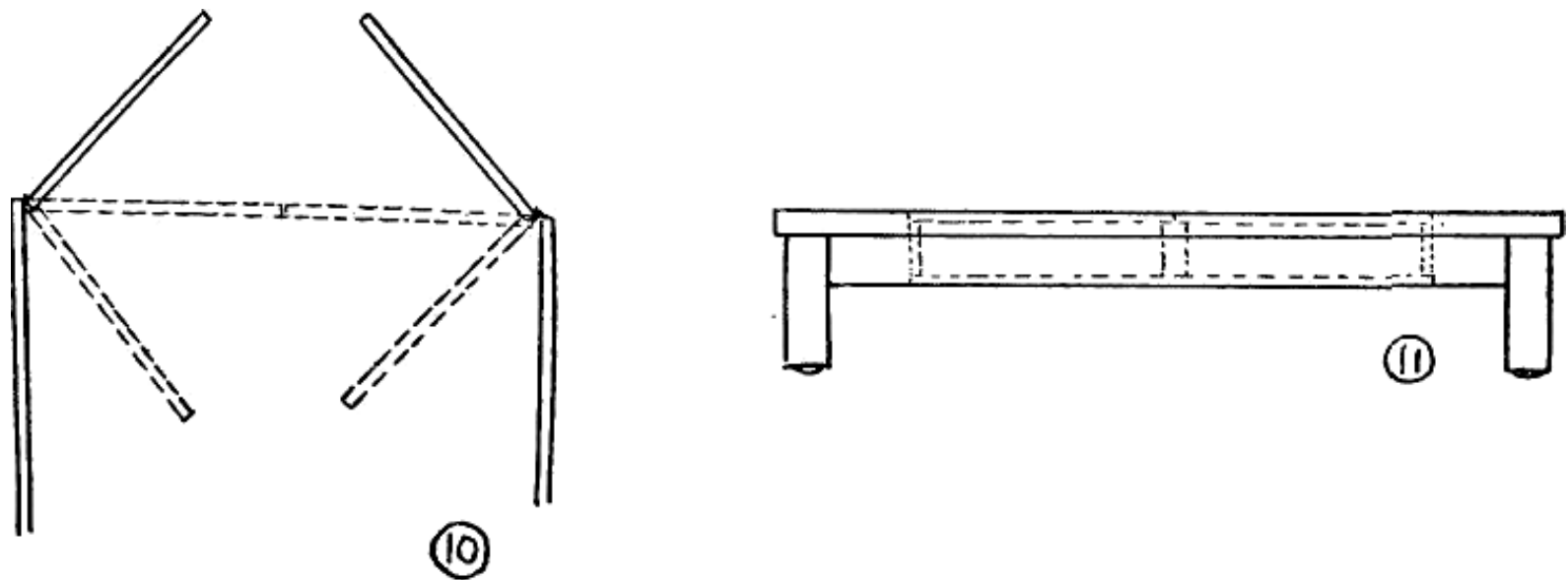
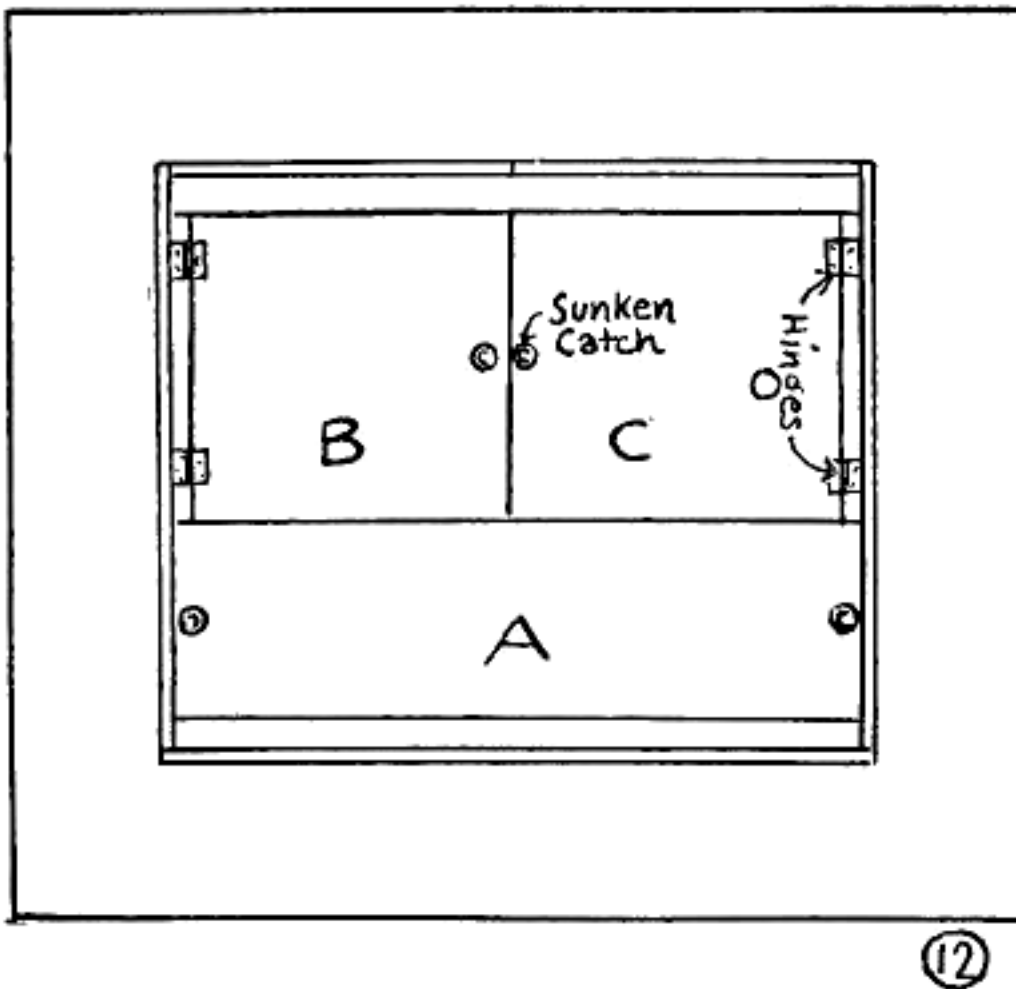


Fig. 10 shows position of rear doors of cabinet opening in and out.

Fig. 11 gives another view of platform. The platform proper is supported by four legs and the height from bottom of each leg to top of platform is from 12 to 14 inches.



(12)

On the bottom of each leg should be a metal floor piece so that cabinet and platform can be pushed easily over floor.

The platform acts not only as a support for the awning type cabinet, but is also used to hold various costumes and properties as required. There is a space about five inches deep in platform. Fig. 12 shows top view of platform with cross section of cabinet and three doors which help form top of platform. Door A is really only a foot board laid across. Sunken handles are near each end so it can be readily picked up. On the front of this board all the way across an opaque piece of cloth is tacked, the opposite end of cloth being tacked down into bottom of compartment under this board A. When the board is raised up about 39 inches and laid flat over screw eyes on each side of cabinet, Fig. 13, the cloth is stretched taut and board is flat and held in position by resting on the thumb screws, - it acts as a counter or bar later on in the illusion.

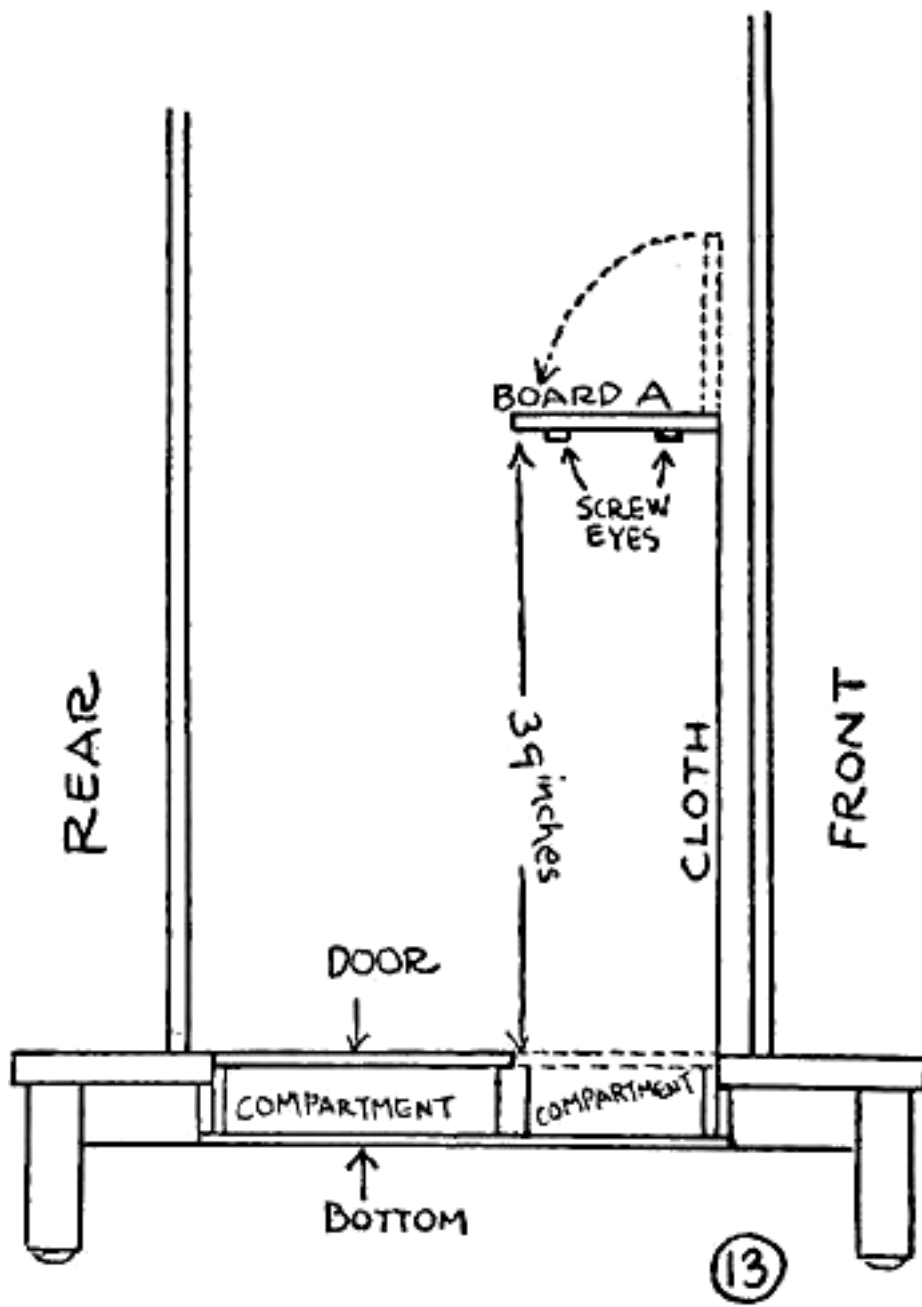


Fig. 13 also nicely shows how compartments are arranged, each having a boarded or metal bottom. Wood pieces are used

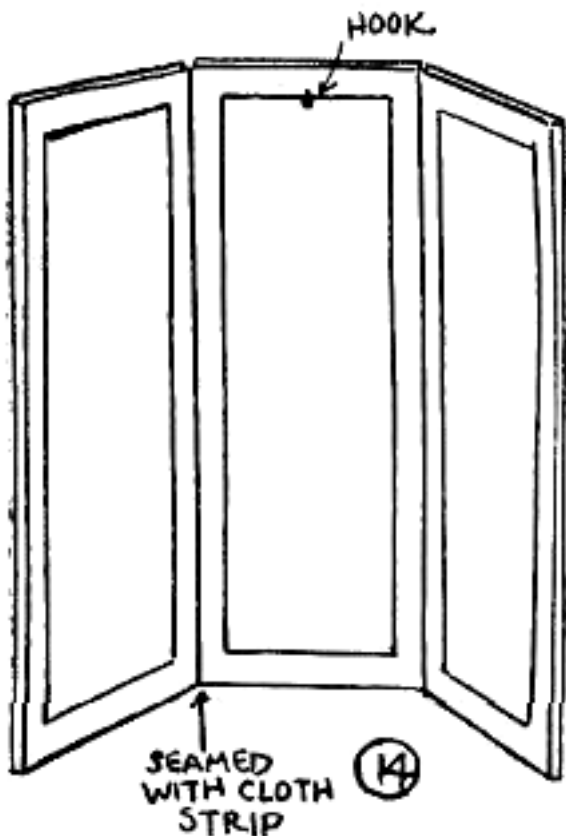
on me sides so as to hold Board A in place when settled down on platform or the doors B and C.

The doors B and C each have a sunken catch or handle and have their hinges near walls of cabinet. While performer is standing on Door C he can open Door B and vice versa.

Each compartment is separate. A two-by-four or two-by-five separates compartments B and C at the same time allowing support for doors at center of cabinet.

Floor of cabinet should be painted suitable color to hide any inkling of trickery or doors to compartments.

There should be no difficulty in understanding this or in building as in reality only common sense is needed. You must have three compartments for costumes and properties. Each compartment is covered with a door or board which easily lifts up and gives access to materials in compartments. The doors must be supported well enough underneath so performer can easily stand on them, using them as the top of the platform.



2 - A Parlor Screen:

This is merely a three-sided parlor screen such as sold in nearly all department and furniture stores. Fig. 14. Care should be taken to fasten a strip of cloth where screens come together so that spectators cannot see what is going on behind the screen. The cloth should be glued or tacked to inner side of each fold. On the inside panel near top drive a nail or place a small hook so that clown costume can be hung on it at the proper moment.

3 - A Kitchen Chair or Stool:

Just a chair or stool such as is used in the kitchen is all that is necessary. Even a box could be used in emergency.

4 - COSTUMES

Policeman - The usual policeman's costume with cap. Fig. 15. A club can be also used to add to the character.



The Circus Girl - A rather snappy dress similar to one in Fig. 16 or even a costume of the aerial performer, bareback rider or fancy costume suggestive of the circus. The costume should be such that a clown costume can be readily slipped on over it.

(58-9)

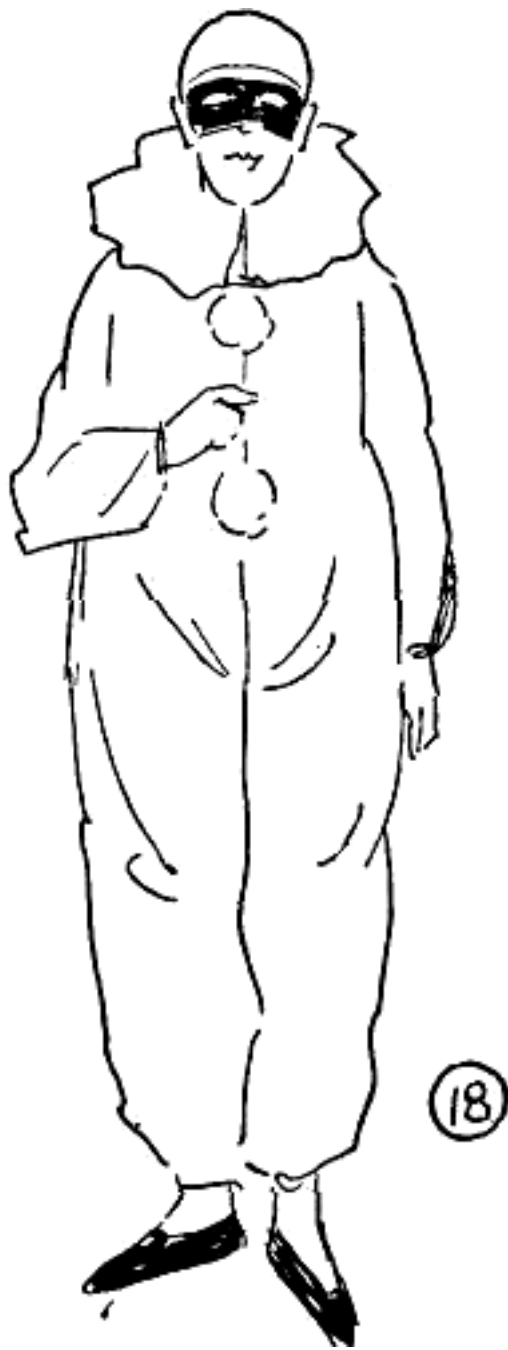




The Doctor - Something of an afternoon suit with the cutaway cut and striped trousers shows dignity of the physician. The Vandyke beard and mustache should be attached together and arranged so that beard can be easily slipped on and off at a moment's notice. With a physician's grip, the character is easily recognized.

The Clown - Fig. 18 shows the style of costume. It should open in front and be easy to slip in and out of. The usual clown skull cap is worn which in emergency could be made from a lady's white stocking. The upper end of stocking fits over head. The stocking is cut down and sewed together to fit head. A mask is worn over part of face as is shown in Fig. 18. There should be a pocket in costume large enough to tuck skull cap and mask into.

TWO OF THESE CLOWN OUTFITS ARE REQUIRED.



The Pirate - This is a typical pirate's costume. Fig. 19. The shirt and trousers are ragged and there is a sash around the waist. A handkerchief cap is worn. This should be fitted to head and sewed so that it can be quickly slipped on and off head. A black eye piece and mustache helps to complete the effect. The mustache can be the cheap kind that adheres to lips or can be fixed on wire so it can be held by being inserted in nostrils.

(58-10)





The Bartender - Ruffle up the hair and wear a large black mustache that can be easily attached. A shirt with sleeves rolled up and white apron gives the bartender appearance. Fig. 20.

NOTE: Shoes or slippers worn by clown, pirate and girl should be duplicates.

SETTING UP THE ILLUSION:

Place a clown outfit with costume, skull cap and mask, in compartment B in the platform of cabinet. Have costume on top and folded so it can be easily lifted up and put on.

In compartment C place the bartender's apron and mustache. Also the bottle and glasses, but have them at one side out of the way.

The top of compartment A is in place. The cloth is tucked down into the compartment out of the way and board laid on top.

Thus ready, the cabinet is placed on stage at left of center, and away from wings, etc. (Directions are given as you face audience from stage.) Doors are closed. Front door faces audience.

A few feet away at right the chair or stool is placed. The parlor screen is about ten feet at right of cabinet and back a bit.

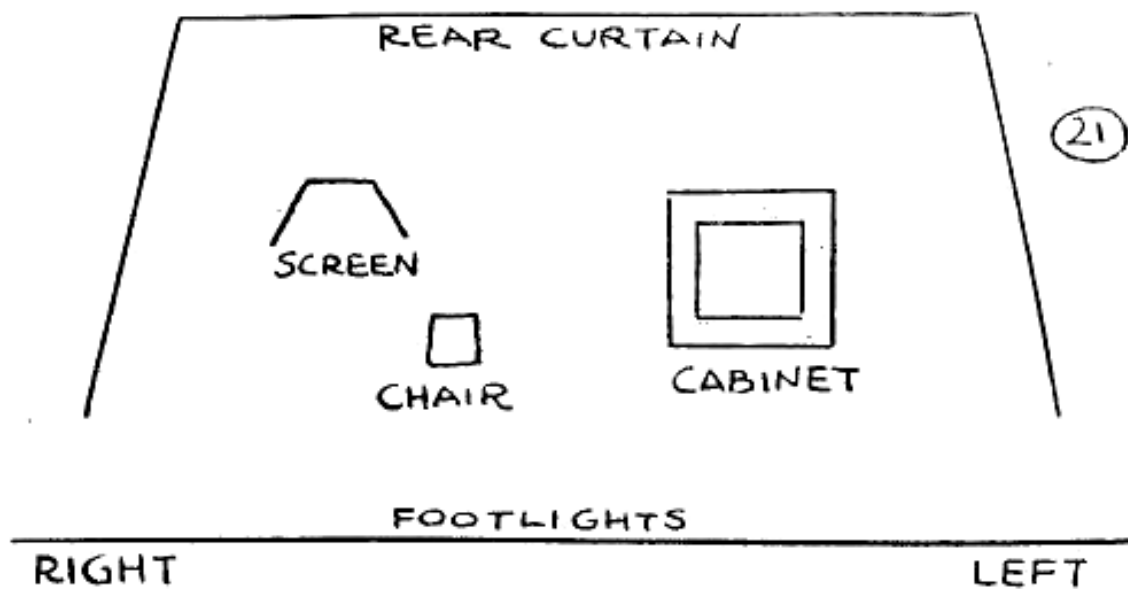
The policeman and doctor are off stage at right.

The clown wears a plain shirt with sleeves rolled up high and front of shirt opened part way down the front. This is to be used for bartender part. Over this slip the ragged pirate shirt also open part way down the front. Then the rest of the pirate costume with exception of eye piece, mustache and cap which should be tucked into pockets to be easily gotten at later on.

Over this, place the clown outfit. Thus we see that the clown becomes the pirate easily by slipping off costume and then adjusting things, and later is ready to play the part of the bartender.

The clown and circus girl stand inside the cabinet. The doors are closed.

Stage Setting, Fig. 21.



THE CURTAIN GOES UP AND THE ILLUSION STARTS.

TO PERFORM:

Policeman enters from the right side looking nonchalantly about and twirling his club. He looks about stage a few moments, then goes over and sits down on the chair and faces audience. He yawns and finally nods his head as though taking a nap.

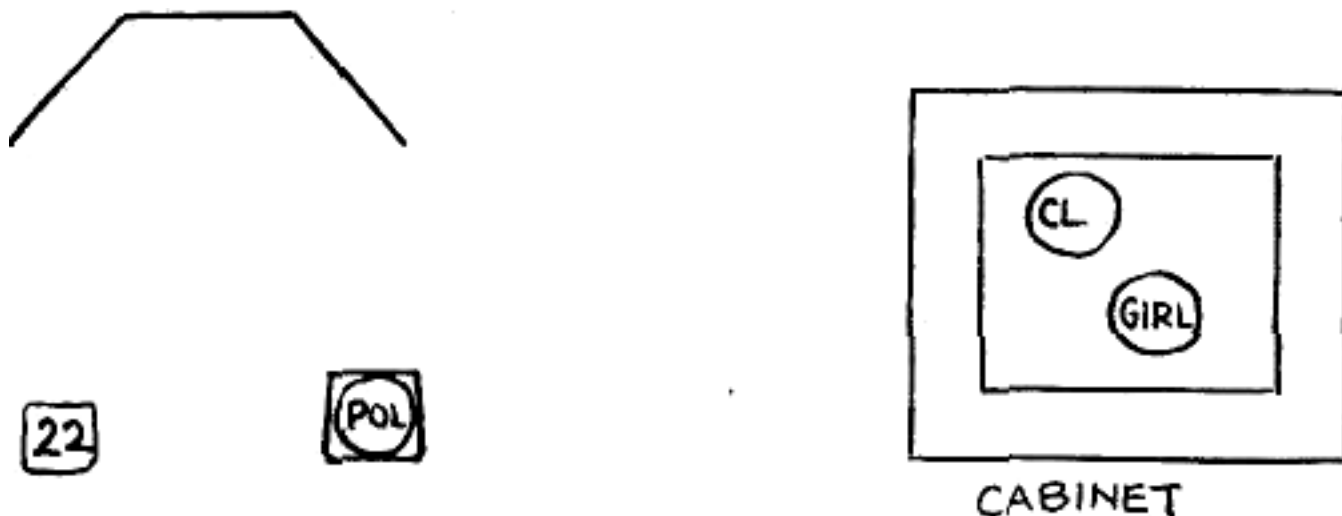


Fig. 22 shows position of characters at this stage.

After a few moments girl in cabinet gives a scream and cries for help, then all is quiet again. Clown steps to rear of cabinet and stands on the ledge closing rear doors again. The girl crouches down on floor of cabinet as though dead.

The policeman startled by the cry, jumps up and looks about and going over to the cabinet suddenly opens wide the front door showing the girl inside the cabinet.

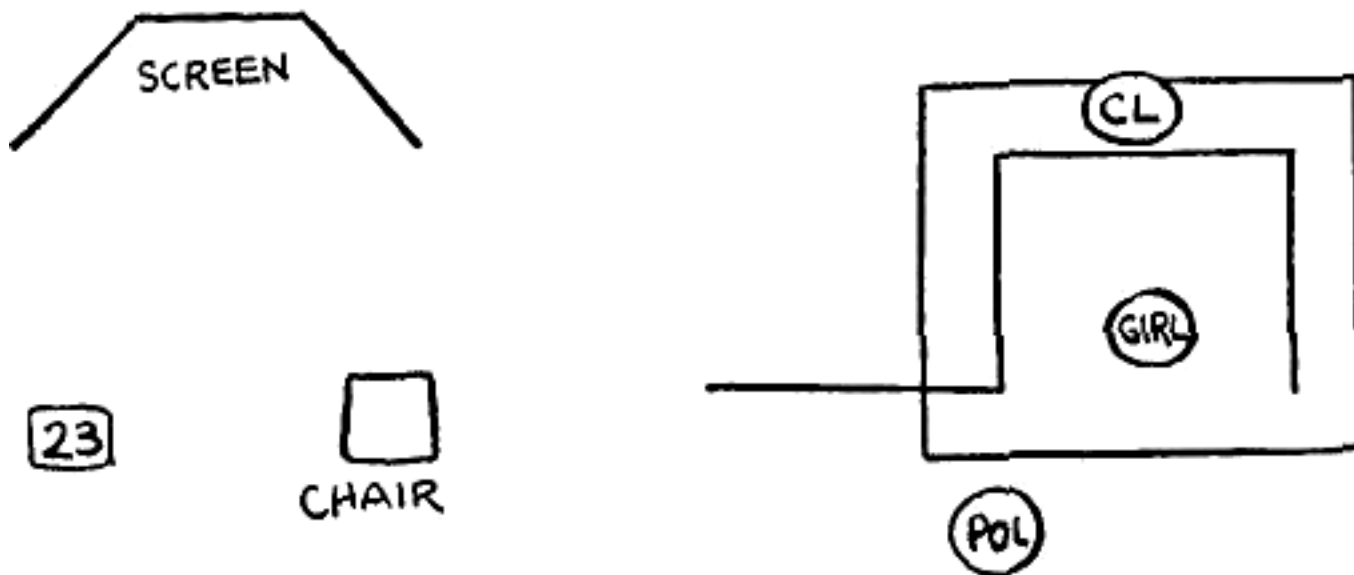


Fig. 23. He lifts her up, but she is apparently lifeless. When he releases his grip, she slumps down into heap again. He looks about for help, but finding none nearby, closes the cabinet door again.

The moment door is closed, girl gets up and goes to rear of cabinet with clown.

Doctor enters from the right. Policeman stops him and pantomimes the doctor that a girl has been killed in the cabinet. He may speak one word at finish for accent "Dead." Policeman and doctor go over to cabinet and policeman opens door wide, but the cabinet is empty.

At the moment door is open, the clown and girl step around cautiously on the platform to the right side of cabinet. The open door screens them from audience.

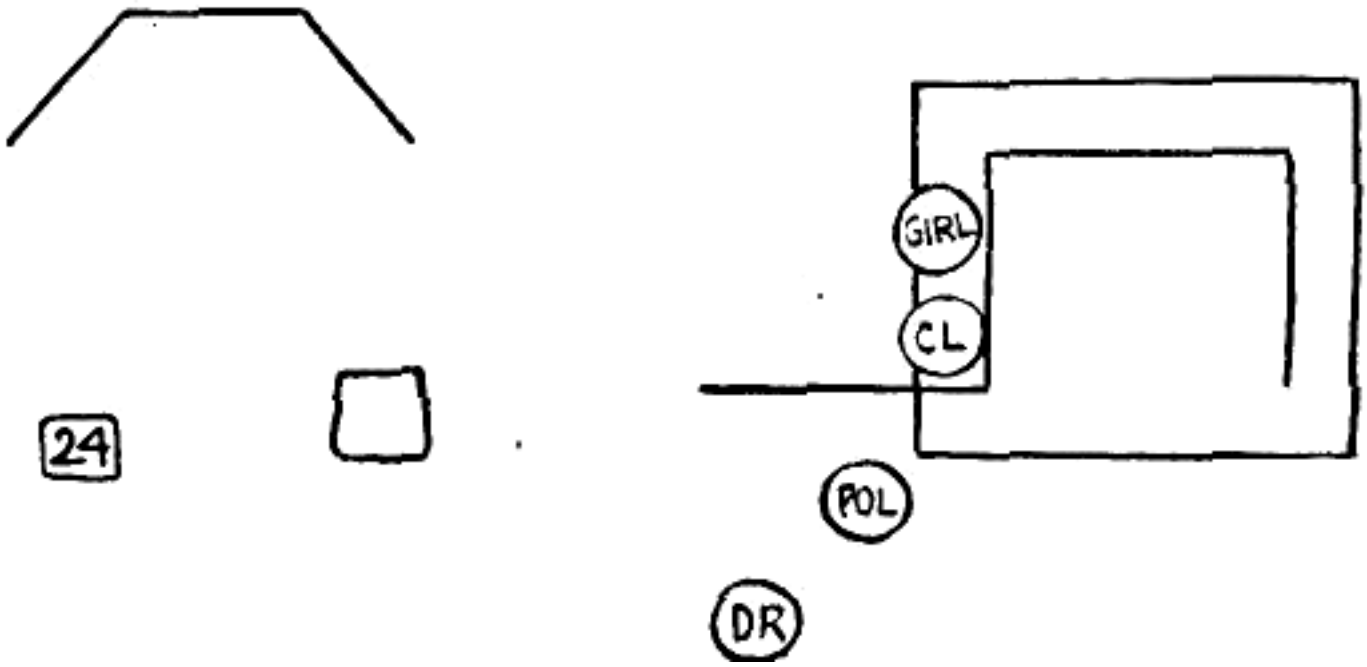


Fig. 24 shows positions at this stage.

Policeman is surprised and doctor does not know what to make of it. Policeman enters cabinet and opens the back doors. This lets audience look through the cabinet and see that no one else is concealed. Policeman examines inside of cabinet and closes rear doors again from the inside. He steps out of cabinet again.

When rear doors are closed, girl and clown edge their way back along platform to the rear of the cabinet.

Policeman steps out of cabinet and closes the front door and stands perplexed.

When door is closed, the clown steps inside the cabinet from the rear ledge of platform, closing door after him.

Not satisfied the policeman goes back to cabinet again and opens front door wide open suddenly. There stands the clown leaning against left wall of cabinet in a rather relaxed posture apparently smoking a cigarette. The clown takes things just as a matter of course.

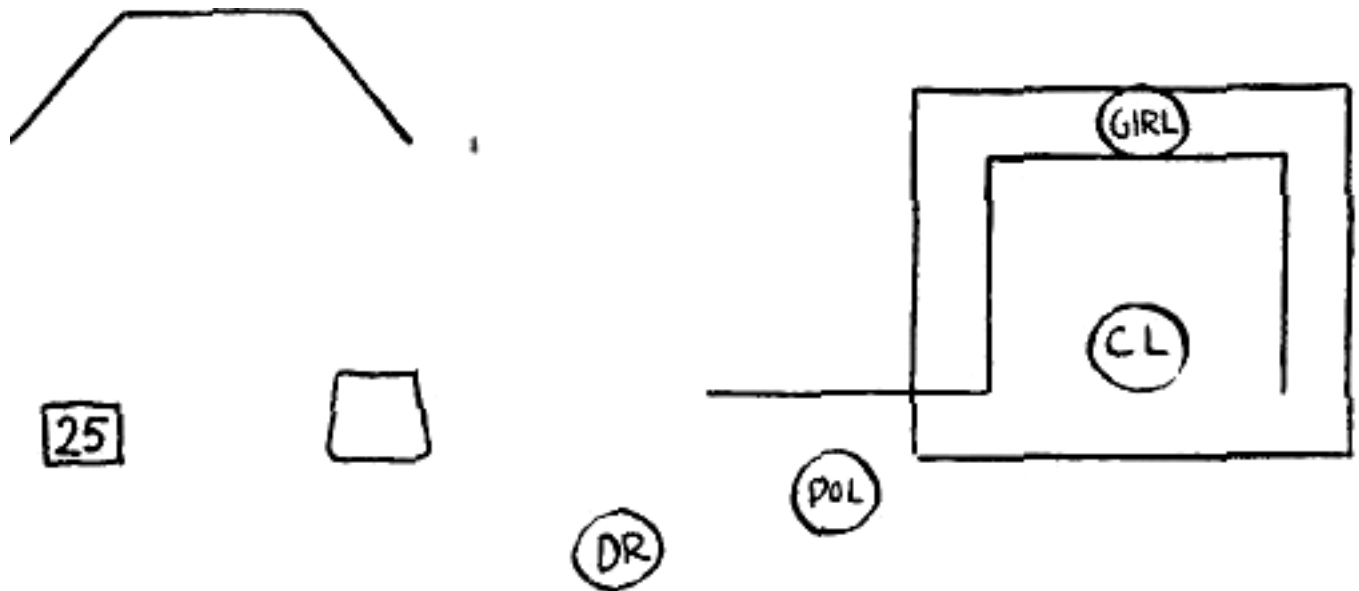


Fig. 25. Policeman motions him out of the cabinet. Clown and policeman go over on the right side of cabinet. As policeman is questioning clown in pantomime the doctor out of curiosity looks into cabinet, then steps inside and closes door after him. He gives a cry for help. He opens rear door and steps on rear platform with girl, closing door in front of him.

Policeman rushes over to the cabinet and opens the door. The doctor has vanished; the cabinet is empty. The clown gives a derisive laugh.

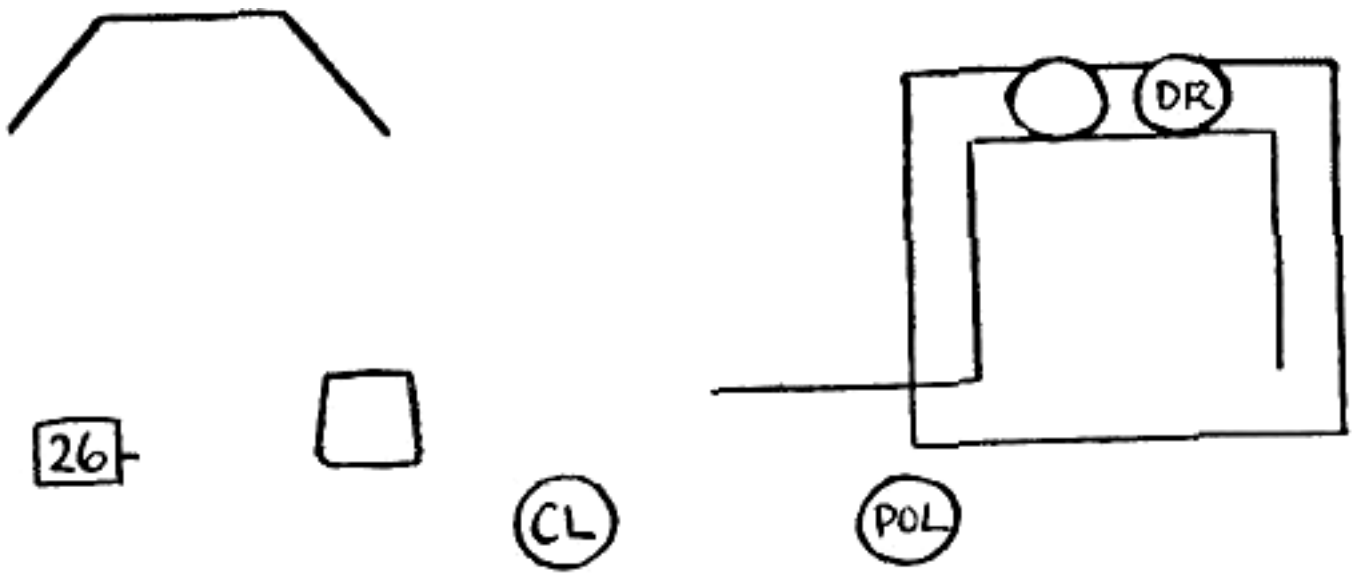
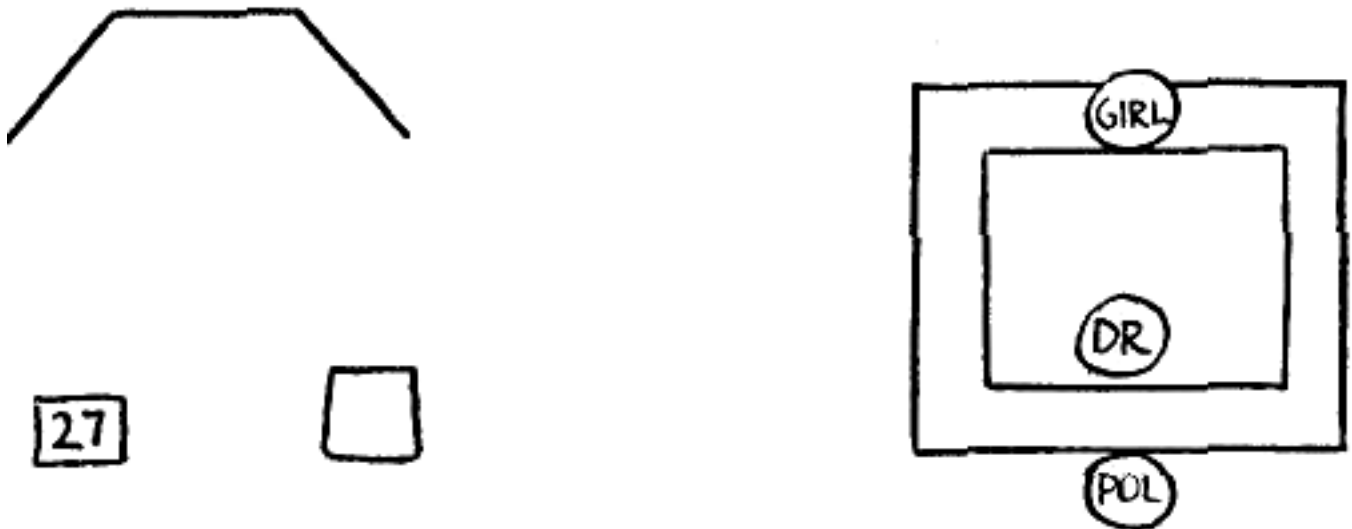


Fig. 26. Policeman, perplexed, brings doors shut again. He looks at side of cabinet, then stands directly in front with hand on chin, looking at clown, then at audience.



In the meantime the doctor has come inside the cabinet again and opening the small door in the front door opens it and reaching through takes the policeman's hat, lifts it from his head and pulls it through the opening into the cabinet. Fig. 27. He quickly closes the small door. Doctor hangs policeman's hat on hook on door at rear of cabinet and exits to rear through other door.

Policeman opens door and shows cabinet empty and hat hanging on a hook at rear. He replaces hat on head and then investigates cabinet again. He taps the left wall. He turns with his back to the audience. As he does so the clown quietly shuts the front door and closes the cabinet leaving the policeman in cabinet.

When door is closed, girl comes in and, opening side door, reaches her hand out and in again. Then in and out. Then out the small front opening. In the meanwhile the policeman takes his coat off and puts it on wrong side out and musses his hair. He drops hat on platform. This done the girl goes back to rear of platform.

Policeman starts to make noise and shout and shake cabinet and finally bursts out from front of cabinet by throwing door wide open.

Clown gives another peculiar laugh. Policeman draws pistol from pocket suddenly and points it at the clown. With clown under pistol he closes cabinet door.

The moment door is closed, the girl enters the cabinet and lifting up door of compartment B, takes out the clown uniform and gets into it. She should imitate clown as near as possible. When dressed, she shuts door to secret compartment again.

In the meantime the policeman has pantomimed the clown over to the parlor screen and has him turn it around and place it around him. This should be done to show audience no one else is concealed.

The clown stands back of screen, the policeman has pistol pointed at him, and girl in cabinet is dressing. The doctor stands patiently on rear of cabinet.

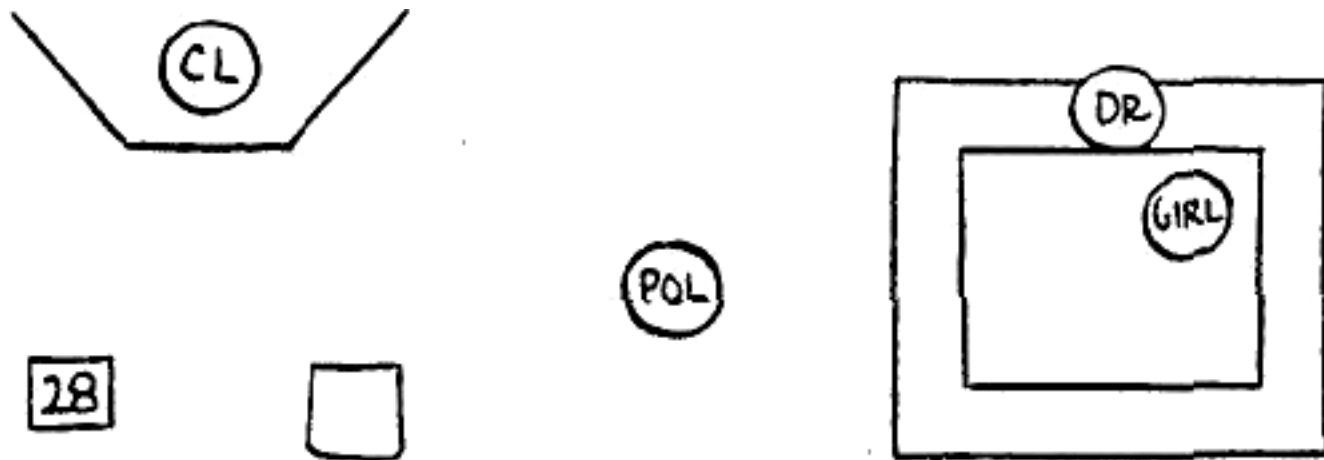
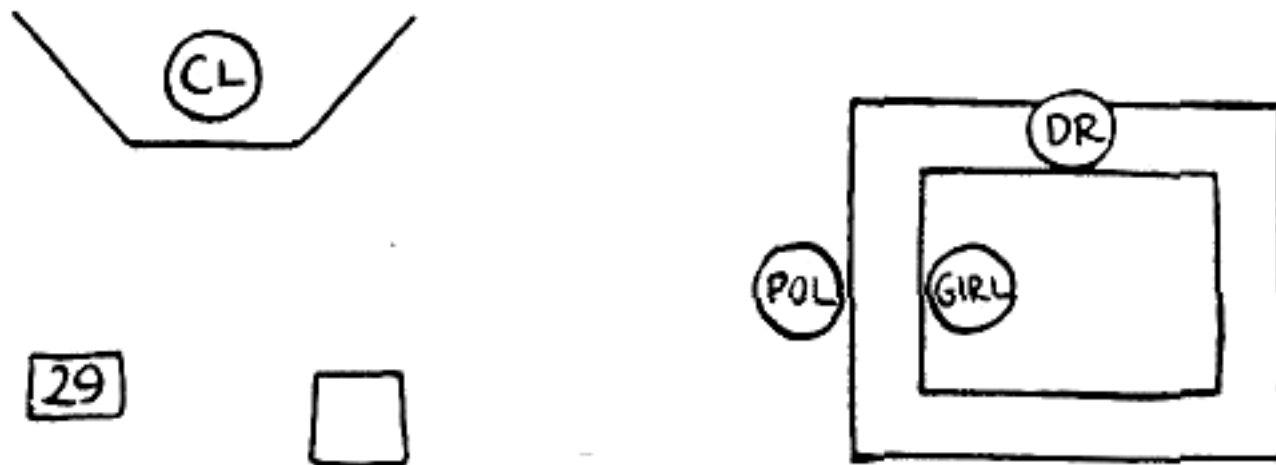


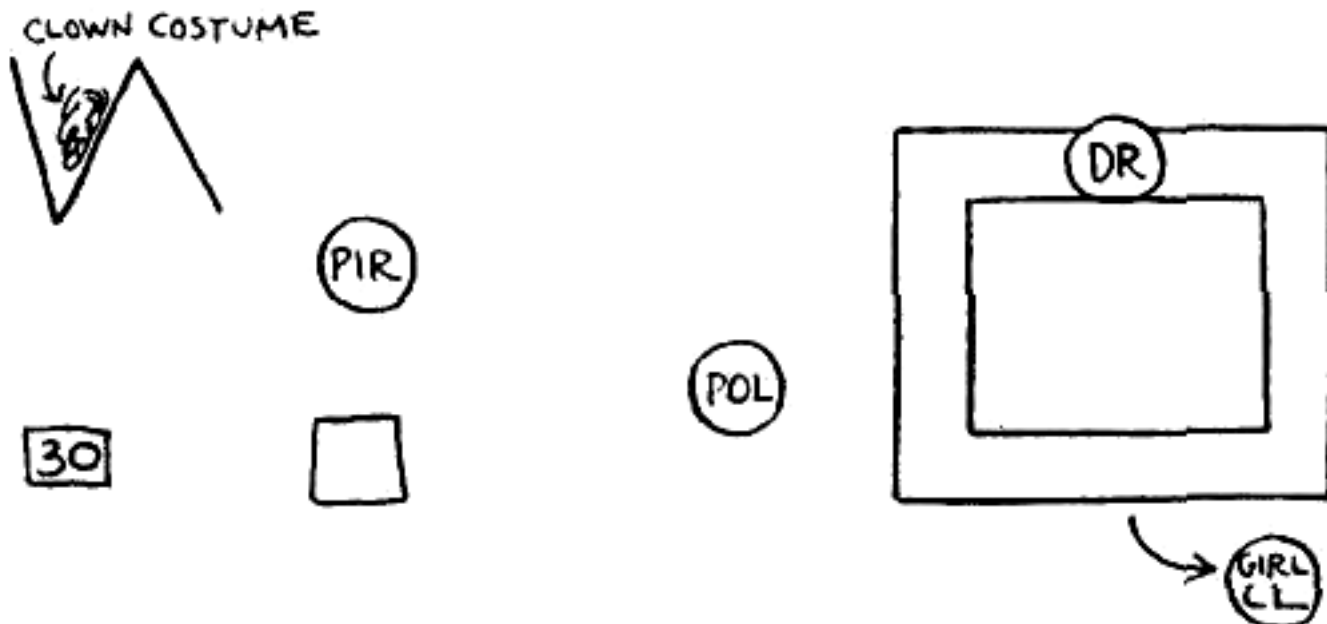
Fig. 28. Screened by parlor screen the clown quickly slips out of his clown outfit, first putting his skull cap and mask in pocket and then hanging costume on hook at rear of middle panel of screen. Clown changes as quickly as possible to the pirate costume.

Policeman steps back to right side of cabinet with his back against the wall.



Clown shakes screen a bit. Policeman raises his right hand with pistol. The door in side of cabinet opens and girl reaches her hand through and flicks pistols from his hand. Fig. 29. Then closes small door again. Policeman looks at hand perplexed after he has suddenly swung around and looked at cabinet. He then reverses his coat and tries to look normal again.

From behind the screen the pirate sticks his head out, then closes up screen a bit and moves it a foot or two to right. He takes care not to expose clown costume.



He has a pistol in his hand and points it at policeman. Policeman turns and finds himself under pistol cover of pirate. Policeman raises his hands above his head. As this is going on the girl dressed as clown opens quietly the front door of

cabinet, steps out, closes door and exits from stage at left side. Fig. 30. The position that girl stands in while door is opening is similar to that taken by other clown when policeman found him in the cabinet.

(58-15)

The actions of the two clowns should be as nearly alike as possible so audience thinks that the clown who was a moment ago behind the screen suddenly appeared from the cabinet again. This adds to the sense of mystery.

The pirate forces policeman in front of cabinet and then far enough to left of cabinet so he, the pirate, can open door, and then beckons to policeman to enter cabinet, which policeman does. He gets in cabinet after policeman and closes door. The doctor comes into the cabinet as the policeman and pirate step to rear.

The doctor takes from his pocket the dagger with card on it and opening small door in front of cabinet sticks his right hand through it with the dagger and throws dagger down to floor, trying of course to cause it to stick in floor and stand straight up. He closes small door again.

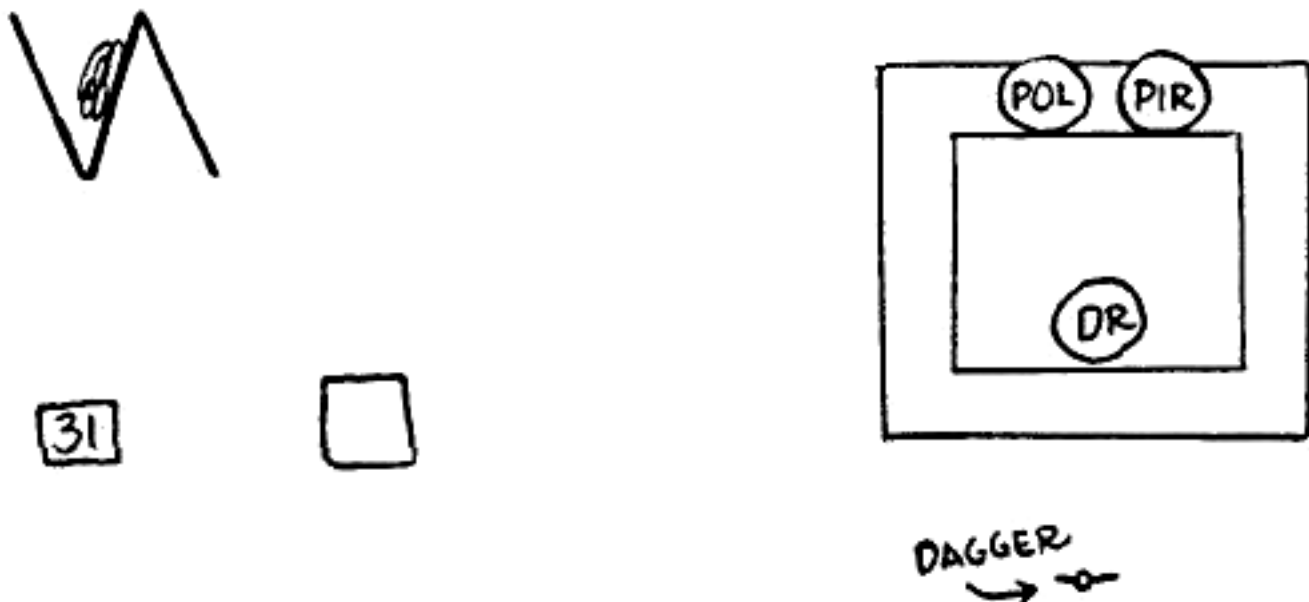


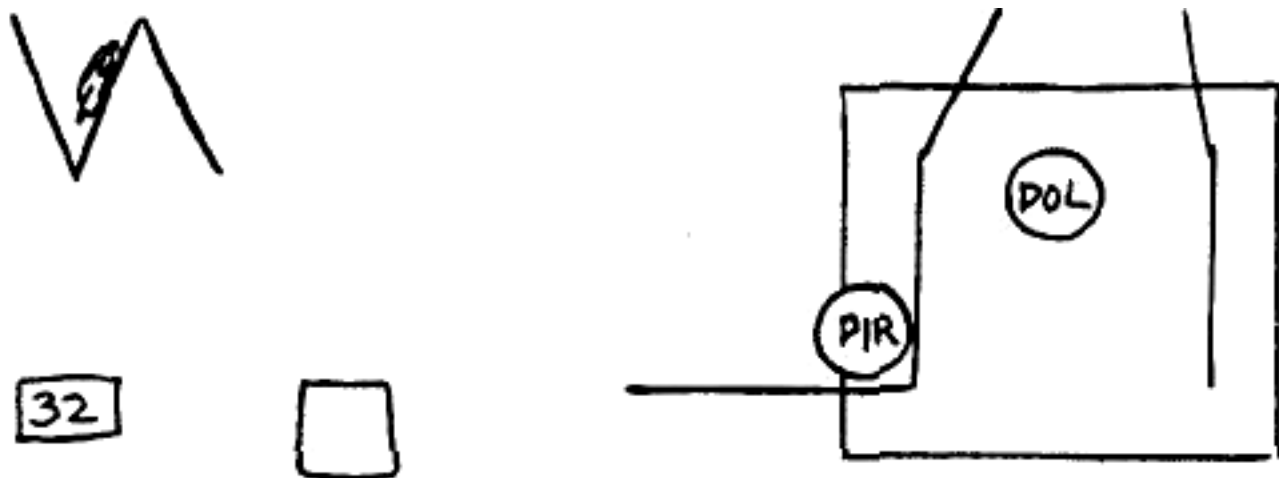
Fig. 31. He opens front door and steps out. Then closes door again. He looks about and picks up his medicine case, then seeing the dagger picks it up and reads note. He exits at left, shaking his head and looking at card.

Now, in summing matters up a bit, we find the girl assistant and the performer off stage at left. Each adjusts himself, the performer removes hat and beard and puts professional grip aside.

Then they go over to right side of stage behind the scenes and wait for their time to come on again.

In the meantime when doctor has closed door of cabinet before his exit, the policeman comes into cabinet. When doctor has gone off stage, he waits a moment and opens the door, scratches his head. The situation is apparently too much for him to understand.

When door is opened, the pirate moves around ledge of platform to the right side of cabinet where door conceals him from spectator's view.



Policeman turns and suddenly opens rear door at right, then suddenly opens left door in a dramatic way. Fig. 32. Then he closes the doors and steps out of the front of cabinet.

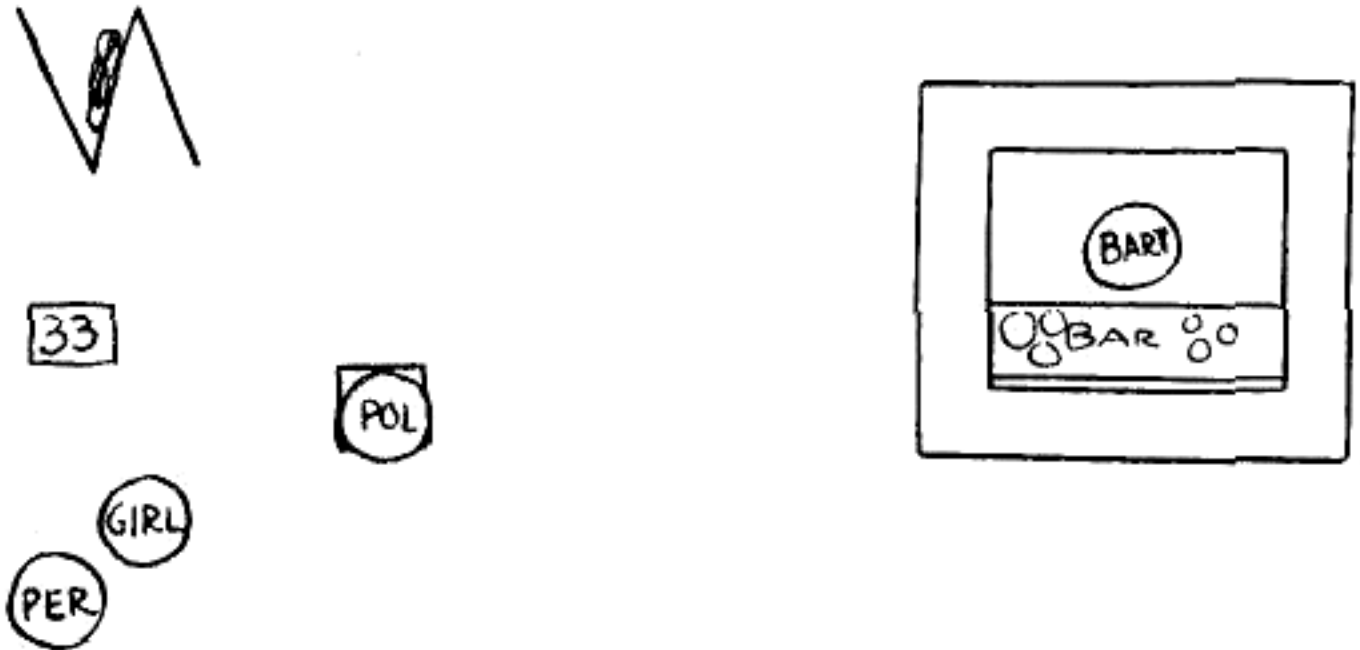
When rear doors are closed, the pirate moves back to rear of cabinet. Policeman closes front door, and still looks about perplexed.

The moment front door is closed, the pirate enters cabinet and raises door of compartment C in platform. He removes handkerchief cap and musses hair a bit. He removes mustache and eye piece and drops same on floor. He removes his pirate shirt and drops it also on floor. Then dons the apron and puts large mustache in place. He reaches over and picks up board covering compartment A and lifts it up bringing it up in a vertical position in front of the staples in sides of cabinet and finally lays board on the staples to form the bar. Fig. 13.

He reaches down and picks up bottles and glasses and places on the bar. If he has a beer sign handy, hang it at rear of cabinet.

All is ready now for the finish.

To allow time for this, policeman looks about perplexed and then finally gives up and sits down on the chair again. Soon he yawns, his head nods and he goes to sleep.



The performer and girl now come in gaily laughing and talking. Fig. 33.

The policeman wakes up and looks at them. He gets up and continues looking, finally he gets up and goes to girl and takes her arm.

Policeman says, "I thought you were dead."

She replies, "Dead? What are you talking about?"

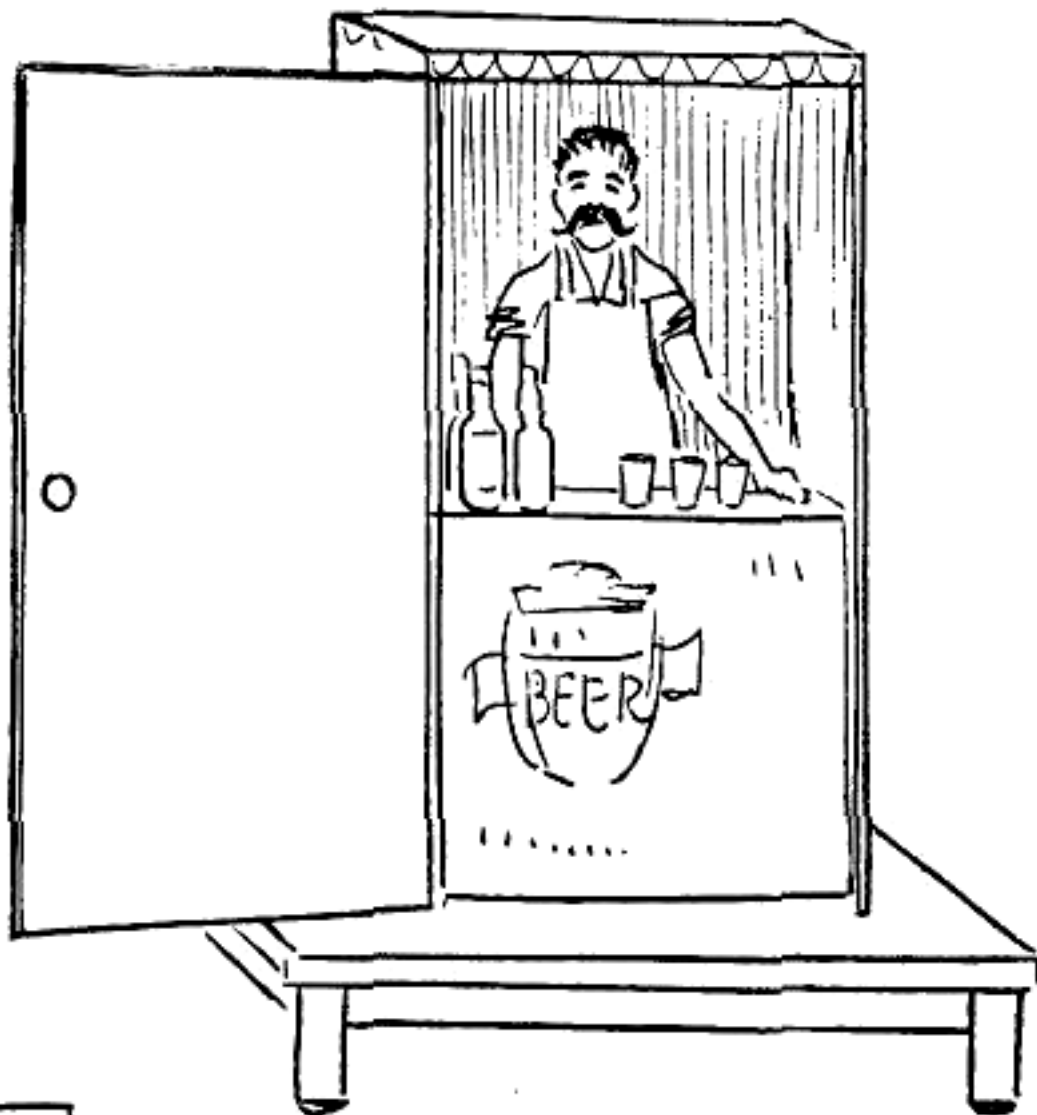
Policeman: "Only a few moments ago, I came in here and I heard a scream come from the cabinet there and when I opened the door you were inside it, dead. Then I went out and got a doctor and you had vanished, and a clown came out of the air and I arrested him, then the doctor disappeared and a pirate came, and I lost my revolver, and he disappeared and finally I had to lick eighteen robbers and - -"

Performer: "Wait a minute! Wait a minute! Either you are intoxicated or have been dreaming."

Policeman: "No sir. It all happened inside of that cabinet. I think there's spooks in it."

Performer: "Nonsense. There is nothing the matter with the cabinet. That is just my private - -"

He opens door and shows inside of cabinet with bartender standing behind the bar and ready for service. Performer: "Bar."



34

Bartender says: "Well, gents, what'll it be?"

CURTAIN GOES DOWN.

The finish comes so unexpectedly and is of such a comedy nature that it gives a WALLOP to the finish of the illusion.

For encore, have curtain raised again. Bartender is serving drinks, and policeman, girl and performer raise their glasses.

* * * * *

And thus has been described to you "The Phantom of the Circus." Study it carefully, work up its dramatic moments and properly handled it can keep an audience on edge until the finish. There is a chance for many possibilities while door is closed and the small doors are of service.

Many weird effects could be operated by the hands through the openings using various articles.

Mystery and drama have held their place on the stage, and it has its place in magic. An illusion can be made about as thrilling, chilling and mystifying as a performer cares to make it, by surrounding it with the proper plot.

There is such a great field for the drama in illusion work that it opens a royal opportunity for many who have the showmanship and dramatic sense to appreciate it.

* * * * *

LESSON 59

Publicity Principles you will require in Selling your Show. Making the Box Office pay.

MAKING THE BOX OFFICE PAY

The preceding lessons have laid great stress on teaching you how to perform various magical effects. This lesson will take up the commercial side of magic and deal with those things which will enable you to sell your wares and be amply repaid for your services.

As to what this pay will be, depends a great deal on you yourself, and the end toward which you work.

For example, one man will want to make money; another does not care so much for the money angle but is interested in the social prominence it gives him. Another will want to become a center of attraction and make himself interesting to others, rather than sit in the corner of obscurity. Some students take up magic for its educational value and for the insight that it gives them into life's variety of illusions. Many a person has told me that since studying magic, life has taken on a broader, bigger and nobler outlook. Also that they had been taught to look behind the scenes and not take everything for granted, but to study the cause behind an effect. Still another man wants magic to help in expressing himself, to be able to sell his personality better and to stand squarely on his feet and talk with clarity, interest and confidence. Among my students I have ministers of the gospel, who, through effects in magic, hope to better illustrate the teachings of the Bible and better bring the wonders of God to their listeners. As a result, many beautiful stories have been evolved around a magical effect that will long be remembered. Again, there are educators who seek in magic the solution to problems of science, art and society. Men, too, study magic and educate their children with it, so as to protect themselves against confidence workers and fakers who are ever preying upon the public. Knowledge of magic and high pressure methods of those who seek to blind truth with illusion would have saved many a dollar.

Never let discouragement get hold of you. Just keep going. There will be plenty of relatives, friends and well-meaning people who will try to discourage you and perhaps tell you that you have no ability. Do not believe them. Let them go over by the fence and lie down in their feeling of inferiority if they want to, but you stand up on both feet and look the world in the face and feel just as big and great as any living man.

In every man is an individuality not possessed by anyone else and it is that individuality properly given to the world that will give man his success. Too many people bury their individualities because they are afraid to be different.

You do not have to be Herrmann, Kellar, Houdini or Thurston to be a success at magic. Neither do you have to imitate them. Each of them built his success on his own individuality and by not imitating the other.

Thurston told me that when he bought the Kellar show and Kellar bestowed his mantle on him, that there were only two effects that he could use from the show. One was the levitation and the other was the spirit cabinet.

Many a man would have tried to imitate Kellar and given the same program that Kellar did himself. It is difficult to walk in another man's shoes. Why try it, anyway, when you have your own shoes to walk in? Thurston never tried to be a Kellar. He did, though, work day and night to be a good Thurston.

In arranging your program I want you to do those things that you like best to do and that you can put your whole heart and soul into doing. Do not worry about what the other fellow is doing. You do what you are best capable of doing. Do the things you can get best dramatic action with and can create the most interest. Nor is it the biggest thing or most expensive thing that creates the most interest. I have seen the vanishing cigarette in the handkerchief taught you in your second lesson get a bigger hand and create greater excitement than a five hundred dollar illusion requiring a number of assistants.

It isn't always what you do, as much as it is how you do it. One cook can take ingredients such as eggs, flour, milk and sugar and make a truly wonderful cake. Another with the same ingredients and recipe will make a soggy mess of it. It is the same way with magic. What may be a piece of artistry in one's hands may be just a feeble trick in another's.

There is that soulful influence so necessary in an effect, that life-giving element that makes it live. Success is so dependent on that life-giving interest and through it you can make your box office pay and make a name for yourself. YOUR SUCCESS DEPENDS ON BEING DARING AND DIFFERENT. IF YOU WILL GIVE THE WORLD YOUR OWN BETTER SELF, YOUR INDIVIDUALITY, YOU WILL BE SUCCESSFUL.

When we speak of making the box office pay, the question arises "What do you want your box office to pay?" You want WEALTH of some kind. You can have the WEALTH you decide upon if you will bend your attention to it and work with understanding and common sense. Big things are the result of careful growth. You must start with the seed and with proper care develop gradually into the flowering process and its fruit. Day by day we seek means of progress, of eliminating mistakes and short cuts to our ends. You, like every man, have your individual problems and it is up to you to use your brain power and by proper care bring about the bigger things you desire.

Some time ago I was talking to Gus Fowler, the eminent English magician, so well known for watch and clock magic. He was telling me how he got started in magic. "I realized," he said, "that there were many better manipulative magicians than myself and if I were to make good it would be better to get away as far from competition as possible and away from the usual run of things. So I worked out an act in which I specialized in watches and clocks. I would utilize the old

principles of magic but would combine them differently and present them in a different way, which would be new as far as the audience was concerned. My act caught on quickly, it was easy to sell and as you know I have been kept busy in vaudeville at a good salary. I succeeded because of my individuality and the same thing applies to other men entering the magic field, - they must educate themselves well in the principles of magic then adapt them into something different."

Magic is so full of opportunities. There are so many places that one can go to for material. In no profession in the world, perhaps, can a person take such liberties.

My students, by applying the training I am giving them, can become big magicians and be financially prosperous.

Those students who are alive, energetic, hungry for knowledge, seeking to progress, are appreciative, not afraid to work and assume responsibilities, and who will listen to experience, will some day cause a great commotion in the art and science of magic.

They know that the instruction they are getting in this course is right and they are applying it. And they are coming to the front.

I received a letter from a student not yet through his course. He said he had just played three dates for which he received \$97.50. Ninety-seven fifty for six hours work!

A splendid example of what you can do if you will it! -is the experience of Cardini. He was not always the successful magician he is today. If anybody had to buck hardships, he did. Shell-shocked after the World War, he lay in a hospital bed in England, helpless. A magician who played in his ward stimulated his desire to learn magic. He dug up what few books he could on the subject and, getting a few decks of cards, practised sleights by the hour. When nurses and doctors saw him going through the various movements they thought he had gone crazy and put him in the psychopathic ward. Later on, as the effects of the shell shock wore off, he began giving entertainments. Finally he wandered into Gamages in London and sold magic tricks and novelties from behind the counter. Then off to Australia where he put his knowledge of magic into practical use and became a vaudeville success there. So on to America. But here things did not go so good. For five months he suffered hardships trying to get booked. Then it was that Percy Abbott and I became intimately acquainted with him. To Cardini the situation was serious. He wanted to go back to Australia as soon as possible. Abbott gave him the various tricks of the American stage that he had picked up in comparison with the English and Australian. Abbott had played theatres the world over and knew commercial angles. Then I went into things for Cardini from the standpoint of a magic coach, and advised him to go to the very heart of things, New York. As most magicians know, Cardini was soon in vaudeville with a novelty act that was the "talk of the town" wherever he

played. Two years later he was married, and now has a son Richard, Jr. and is driving a big car and living in a manner becoming a gentleman.

Houdini, a poor boy, fought his way to the top, and made a reputation, never surpassed by another in his particular branch of magic. He was heavily criticized from every angle, but he built a reputation with the show-going public. Houdini learned the law of commercializing a particular ability. He realized many of his weaknesses (everybody has them, you know) but he accented his strong talent and ability and became famous.

I do not think that Thurston was born with a gold spoon in his mouth or was carried around on a silken pillow either. Yet Thurston has built for himself a reputation. He has had plenty of criticism. But, while others were criticising, he was working on his show and impressing the public that Thurston was a great magician.

THERE IS ONE THING THAT I WANT TO IMPRESS ON YOU RIGHT HERE, AND THAT IS: THE MORE SUCCESSFUL YOU BECOME, THE MORE YOU WILL BE CRITICIZED AND OPPOSED.

I often think of my good friend Dr. George Rockwell of Quack I Quack! Rockwell has rocked audiences with laughter time and time again. He is one of the greatest comedians in America. As I write this, he is the leading comedian of the Greenwich Village Follies, with a salary of more than \$2000 per week. Before he joined the Follies he was a headliner on the Keith-Orpheum circuit. To have Dr. Rockwell billed meant to have a good sized audience to greet him.

He made a large salary because he had something the public wanted and were willing to pay to see. A theatre was farther ahead by paying him a thousand dollars than they might be with someone else at fifty dollars. He made the box office pay in such a way that a manager could afford to pay him big money.

Now Rockwell did not start in the business as a headliner. He started about three cellars lower than the basement. Rockwell was interested in magic and it wasn't long before the public gazed on Rockwell as a magician, at least he said he was billed as a magician. But in presenting his "startling mysteries", something usually went wrong, the thread broke or something tipped over or some piece of apparatus stuck. So in explaining to the audience in true Rockwell style what he had intended to accomplish, he was surprised to find that the audience was more interested in his explanations than they were in his magic. He discovered that a performance that went smooth and in perfect working order was a frost in comparison to one that went wrong and demanded his specially-treated explanations.

Then he awoke to his individuality and that was that people were interested in his brain twists and his peculiar ability to explain a serious subject in a comedy way. But it took him years to really find himself and to have this tremendous truth driven home to him.

Then he became interested in health and health-building and in his experience with many branches of healing saw an angle by which he could go before the public and explain health-building from his own peculiar angle. So he sold his individuality. And he shot to the top as a headliner. Audiences wanted to hear the good-natured Doctor explain their troubles away.

Rockwell's observation in health-building amongst the various creeds and cults and a study of the patients and Doctors gave him a great slant on what the public as a whole wanted and were willing to pay for. As a reformer he could lose, but as a health comedian apparently serious in his health-building advice, he would be successful. He discovered the psychology of his audience and went accordingly. To begin with, he discovered that he first had to gain a bond of understanding with his audiences and meet them on their plane first. Down in the heart of most everyone there is a desire to do something off the strict laws that Nature demands for perfect health. People like to smoke, drink a bit, overeat, over-indulge, etc. So, in coming on dressed as a successful physician he broke the tension by having a large overgrown cigar in his mouth and gave people that after-dinner feeling of "Now, we'll all relax and sit around for a food chat and a good time."

The true strength of the importance of that cigar was brought to my mind in New York City last summer at the Winter Garden Theatre where he was headlining in the Greenwich Village Follies. He swung the show until the time for the Finale when the actors stand in line before the curtain and join in the Finale until the curtain goes down. As he stood there, he was just one among many, his individuality was gone, and he was a weak spot.

It hit me hard, to see him hold his audience so well to the last moment and then weaken at the finish. I made double quick time back to his dressing room. "George, what on earth is the matter with the end of the show, you wilt like a faded flower."

"I know it," he said, "but I can't find the kick that is required. I do not dare stand out too strong by hokum business because of the rest of the cast. And somehow I feel out of place there or something. But the management wants us all on the stage for the final curtain."

Then I started to analyze the show and his act. What was it that held him in the beginning and at the various height spots? Then I thought of the cigar that he used to open his health talk, and the lighting of the cigar in his famous discussion from one of the upper boxes to gain attention and let the audience know he was amongst them. The moment he struck a light and lighted the cigar the audience snickered and settled down in comfort to know that he was there.

"George, it's the cigar. I've got it now. You haven't your cigar at the finish."

"You've hit it," he said. "There's a million dollar suggestion. Sure, the cigar established a means to let off a certain energy and establish a good natured he-man connection with the audience. You know I felt like a sissy standing there at the end of the act without that cigar. From now on, in goes the cigar."

I tell this incident because I want you to see that the big men of the stage are humans like anyone else, but they are quick to grasp opportunities and are always on the lookout to better themselves. They discover their particular individualities and commercialize them. They want to be distinctly themselves and not a copy of someone else.

Let us learn from those who go over the top and whom audiences pay to see.

THE CHANGING WORLD

The world changes and the change is not limited to any special department, but to the whole. That which might be the rage one year is discarded the next. Many times when a new style appears, it is laughed at, yet when it has gone far enough to be a part of custom or to impress itself from the proper angle, it becomes the rage and the manufacturers are kept busy day and night keeping up with the demand.

The show business is no different than styles of clothes as far as changes are concerned. The plays of the gay nineties that pleased our fathers may be laughed at today. It is true, however, that certain masterpieces live throughout many ages as they are based on such a universal theme and are based on such fundamental emotions that are a part of each age.

The basic principles of magic will never get old. They will always be interesting. However, the style of presentation will vary and must be modified and presented according to popular environment. At the present time we are living in an age of speed, of stimulation and high pressure, and it requires something of a similar nature to create an impression. As to the degree that this is essential, this depends on the locality. People in the cities demand greater action than country people. A performance that may go over with a wallop in a small town might put an audience to sleep in the city, and the speed of the vaudeville stage of the city may be a bit too fast for the smaller town.

This all may change in time however, especially since so many live programs are heard over the radio. City entertainment is now brought closer to the farm and the entertainment of the larger cities is becoming more and more familiar to persons in small towns.

YOUR PLACE IN MAGIC

Magic has a number of branches. You have perhaps already found one of the branches you like better than the rest, and will specialize along these lines. Or you may find a combination that appeals to you. It pays to experiment carefully and see from which angle an audience best welcomes you and into which your personality fits best.

Many times we have the law of reversed action and we find people particularly liking a special branch when they are not adapted to it. They may have seen another person successfully play the part and imagine themselves to have the same personality. Sometimes when we are weak in a particular line, we crave it, and hope and struggle that we may strengthen ourselves there. That is a way Nature has of balancing things, but from a commercial angle it is best to give the strongest angle of a person to the public. It is all right to express ourselves in our weaker departments for the standpoint of development and education but not to mistake them for our base when they are really our inclinations.

Each of us has

1-A base

2-A first inclination

3-A second inclination

The base is our solid foundation, the inclination our next well-developed mental equipment, and the second inclination the weakest. We see so many misfits in life because they are not working on their base but on inclinations. They may be inclinations induced by others. Perhaps mother regrets that she did not marry a doctor and she insists that her son be a doctor because she likes the profession herself. Now the son may be basically a musician and not adapted to a physician's life. But to please his mother he takes it up. The result is that what might have been a good musician becomes a poor physician.

Some time ago a mother came into my studio with her son. She was wrought up over the fact that her son wanted to be a magician.

"I want you to convince my son that he is not be a magician," she said. "There are two things that I never wanted my sons to be, -one is a farmer and the other is a magician. Now my other boy has turned out to be a farmer, and this boy says he is going to be a magician."

"Well," I replied after having given the boy an analysis, "To tell your son not to be a magician is just like telling a fish not to be a fish, or a horse not to be a horse."

There was a boy who was a magician from the top of his head to the tips of his toes. He had the personality, the basic skill and the muscular grace of a fine artist. He had something to develop. If he did not follow the stage, he should at least place himself vocationally so that his peculiar talent would have a chance to exert itself. Reverse Action.

Occasionally we see a person starting out on the stage with the intention of being very dramatic and working to the art of the tragedian with the result that the audience gets a reverse angle and takes it as farce comedy. Tragedy and the dramatic are so far away from the real personality that the audience sees that the ridiculous side arises.

There has been more than one comedian who convulses his audience that did not start in comedy but had dreams of doing great love scenes and stirring dramatics and comedy was forced on him by the reaction of the audience to his seriousness.

And in a similar manner people who craved to be comedians turned out to be tragedians or something apart from comedy.

In magic you will find professionals many of whom have not found their true field of magic and who would be many more times successful, financially and otherwise, if they had.

Little by little I hope to get magicians into their proper spheres of the profession so that they, as well as their audiences, may profit accordingly.

The Branches of Magic.

Let us divide magic into its various branches from a general standpoint. We find the following fields:

1-Sleight-of-hand, or Manipulative, magic, involving the smaller articles such as coins, cards, billiard balls, etc.

2-Mechanical magic, dependent greatly on specially constructed apparatus.

3-Illusions, dealing with the appearance of large objects.

4-Dramatic, which consists of magic woven into a carefully woven dramatic play or action.

5-Pantomime magic.

6-Monologue or Patter magic, in which magic is incidental to a monologue or special patter.

7-Comedy magic.

8-Costume magic, of the quick change variety.

9-Electrical magic.

10-Chemical magic.

11-Scientific magic.

12-Religious magic.

13-Flash magic, which consists of a flash of color and action and is of the spectacular.

14-Spectacular magic of a sensational type.

15-Escapes.

- 16-Educational magic.
- 17-Mental magic, such as mind reading.
- 18-Spiritualistic magic.
- 19-Black Art.
- 20-Speciality magic, dealing with some special articles such as clocks, as performed by Gus Fowler.
- 21-National magic, being based on a special country or location, which includes Hindu, Chinese, Japanese, Spanish, French magic, etc.
- 22-Animal magic.
- 23-Burlesque magic.
- 24-Sales magic.
- 25-Pocket and impromptu magic.
- 26-Publicity magic.

We could add to the list and then subdivide and combine into many combinations. Just think of the many fields that offer success to the magician. You have plenty of room to work. You as a beginner have just as much opportunity for success as an old-timer in the business. The big idea is, are you willing to keep your eyes open and apply yourself in a common sense manner?

Taking up the departments of magic from another angle, we find the following fields for selling one's services:

- 1-Club Entertaining.
- 2-Society Entertainments.
- 3-Children's parties.
- 4-Schools, colleges and organizations.
- 5-Lyceum and Chautauqua.
- 6-The Concert Field.
- 7-Hotel Entertaining.
- 8-Carnivals and Side Shows.
- 9-Tent Shows.
- 10-Motion Pictures Houses.
- 11-Theaters.

12-Vaudeville.

13-Specialties for Revues.

14-The educational and religious field from an instructive standpoint in which magic is used to illustrate dominant subjects.

15-The selling field, and the promotional field.

16-Summer and Winter resorts.

DIRECTING YOUR SHOW

Success in business is not built on just one thing but the accumulated growth of many things. For this reason not only do the generalities have to be attended to, but also the details.

Many men have shot forward to success above their competitors because of their infinite care of details. Of course men too have failed because they were lost in a maze of details and lacked the big generalization of a business.

The big idea is that you must render better service, have a better product and produce better satisfaction than anyone else to be a leader.

To make your show, the show that is talked about, you must watch its every angle and see that it is as near perfect as possible. It must not only possess certain big essentials but to have that finish which shows the work of an expert.

Most foreign acts that come to America are particular about the amount of finished details that they place in their acts. Many of the acts succeed on the infinite pains given to certain details that other acts would overlook.

The trouble with some magicians today is that they labor and concentrate on some do-dingle sleights and live in obscurity, when they could devote the same effort in the right channels on something that would interest the public thus making them wealthy.

The magic business is no different from any other business. All businesses are based on business principles or they would not belong to that classification.

A successful magic show should cover each of its departments as efficiently as Sears Roebuck & Company or Montgomery Ward do.

A good show must have an executive-someone who can make decisions and whose judgment can be relied upon. And it needs a creator-to be ever on the alert for something new, novel, different. A salesman, a buyer, a producer are necessary. A traffic manager, etc.

In the beginning a person usually tries to assume all of the positions himself. This proves quite satisfactory in some cases where a person is trained from many angles and is very versatile but in many cases it is almost a hopeless proposition so outside help has to be called in to balance things.

Each department requires special training. Stop and say to yourself, "How well have I equipped myself to handle each department? Where am I strong, where am I weak? What can I carry on efficiently myself? Where will I have to call in outside help?"

One important item I use in classifying people is to find whether they are dependent on others for ideas or whether they can originate for themselves. Some worship the old things, others the new.

If you can create, you can greatly add to your show yourself but if you are not creative, you will have to get others to create for you.

After you have been classified then we want to sell you. Can you sell yourself, or will it require a salesman? Can you manage yourself or will it require a manager to stabilize and direct your movements?

Many performers depend on their own efforts to sell themselves; others are helpless on the selling end and must have aid in that direction. Suppose you need a salesman, which type is best?

Many angles have to be considered. Into what field are you going? In club, school, society, educational and religious work, a good all-around advance man is the best perhaps. A man or woman who can extoll your wares and interest others in your performance. Certain bookers or agencies in the larger cities specialize in selling club entertainers.

Now let us take it for granted that you are a good magician and we want to commercialize your ability. The first thing we look for is, "Into what type of magic do you belong? Are you best at manipulative, mechanical, chemical, mental or mathematical magic or the larger illusions?"

Let us say, for instance, that you are best at manipulative magic or sleight of hand with small objects. What objects are you best with? Which objects bring the biggest applause from the audience? Not necessarily what you might think will go best but what does the audience say? What are the live facts?

Suppose that your card work is best received. We classify you as a card manipulator. Let us continue. Is your work best appreciated with patter or in pantomime? Does your audience like your serious presentation or your comedy best? Is your own personality strong enough to carry you through or does a special setting strengthen your performance?

In your sleight-of-hand work which is best received, manipulative or sleight-of-hand that is mystifying, in which the audience is unconscious of any special moves to accomplish a certain illusive effect? There is a difference between a manipulative juggler and a manipulative magician. In the first case the audience gives credit for the performer concealing objects by dexterous moves, while in the latter case the audience is really and truly mystified and does not know how it is mystified. It notices no moves that are unnatural. Manipulative juggling gives rise to unnatural moves.

Continuing, where is your work appreciated the most, by men, women or children, close up or at a distance, in the entertainment, business, scientific, educational or religious circles? What class of society receives your work best?

In perfecting yourself you will run into mistakes, but profit by those mistakes. If you are not well received in one place do not worry. Learn your lesson and go to a place where you are appreciated. The fact that men have been ill-received in certain planes of life has lifted them out of those planes onto higher ones that they may never have discovered except through experience and the urge to keep moving into better environment.

CLUB ENTERTAINING

This is about the best way for a beginner to break into the magic business. All over the country are various clubs and organizations of which the social end is very prominent.

Club work offers a wide and varied field for the Magician and the student of Magic. One need not go into the theatre to make money with magic when there are unlimited opportunities to entertain in club organizations all over the country.

They can be reached by having a special advance man or salesman or by calling upon the heads of the organizations personally. Some performers use a mail campaign and send their folders to the various organizations within a certain radius, using a letter along the lines of the one below.

What are your entertainment requirements for this year? I am available now for special magical performances of odd and peculiar mysteries that furnish an unusual style of entertainment. Can arrange a program so that you can make money thru it or furnish you a special program at a given sum.

Magic is more popular than ever and no doubt you could use a good magician this present season. I should be pleased to talk things over with you or have you write me. May I hear from you at your earliest convenience?

But the personal touch is usually the best to get action and secure good profitable engagements. With a bit of judgment you can help organizations make money and charge a certain percentage for so doing. At certain times an organization can pay more than others.

Through filling one club engagement you can secure more. Some person in the audience - perhaps two or three - will know of a club that could use your services and will get in touch with you.

The newspaper write ups are also a boost for the magician. When the press puts out an article about the splendid performance at the L_____ Club, it means good publicity, it means that others clubs will want a similar or a better write up about their club program in the near future.

Read the letter received from Mr. C. S. A. of Benton Harbor, Michigan.

"....I have appeared several times locally; last week I performed before a large men's church club and only last night appeared before the local Exchange Club. The following effects were given in this order: Vanishing Wand, Cut and Restored Ribbon, Spanish Sliced Bananas, Burning Cigarette, Mystery of Traveling Numbers, Cards in the Orange, Passing Card in the Night, Popping Corn in the Hat, Swallowing Package of Needles, Mystery of Silks and Flame.

"Enclosed is newspaper clipping of last night's affair. I have received 'phone calls today for three more club dates.

"With kind regards to you and the school that puts 'purse' in personality, I am"

Club work, then, is undeniably the best way for a Magician to make money on the side provided he does not want to devote all his time to the profession. And the majority of students do not.

Aside from your regular business you can put on programs at clubs and earn extra salary. This additional work will give you all the benefits of a substantial financial increase.

To my way of thinking it is often more remunerative for magicians to do club work occasionally even tho they want to get into Big Time.

This recalls an instance that has happened many times in my own case. My magician friends were telling me about a certain lodge that would not pay over fifteen or twenty-five dollars for a magician. Knowing that I worked for higher prices, one of the boys thought he would play a joke by recommending me to the head of the Entertainment Committee. When the head of the committee called me on the 'phone, I made an appointment to have him come to my office and talk things over. I discovered that twenty-five dollars was about all the lodge could afford on the usual meeting nights for any kind of an entertainer. But I did discover that they had special nights for ladies and had a fund of Two Hundred Fifty Dollars set aside for each special occasion. So I sold them as an attraction for a special occasion, allowing them one hundred dollars for the orchestra and the one hundred fifty dollars for my services.

Such instances have happened time and time again.

And in club engagements you can use many types of magic programs, guiding yourself as to the type by trying to suit the different audiences. For club work you can perform any effects you like - usually with the exception of the illusions. It is well to arrange at least three or four complete programs so that when you have a return engagement you can come back with an entirely new and different performance.

As I explained to you in Lesson Thirty, carry different lines to suit different audiences.

Men like card tricks and sleight manipulations, tricks with coins, cigarettes, cigars, etc. Women usually are interested in effects with silks, and anything colorful. They like spiritualistic and emotional effects. Children like animal tricks, and tricks with candy. Keep everything suited to the occasion, and give enough variety to please a mixed audience.

The act lasts from fifteen minutes to an hour, depending upon conditions.

Club work, then, paves the way for greater things for the magician. He can by becoming known thru club engagements reach the topmost rung in the theatrical world in Magic.

THE EDUCATIONAL FIELD.

Under this branch come the schools and colleges. If a person is fairly well educated he will find schools a lucrative field. The chapel hour can be well employed as well as a special evening. Some performers combine an educational talk with their magic.

The athletic clubs and various organizations connected with school life are trying to raise money, and if you can help them with a show you can receive a certain percentage.

Schools are ever on the alert for special talent and a magician is always a big show attraction. You can make money for yourself by making money for the schools. As I explained in Lesson Thirty, present your plans for engagements in this fashion.

The school is to furnish the hall or auditorium and you will furnish the show. Admission is, of course, to be charged and you will work on a percentage basis. Because of your initial expense you will charge the first \$25 to \$50 taken in for yourself. Then you will split fifty-fifty on the rest of the proceeds. Or work on a percentage of two-thirds for yourself and one-third for the school. Percentages vary according to conditions 60-40 to 75-25. On some occasions a fifty-fifty percentage works out well.

In booking schools you should have a scrapbook with clippings, pictures, recommendations and things put up in a nice shape that will help sell you. Remember the school has not seen your show, so your publicity book must act as a silent salesman. If you are not a good salesman have an advance man do this for you and pay him a commission for doing so. Refer to Lesson Thirty.

CHAUTAUQUA AND LYCEUM

Here, too, is a good field for the magician. Certain types of persons seem specially fitted for this work, and while you may not care to get into this particular branch of Magic you want to know about it.

Usually there is only one magician on a circuit, but a bureau operates more than one circuit. For instance, Redpath Bureau has used three magicians at a time for years. The Lyceum Magazine, published by Roy L. Harvey and Co. at 431 S. Wabash Ave., gives a list of bureaus. It is the official magazine of the platform world. The chautauqua or lyceum show is about an hour and a quarter to an hour and a half in length. This is a full evening show.

If you do connect with a bureau they will pay you a salary of so much for the time you are working for them, plus transportation.

They will also get you up a folder by which you can be sold. The per cent of the folder expense you will have to share will depend on the policy of the bureau. If posters and window cards are required, these also are figured in.

This field does not have the opportunities that club work has for the average magician.

VARIOUS OTHER ENTERTAINMENT PLACES

There are many outlets for the magician. The summer and winter resorts offer opportunities. Churches have social centers, and hotels must cater to their clientele. Carnivals too offer almost unlimited possibilities.

One of my students tells me he entertained 2500 people on the grounds at a carnival with great success. The needle trick (Lesson 27) and the Tarbell Rope Miracle (Lesson 50) brought thunderous applause.

And a magician can become eminently successful in magic playing small towns. One of my students—again—in Canada made \$700 in the month between Thanksgiving and New Year. He booked ahead in fourteen or fifteen different towns and played every second day.

Fantastic and original posters sent on ahead caught the eye of the public and did much to draw the crowds. He had formerly worked on a ranch breaking bronchos for \$70 a month and by dint of advertising himself in the right way and putting on novel programs he jumped into the \$700 a month class.

THE VAUDEVILLE FIELD

For those who have vaudeville as their goal there are booking agents who will present your act to the vaudeville circuits. New York, of course, is the big booking center for America with Chicago second. In other countries you will find agents in the respective large cities from which vaudeville is controlled.

Find a good agent, put up your story to him. This should be done in person as a rule. Describe your act and ask for a showing. If he is interested he will arrange for a showing in a tryout house to give him a chance to see your act.

A tryout house may be just a junk house, but it answers the purpose to see what you have. If he likes the act, he will go to the higher-ups and try to book you. He charges you a certain commission for his work. It is usually five or ten per cent of the salary that he gets for your act. Sometimes one agent goes to another and adds another five per cent.

The first agent you go to may not handle you and you may have to go to others until you find the one that you want. Getting into vaudeville is not the easiest thing in the world, as there is strenuous competition to contend with and all sorts of angles to overcome.

But there is this one thing to remember. The beginner has just as much chance as the old-timer providing he can deliver the goods.

It used to be that a man's reputation would serve to book him, but that is no longer true except in rare instances. The old-timer must show his act and prove that it is good just as well as the newcomer into the field.

The first angles are usually to discourage a performer so as to reduce his personal opinion of his ability and his financial worth so he can be bought as cheaply as possible. It takes considerable bartering as a rule to establish a high salary.

Vaudeville buyers figure on the investment that has been made in your act, the cost of presentation, how many people you carry, and what it WILL PULL AT THE BOX OFFICE. Vaudeville is a dollar and cents proposition.

Houdini was successful in vaudeville, not because of what he did on the stage as much as the work he did off the stage to gain publicity that would pack the house he was playing and make himself a money maker for all concerned.

One of Houdini's first publicity stunts in Europe was when he appealed to the police of Dresden for permission to throw himself overboard handcuffed and free himself under water. He was refused permission, but managed to do his manacled dive despite the refusal. Toward the end of the month Houdini's run had broken all records for admission to the theatre and the manager was wiring appeals to the manager of the Winter Garten in Berlin, where Houdini

was scheduled to appear, to let him present Houdini for another month. The request was refused. Houdini went to Berlin. News of his dive in Dresden had spread like wildfire and the huge theatre in Berlin was packed to the doors.

Vaudeville is looking for another showman like Houdini. Never take vaudeville seriously until you can ask yourself and answer conscientiously, "What can I do that will create enough public interest to induce people to spend money to see me?"

But you must not think you are Houdini. He was one personality; you are another. Many persons see a successful personality and place themselves in that personality in imagination, but the audience cannot see the imagination, so it must go on what it sees and hears.

Before you give vaudeville a thought seriously, be sure that your act is right and test it out locally at the neighborhood houses. When you think you are set and ready, go to a larger city such as Chicago and book it around the smaller houses to knock off the rough edges, then on to New York where your FINAL SALARY IS SET. As conditions are now, you must go to NEW YORK to get good time. BUT DO NOT GO TO NEW YORK UNTIL YOU ARE SET AND HAVE AN ACT THAT IS AN ACT AND CAN BE SOLD AS A BOX OFFICE ATTRACTION.

Do not go to New York too soon. Your experience in smaller centers will give you valuable experience and tend to stabilize you. When ready for New York, get a good New York agent. Do not be afraid to make inquiries around as to conditions at the moment. You will receive lots of misinformation with the good information but weed out the facts. LISTEN MUCH and SAY LITTLE. Consider the source of your information and get it from the higher-ups who have clear vision rather than those who talk much and know little of true facts. Talk with people who have experience with vaudeville. But always consider that because one act may fail to land, another may be just the thing that is required.

Vaudeville conditions are constantly changing. When bookings are being made, there are certain open spots for certain types of acts, if your act fits all well and good. You have a chance. If the act does not fit, you must wait until there is a spot where you do fit.

Your act is CLASSIFIED as to whether you are an opener (first on the bill), a second act, middle act, fourth act or closing number. The intermediate acts vary according to length of program.

It is important in entering vaudeville to see that you are placed in the PROPER CLASSIFICATION as a classification is hard to change. That is why I want you to be sure your act is right before you hit New York. If you book in with a flash magic act, you are a flash magic actor. Later, if you wanted to go in as master of ceremonies, you would find it difficult to get away from flash magic classification. Sometimes you may go in and classify yourself as one thing but when the booker sees you, he forms another opinion and his

opinion is the one you are classified under. Many an actor thinking he is a John Barrymore discovers that he is classified as a Ben Turpin or eccentric comedian and wins success under the latter classification and, even though he might be making a whale of a salary, yet feel deep in his heart that sometime as a John Barrymore he will astound the world with his acting, and to those who will listen he will confide his woes of being misunderstood.

Important in vaudeville is the proper timing and speed of an act. If it is a fifteen minute act, make it fifteen minutes. Minutes are precious on the stage and it is a tendency that many times stage managers want acts cut which, of course, is a difficult thing to do and leave the proper impression. If it is a ten minute act, make it ten minutes.

Speed and grace is a vaudeville essential. Stimulation is essential to vaudeville and an audience likes to be thrilled. When an act closes, if it can leave an audience gasping with applause, so much the better. One seldom appreciates the speed and radiation of personality over the footlights in vaudeville until they have seen other acts work from the wings and are in touch with performers in other fields.

And yet a vaudeville act must have its moments of relaxation and a moment of slow motion to make the speedy parts stand out in contrast.

Cortini, the famous German magician, does a novelty magic act in eight minutes without apparent hurry or slowing down, with carefully timed motions that some magicians would do well to get through with in thirty minutes. He introduces slow motion with a tearing of a newspaper to contrast with a regularly speeded method.

In vaudeville particularly be daring and different. Do not imitate another style of act, unless of course you are classified as a mimic or character artist who imitates other people and gives them credit accordingly with their permission.

As a vaudeville performer you should belong to the National Vaudeville Association, whose main offices are in New York. Your act can be registered there as a protection and the Association helps to fight certain troubles that might arise.

Should you ever go into vaudeville I hope you will do so as a gentleman, a man of stability and a person who can be depended upon. A gentleman of consideration is welcome. Complainers and blah-blahers lose much. Talk little and think much.

One question that the average person thinking of vaudeville wants to know is, How much can I make? What shall I charge for my act? Well, that depends. There is no set price. What is it worth to a manager and what can he pay?

It requires a bit of experience to set a salary and it grows. Our high-priced headliners did not start out as high-priced headliners. They earned their way to the top and inspired confidence step by step.

There is one thing that most people either do not know or fail to remember. If one person employs another, that person must make him money, and in the proportion to the amount of money he can make for his employer the more he is worth.

Sophie Tucker, Elsie Janis, Dr. Rockwell, Van and Schenk, Will Rogers and others of similar prominence, are well paid because any one of their names on the bill means more people in the theatre and usually a packed house. They are indirect salesmen. There are many things to consider in framing an act. How much must you spend, how much excess baggage have you, how many salaries and railroad fares? What are the overheads? Never carry a nickel's worth of material that makes expense beyond that necessary to protect your act and keep it in tip top shape.

From your salary you must pay booker's fees, railroad fares, salaries, etc., as well as keep up the wear and tear of the act. All this must be taken into consideration.

Vaudeville employers will try to check up on you carefully and you might be amazed to see how close they figure your act. Employers realize that beyond salary there must be a percentage paid on investment.

However, when you can sell your personality without many props and pack the house, your own personality is worth more than a stage full of apparatus.

Certain circuits can pay more than others as the houses warrant the cost by the type of patronage and the number of people that can be seated. Some theatres can pay more for a single act than others can for a whole bill.

It will pay you, if interested in vaudeville, to study the vaudeville situation and note the reaction to various types of acts. You should read the "Billboard" and "Variety" magazines.

At present the tendency is modernism with novelty and flash. This is an age of extremes which gives a chance for the act in one or an act of a production nature. The in-between is apt to prove neutral.

The principles of magic remain the same, but the modes of presentation vary. I have trained you so carefully in principles so as to give you a background that will serve you for years to come.

In England the artist is coming to his own and a man is given credit for producing miracles with common objects.

Vaudeville undergoes changes in all its departments and no matter what branch an act may come under, it must contend with the changing conditions.

One must never forget that vaudeville is a high pressure type of performance and where high pressure comes there must be changes to counteract the stimulation on the audience.

If the magician will keep up to the minute on the changes and study conditions basically so as to keep an act up to present day requirements he has a good chance to succeed in vaudeville.

For those who are adapted for vaudeville, let them have it, but for those who are not, they should get into lucrative fields in which they do fit. It is peculiar that people are apt to pass up the big fundamentals of the magician and the many fields in life where magic is welcomed and the competition not so strenuous, to get into vaudeville. And if these persons would listen to the advice of those with experience and those who have analyzed the situation they would save themselves much grief.

Vaudeville is limited on the number of acts of a particular kind it can use, and an act has to await its turn for an opening.

If you feel that vaudeville is your forte, be sure to frame your act - get it in good working order out in the "sticks" before you submit it to a booking agent in New York.

Magic looms up with interesting things at which an audience will sit open-mouthed. Study the many interesting phases of magic - find your forte - develop it - master it -and fame and fortune are bound to be YOURS!

A handwritten signature in cursive script that reads "Harlan Tarbell". The signature is fluid and elegant, with a large, sweeping flourish at the end.

TARBELL SYSTEM, INCORPORATED, Chicago.

The paraphernalia described in this lesson can be obtained from the Tarbell System Incorporated.

LESSON 60

In this lesson we will discuss Publicity and Advertising.

(59-20)

ADVERTISING AND PUBLICITY

One of the big essentials of the show business is publicity that will excite the public and cause such interest as to make the public turn out and pay money to see the show. Many schemes have been devised to create interest. Associated with the show business has been high pressure advertising which stirs up quick action and gets instantaneous results.

The press agent has been a valuable man as he is in a large measure responsible for the success or failure of the performance. Public patronage is essential as that is where the box office pays. The press agent's duty is to sell and create a demand. You might have the finest show in the country but what good is it financially unless it is made known to the public in such a way as to create strong interest.

Beginners in the show business are too apt to neglect the press agent's end of the show and then wonder why they cannot make money. The biggest people in the show world have had press agents. While a performer cannot tell the public how good he is himself, as people shun those who pat themselves on the back, the press agent can extol the performer to the skies. Houdini carried a press agent, so do Thurston and many others.

A press agent must have a good sense of advertising and news value. He should be able to sense a good story at a glance. He should have newspaper experience or at least the newspaper instinct. He must know when to lay low and when to concentrate on a bombardment of heavy artillery. He should have the ability to make friends and to get full value for every dollar spent. Anyone can spend money, but it requires brains to spend money and make more money at the same time. It isn't what you spend for advertising but what you get out of it. A small amount of publicity rightly placed has more power than a large amount of the wrong kind of material.

It is the press agent's duty to analyze your show and see what is dominating it to catch the public eye. Sometimes it is necessary to change the program and put into it such material as will excite the public. Many times a seemingly commonplace effect can be dolled up into a good selling number. Many nationally known products today have been failures financially until some good advertising man got hold of them and found the selling slant around which he could write sales copy.

People like adventure, romance, mystery, daredevil stunts and things that gave thrill to their physical senses. In magic, one has a great opportunity for bringing in these very things. Clothe your performance with romance and special interest. Study the queer nations and tribes of the world and associate them perhaps with certain effects.

Think what an appeal to women if your assistant could be produced wearing a costume worn by George Washington's wife or presented to her by the President's wife. This, of course, is only an example.

The fact that people want to know what will happen in the future has made good business for so-called mind readers, etc. People like to have a rosy future pictured to them and therein lies the success of the fortune teller. Of course, most of the future is a blank and the human mind is not capable of telling future things except those based on what has happened before and will happen again unless something interferes from an unknown source. People can make guesses and give effects arising from present and past causes.

As far as MAGIC is concerned, it is still in its infancy. When one stops and thinks a moment as to what might be done with it, it makes one gasp. Conditions are changing so fast in the selling world that magic, like everything else, must keep pace with conditions.

Never forget that people pay for things they are interested in. And they will pay for the unusual. That is why I want you to rise above the mediocre and put yourself into the celebrity class.

To start in magic, you can begin gradually and be your own press agent for a while, then as conditions warrant, you can call in outside help. Your advance man can be a combination of a booking agent, manager and publicity man.

MAKING MAGIC PAY ITS WAY.

You can start in magic with very little money and earn your way step by step. As you progress you can add to your publicity in a way not possible at the beginning. As I have already said, the best way is to start with clubs, lodges and the various organizations that want entertainment for their members. You get a guaranteed sum for your services and require no posters, newspaper or handbill advertising to get the crowd. You sell your performance to the entertainment committee and then let them furnish the audience. Of course, the better you can sell yourself, the more money you will get for your services. You can sell yourself direct or hire an agent or manager to do so.

In selling yourself to clubs, schools, etc., it is well to have a scrap book containing any press notices you have saved from time to time and photos of yourself in action. This is not necessary, but it helps in selling as it gives something concrete for the buyer to visualize.

YOU CAN SELL FASTER THROUGH THE EYE THAN ANY OF THE OTHER SENSES. That is why a demonstration helps a buyer to visualize what he is buying. If you were selling a dog, you could describe the dog in words but if you would trot out the dog, one glance shows what he looks like.

In getting photographs of yourself, try to get something distinctive and unusual that will tell a story at a glance. It may cost you a bit more in the beginning to employ a good photographer, but you save money by it in the end. With high-lighting and shadow effects you can add mystery to your pictures.

I will give you samples of good photography that will aid you in getting yours done. There is human interest in each photo.

The usual size is 8 x 10 inches. Photos can be finished if desired in various colors or various tones of paper. I have just had some attractive photos made, printed in black on a gold toned paper. The yellowish tinge makes the picture pleasing to look at.

Where you are sold personally, an attractive sales book will work wonders in helping to book you. Have someone who is artistically inclined help you arrange the book. You can purchase a high type scrap book at one of the department or photographic supply stores. It should have a good attractive cover and bespeak of elegance.

Extra copies of the same photos that you have taken for the book can be used in many other ways in the preparation of folders, magazine articles, newspaper ads, etc.

THE FOLDER.

Many entertainers have a folder printed to sell themselves, especially if they sell by mail or want to leave literature for committees to look over. The folder is used in lyceum, chautauqua and the platform world. It is usually 8 x 11 inches and consists of four to six pages. This is usually designed by a competent artist and printed in two colors on enameled stock. I have designed many folders for the Redpath Bureau and in each I aim to put plenty of punch. If you are sold by an agent who sells other attractions, it is necessary to have a folder that compels attention. If a bureau sells you, it may want to prepare your folder or help you with it.

A number of years ago, while I was Art Editor of Photoplay Magazine, Paul Frederick Voelker, who was head of the Extension Department of the University of Wisconsin, wanted to sell me for special occasions, so I made up a special folder of my work for him. He noticed that when he placed his twelve attractions down before a buyer, my folder was usually picked up and looked at first. He asked his prospects why they picked up that particular folder first, and they said "Because it looks the most interesting". The result was that Mr. Voelker had me design a new folder for his own lectures. I solved his problem by making five beautiful paintings that would add a master atmosphere around the work. For one lecture on Joan of Arc, I had a photo made of the famous statue of Joan of Arc in the Art Institute.

I only mention this incident to show you the value of PRINTED SALESMANSHIP. The buyer does not know the performer and he must judge by the subject matter submitted to him. He gauges the performer accordingly.

I might liken good printing to a man's dress. If you call on a prospect nicely dressed, with well pressed clothes, good haircut, cleanly shaven and immaculate in appearance, wouldn't you have a better chance of selling yourself and performance for a good price than if you went in looking like a tramp.

People judge greatly by IMPRESSIONS and I cannot impress upon you too strongly the importance of creating a good appearance in anything that is associated with YOU and YOUR WORK.

Here is what Robert Ruxton, famous sales analyst, says in Printed Salesmanship.

"As the tailor tailors the good salesman, so the designer and the typographer tailor the good sales document, putting in the quality that breathes standing all along the visual line - a quality of skill, a quality of material, a quality in physical representation that inspires the confidence that men must have before they will deal with a firm with their minds at rest. It is the same confidence that we feel in dealing with a bank or other great establishment whose standing has been reflected to us from its building and interiors.

"If a badly dressed salesman loses business because of the way he is dressed, so will a badly dressed sales document. Thus a 'tramp' booklet or letterhead, purchased of some fancied saving in price, in reality becomes the most expensive form of advertising."

The beginner in magic can always start gradually and what he does should look neat and well designed. Go to someone who makes good work in printing a business, consult with an artist, an advertising friend, and see just what can be done step by step with the amount you have in hand. As you earn more and get better established you can increase your printing accordingly.

In Plates 1, 2, and 3 I am giving you examples of good folders that I designed for Thurston and Mardoni. Thurston's folder was printed in a deep rich brown on an India tint enameled stock. It was very rich in appearance. We were limited to one color so we wanted to get the highest type folder possible under moderate costs and existing conditions. Each page is interesting. Wouldn't you yourself like to see the show after seeing the folder? It is known as a four-page folder, each page being 8 x 11 inches.

In the Mardoni folder two colors were used, a brilliant orange and black. The flash of color had good selling power. To create mystery, shadows were made use of in the photography. Mardoni is a new comer into the professional field, yet he sells well. Note the sales captions: "What is Mardoni's Secret?" "The Human Enigma",

THE VANISHING HORSE AND RIDER IN MID-AIR



"Beauty," Thurston's beautiful snow-white Arabian horse, and his rider, while standing on a swinging platform on a brilliantly lighted stage, melts into thin air.

There are mysteries before which the universe stands aghast. It matters not what position in life you occupy, unless you have felt the thrills of amazement, have been spellbound by the weird supernatural demonstrations of Thurston, you have missed an experience of the rarest mental sensations.



THE instantaneous reduction of a lady of 20 pounds in 20 seconds. Volunteers welcome. A magical secret revealed nightly.



She Floats Across the Stage, Over the Orchestra, and Vanishes Like A Fading Cloud.



THE VANISHING DONKEY FINDS A WELCOME

MORE THAN 40 MILLION PEOPLE HAVE SEEN THURSTON

Oriental Miracles



A coterie of artists assembled from all parts of the world — beautiful girls who lend charm to this show of a thousand wonders, and Hindu fakirs who weave about the stage weird spells of the Orient.

"The Baffling Hindu Basket Trick" — This is one of the Feats of Oriental Magic that Travelers out of the Ancient East have been talking about for hundreds of years.

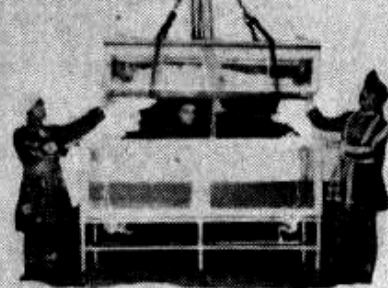


RED magic of the Rajputs — Hindu Fakir from the Sacred Temple of Fire at Bonares in 50 national Feats with Fire.



Hindu Fakirs in A Program of Oriental Mysteries.

Thurston has penetrated the veil of mystery and will present the world's most famous and greatest miracles, revealing secrets of many that have been guarded for a thousand years. He will show you the magic of the old and unchanging east and the marvels of the western world.



THE GREAT YOGI MIRACLE "BURIED ALIVE"

THURSTON is presenting this mystifying feat of the high caste Yogi from the Himalayas in the Himalaya Mountains, near Darjeeling, India, given in the western world the widest of all Oriental mysteries. You have read about this strange religious rite of living burial.

35 PEOPLE AND THREE CARLOADS OF BAGGAGE

Thurston Attracts Thousands Who Rarely Attend the Theatre



HOWARD THURSTON

The World Has Had But One Magician At A Time—

HERMANN, KELLER,

And Now—

THURSTON

21 Years America's Leading Magician.

THE MOST BELOVED ENTERTAINER IN AMERICA

Probably the Most Expensive Production on the Stage.

THE WONDER SHOW OF THE UNIVERSE

GUARANTEES MORE LAUGHS, THRILLS AND GENUINE ENTERTAINMENT THAN ANY SHOW ON BROADWAY



The Great East India Rope Trick — The Most Famous Feat in Magic—First Time in America.



MRS. HOWARD THURSTON

Every Man, Woman and Child Should See Thurston

You Will See Many Wonderful Things That You Will Never Forget As Long As You Live. BRING THE FAMILY

CENTRAL THEATRE

Broadway and 47th Street

BEGINNING APRIL 18th NIGHTLY, INC. SUNDAYS

Prices—\$1.00, \$1.50. Entire Lower Floor, \$2.00. Children to 16 Years, \$1.50 for Best Lower Floor Seats.

Prices—Wednesday Matinee, \$1.00 and \$1.50.

MATINEES WEDNESDAYS AND SATURDAYS. BRING THE FAMILY.

THURSTON
THE FAMOUS MAGICIAN
EAST INDIAN ROPE-TRICK
World's Most Famous Illusion
First Time—out-of-India
21 YEARS A NATIONAL INSTITUTION
NOTHING LIKE IT IN ALL THE WORLD



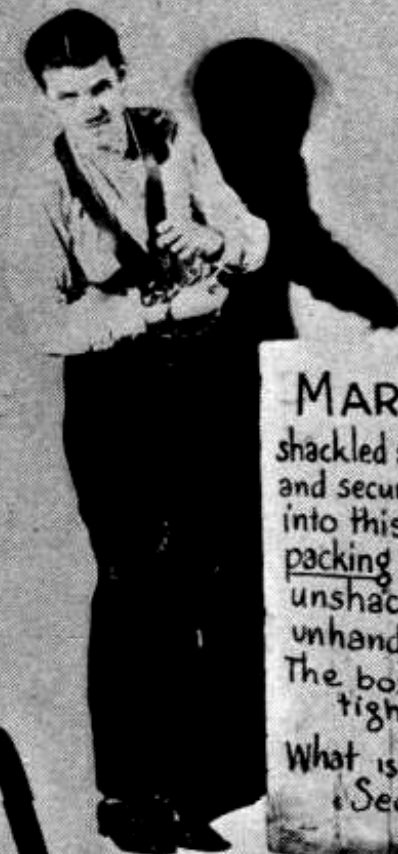
Mardoni shackled with the main captives of British/Army to escape from the "Redskins".



At Eureka, Cal., Mardoni is hoisted before leaving for the "Isle".



Mardoni diving from Lake Erie, securely handcuffed. Fifteen seconds later he was in the sea safe holding the handcuffs in one hand.



MARDONI
shackled and handcuffed
and securely nailed
into this ordinary
packing box emerges
unshackled and
unhandcuffed.
The box still
tightly nailed!
What is Mardoni's
Secret?



Mildred Mardoni

Mardoni

THE HUMAN ENIGMA
Renowned Escape Artist

"Renowned Escape Artist". Note how the photo of Madame Mardoni sells her crystal gazing work.

In these folders you note that each picture sells ONE idea and is not a conglomeration of many. Therein lies POWER.

Some performers have their pictures taken by a cheap photographer, the lighting is poor and the picture shows tables piled high with magical apparatus. The performer wears a misfit second-hand dress suit and carries a wand. The whole picture looks as if it might have been taken in the tintype period.

How does a performer hope to sell himself at a good fee with such a picture? DO NOT HAVE YOUR PHOTO MADE WITH A TABLE PILED HIGH WITH APPARATUS. It is not the conglomeration of apparatus that sells you, but WHAT YOU DO WITH IT. You must sell your PERSONALITY. You are a MAGICIAN and not a dealer in hardware or antique furnishings.

Do you want to belong to the Marshall Field or the ten-cent store class? Do you want to belong to the Rolls Royce model or the Skeedunk 1899 model?

It doesn't cost any more to print a good picture than a bad one as far as the printer is concerned, but it does add to the expense to print a "bum" picture, as far as selling results is concerned.

This is a new age, a speedy age, an age of flash and color. People want things at a glance. Give it to them.

THE SMALL FOLDER.

This is a type of folder designed to mail out in a regulation size envelope or to give out where a large size folder is not advisable. It is fine for booking clubs and many types of magical work. It costs less than a larger folder, but that does not mean it must be slighted. Every ounce of punch must be put into it that is possible so as to create a favorable impression. The photography and composition must be right. This type of folder is usually around 3 1/4 x 6 inches in size.

I have already discussed a folder of this type in Lesson 30. But now you can elaborate on it and get more of yourself into it.

The folder can be printed in one, two or three colors preferably on an enameled stock. Paper comes in white, ivory, India and a variety of colors.

YOUR LETTERHEAD.

If you adopt magic as a profession or semi-profession, a good attractive, well-designed letterhead is important. Something that will tell your story in a nice way and bespeak interest and dignity.

Here, again, let me quote Robert Ruxton from his article on selling principles in Printed Salesmanship Magazine.

"What is the credit value of appearances? Here is a case out of my own personal experience with an amusing twist which is typical. It occurred several years before national prohibition went into effect, but at a time when a number of states were reflecting the coming event by going 'Dry'.

"Wines, brandies, etc. could at that time be obtained by mail, from the wet states, but there was some peculiar law whereby a CASH order could command say \$7.50 worth of liquor, while an order dispatched on CREDIT could get double or \$15.00 worth.

"At the time I happened to have a very nicely embossed letterhead on a fine quality of paper that simply gave my name, the apartment, and the city. I wrote ordering a consignment of liquor to be sent me. I was a perfect stranger to the firms I wrote to, having had no previous dealing with them whatsoever. Nevertheless the consignment ordered was duly shipped, with the bill, and I was able during the following week to give the fleet captains a treat of good liquor - a fact I didn't forget to rub in.

"The next step, of course, was for them to follow my example and order by mail. They ordered all right, but they didn't get their orders. The various liquor dealers approached wrote back asking them for the cash. The various captains came aboard in hot haste to find out 'How I got MY consignment'. It was fun not to tell them, and I didn't, but the explanation was that they were ordering on blank or 'bum' letter sheets, while I was ordering on a beautifully embossed quality paper that commanded confidence.

"I continued to order, thus all the way down to Florida getting my double consignment, on credit, against the 'half' consignment of those who paid cash - this with a constantly changing set of dealers, just to show the crowd it could be done.

"Out of the comedy came the emphasis of one thing to my mind at least - the commercial value of a good letterhead."

Letterheads can be set in type with necessary ornament, or an artist can design one, a cut or cuts can be made from the drawing, and printed on a good substantial bond paper. For something extra good Strathmore papers can be used. The paper can be white, or some color tone may be used to lend individuality. There are some excellent letter papers on the market as well as envelopes to match.

A good commercial size paper, 8 1/2 x 11 inches is very practical. Papers run in odd sizes as well. Some like an odd size so as to make their stationery a bit different. Personally, I like the regular commercial size for the ordinary purpose.

WRITING LETTERS.

If you can write a good legible hand, you can write letters by hand, but the custom in this day and age is to use the typewriter as it can cover up many discrepancies. It is well to study writing letters so as to have good form. Be sure that your words are spelled correctly and that your letter is well written. In some cases it is better to dictate to a public stenographer and have her get the letter into proper shape.

Sometimes another member of the family can tend to the letter writing. If you are catering to educated people, you must have a letter that bespeaks culture and good training.

In writing for dates, it is well to have what is known as follow-up letters to write after a period of ten days apart, if the first letter does not get attention.

Where a number are sent out alike, it is well to have them multigraphed. The personal letter is best, of course, but where it is impossible to send so many personal letters, the multigraph has to be resorted to. It, too, should be well done.

TYPES OF LETTERHEADS.

I could write a book on letterheads. It is a big subject.

However, for the time being, let me call your attention to Plate 4 in which I have given you five sample letterheads.

The first is set in type with a zinc cut from a pen and ink drawing. The upper border is stock material and printed in red. Balance of letterhead being printed in black. In place of "Versatile Entertainer", Saal could have said "Magician and Shadowgraphist". In this case he is selling himself as an entertainer and not limiting himself to any particular branch of entertainment.

The second is that of Theo Okito (Theo Bamberg). It is lithographed and bespeaks dignity. When you get a letter written on letter paper bearing such a dignified heading you cannot help but feel impressed that the performer must have a reputation.

The third has a comedy touch. Those of you who know Frank Ducrot will know that it fits him. He is bubbling over with comedy. This picture was made by a high grade artist. The cartoon makes you smile with Ducrot. The fact that he says "Boy" magician gives you another laugh. You feel as though you would like to meet the man and see him perform. You instinctively feel that you could not spend a dull moment while he is around.

The fourth is that of Max Malini. It is set in type. He has used a rather clever catch-line at the top,



ALFRED P. SAAL

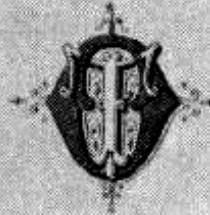
Versatile Entertainer

1735 FREEMAN STREET
MAIN 5157
FOREST 5150-W

Toledo, Ohio

THEO OKITO

*The Builder of a Chinese
House of Mystery.*



*Manager of
The Okito Family.
The greatest Chinese Magical
Wonder Act ever witnessed.*

FRANK DUCROT *The Boy Magician*



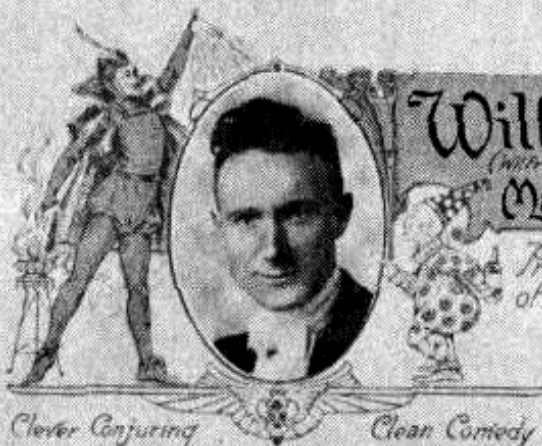
New York

"Honest To Goodness I only Cheat A Little."

MAX MALINI

The MAGICIAN

DIRECTION—EDWARD MCGUIRE



Wilfrid^{the} Wizard *(Wilfrid Rutherford)* Magical Entertainer

*Presenting a Mirthful Programme
of Mystical Conceptions for*

Club Lodge Church and Private Performances

510 Lyric Building
Phone Randolph 5540 Richmond, Va.

Clever Conjuring

Clean Comedy

Plate 4.

(60-11)

"Honest to Goodness I Only Cheat A Little". Here, again, the ice is broken without destroying dignity.

Let me say here that when a magician comes out with a clever slogan or catch-line, do not copy it. It belongs to the magician and is indicative of his work. People associate it with that particular magician. You can, however get another catch-line that will fit your style of work.

The fifth letterhead is a still different type. It is printed in black and buff. It is made from a drawing with a half tone photo insert.

In Plate 5 we have a number of other letterheads, also the type of envelope used by Okito. The embossed seal that he uses and pastes on his correspondence and literature adds a neat touch. The seal is printed in red on white paper and gives just the proper artistic appearance.

In Betty Jane Kolar's letterhead a few facts of interest about her are given.

Note how Sid Lorraine suggests magic with a handful of cards.

John Mulholland has a striking letterhead. It is printed in two colors, green and black on white paper. The rabbit in the hat tells the story. Mulholland's work is of the highest class and brings him before universities and highly educated people. For this reason he must be unusually careful in the selection of a neat letterhead suggestive of his work.

Chris Charlton's letterhead is printed in a deep blue on a parchment paper. It is an embossed heading and shows class. The coat of arms at the top adds distinction.

YOUR BUSINESS CARD.

In Lesson 30, I gave you an example of an inexpensive business card. I have been some excellent looking cards made from the example I gave, by those who followed the instructions carefully, and had type and arrangement duplicated, and at the same time I have seen some very weak cards by those who followed the wording but did not follow the style of type or arrangement and who employed a cheap printer.

An interesting style of card can be made by using a playing card for the background and printing on top of card. You can buy cards all alike from the various magical dealers. A deck with cards all alike is known as a "forcing" deck and was originally designed to force a card from by those not trained to force a card from a regulation deck. A playing card company could also supply proper cards, or at least cards with regular back and blank on one side on which you could have your printer print from a zinc cut you could have engraver make for you from a regular playing card.

From 02119
Maskelyne's Theatre, London

Gysel

SUPERMAN
OR
TRICKSTER
Which?
?

BOOKS

Joe J. Kolar, Presents

Betty Jane Kolar

World's Youngest Magician

10

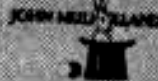
AN ENTERTAINMENT THAT IS DECIDEDLY DIFFERENT

LORRAINE

The Entertaining Magician



54 SHAW ST
TORONTO
Telephone
KAY 9295



107 WEST 115 STREET NEW YORK

APR 18 8, 1949



HAS HAD THE HONOR OF APPEARING BY COMMAND BEFORE THE
KING, QUEEN, KING GEORGE AND QUEEN MARY, AND
FROM TIMES SQUARE AND LATE JARRETT
AND EDWARDS ST

CHRIS CHARLTON

EUROPE'S ILLUSIONIST

1, Woodstock Gardens,
London, W. 8, U.K.

Sept. 1948 1949

Dr. Tarbell,
Chicago.

Dear Dr. Tarbell,

Please accept my acknowledgments on your course of Magic, at least up to the eleven lessons so far received. I have been a student of Magic all my life and a professional for over twenty years, and believe me I did not think it possible to learn Magic so easily, would that I could have had a course like this at the beginning of my career.

Although I have been earning my living from Magic for twenty years, I do



A Few Facts of Interest

BETTY JANE is the youngest of artists to ever have appeared upon America's stage and the only one who has been so honored who is also a child.

Betty Jane's debut performance was so successful that she has been photographed for the news news reels, and she has appeared in thousands of news items, and she has been the subject of articles and articles and articles in newspapers and magazines.

Betty Jane has the distinction of having received the highest honor for her young artist, the Gold Medal of the American Society of Magicians.

Betty Jane has been named "Sweetheart of the Year" by the American Society of Magicians, and she has been named "Sweetheart of the Year" by the American Society of Magicians, and she has been named "Sweetheart of the Year" by the American Society of Magicians.

The American Society of Magicians has named Betty Jane "Sweetheart of the Year" and she has been named "Sweetheart of the Year" by the American Society of Magicians.

At the age of 11, Betty Jane has been named "Sweetheart of the Year" by the American Society of Magicians, and she has been named "Sweetheart of the Year" by the American Society of Magicians.

When she was 11, Betty Jane has been named "Sweetheart of the Year" by the American Society of Magicians, and she has been named "Sweetheart of the Year" by the American Society of Magicians.

Betty Jane has been named "Sweetheart of the Year" by the American Society of Magicians, and she has been named "Sweetheart of the Year" by the American Society of Magicians.

These are some of the facts of interest about Betty Jane, and she has been named "Sweetheart of the Year" by the American Society of Magicians.

These are some of the facts of interest about Betty Jane, and she has been named "Sweetheart of the Year" by the American Society of Magicians.

not claim to know it all, and I am certain
that I shall get many useful things from your
course and probably a few items to add to
my show.

The People's Sunday newspaper
announced last week that David Bevan would
return to the stage this winter, no-one hopes
this is true more than myself, for I have
always been a great admirer of his, and it
would give a boost to most of us here, badly
needed at the moment, but up to the time of
writing I have heard no confirmation of the
report.

At the moment I am playing
three shows a day at the London Alhambra,
and in my opinion music was never received
better by the public than it is now.

With Very Best Wishes,

I am,

Yours Sincerely,

Chi. Charlton

Plate 5.

(60-13)

A RIGHT MERRY PROGRAM

\$ MILES AND LAUGHTER

GOOD ANY TIME

AFTERNOON OR EVENING **1927**

HAPPY HARRY HAYDEN
ENTERTAINER

PRICE
TAX
TOTAL

MUSIC

MAGIC

MIRTH

SMILES
LAUGHTER
HAPPINESS

BOOK HIM THRU
ANY FIRST-CLASS
ENTERTAINMENT
BUREAU

HAPPY
EVENING

RIGHT

A

An artist could also design an attractive card for you.

The card should have your name and address and a punchy sales line descriptive of your work. At least the card should tell what business you are in. By having a distinctive card different from the usual run, you create a desire in people to want to save it and show it to others.

Happy Harry Hayden has an interesting card, designed like a theatre ticket.

WINDOW CARDS.

Where your type of entertainment is given to raise money for organizations and the crowd must be drawn in from the outside by advertising, the window card plays a prominent part. Local merchants are, as a rule, glad to co-operate with local organizations by displaying cards in their windows. If the cards are attractive, they make good window dressing. They also save the expense of bill posting. To be effective, the window card must be attractive and catch the eye at a glance and quickly tell the story.

Because of the cost of a distinctive window card, I usually advise the beginner in magic to first make money in magic with clubs, etc., then when enough money has been made to warrant outside advertising campaigns, go to a good printer and have a card made up on the order of one in Lesson 30. When this has answered its purpose, have an advertising artist design a card with a wallop. From the drawing, a cut can be made for each color and taken to the printers. Window cards are usually printed on cardboard stock substantial enough to stand up in the window. In place of cards sometimes the design is printed on paper and held in place in window by small stickers.

Window cards can be attractively printed in one, two or three colors. The more colors used, the more the expense. However, color has selling power and should be used accordingly. The size is usually 11 x 14 inches or 11 x 17 inches or 14 x 22 inches. In the smaller towns it is almost impossible to have good window cards printed by local printer as he is not equipped for the work. Owing to the little demand for show printing, he does not have the facilities.

While on the subject of window cards, let me tell you about an effective window display that attracts attention. It is in the form of printing or design on a piece of colored paper, say, 3 x 6 or 8 inches. The paper can be readily attached to window by a bit of glue at corners. It is surprising what attractive notices can be made by these papers placed about town. Then there is the size of paper for windows about the size used by druggists for advertising a soda fountain drink. I recently saw a play advertised on the small sized paper idea with interesting effect.

For special local occasions a good sign painter or show card writer can fix you up with attractive display cards for windows.

An attractive display can be made by having some of your photos mounted on heavy mat board and attractively lettered.

In some stores which object to window cards you can often solve the question by having photos framed, and a photo placed in the window. On photo you can write "Yours Magically" and sign your name. Then on small card in corner, put where you are playing. This is an indirect system of advertising that can be made effective.

Some photographers make a specialty of making photos in large numbers for theatrical people and can supply quantity lots quite reasonable. Where a great number are necessary rotogravure is the more reasonable.

EXAMPLES OF WINDOW CARDS.

Plate 6 shows four window cards that I drew up for Reno, Laurant, Abbott and Elmore. The Reno and Laurant Cards are 11 x 16 inches, as that is standard size used by the Redpath Bureau. The Abbott and Elmore cards are 11 x 17 inches (They are cut three out of card stock 22 x 28 inches).

The Reno card is printed in four colors, red, yellow, blue and black. It is printed from zinc cuts with exception of picture of Reno which is made from half-tone process. This is an excellent style card for the magician as it tells a story at a glance.

The Laurant card is printed in three colors, vermilion red, blue and black. It could be printed in two colors, red and blue, the black being formed by overlapping the red and blue.

By printing with red and blue, some interesting three color effects can be obtained. This knowledge has saved some big printing bills for some of my large customers.

The card is made from zinc cuts, the face being Ben-Dayed.

The Abbott card is printed with black on a bright yellow stock. The bright stock with black printing makes a very attractive card. Printed from zinc cut with exception of the photo which is a half-tone.

The Elmore card is printed in two colors, red and black. It, too, is printed from zinc cuts. Note the opening of the eyes, the shadows and the devils to create mystery.

Plate 7 gives two examples of foreign type set window displays. Instead of being printed on card, they are printed on heavy enameled paper and held in window by a touch of glue or sticker on each corner. Rae's poster is printed with black on white paper, while Syko's is printed with a nice deep blue on white.

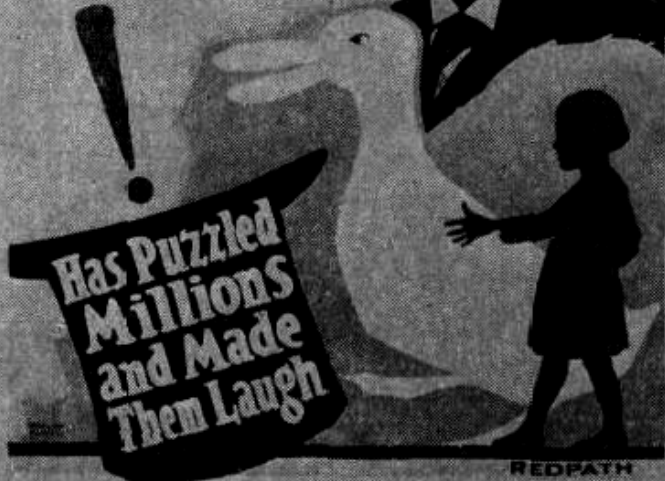
Rae's poster is adapted to England while Syko's was designed for South America.

3d Day
REDPATH CHAUTAUQUA

RENO

America's
Famous

MASTER MAGICIAN



REDPATH

at the
Big REDPATH Tent



Laurant

The MAN of MANY MYSTERIES
Magic Supreme

COMING

MYSTERIES of the ORIENT



ABBOTT

Australia's Greatest
Magician

A Never To Be
Forgotten Event

MASTER MAGIC



Frederic Elmore

and COMPANY

Nationally Popular Illusionists
in an Array of Startling Mysteries

Direction of E. V. LEWIS

Entertainment

FROM
St. James Theatre, W.
Winter Garden, Bournemouth
Devonshire Park, Eastbourne
Vaudeville Theatre, Brussels



AUTHOR OF
"Sub Rosa."
"Between Ourselves."
"Practical Patter."
"More Practical Patter."
"Wizardry with Watches."

BY
Mr. Oswald Rae
The Bewildering Humorist.

SUNTUOSO PALACIO DEL CINE
GRAND SPLENDID TEMPERLEY

AVENIDA MEERS N° 1086-08

U. T. 1174 LOMAS

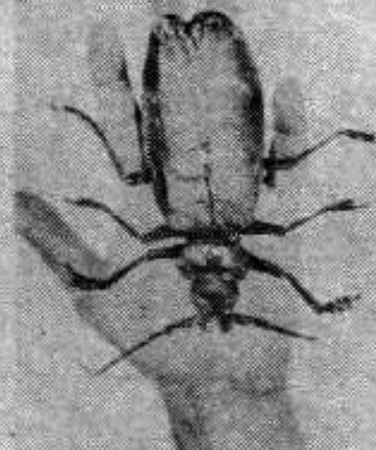
MIERCOLES 11 DE JULIO
A LAS 11 HORAS

DEBUT
DEL EXTRAORDINARIO ILUSIONISTA

SYKO

PRESENTACION DE SU ESCARABAJO
CON CEREBRO HUMANO.

Este coleótero gigante de
mostrará maravillosamente
cómo sorprendentes de tele-
patía entre el hombre y el
animal.



Un espectáculo verdaderamente
sensacional que Vd.
no debe dejar de ver.

EXPERIMENTOS CURIOSOS DE ESCAMOTEO
Y DE ILUSIONISMO
PRUEBAS INENPLICABLES QUE ALCANZAN LOS
LIMITES DE LO SOBRENATURAL



Who will present selections from his extensive Repertoire of
Fascinating Magical Effects, Sleight of Hand, Original Novelties, etc.

MR. RAE, has appeared
before

H.M. QUEEN OF BELGIUM on which occasion Her Majesty

sent for Him and **PERSONALLY COMPLIMENTED** Him on His Performance.

also **H.R.H. PRINCE OF WALES** etc.



DEBUT MIERCOLES 11 DE JULIO

GRAND SPLENDID TEMPERLEY

AVENIDA WEEKS Nos. 1000 - 1008

Plate 7.

(60-17)



MYSTERIOUS SMITH CO.

AMERICA'S GREATEST PRESENTATION



TRAUMLAND

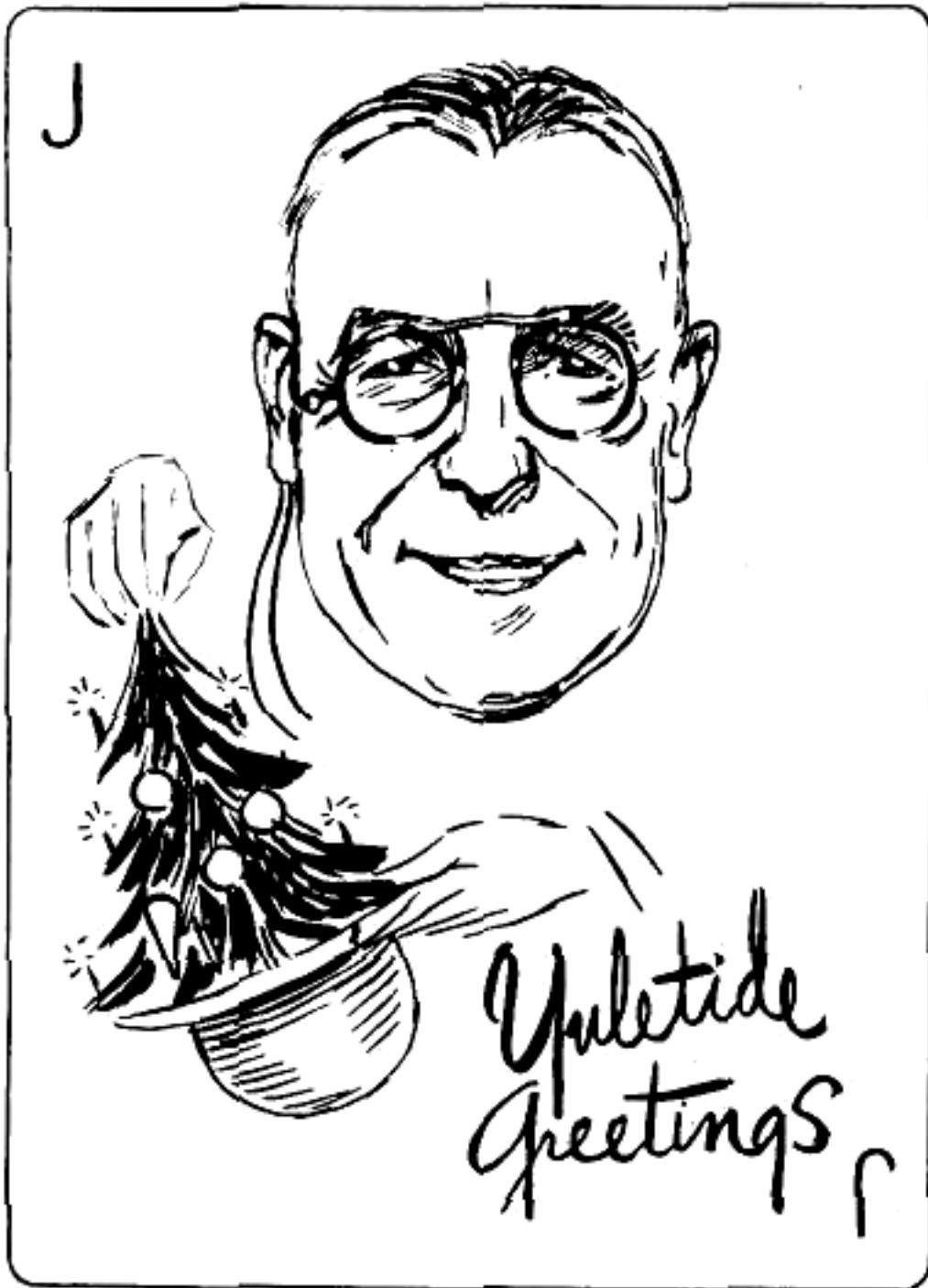
Transcendentale Mysterien
aus „1001 Nacht“

verf. u. abg. von

ERNEST THORN

Physicus

Hauptvertrieb: 73. II. R
Leipzig S. 3.



MAILING CARDS.

The mailing card is used to keep the magician in touch with his prospect or is given to the organization booking the magician to send out to those who might be interested in seeing the performance.

At the left is a card sent out by Gus Johnson of St. Louis at Christmas to his customers and friends so as to keep himself before them. People like to keep a card like this as it is different from the ordinary run of Christmas cards. The cartoon was printed on a blank playing card. The regular card back is on the other side.

You, too, can profit by having a neat card to send out at Christmas.

Plate 8 shows three mailing cards. The first is that of Mysterious Smith.

The card is in reality a photographic copy of a placard he had made with hand lettering and arrangement of photos. These photographic copies can be made in large numbers if desired. It is a very interesting card and suggests a mighty interesting spectacular performance. Smith has learned that the spectacular and apparent dangerous feats are big box office attractions.

The other two cards are from Germany, and used by Chevalier Ernest Thorn in his publicity. Thorn was a great believer in good publicity and high grade art work. His pictures and posters are truly becoming of a master.

WINDOW DISPLAYS.

Of good advertising value is to make arrangements with a prominent store in the town or city where you are to play, to give you a window display. This can be arranged in such a way as not only to benefit you, but also to give you the store publicity.

Perhaps you can exhibit odd

pieces of apparatus that would be of public interest, not to expose their working, but to have an interesting story around each.

In the lesson on the box for sawing a woman in half I suggested a window campaign.

There are also various mechanical devices suggestive of magic that could be used as the saw sawing a board by itself, the bottle that gives forth an endless stream of water, white paper changing to a dollar bill by running through two rollers, etc.

(60-19)

Tie-ups, too, can be used in store advertising. For instance, a wax figure used by store could be dressed up and given a hat to hold. From the hat could be coming a bunch of silk. Then about the window various objects that had been apparently taken from hat. A show card could say "How (Your name) takes all these objects out of a hat is magic, and the way we glean the world for things to give you service is also like magic."

A little ingenuity here will solve many problems for him who wants to be above the ordinary.

POSTERS.

I have already discussed small posters for window cards but now let us discuss the larger ones such as are known as half sheets, one sheets, etc. These are usually hung in windows or posted on billboards, etc. about the town, by bill posters who have control of the space.

A half sheet is 21 x 28 inches in size. A one sheet is 28 x 42 inches. This type of work is usually lithographed or made in wood cuts.

There is considerable expense attached to this kind of work and it is really only adapted to the performer going at magic in a big way. With a big full evening show, this form of advertising is advisable. Thurston, Dante, Nicola, Carter, Goldin, Blackstone and others must carry extensive colored lithographic advertising to pack the theatres. They are in competition with other theatres. For instance, Thurston reports doing \$29, 000 gross business during his two weeks' run in Cincinnati. That means that it requires extensive advertising to catch the eye of the public.

Should you ever put out an extensive full evening show, then you would want large posters in colors. But because of the expense you should have individual help in getting it ready. It is too big a subject to go into detail about here.

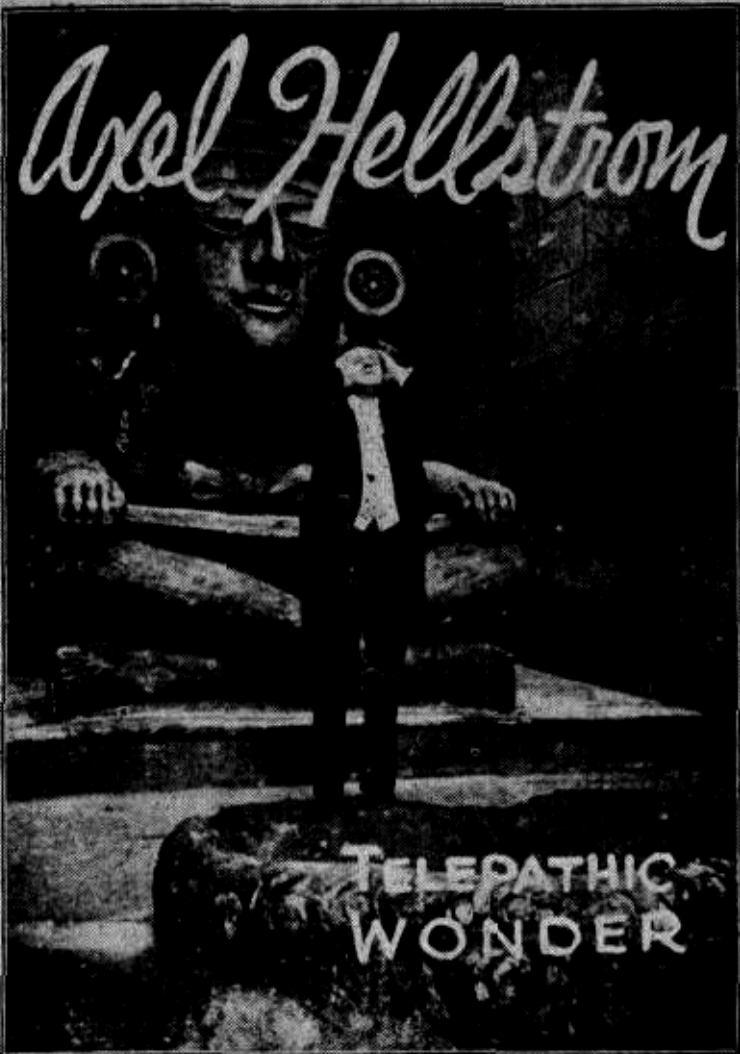
There is a type of non-pictorial half sheet that is printed from wood type and is put out quite reasonably by show printers. Sometimes this type of poster helps over an emergency. It also finds use in connection with the pictorial posters. Certain lithographic houses put out stock posters for magicians. While they treat magic in general, yet some magicians find them good business getters. The pages of Billboard magazine will give you ads of people doing this type of work.

Plate 9 shows three types of posters. The first is one of Carter's. It is very suggestive of a colossal magic show. The second is a German poster of Axel Hellstrom whose work is of a mental nature. The third is one of Dante's.

PHOTOGRAPHS.

I have told you already about the importance of good photography and that the best is the cheapest in selling your show. For this reason I will give you a few samples. The usual size is 8 x 10 inches, as they fit in lobby displays and are of a size that shows up nicely.

EN TOURAGE OF THE GLOBE



Europe's Great Magician!

DANTE

A DELUXE REVIEW OF MYSTERY
 An Innovation of Definess - A Triumph of Trickery



The big trick in having photographs made is to have a good photographer who has an instinct of showmanship and who can give you something distinctive that fits your personality and the moment people see the photo they associate it with you.

Plate 10.

1. Here is Cardini with hat and cane typical of Cardini's act. There is a foreign appearance in the pose that suggests an act from across the water.
2. Another pose of Cardini with his assistant (Mrs. Cardini). We still have the hat and cane and a wonderful likeness of Cardini. He looks as though he stepped out of a handbox suggestive of a big time act.
3. Dante, the world traveler. Note the effect of the tropical hat and the pose in profile, also light suit. You instinctively feel that Dante is a man of broad experience and has covered the world for points of interest.
4. Stowell. This photo suggests oriental mystery. Both poses are of himself. He is looking at himself in Chinese costume. Very typical of his show as it is both oriental and occidental.

Plate 11.

Hand-lettered photos, rephotographed for quantity.

1. This is my own photo by which I have been identified in my publicity campaigns. Note the mysterious effect caused by lighting from below. Light at the side gives a Mephistopheles touch.
2. Laurant. A photo lighted in modernistic German style. Modernism has been sweeping the country in advertising. Interesting effects can be obtained with high lights and shadows.
3. Percy Abbott. An interesting pose suggestive of good entertainment by a master entertainer.
4. Arthur Lloyd. Tells its own story.

Plate 12.

1. Laurant. Interesting, isn't it? Look at the expression on the boy's face, the artistic presentation of the doves, and the magic touch of the oriental assistant.
2. Doc Nixon. A type of photo used to show that the performer is a headliner. He carries his name in the electric sign.



Plate 10.

(60-23)

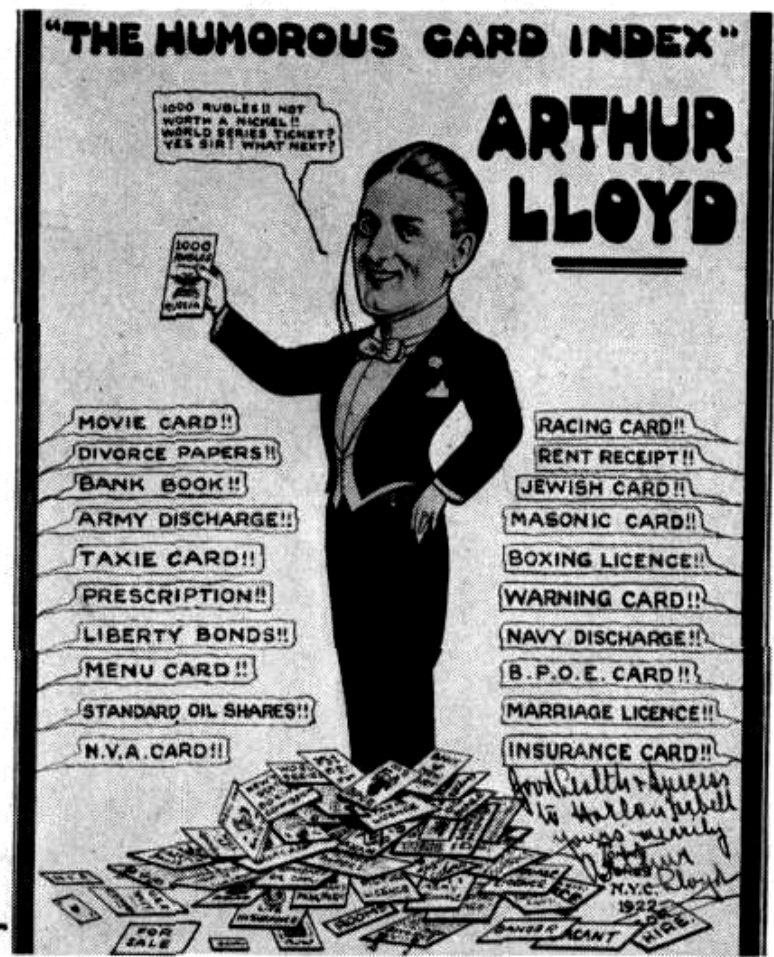
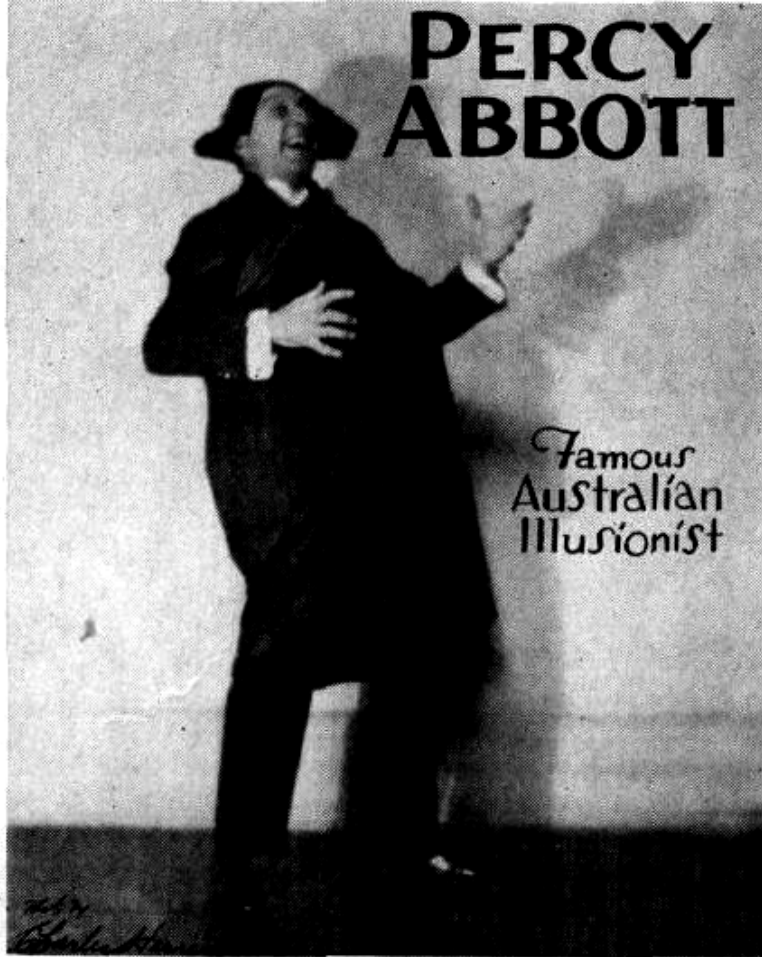
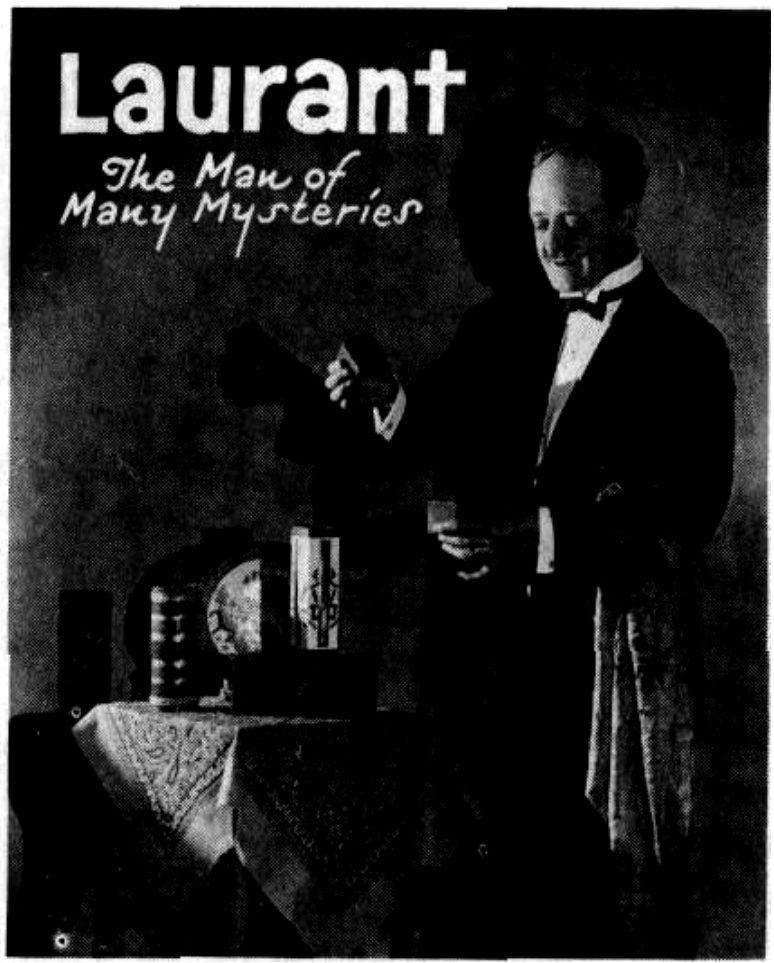
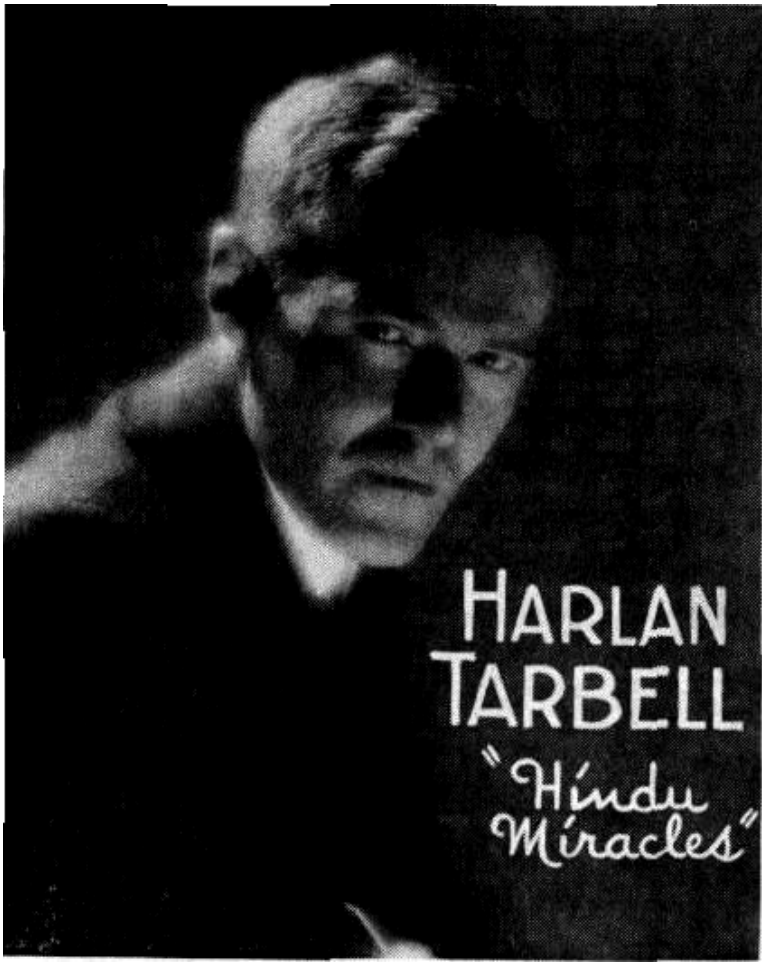


Plate 11.
 (60-24)

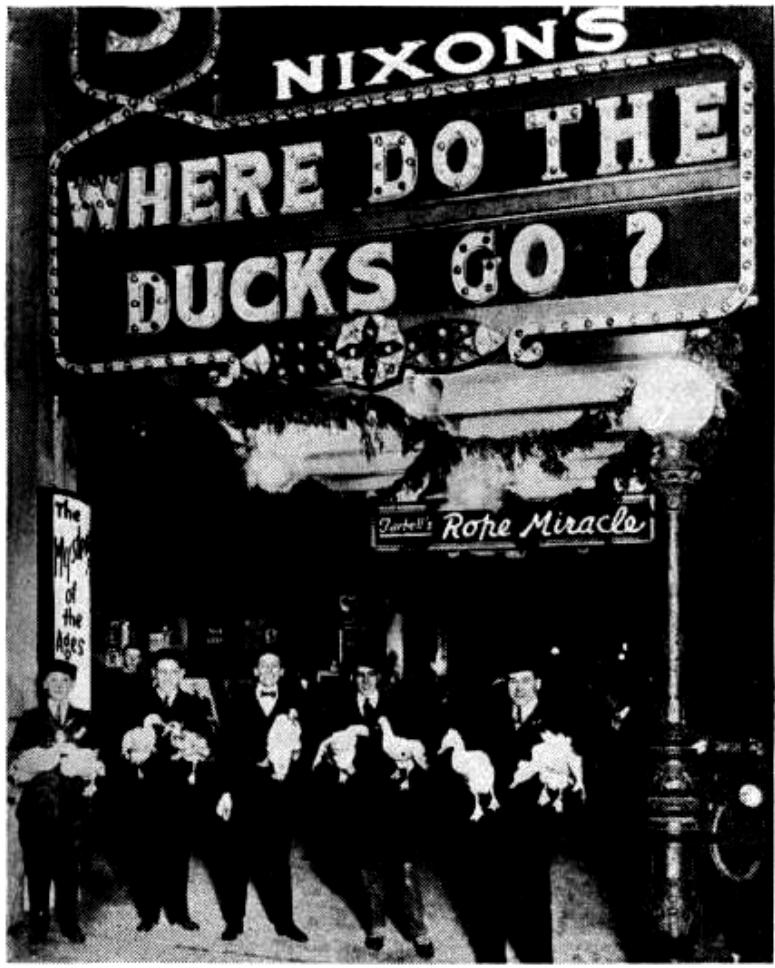


Plate 12.
(60-25)

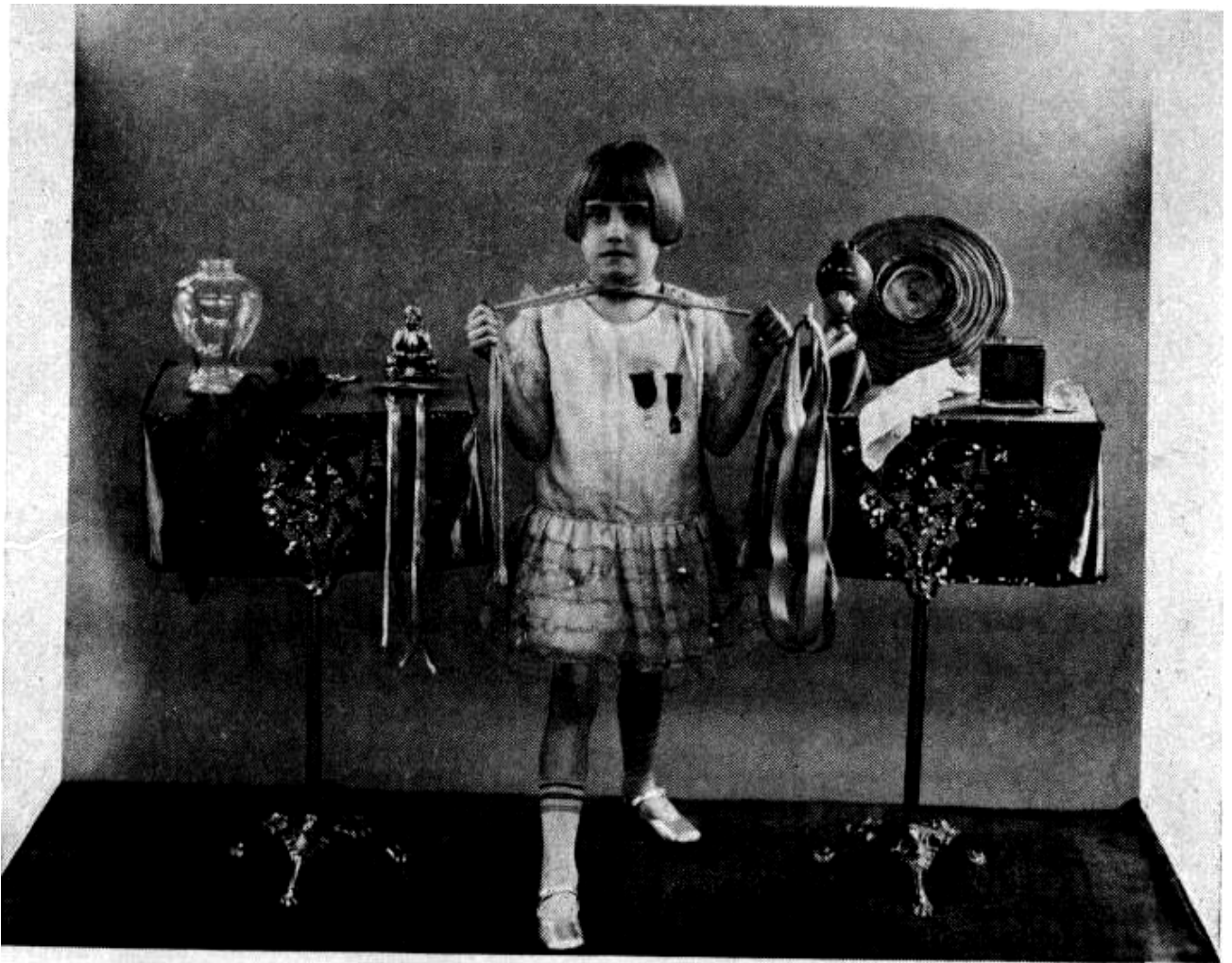


Plate 13.
(60-26)

3. Percy Abbott. The cigarette, shadow lighting and looking downward at side give the mystery touch to this fine photo.

4. Ollie Thomas. Hindu shadow figure and question mark adds mystery to a snappy pose of Thomas.

Plate 13.

1. This is a type of celebrity photo that carries a certain amount of interest and weight. I am photographed along with two famous motion picture stars, Dorothy Mackaill and Milton Sills during the making of the picture "The Barker." To be photographed in an intimate way with celebrities tends to carry you into celebrity class in the public eye.

2. Betty Jane Kolar. A child magician in action. The position and grip on rope suggests that Betty Jane knows her business. The two medals suggest prominence and celebrity class.

NEWSPAPER PUBLICITY.

Newspaper publicity and success run hand in hand. It is through the press that the public as a whole hears about unusual deeds and happenings. The press can do much to make or break a person.

Newspaper publicity is an interesting thing to study, for when properly handled it helps to keep your name before the public.

To begin with, it is well to know just what the fundamentals of a newspaper are. A newspaper is a money-making proposition, the same as any other business. It requires considerable money to run a paper, and money must come in for it to survive. Of course, some papers are run by rich men who put in money to meet deficits in order that papers can follow certain policies, or to aid in a political way.

The big money-maker of a newspaper is the advertising. The subscription price would hardly pay for the paper used. However, a large circulation is the thing to be desired, as the advertising rates advance accordingly.

SOMETHING TO BUILD CIRCULATION is what a newspaper wants. It welcomes anything legitimate to increase its readers. So it aims to print things that the greatest number of people want.

A type of newspaper that may appeal to one person may not appeal to another, for which reason we find various policies adapted to the differing publications.

However, THINGS BEARING NEWS INTEREST are eagerly sought for which fit in with the policy. The sensational and news of greatest interest dominates the front page.

If you want to break into print you must have something of news interest. Houdini had lots of newspaper publicity because he was on the lookout most of the time for stunts that would attract public attention. He stirred up excitement of some kind wherever he played, directly or indirectly. The main idea was to keep his name before the public.

The larger the city, the harder it is for a person to get newspaper space. The space is more valuable. To break into print in a small town newspaper is very easy as there is not so much high pressure competition. Chicago and New York are the two hardest points in America to control as a rule. They are the two largest cities. So much is happening there that it is hard to do something that will make a public impression. Of course, as your reputation increases and newspapers get to know you, the easier it is, and newspapers follow you, rather than you go to them.

But there must be a start. If you are giving a public show for which admission is charged, you must not expect to walk into a newspaper office and have them give you a writeup about your show, where it will be held, etc. Why should they? By giving you a free write-up it means loss of pay in the advertising department. Walk in and buy space in the newspaper and pay for it when it comes to the advertising field. However, if you spend money for ads and you have something of public interest, the editorial department may co-operate with you at least in an indirect way.

Personally I have found newspaper men very cooperative when the proposition was fair. I would lay my cards on the table before the editorial and advertising department and tell them what I wanted to accomplish and at the same time I was willing to do all I could to co-operate with the newspaper to interest the reading public.

Sometimes I would give a special performance to the newspaper men. Many times a newspaper would be fathering some charitable institution and I would play free of charge for that institution. The result would be a fine write-up telling of the performance and many times illustrated with photographs.

Perhaps the paper was putting on a special campaign that I could help them over with. Or I could put on a ballyhoo stunt free to the public under the auspices of the newspaper.

Nicola, Hardeen, etc. have gained newspaper space by doing the substitution trunk mystery on a platform built in front of the newspaper office. They helped the newspaper gain publicity.

Perhaps in your experience you have gained information, seen or collected things that would be fine for public interest. Sometimes the things you think the least interesting are the most. They may be apart from magic and yet act in co-operation.

Now there is John Mulholland of New York who doesn't seem to have much difficulty in breaking into print. John has always something interesting up his sleeve. "Whereas Tarbell is a magician who lectures, I am a lecturer who magics", he says, Mulholland travels quite a bit and is on the lookout for things of news interest. He has been in forty countries picking up information along the unbeaten path. He has collected odd pieces of magic and has one of the finest magical libraries in the country. He keeps up to date on magic and its kindred subjects, and is original in presentation.

Only recently he came into my studio after giving a number of lectures on magic illustrated with various effects. He had a roll of newspaper publicity under his arm.

In Plate 14 I have taken a bit of it, from Memphis, Omaha, and other papers. Note the length of the articles. The illustrated article was a front page one. Note the angles he used for news interest. He isn't afraid to make friends with the newspaper men, entertain them and make things interesting. He is a gentleman and knows when to leave at the proper moment while interest is sustained. He appreciates busy people's time and the value of a newspaper man's time.

Plate 15 shows a bit of my own newspaper publicity. McFadden of the Hollywood Mystics tipped the papers off that I was coming and the odd picture of cards coming from spectator's mouth jumped the article into the front page. The Examiner carries a double column illustrated article on their illustrated news page of a similar picture. Here is where I just took advantage of an odd magic effect at the moment for news interest.

The other article is from the Wilkes-Barre Record. I was doing a club show, so after the show I sat down and made a sketch of my impressions of the audience and gave it to a Record reporter. The result was three columns. The local character idea was good tie-up. For ten days thereafter, all the Wilkes-Barre papers gave me daily publicity.

Plate 16 is Mind Reading Publicity in the Chicago American secured by Axel Hellstrom. He entertained the detective bureau and created enough interest to warrant the article.

Plate 17 is a magazine article about my work in magic. The editor became interested in my work and wrote it up. I, of course, furnished the pictures from my collection of photos. Illustrations put life into an article.

It is a wise idea to give newspapers complimentary tickets to your show. Complimentary tickets rightly placed carry power.

NEWSPAPER ADS.

When you must resort to newspaper advertising in order to make the box office pay, you want to have ads that will have pulling power. It is wise to consult an advertising man and let him help you with your problem. No doubt you have a friend who is versed in advertising and who could

'FAKE STUFF' IS WAY MAGICIAN DUBS MEDIUMS

John Mulholland, Expert, Rapid Houdini Story

WILL SHOW HIS TRICKS

He'll Demonstrate How Public Is Fooled.

Don't be shocked that belief in witchcraft should have led to a murder at York, Pa. The great wonder is there isn't more violence because of it.

"You'll find people in every state who believe in witchcraft," says John Mulholland, lecturer and exposé of mediums and fortune tellers who claim supernatural powers. "And many of them are fervent and aggressive in their belief."

Mulholland is here to give two lectures at Goodwyn Institute. The first will be Wednesday night on "The Magic of the World."

"Superstition," he said in an interview, "isn't confined to any particular class of society. I know a famous scientist who throws a few grains of salt over his left shoulder whenever he spills any on the table. And I know an eminent author who always sits down and counts 10 whenever he forgets anything and has to return to his office for it."

Doesn't Believe Story
"Many of the things we consider proper and sensible began as superstitions," he continued. "For instance, we place our hands or our handkerchiefs over our mouths when we yawn. That started because years ago people believed a desire to yawn indicated the devil was trying to get in their mouths, and they started placing their hands over their mouths to keep him out."

Mulholland does not believe Harry Houdini, former magician, is communicating with Mrs. Houdini thru a medium, as she claims, according to dispatches from New York. "If a medium has read the code message Houdini left in his safety deposit box, then there has been a leak somewhere," he said. "In the first place, Houdini placed that message in the box as a publicity stunt, and I believe his confidants knew about it. In the second place, some one may have learned about it from Mrs. Houdini in one of her unguarded moments."

Fuzzies Reporters
In his hotel room Mulholland demonstrated various kinds of tricks for wide-eyed reporters. He also will give demonstrations at his lectures.

"We can't prove what is not known," he said. "If a medium tells me he talked with George Washington that night and George said so and so, I may not believe him. I may know that he is an habitual liar, and I may duplicate what he said happened. But that is as far as I can go."

"It takes the trained magician to expose the fakery. Not long ago there was a fellow who created quite a sensation as an Egyptian magician. Various attempts were made outside the profession to prove he was a fake, but without success. To us it was simple. We began by ascertaining first whether he was really an Egyptian, and found he couldn't speak a word of Egyptian."

An educated man is easier prey of a magician than an illiterate man, Mulholland said.

Persons React Same
"If I point my finger and tell a dog something, the dog will come and sniff my finger," he explained. "But a person will look in the direction I am pointing. We can get intelligent people to react as they should. We can get them to watching the birdie, so to speak, and then do our stuff."

"The average person always reacts the same to certain suggestions. That knowledge has been handed down from century to century. We don't know why. We just know he does."

Because of this, Mulholland explained, people obey the commands of the magician. He tells them to do certain things in such a way that he knows exactly what they will do.

Fortune tellers, he explained, are trained to look for clues that will open the way for them—initials on cigarette cases, emblems on hats, pictures in watches.

He Is Frank
Mulholland is 30. He says he has been a magician "since he was five." "Four years ago," he said, "I found my audiences were more interested in how I did my tricks than in the tricks themselves. So I started lecturing and throwing in the tricks for good measure. However, in all my career I never claimed supernatural power."

Thursday night he will lecture on "The Science of Soothsaying."

Ada Spends a Dollar



—Press-Schmitt Photo
John Mulholland, left, convinced Ada Gilkey, right, Press-Schmitt reporter, that fortune-tellers are fakes in an experiment to prove that they tell no actual facts unless they've learned them thru clever questioning of their subjects.

Mulholland, magician, lecturer and exposé of fortune-tellers, mediums and spiritualists, never had seen the reporter before Thursday. He "read" her palm. Later she went to a professional fortune-teller. The two fortunes tallied. And neither told her a thing that wasn't almost universally applicable, but he explained how "subjects" are led to believe that the occult one's stock generalities are in fact answers to their specific problems.

At Last! Dark Secrets of Palm Reading Exposed

Do you believe in "fortune tellers"? Do you marvel at their "occult powers"? John Mulholland, magician and foe of fakes, says all "fortune tellers" are merely fakes and first-class psychologists.
So Ada Gilkey of the Press-Schmitt staff had Mulholland "tell her fortune," then went to a professional "fortune teller," who closely paralleled Mulholland's "revelations"—and then went back to Mulholland, who explained each step and showed how easy it is to hoodwink the gullible.

By ADA GILKEY
Fortune-telling is the bunk.

It cost me a dollar and also an hour and a half to find out, but I'm convinced. John Mulholland, magician, who has just completed an engagement at Goodwyn Institute, helped me perform the experiment.

Mulholland, who delights in "showing up" fortune-tellers, told my fortune. It was rather a good fortune, too, although he protested he has no powers as a medium or "soothsayer." Then he sent me to an advertised fortune-teller to see if what she told me tallied with what he already had told me.

It did. "Madame," repeated practically everything Mulholland told me, except that she omitted the personality stuff and she said she "saw" two husbands, where he had "seen" but one.

"Love and Money"
Friday I had Mulholland compare the two "fortunes" and explain why he had told me certain things and why she had told me these same things.

"There are two reasons why a person goes to a fortune-teller or medium—love and money," Mulholland declared. "That makes the fortune-telling 'art' fairly simple."

Mulholland "read" my palm. Madame merely glanced at it. She ushered me into a dim bedroom. The light was so poor she couldn't have seen the lines in my palm had she tried. But she didn't. She scarcely glanced at it, after she had removed the dollar bill I had placed in it.

Almost simultaneously with the removal of the money, she told me I had the ability to make money but not keep it. I made a mental note that Madame at least has a sense of humor.

Not So Mysterious
"She didn't tell you how much money you could make," Mulholland pointed out. "Everybody can make money, but how much is a different matter. That you can't keep money is universally applicable, because few women can unless they're in the big executive class."

Madame adopted a clever questioning method and, had I not already been warned, I probably would have given her various "tips" to work on in unravelling my past and predicting my future.

"A man will never discuss stealing, although he will discuss infidelity as casually as the weather," Mulholland declared. "On the contrary, a woman will never discuss infidelity."

Madame said I would have good fortune. So did Mulholland. Madame said I'd get some money, but she didn't say how much. Safe again. She said, "I'd live to be old, and so did he." Just catering to people's desires, he pointed out.

DEBUNKER TERMS HOUDINI MESSAGE TO WIDOW FRAUD

Lecturer, Like Late Magician, Has Yet to Find Proof of Spirits.

By VINA LINDSAY.

A debunker of fortune tellers, religious seers and senders of spirit messages—including the alleged wraith of Harry Houdini—is John Mulholland of New York City, who addresses the Woman's City club today.

Mr. Mulholland, a former instructor at the Horace Mann school for boys and at Barnard college in New York, now is a magician and is devoting his time to lecturing on magic and to exposing the tricks of professional seers. He has studied magic in forty countries and has the largest private library dealing with magic in the United States. He was a friend of the late Houdini and, on Houdini's death, received the duplicate copies of Houdini's library of books, the original collection going to the congressional library at Washington.

The recent Houdini messages from the spirit world is a fraud, Mr. Mulholland believes.

Believes Ford Is Trickster.

"I believe Arthur Ford, the agriculturalist who delivered the message, is a conscious trickster," said Mr. Mulholland. "There is nothing convincing at all about the performance in anyone who knows anything of the tricks of mediums. It would be comparatively easy in the case of Houdini to perpetrate such a fraud."

During Mrs. Houdini's illness following the death of her husband, a large amount of the books and other properties of Houdini went out of the house. Much of this material went to friends as gifts. "These were footnotes on most of Houdini's books. Moreover, Houdini had persons on his payroll in all cities of the United States to report to him all developments in magic and to obtain information for him. All professional magicians operate in this way. A leakage through some of Houdini's many connections might well be expected."

The gullibility of the public makes fortune telling one of the big industries of the United States, according to Mr. Mulholland.

Seers Extract Millions.

"Millions of dollars are spent in the fortune telling industry yearly," he said. "Much of this is paid directly to seers and mediums and much more is paid in blackmail. Unscrupulous fortune tellers obtain information from their victims and then work in cooperation with blackmailers to make shake-downs."

Mr. Mulholland has told fortunes professionally for charity but has never practiced the art for his own profit.

"I would not even tell fortunes for charity now," he said. "My conscience would not permit me to do so. I have seen so much of the fraud of fortune telling and the harm it causes that I consider it a dangerous pursuit. The possibilities of the business are, he realized, however, when I say I made \$3,500 one night when I was working professionally."

At least one-fourth of the people of the United States believe in some form of magic or precognition, according to Mr. Mulholland.

Cites Witchcraft Trial.

"A belief in witchcraft and magic exists in every state in the union," he said, "and this belief plays considerable part in our national life. Of all forms of magic the religious magic is the worst and the most dangerous. The recent witchcraft trial in Pennsylvania, in which a man was tried for murder for killing a 'witch' is an example of the results of religious magic."

Mr. Mulholland has no more faith in the East Indian yoga, who wear turbans and achieve followings of society women in America than he has in the most obvious patent medicine fakirs at county fairs. He is an authority on East Indian magic, having been adopted in 1924 into the Indian family of Rakkhah, one of the oldest families of magicians in India. Reputable East Indian magicians regard their calling as an art or a science and do not seek to parade it under the guise of religion, he says.

Finds Them All Frauds.

An expert magician himself, Mr. Mulholland has made a study of magic from an academic viewpoint. He has investigated numerous spiritual mediums and, like Houdini, declares he has never yet found one who was not a fraud.

Kansas City, according to Mr. Mulholland, is one of the magic centers of the world. The magic publication here, "The Sphinx," circulates to all parts of the world, and Kansas City is a scene and a source for the exchange of tricks between magicians.

Last summer while in Roumania, Mr. Mulholland gave a performance in magic by command before the boy king Michael of Roumania.

Omaha 'Mecca for Magic'

John Mulholland Up to Many Tricks as He Praises Dave Abbott and Sniffs at Hindus.

"Omaha," said John Mulholland, absent mindedly tying a hard knot in his handkerchief, "is the mecca of the magicians of the world." He blew upon the knot and it disappeared.

"The reason," he continued, "is Dave Abbott—an originator of tricks of magic, who stands alone in his class. Twenty minutes after

I got off the train here, I went to see him."

Mulholland was in Omaha to speak last night at the Ad-Sell dinner, which was a father and son function. Members brought their sons, and 25 boys from Father Flanagan's home and the Masonic boys' home were special guests.

One of the world's outstanding magicians, Mulholland has spent years "chasing magic," and has knowledge of most of the tricks, he says, practiced in 40 countries in which he has studied. He began when he was 5 to "do tricks." Up to two years ago he was a professor for six years at the Horace Mann school in New York, a unit of Columbia university.

Spiritualism, or the tricks of so-called spiritualists, can be performed by any magician, said Mulholland. Same way with "fortune telling." You can learn it like you do your A, B, C's. "Mind-reading" is in the same class, he said. Psychology is something else again.

"Houdini, who, like many other tricksters or magicians, could do the stunts of a 'medium' or spiritualist, had not the slightest belief in spiritualism or the supernatural," said Mulholland.

Befuddled Reporter.

Superstition, he said, is to be found in all countries, among high and low. The "witchcraft murder case" in Pennsylvania is not surprising, it only demonstrates how superstition survives through the ages, he said.

"See you have a cigar paper," he said. "Mark your initial on it. Now tear it up." He took the pieces, and rolled them into a ball on his palm. He produced a sheet of writing paper. "Write on it a numeral, a letter and a simple geometric design, and fold the paper," he directed. He then put the "victim's" place the rolled-up cigar paper in his own vest pocket, so it couldn't be tampered with. When it was withdrawn, it was whole, and on it were the writer's initials, and the diagrams he had drawn on the large paper.

Performs for Kings.

"How about the Hindu mango-tree trick?" he was asked.

"Illusion and a process of substitution," he said. "Any magician can make a mango tree grow before your eyes. I don't have the trick with me. It comes in a package."

Not so long ago Mulholland performed before the sultan of Sulu, and before 7-year-old King Mihai I, of Roumania.

"The little king made me do something no magician ever does," he said. "He demanded that I repeat certain tricks several times. The queen of Greece, and the Princess Helena, the king's mother, were present. They seemed to enjoy the stunts."

SALES MAGIC IS CALLED MENACE

Lecturer Shows How It Could 'Ruin' Public

"Heaven help the people if salesmen ever learn as much psychology as the average magician knows!"

So says John Mulholland, exposé of persons who claim supernatural power.

Mulholland is here for a lecture series at Goodwyn Institute. Wednesday night he spoke on "Magic of the World." Thursday night his subject will be "The Science of Soothsaying."

"If salesmen did learn the psychological tricks of the magician, then our colleges would have to put in courses to teach us sales resistance," he declares. "I ran into one salesman a year or so ago who understood something of the art, and before I knew it he had sold me a \$200 car when I couldn't afford a real cheap one."

Trickery Is Seen

"There is an enormous amount of trickery in the ordinary phraseology. Teachers often defend the very thing they are trying to accomplish by the way they approach their students mentally."

"The first requisite of a good magician is that he be a master salesman. He often must sell his audience on the idea they are snps, and make them like it."

Many magicians of the past, Mulholland says, did questionable things. But he declares this is true of other arts, businesses and professions.

Has Great Library

"The butcher used to weigh his thumb with the best steak," he explains, "but he does it no longer. He quit it because he decided to clean house himself. It's the same way with magicians. Magicians could make thousands if they wanted to be dishonest card sharks. They like could make thousands telling fortunes."

Los Angeles Times



ES-BARRE RECORD, MONDAY, DECEMBER 8, 1924

An Entertainer's Impressions Of A Craftsman's Club Audience

NING, MAY 19, 1928.

CITY NEWS—EDI

ING FOR
TY POST

NOTICES MAILED IN CEMENT ROW

Beverly Protests Will Be
Heard 28th Inst.

Woman Calls Proposed Mill
"Crowning Blow"

Branch of Chamber Studies
Zoning Application

The Santa Monica Bay District Realty Board and Mrs. Lloyd Cochran of Brentwood Park are among the protestants against the proposed \$2,000,000 cement mill, rock crusher, brick, tile and other plants for which industrial zoning has been asked in the Beverly Boulevard residential-educational district between the site of the University of California at Los Angeles and the ocean.

City Clerk Dominguez yesterday mailed notices to property owners in this district of the hearing on the zoning application to be held at the City Hall at 2 p.m. on the 28th inst., before the City Council's City Planning Commission.

BOARD'S PROTEST

The district realty board protest was as follows:

The Santa Monica Bay District Realty Board in regular meeting today unanimously protest against the zoning of any property in the Santa Monica Mountains for industry of any kind or character and this specifically refers to the cement plant which has been proposed in this area.

MRS. COCHRAN'S PROTEST

Mrs. Cochran in her protest to the Council said:

The proposed cement plant sure is the crowning blow. The contempt and sympathy I feel for a faction which could entertain such a proposition to ruin the one scenic boulevard and residential district in Los Angeles I can't find words adequate to express.

I am a property owner in Brentwood and also own property downtown, so consider I have a legitimate "kick" coming. If this proposed plant receives your sanction it will be the greatest outrage yet perpetrated.

Mrs. Cochran lives at 229 North Clifford avenue, Brentwood Park.

NEW MEETING CALLED

The University branch of the Los Angeles Chamber of Commerce,

Now, Observe This One Closely



Master and His Pupil
Dr. Harlan Tarbell pulls a fast hand for Floyd G. Thayer.

CONDITION OF KEPPEL IMPROVED

County School Executive
Still in Danger, However,
Attendants Report

Mark Keppel, County Superintendent of Schools, who was stricken suddenly in his office Thursday, still was confined yesterday to his home at 1354 Bond street. Attendants reported his condition as improved, though not removed from danger.

Mr. Keppel had just returned to his office Thursday from Judge McLucas's court, where he had been

TOURIST HORDE ARRIVES IN CITY

Five Thousand Greeted Here
as Season's Vanguard

Guests Begin to Pour in from
East, North and South

Trains Loaded to Capacity
on All Rail Lines

Happy at being in Southern California, more than 5000 tourists, the vanguard of what is expected to be one of the greatest summer-tourist seasons in the history of Los Angeles, reached the city yesterday. An even larger number is expected to arrive today and the rush probably will continue tomorrow, when it will slacken slightly, only to reach its peak early in June, when eastern schools close for the summer vacation.

Summer tourist rates, which went into effect in the East last Tuesday, are responsible for the rush.

The Santa Fe Navajo, which reached Los Angeles at 7:30 a.m., was the first to bring summer visitors. It was followed five minutes later by the Southern Pacific Californian. The first Union Pacific train, the Continental Limited, reached the city at 8:30 a.m. All three trains carried extra cars, as did others which arrived during the day. Many trains were forced to run extra sections, in addition to putting on more cars than usual.

FROM EAST, NORTH AND SOUTH

The Southern Pacific estimates that 2000 tourists and homeseekers used its trains to reach Los Angeles during the day. Four trains arrived from Chicago and two from New Orleans and Texas points, in addition to those over the northern routes, which also brought more than their quota of visitors. All trains carried twelve to fourteen cars each, and one, the Apache, was forced to run in two sections.

All Union Pacific trains yesterday were run in two sections on account of the rush. Trains today, according to R. E. Robertson, assistant traffic manager, all will have two or three sections. Many of the tourists, he reports, stopped over at various points en route, but are expected to reach here today or tomorrow. About 1000 arrived yesterday, he estimates.

Santa Fe trains, with the exception of the California Limited, were able to run in one section

HE'S HERE FOR
IN LAND OF



Jimmy James
He arrived in Los Angeles yesterday's tourist accompanied by his mother, James.

WOMAN WHEN HI AUTO TR

Husband Collared
Being Informed
Fatal Injury

Mrs. Anna Stoltz

GEORGE
RAESLEY
PRESENTED
THE GREAT
BOX MYSTERY



TOM ROWLEY
WITH HIS SYMPHONY
ORCHESTRA WAS
ALL TO THE GOOD



BILL KEAR
GOT SO EXCITED
HIS HAIR (3)
STOOD ON END

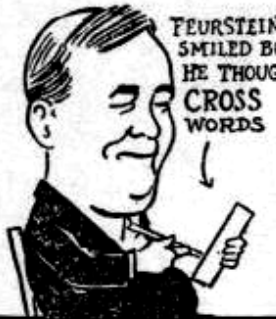


SAM
BLOCK
DIDN'T MISS
A THING

"POP" SMAWLEY
GOT FOOLED
BY A
CARD TRICK



FEURSTEIN
SMILED BUT
HE THOUGHT
CROSS
WORDS



LOOK WHAT
THIS FELLOW
HAS TO LUG
HOME
AT NIGHT



JOSH
B'GOSH

HARLAN
TARBELL

CRAFTSMEN HAVE BIG NIGHT

Club Members Enjoy Novel Entertainment Feature at Annual Nomination Meeting

Members of Craftsman's Club turned out in large numbers on Saturday evening to attend the annual nomination meeting of the club, and remained after the business session to enjoy an unusual entertainment program that had been arranged by the committee in charge.

of Harlan Tarbell, the scientific entertainer from Chicago.

The new orchestra, which shuns jazz and confines its attention entirely to worth while music of a classical nature, was warmly received and created a highly favorable impression. Mr. Rowley has built up a well balanced aggregation of serious instrumentalists who aim higher than popular music, and the enthusiastic applause which followed the selections indicated that the public is ready to show its appreciation of worth while music well played.

program, without any bewildering excess of words or actions, added to the mystifying effect of his experiments and created a deep impression. The fact that he presented new and original stunts, avoiding the familiar things that are the stock in trade of the average magician, was another factor in the interest and response that was accorded to him. He concluded his program with a series of quickly and cleverly drawn sketches, for which members of the club provided some of the subjects. This afternoon he will address a meeting of the clergy of this city at Young Men's Christian Association. To-morrow afternoon he will enter-

<p>conference ents" will at Pacific with them, the States and super- gets un-</p>	<p>investigating the applica- tion for the proposed industrial zon- ing, will meet next Tuesday evening to consider the action to be taken. The recommendations of the Uni- versity branch then will be forward- ed to the directors of the Los An- geles Chamber of Commerce.</p>	<p>witness in a school case, when he was overcome by what was said to be a heart attack, superinduced by an internal affliction. He was re- moved by ambulance to his home and placed under the care of Dr. C. B. Dickson. Mr. Kende has appointed in</p>	<p>his pupil. "Can you beat this one?" As he spoke he flashed a royal flush that he apparently had drawn from the high fog that at that moment was enveloping McFadden's City Hall. Among those who greeted Dr. Tar-</p>	<p>yesterday by the use of additional cars. The California Limited ran in three sections, two of which de- toured to the Grand Canyon en- route and are expected to reach the city today. The railroad estimates that close to 2000 tourists arrived over its lines yesterday, and expects</p>	<p>age, of 805 Venice Boul- fatally injured when run truck yesterday at Venic and Cherry street. She time later in the Georgi ceiving Hospital. Her George Stulkin, collapse</p>	<p>The meeting marked the first pub- lic appearance of the newly organized Wilkes-Barre Little Symphony or- chestra, under the leadership of Thompson H. Rowley, and also the first appearance in Wyoming Valley</p>	<p>deceptions and amusing charcoal sketches. He proved himself to be a genial entertainer who is not merely a clever trickster, but a keen student of psychology and a master of sleight- of-hand. The easy and clean cut manner in which he presented his</p>	<p>tain Woman's Club of West Pittston, and to-morrow evening he will ap- pear in St. Stephen's parish house under auspices of Men's Club of that church, with a popish lecture. Il- lustrated with crayon sketches. "Confessions of a Cartoonist," which will be open to the general public.</p>
---	--	---	--	--	--	--	--	--

Mindreading or What? It's a Mystery

JUST THINK ABOUT SOMETHING AND HE KNOWS WHAT IT IS



CONCENTRATING

Axel Hellstrom starting to demonstrate his power that is bewildering Chicago. He's concentrating while Sergt. O'Regan writes down a name on his desk at the detective bureau to test Axel's mind-reading ability.

"HERE IT IS"

"Here it is," Axel announces, as he picks out the rogue's gallery photo of the man whose name Sergt. O'Regan wrote. "How did he do it?" wonders the sergeant, at Axel's right, "he didn't see what I wrote." - How Axel does it is still a mystery.

Chicago Evening-American photos.

**MAGAZINE
FICTION-CONICS**

CHICAGO AMERICAN

CHICAGO, TUESDAY, MAY 22, 1928

**SECOND
NEWS SECTION**

MYSTERIOUS MIND READER SHAKES POLICE POISE

A slight, smiling little man, who might weigh all of 125 pounds dripping wet, walked into the detective bureau today and proceeded to leave a trail of knotted brows and meditative eyes in his wake as he darted briskly about the fifth and sixth floors.

He first called on Sergt. Charles O'Regan, introduced himself as Axel Hellstrom, and proceeded to do his stuff until the O'Regan eyebrows lost their skeptical quirk and drew together slowly as the performance became more mystifying.

"I am a mind reader," announced the visitor.

The sergeant tried valiantly to control a grin, and the visitor continued.

"Think of some one or something in this building and write it down," he said; "hold my wrist lightly and I will take you to it immediately."

EFFECT ELECTRICAL.

Mr. O'Regan pondered the matter, then announced that he was ready. He grasped his caller by the wrist. The effect was electrical.

Mr. Hellstrom leaped from his seat, darted through the door into the elevator, out of the elevator

through another door, a crowd of men and a long book-lined corridor. He entered the rogues' gallery, walked once around the room, which is lined with volumes containing the photographs of Chicago's underworld, selected a tome, opened it, and placed his finger upon the picture which Sergt. O'Regan had in mind.

"Humph," remarked the sergeant to a rapidly assembling audience, who had seen the remarkable demonstration. Several skeptics appeared with tests of their devising. Not once did the uncanny Hellstrom fail.

FINDS ONE IN 50,000.

At the mental direction of Sergt. Jim Stapleton he found one desired

thumbprint in a record containing 50,000. At the further mental guidance of Sergt. Mike Naughton he found a tieclasp hidden behind two boxes filled with paper scraps. Sergt. Roger Cahery admitted Hellstrom found the number he had in mind out of a list of forty printed on a sheet of paper.

However, when Sergt. O'Regan gave mental direction to land a leaf hook on the classic Stapleton case Mr. Hellstrom retired—courteously smilingly and swiftly. For Sergt. Stapleton tips the beam at 150, and Mr. Hellstrom might make 125 if he were dripping wet.

Safely Club Mail



Salesman's "Vanishing Cigar" Starts "Master Mind Behind Magic"

Tricks Seen as a Boy Inspire Dr. Harlan Tarbell, World Famous Teacher of 10,000 Students in Magic by Mail—Life Story Reads Like Romance

By ROY L. HARVEY

If the traveling salesman, who "did tricks" with coins and a vanishing cigar had never visited his home town, we should probably never have heard of Dr. Harlan Tarbell of Chicago, world famous teacher of magic by mail to 10,000 students.

Thanks to this same peregrinating purveyor of commodities, however, the name "Tarbell" is now a household word, wherever magazines are read and people are interested in entertainment. In fact, there is, in all probability, no better known correspondence teacher in the world than this young and brilliant doctor, psychologist, scientist, artist and writer.

Over a quarter of a million dollars is spent in advertising in all sorts of publications every year by the backers of the plan of spreading the gospel of magic by correspondence. The students are located in all corners of the civilized globe and consist largely of doctors, lawyers and other professional men, who desire to be able to entertain their friends at social and other gatherings.

Rub Elbows with "Greets"

Known as "the man behind magicians," Dr. Tarbell, smiling, cordial and clever, is about the busiest man in Chicago. His workshop in the Auditorium Tower is always full of magicians and the casual visitor will find himself rubbing elbows with men whose names are seen nightly



"MAGIC OF THE ORIENT"

Dr. Tarbell says these are special directions that Ching Ling Foo, the great Chinese conjurer, gave him. The paper may be torn time and time again, but refuses to remain torn.

in the electric lights over the larger theaters. They all visit Tarbell, from Thurston, to the veriest tyro, for they know that he is a never failing fount of ideas.

Harlan Tarbell became interested in



DR. HARLAN TARBELL, B.S., F.S.D., D.N.

portunity to show them at the children's parties in the neighborhood and later at the little entertainments given in his home town. It was when this traveling salesman, mentioned above, visited his town and Tarbell saw him doing tricks with coins and making a cigar disappear, that his ambition was really fired. He hunted the trail of the salesman and begged him to teach him how to do the tricks. It wasn't long before little Harlan was entertaining the men in the store where the salesman visited by offering them a cigar and then making it vanish before their eyes. Once Harlan was in charge of the Christmas program at his church. He got a former circus man to act as "Santa" and he himself produced the presents for the crowd out of a seemingly empty box.

When he was 14 we find our budding young magician organizing the "Metropolitan Amusement Company," with two other members and presenting shows at the Town Hall from a stage made of fence boards skillfully manipulated from the fences of sleeping farmers, and with the audience sitting on benches borrowed from the church.

"Thinks Up" His Tricks

"My funds were always limited," says Dr. Tarbell in referring to those early days, "and so I had to think up my own tricks as I didn't have the money to buy tricks from magicians." Because of this stern necessity the young artist devised many startlingly original feats and many of these ideas later became the basis of some of the most brilliant effects of magic

many of his effects breathe the mystery of the far east.

In addition to his magic skill Dr. Tarbell is one of the best known artists and illustrators in the middle west, doing commercial work for many of the largest concerns. He has made an exhaustive study of psychology and science in order to perfect his abilities. Before the war he was well known in this country and Europe as a society entertainer. During the big conflict Dr. Tarbell served in a balloon company overseas and was later art director of the American Red Cross in Paris.

The idea of teaching magic by correspondence was a natural outgrowth of a demand that sprang up. T. G. Cook of Chicago, one of the best known correspondence school men in the country, was frequently questioned by people who wanted to know why they couldn't be taught magic by mail. They were largely grownups, professional men, doctors and lawyers and others. They wanted to be able to do magic professionally for the entertainment of their friends. Diligent inquiry showed there was no such school in existence.

Houdini Boosts Him

The master magicians of the country had long dreamed of placing their art on a par with medicine and law and the other professions and they were, therefore,



"THE LIVING AND THE DEAD"

Sending the names of the dead from those of the living.

interested when Mr. Cook broached the idea of a school. They set out to find the best equipped teacher. Harry Houdini was approached and said: "Really there is only one man in America who can do the job—Dr. Harlan Tarbell. This is true



HIS MOST FAMOUS TRICK

The famous Tarbell Rope Mystery that has baffled magicians as well as laymen.

magicians, but because of his unusual ability to teach, backed up by his training as a doctor, scientist and psychologist.

Not yet thoroughly "sold," the sponsors of the idea next consulted Dr. A. M. Wilson of Kansas City, editor of The Sphinx, the official organ of the Society of Amer-

ican Magicians, and he, too, said Dr. Tarbell was the logical man. This was enough for the committee and so the doctor was called in and the project laid before him.

When plans had been matured it was recognized that most of the aspirants could not travel to a central school. Therefore the best thing possible was to build a course by mail so they could be taught at home. At the same time the course was so well illustrated and explained that the work became a magic textbook, good for years to come.

It is usually thought difficult to get backing for a new enterprise, but from the first the world's best magicians have been behind Dr. Tarbell and have praised his work, recognizing its value to their profession.

School on Two Floors

The Tarbell School occupies two floors at 1926 Stonyside Ave., Chicago, and a large staff is required to handle the business.

Although tremendously busy Dr. Tarbell has found time to act as first vice-president of the National Council of the Society of American Magicians, of which Howard Thurston is president.

Among other tricks he has originated is the famous Tarbell East Indian Rope Mystery, which Hamburg, great European illusionist, says is the finest trick in existence. Houdini once said it was the best trick originated in 100 years.

Because he has been extremely busy Dr. Tarbell of late years, especially, has had little time to entertain and so the public has been denied the opportunity of seeing this famous exponent of one of the most



"SEEING WITH THE FINGER TIPS"

With eyes securely bound with cotton, adhesive tape and black velvet, Dr. Tarbell distinguishes objects and reads letters or cards held at a distance from his finger tips.

difficult of all arts. However, after considerable negotiation the Poud Bureau of New York has succeeded in getting his name to a contract calling for him to offer a demonstrated lecture on magic for a limited engagement. Mr. Poud had searched long for someone, equipped not only to do magic, but to lecture on the subject and he feels he has succeeded beyond expectation in securing the man known as the "master mind" on the subject.

ANTRIM NEWS NOTES

Dietrich & Company have just completed a ten-month run for the Radcliffe Chautauques and they are now spending a short vacation in Philadelphia before beginning their Winter Lyceum Season for the Antrim Bureau.

The Córdova Concerters, consisting of Edward Clarke and Rachel Steinman Clarke with their excellent soprano, Miss Constance Neville-Johns and pianist, Mr. Frederic Searle, are now in the Antrim territory and are being received in a most enthusiastic manner in every town in which they appear.

The Community Players are also in Antrim territory and are presenting, this year, the very popular Broadway Play, "New Brooms," which committees report is the finest play this excellent dramatic company has yet presented during the past three years on the Antrim list.

Arthur MacMurray of Indianapolis spent several days in Philadelphia on his way to New York City, where he arranged

season and the Lyceum season following.

The Brace Trio are also travelling in the Antrim territory and have been received most graciously by their committees.

Elias Tainbuzina Serenaders began their tour for Antrim on October 26th after their big Chautauqua run for Radcliffe. Mr. Elias was obliged to cancel several weeks of his Radcliffe tour due to illness.

The Caveny Company, who recently closed for the United Bureau, are now on the Antrim territory and committees are enthusiastically reporting Mr. Caveny is putting over the best type of entertainment in his line.

FILL ENTERTAINMENT NEEDS

Louis Stockman, well-known teacher of dancing, and Arleigh Walta, dramatic artist, have organized the Stockman Theatrical Agency at 1343 North Illinois St., Indianapolis, Ind. and are meeting

Dancing Masters of America and also the Chicago Association of Dancing Masters and is an instructor at their conventions.

Mr. Walta served six years as art director of the Indianapolis Little Theatre; two seasons with the Stuart Walker Victory Theatre Company, and one year as stage director of the William School of Expression. He has also had experience in other theatrical companies.

These two energetic young men advertise that they are in a position to furnish programs for conventions, banquets, club meetings and stag parties. They are always interested in talent, also.

LOWELL PATTON, well known pianist, is the composer of the music for "Pearls," a late publication by the Manuscript Club, of Portland, Oregon. The art edition of the composition is enclosed in an attractive jacket bearing a large crayon sketch of Mr. Patton that is remarkably true to life. A number of his

magic when only a youngster. He developed a few tricks and soon found op-

as practiced today. He has always been especially interested in oriental magic and

because of his training not only in magic in creating new effects and assisting

for the royalty rights for several plays that he will present during the cha-

with success in their venture. Mr. Stockman is a member of the

other compositions are given the same unusual attention.

Plate 17.

(60-33)

help you analyze the situation and prepare ads for you with pulling power. The small amount you spend with an advertising man will be many times repaid in a very short while. He can help you weed out your feature numbers and those magical stunts which in your hands are apt to gain greatest public interest. He can also help to analyze space problems for you and what you can afford to spend to get certain results. Space varies in price in various newspapers. Where you might spend fifty cents per column inch in a small town paper, in a city paper like Chicago, you might spend \$14.00 per inch.

If possible, get a picture of yourself in the ad, or at least a picture of a trick or something to catch the eye. I have been a great believer in half tones and pictures to catch the eye. I would buy advertising space and then fill most of it with a picture of myself and an article written beneath it to look as near like news copy as possible. I have dominated pages with but a few inches of space accordingly.

Plate 18 is a type of publicity used by Thurston here in Chicago at the Erlanger Theatre. The article in upper right hand corner is a news article, but it illustrates my point on the half tone and article beneath to attract the reader's eye.

ADVERTISING SENSE.

In your advertising, use strong, concise straight-to-the point statements, but do not advertise the impossible. I have seen some mighty funny illogical advertising that did more harm than good. One must give the public some credit for being able to form honest opinions and classify things.

I remember one seedy-looking individual who gave me one of his folders which has a funny looking picture of himself with the headline "Greater Than the World's Best Magician." Anyone who saw the magician or the folder would know different, and would give him the Ha-ha.

Do not use such expressions as "The World's Greatest Magician", "The Greatest Magician in the Universe", "The Greatest Magician Who Ever Lived".

You are taking in a lot of territory and people will doubt you, unless you drop thousands of dollars of expensive advertising into the field, look like the proverbial prince and play in the largest theatre in town, backed by suitable newspaper publicity.

You can say "World-Famous Magician" if you are world-famous. Men like Thurston, Dante, Nicola, etc. are entitled to the title because they are world-famous.

There are plenty of good selling expressions that you can get plenty of punch with, and yet keep within reason.

ERLANGER MATINEE TODAY AT 2:30
TONIGHT AT 8:30

LIMITED CHICAGO ENGAGEMENT

EVERY NIGHT AT 8:30 **3** MATINEES—TODAY, WEDNESDAY AND SATURDAY



THE ONLY SHOW OF ITS KIND ON EARTH!
A NATIONAL INSTITUTION

The WONDER SHOW
OF THE
UNIVERSE

THURSTON
THE GREAT MAGICIAN
AND HIS DAUGHTER **JANE**
SINGING, DANCING COMEDIENNE

100-NEW MYSTERIES-100

See Thurston's Latest Illusion, "THE VANISHING WHIPPET CAR and TEN BEAUTIFUL GIRLS"

SEE "THE MILLION DOLLAR MYSTERY" THE LATEST EUROPEAN SENSATION
"IASIA"—SHE VANISHES AT THE DOME OF THE THEATER
"THE MAGIC BOX REVUE"—THE MYSTIC FOLLIES

NIGHTS, SUNDAY and SATURDAY MATS., 50c, \$1.00 and \$1.50.
POPULAR PRICED WEDNESDAY MATINEE, 50c, 75c and \$1.00.

HANKY-PANK.



THURSTON

He's due in the Erlanger this afternoon after a long absence from Chicago. Thurston has been foolin' 'em through many years; and there is still a public for the wiles of a good magician.

AMUSEMENTS.

ERLANGER FINAL WEEK

The **D'Oyly Carte**
OPERA COMPANY
IN GILBERT and SULLIVAN OPERAS
TONIGHT and MATINEE TODAY
"TRIAL BY JURY"
and

"The Pirates of Penzance"
THURS., FRI., SAT., "IOLANDE"
STARTING NEXT SUNDAY MATINEE
SEATS NOW ON SALE
SEE THE VANISHING WHIPPET CAR
AND 10 BEAUTIFUL GIRLS

THURSTON
The Famous Magician and His Daughter
JANE, Singing, Dancing Comedienne
Nights, Sat. and Sun. Mats., 50c-\$1.50
Wednesday Matinee, 50c and \$1.00

—The Spectacle of n.

Dolores Costello
—IN—
NOAH'S ARK
AND COMPANY OF 10,000
A WARNER VITAPHONE TALKING PICTURE
DROS.
Seats Now Selling

ERLANGER **3** WEEKS ONLY
MATS. SUN., WED. AND SAT.
SEE THE VANISHING WHIPPET CAR
AND 10 BEAUTIFUL GIRLS
THURSTON
The Famous Magician and His Daughter
JANE, Singing, Dancing Comedienne
Nights, Sat. and Sun. Mats., 50c-\$1.50
Wednesday Matinee, 50c and \$1.00

MAJESTIC LAST WEEK NOW

IT'S A WOW!

Nites, \$1-\$2.50. Wed. Mat., 75c to \$1.50.

ERLANGER **3** WEEKS ONLY
MATS. TOMORROW, SAT. AND SUN.
SEE THE VANISHING WHIPPET CAR AND 10
BEAUTIFUL GIRLS

THURSTON
The FAMOUS MAGICIAN
AND HIS DAUGHTER **JANE**,
SINGING, DANCING COMEDIENNE
Nights, Sat. and Sun. Mats., 50c-\$1.50
Wednesday Matinee, 50c and \$1.00

ORCHESTRA FRI. EVE & APR. 12
BALL 8:30
ROLAND CELEBRATED
NEGRO TENOR
PROGRAM OF REQUESTED FAVORITES
HAYES

The word MAGICIAN tells a big story, or Magician and Illusion, or such titles as:

Comedy Magician

The Man Mysterious

Society Magician

Specialist in Sleight-of-Hand

Misdirectionist

The Mystic Deceiver

The Man from Magicland

Eminent Conjuror

Oriental Magician

Oriental Mystifier

European Illusionist, etc.

You who are of foreign birth or over from the other side of the water can capitalize on your foreign distinction. Distance, as you know, lends enchantment.

* * * * *

And now, my dear student, we are drawing to the end of this course in magic. I have spent many hours and days in helping you to reach a place in magic that both you and I will be proud of. We have covered a lot of ground. I have endeavored to give you material that you will be proud of as long as you live. The course is three times the size I originally planned.

But I do not want you to stop here. I want this to be the foundation that will hold your ladder of success as you travel upward, - "A house built upon rock will stand."

My interest in you does not stop here. I want to hear from you and know how you are progressing.

Always hold magic dear to your heart. Strive to improve it. Be of service to your fellow magicians and do what you can to help them in their work. Co-operation means so much in life's building.

"The Sphinx" Magazine, published by A. M. Wilson, M.D., 1007 Main Street, Kansas City, Missouri, will help you to keep in active touch with the field. You should be a subscriber by all means. I look forward to the Sphinx every month with interest.

We have two magical societies in America, the Society of American Magicians and the International Brotherhood of Magicians. Abroad, we have interesting magical publications and societies. Students abroad should investigate them.

Hold tight to your copy of this course in magic. You will find it more valuable every time you reread it, and some day it may be worth its weight in gold to you. You will thank me many times later on for this advice.

This course represents and brings to you thousands upon thousands of dollars worth of knowledge. You cannot afford to take the chance of letting this accumulated value

slip from your hands. So guard your course closely and protect it well.

The future holds many wonderful possibilities for magic. In a way we have only touched the surface. But with the experience of the past and of the present, we can work wonders if we will in the fast-moving age. The world holds out its hand to men who are big and do big things. Success attracts success.

There is much ahead for both you and me in magic. I want to surround myself with the finest trained magical men with whom it is possible to surround myself. Working in co-operation and dealing with problems as they arise and progressing step by step, we can work wonders together.

We are really just entering into a grand new era of the show business, and if you will stand by the ship loyally and sincerely, you should reap a splendid reward.

Establish good credit, pay all your bills promptly, develop poise and ease of presentation, lend a helping hand to a brother magician, and keep your eyes open for the big things of life. Choose companions that will tend to lift you up. Be dependable.

And so we have come to the end of this course, but really just the beginning of things I want to prepare for you for the future. Life is constantly changing and we must be right on the job to be headliners and a jump ahead of the crowd.

With best wishes for your success,

A handwritten signature in cursive script that reads "Harlan Tarbell". The signature is fluid and elegant, with a large, sweeping flourish over the "T" in "Tarbell".

(60-37)